

KING TIGER

Sd.Kfz. 182

HENSCHEL TURRET

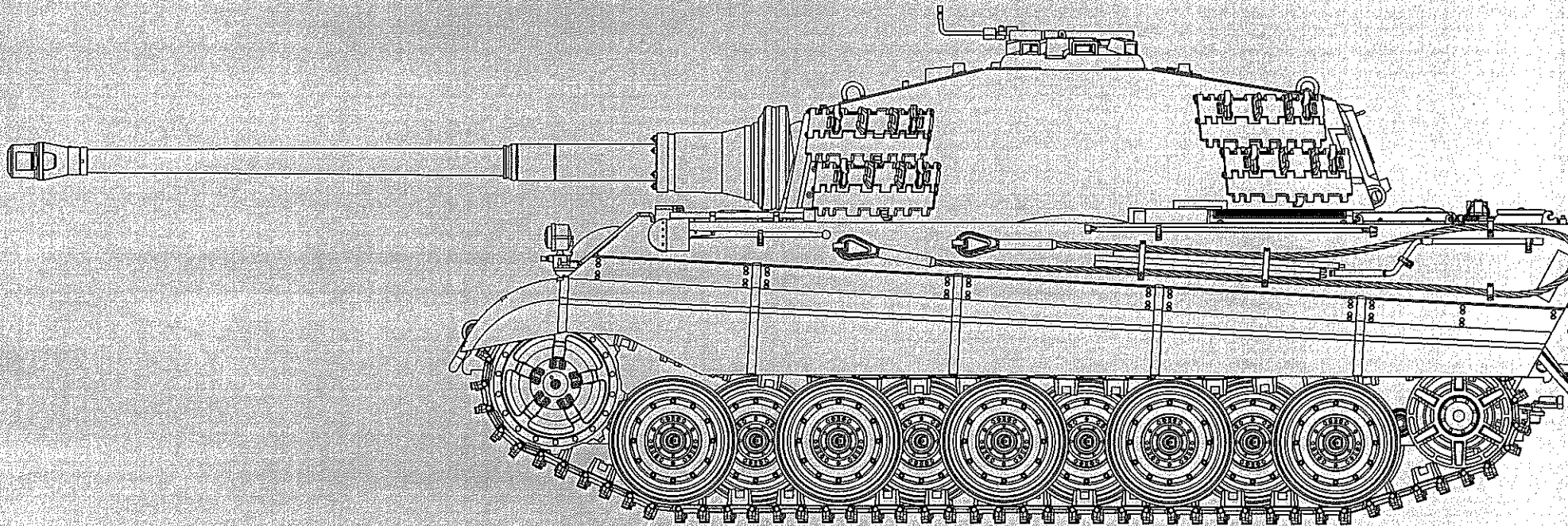

The German Tiger Ausf. B, or King Tiger was arguably the very best tank that was put onto the battlefield during WWII, as well as the most costly. With each unit requiring some 300,000 skilled man-hours to complete, the King Tiger went into production in December 1943 at the Henschel factory in Kassel. At the peak of production it took only 14 days to complete, and by the end of the war 492 examples were ultimately produced of the 1500 units ordered due to the intense Allied campaign.

With frontal armor reaching up to 150mm thick and side armor 80mm thick, this nearly 70-ton tank was built around the famous dual-purpose semi-automatic 88mm canon firing armor-piercing or high explosive rounds, the KwK 43 (L71) produced by Krupp, with the T.Z.F.9b/1 binocular gun sight (later followed by the monocular T.Z.F.9d) built into the cradle. This set-up allowed the tank to engage virtually any enemy tank before it could come within firing range. The Henschel production carried 86 rounds of internally stored ammunition for the main gun. Additional armament came in the form of 3 Rheinmetall Maschinengewehr 34's with 5800 rounds; one mounted in a kugelblende on the right bow position; one mounted coaxially with the main gun; one mounted externally to the commander's cupola.

This massive tank was mobilized by a OLVAR EG40 12 16B mechanical transmission with 8 forward and 4 reverse gears powered by a 690hp Maybach HL230 P30 gasoline engine, with a top speed of 25.8 mph (41.5 km/h). The crew consisted of 5: the tank commander, the loader, the gunner, the driver, and the radio operator. The only other variant of the King Tiger was the Hunting Tiger, or Jagdtiger. With the exception of the initial prototype, all King Tigers were coated with zimmerit from September 11, 1944.

The King Tiger dominated the battlefield in terms of capabilities, but often suffered from shortages of lubricants & fuels. These tanks proved themselves in battles ranging from Normandy, the Ardennes, Lake Balaton, and Berlin. Although it fell short of the expectations of the 'Wunderwaffe', the King Tigers were ineffective in stopping the overwhelming numbers of opponents they faced on the battlefield. Today there are a total of 11 King Tigers preserved around the world, with the rest having been long lost to the scrap yards.

This new King Tiger model kit represents the ultimate in dimensional accuracy for the first time through the unique feature of scale-thickness armor and a complete interior. For the first time in 1/35 scale we can appreciate the full experience of this infamous tank, from the driver & radio operator in the fighting compartment to the loader, gunner, and commander in the turret, as well as the engine compartment complete with Maybach engine. Every detail inside & out was painstakingly measured from a surviving vehicle from s SS Pz. Abt 501 abandoned by German troops in 1944 during the Battle of the Bulge, currently in storage at the U.S. Armor & Cavalry Museum at Ft. Benning, Georgia. In addition, the remaining vehicles of the King Tiger were carefully researched and are included in our collection as well.

03.02.2013S

READ BEFORE ASSEMBLY

CAUTION

- Read carefully and fully understand the instructions before commencing assembly. A supervising adult should also read the instructions if a child assembles the model.
- When assembling this kit, tools including knives used. Extra care should be taken to avoid personal injury.
- Keep out of reach of small children. Children must not be allowed to suck any part, or pull vinyl bag over their heads.



Optional



Instant Glue
for Metal



Apply Decal



Do Not
Cement



Remove

PAINTS REQUIRED

Color info and profiles by Mig Jimenez

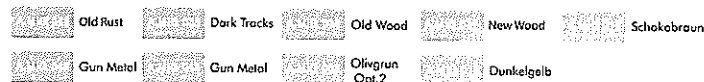

APPLYING DECALS

1. Clean the model surface with a wet cloth.
2. Cut out each decal design from sheet, and dip it in tepid water for 15~20 sec.
3. Hold the backing sheet edge and slide decal onto the model.
4. Move decal into position by wetting decal with finger.
5. Press decal gently down with a soft cloth until excess water and air bubbles are gone.

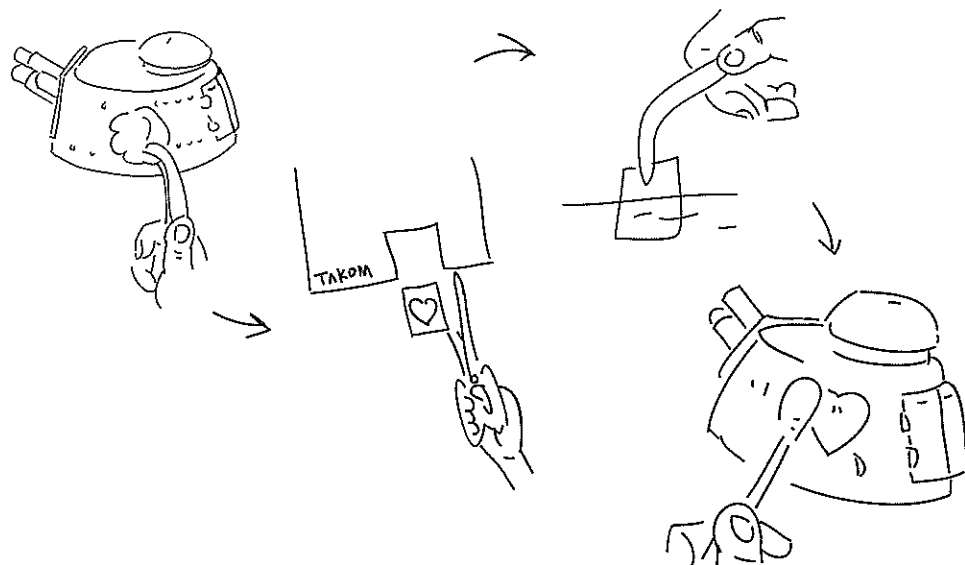

REMOVING PE

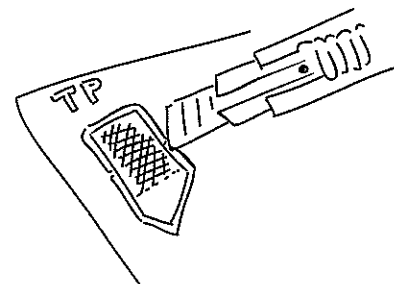

Be careful not to hurt when removing PE parts.

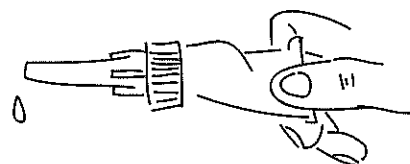

Secure using instant glue (not included).

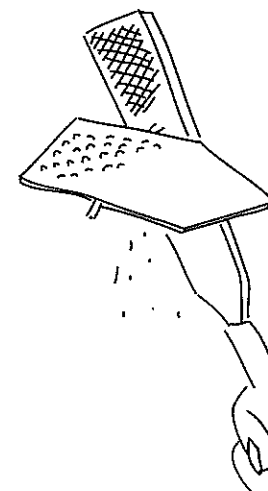

Finish using

PARTS

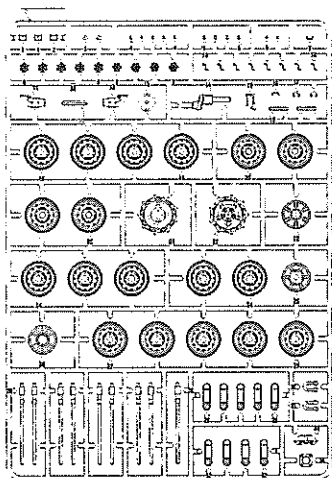

X2

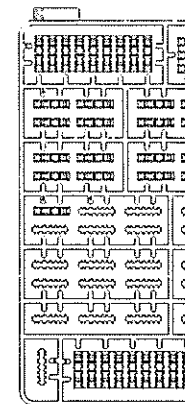
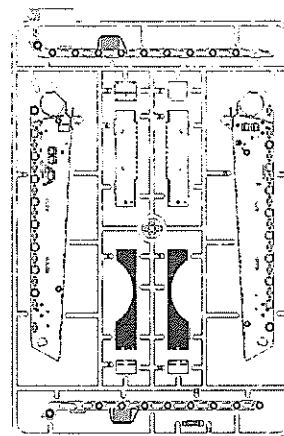
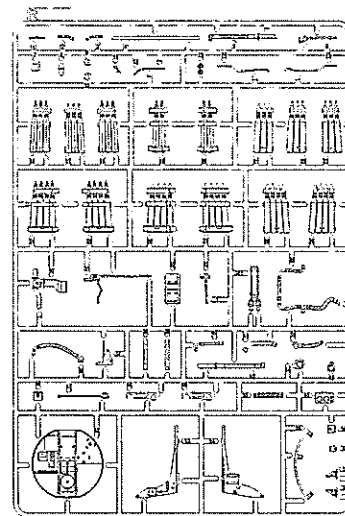
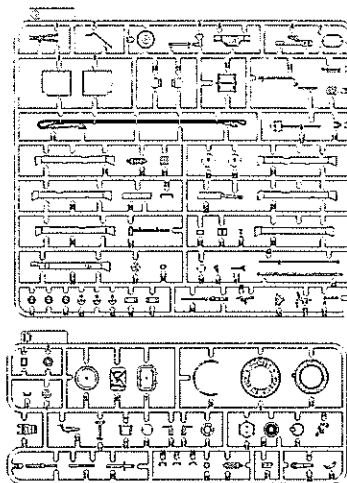
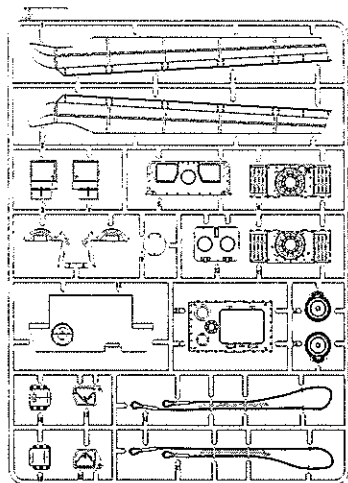

X2

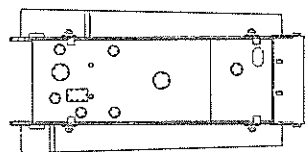
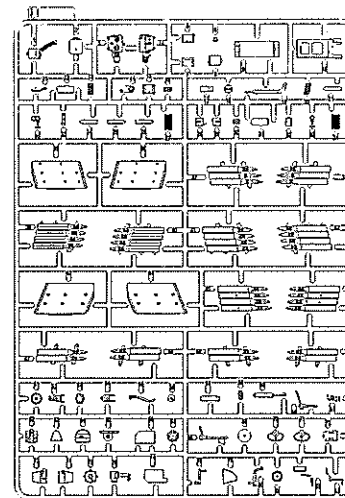
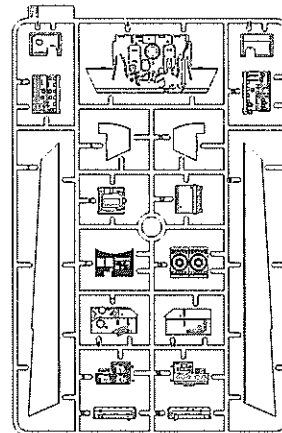
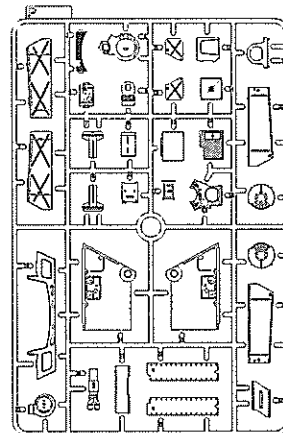
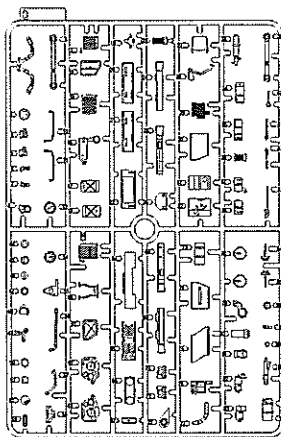
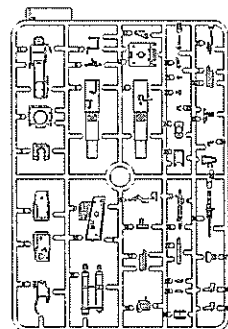
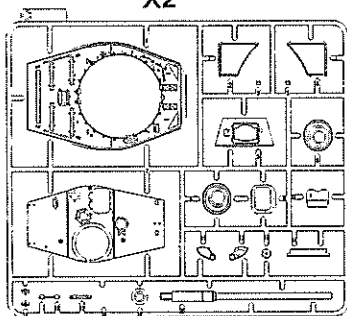

Lower Hull

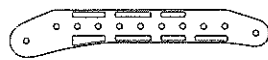

Z1

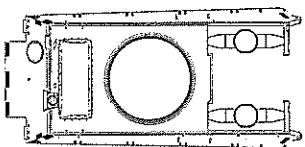

Upper Hull

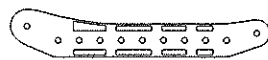

Z2

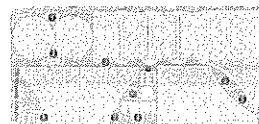
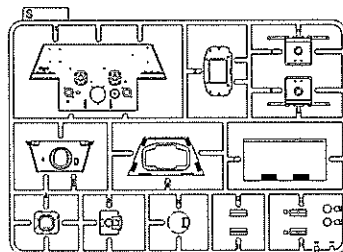

TP

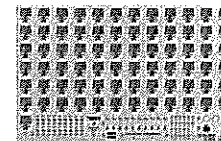

Decal

++1+011+01
211211 324 324
346 304 304
114 114 105 105

1

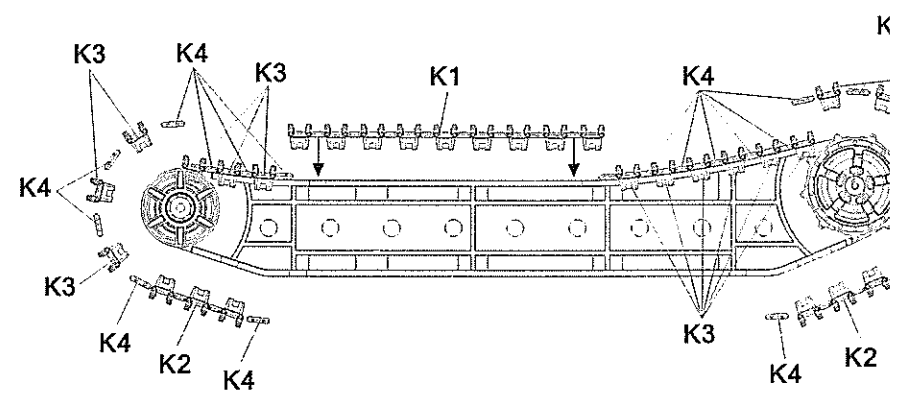
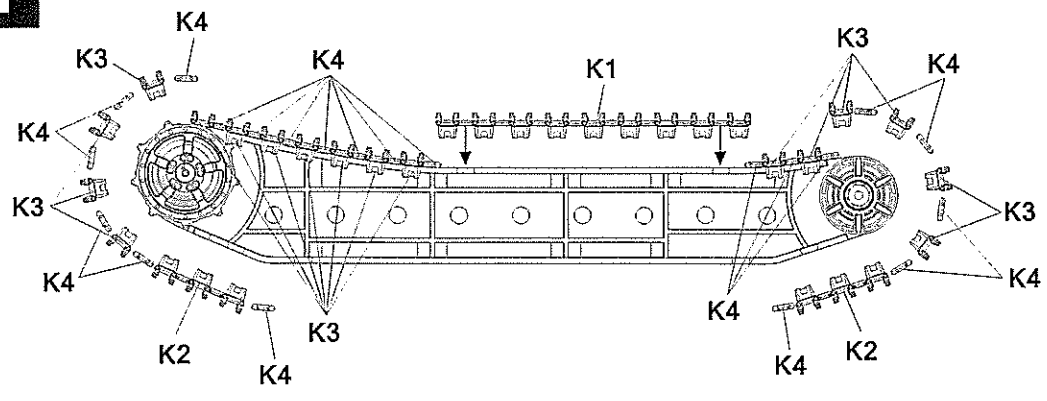

2

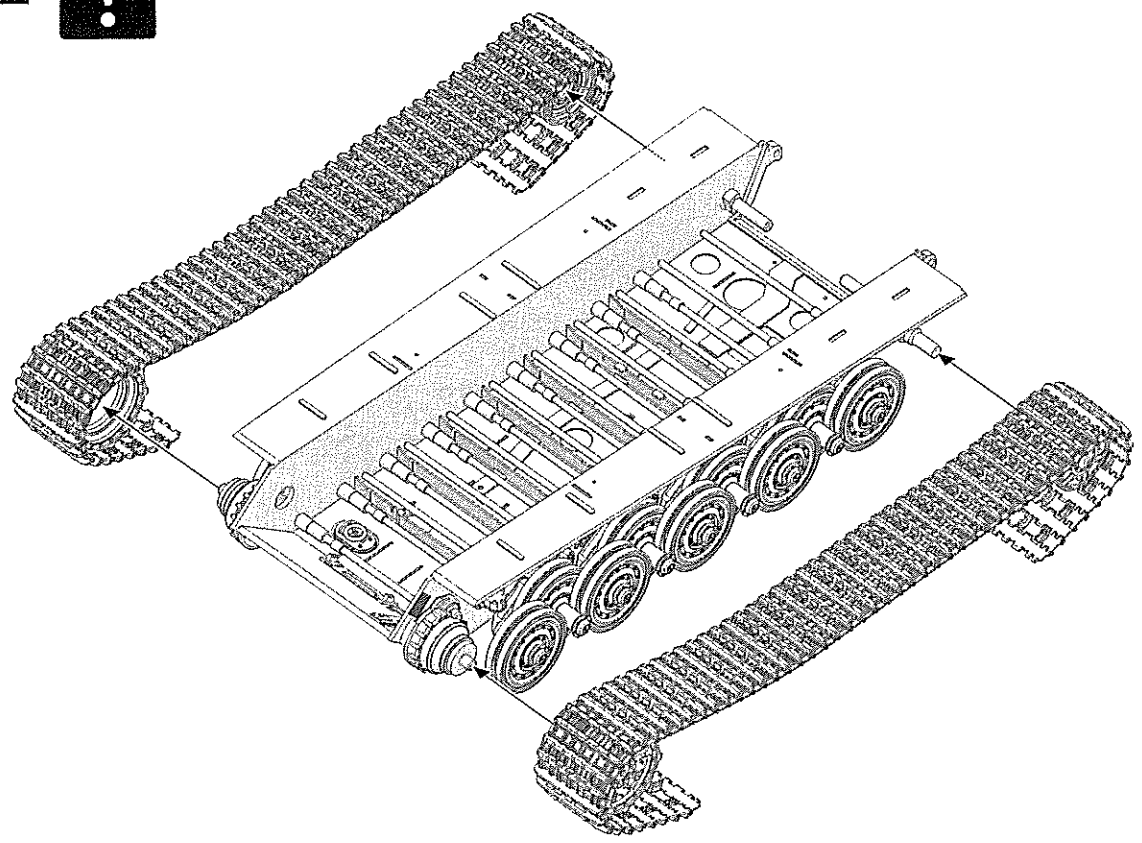

3

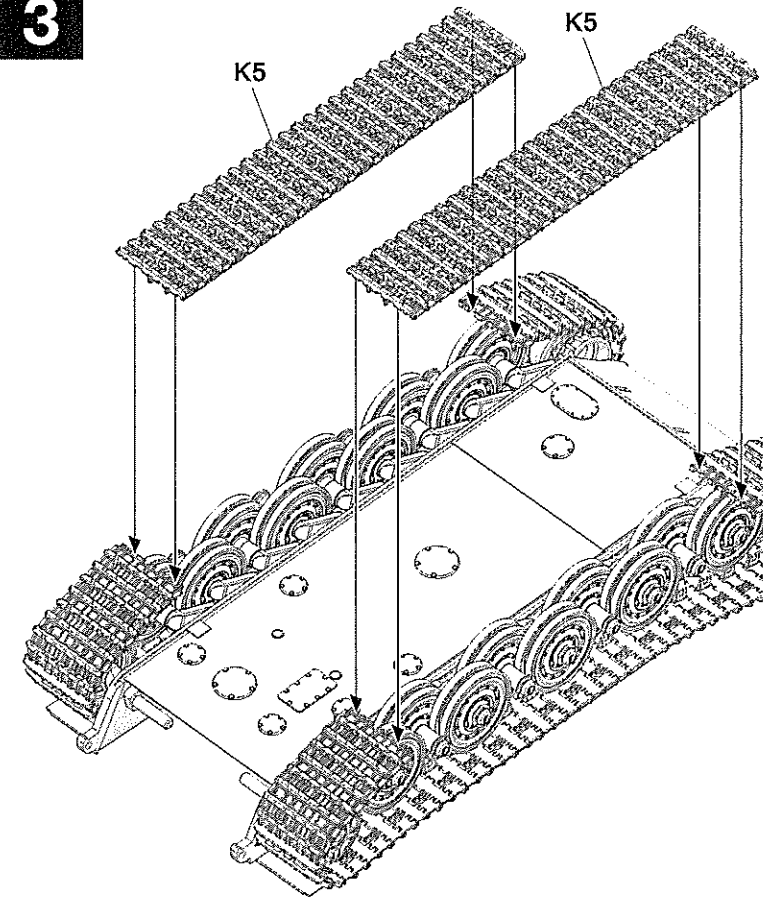

4

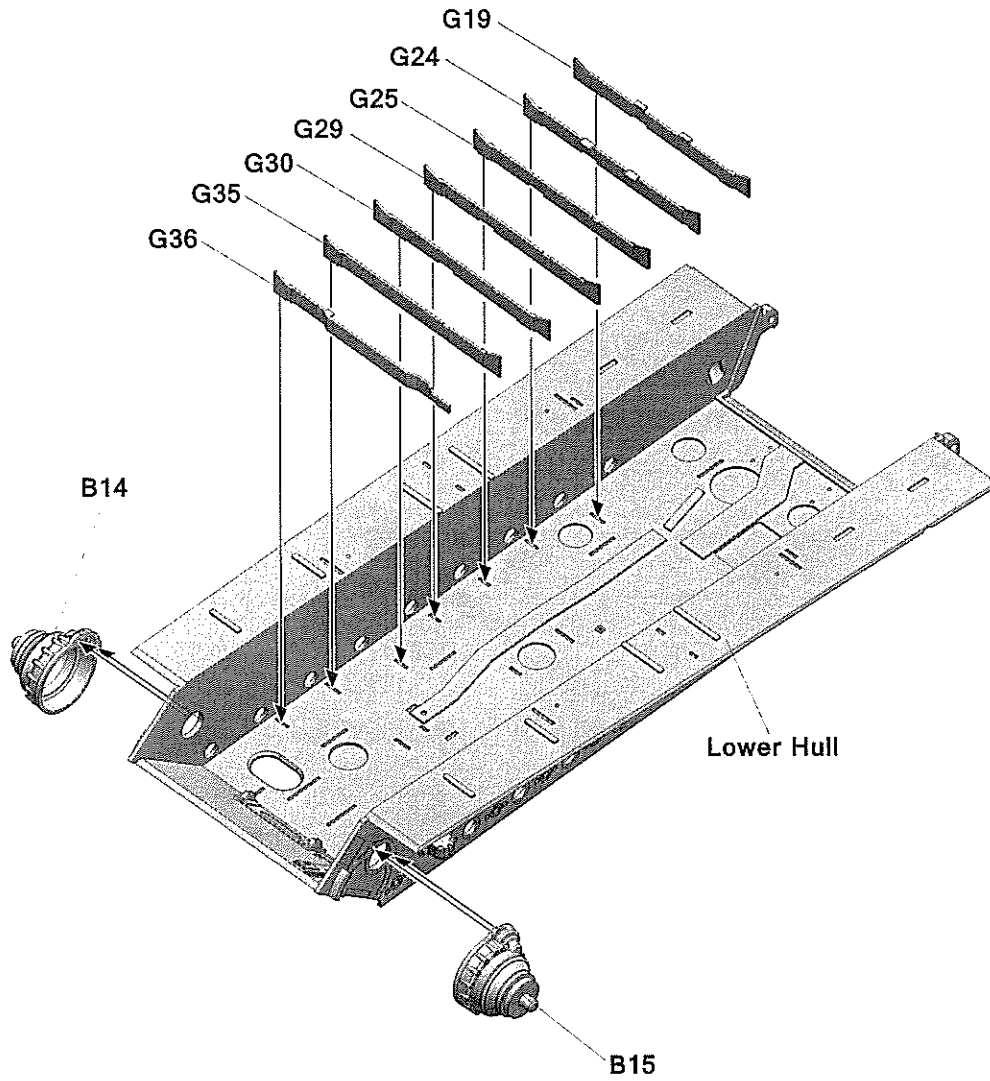

5

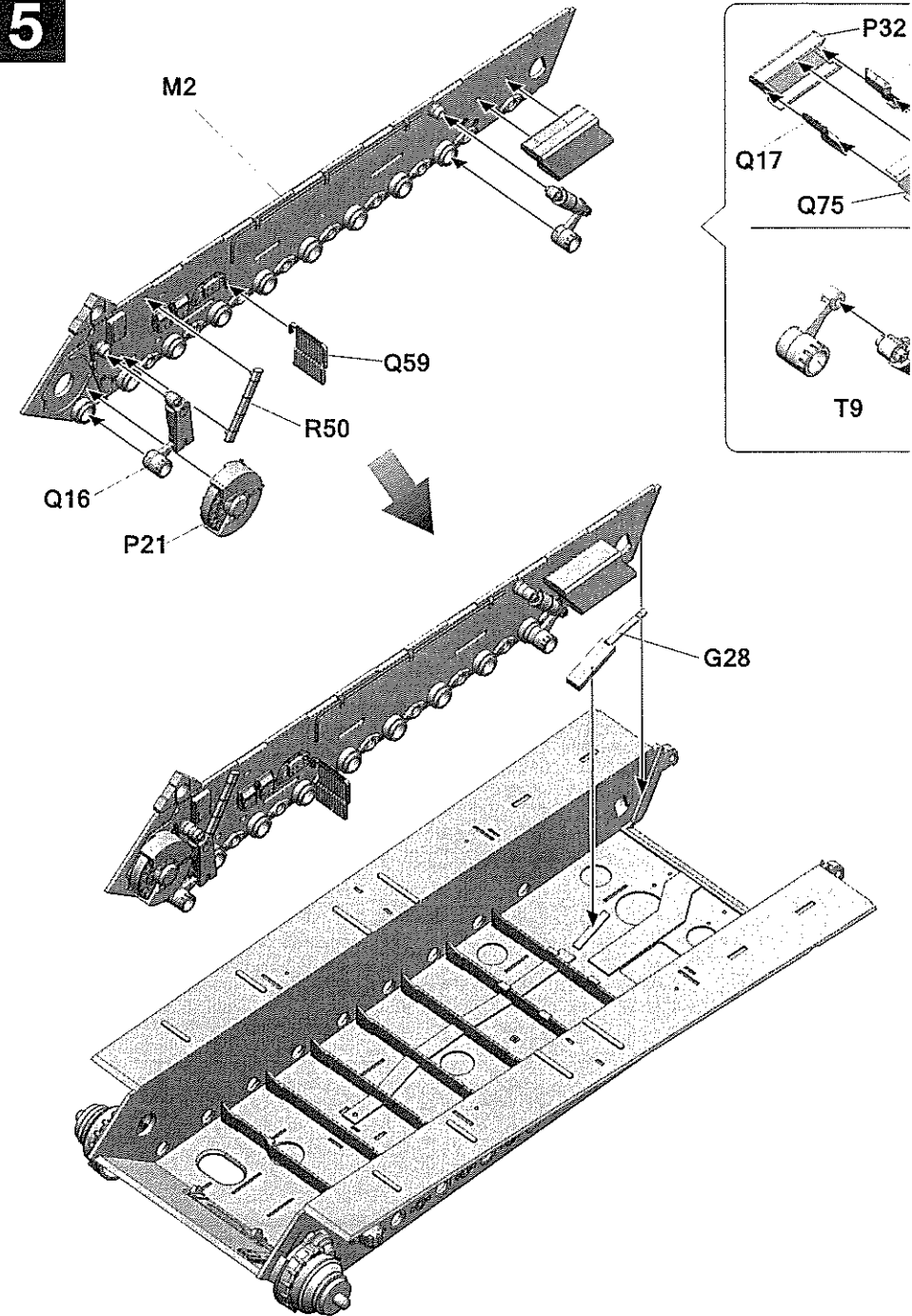

4

6

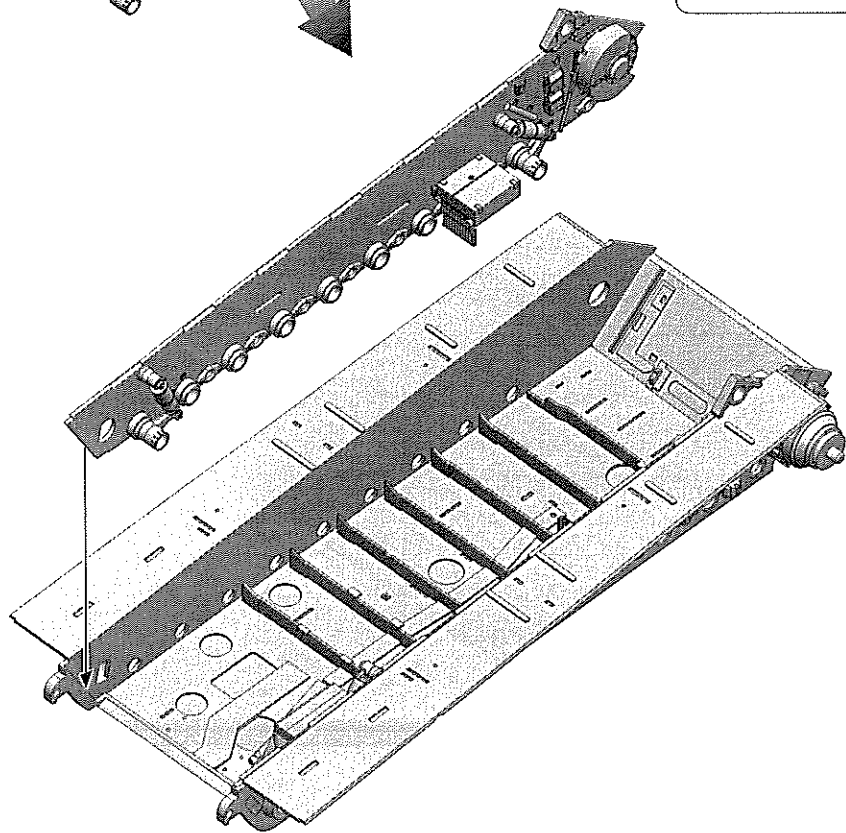
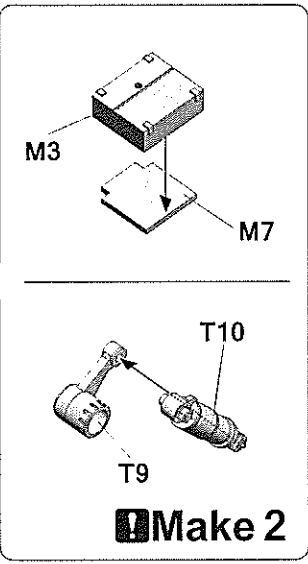
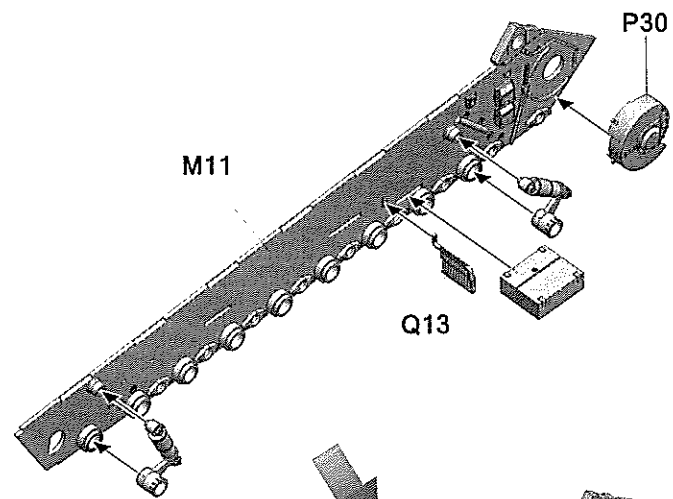

7

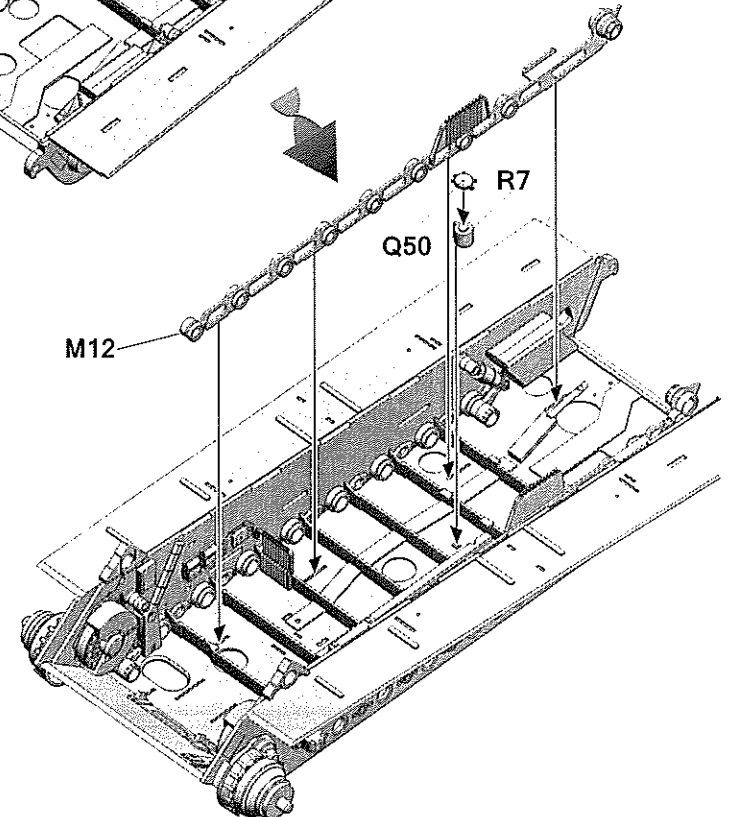
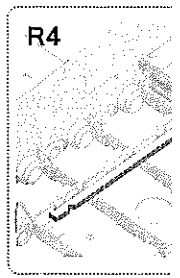
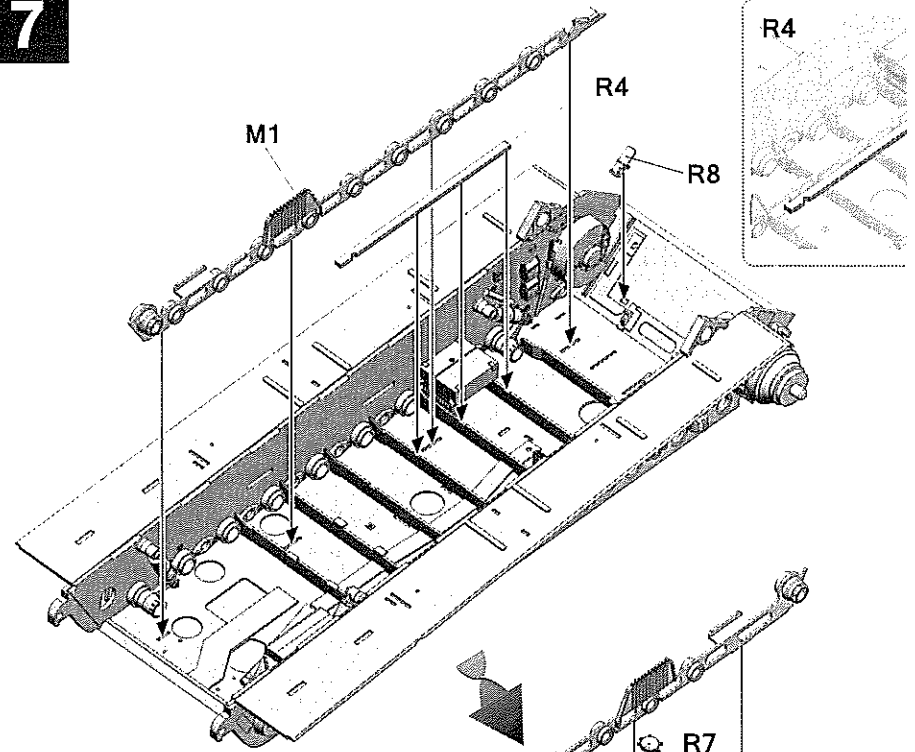

8

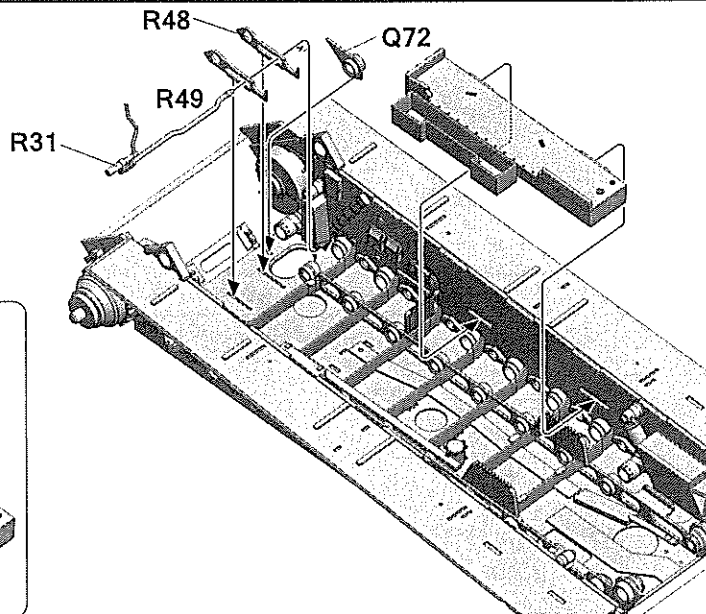

10

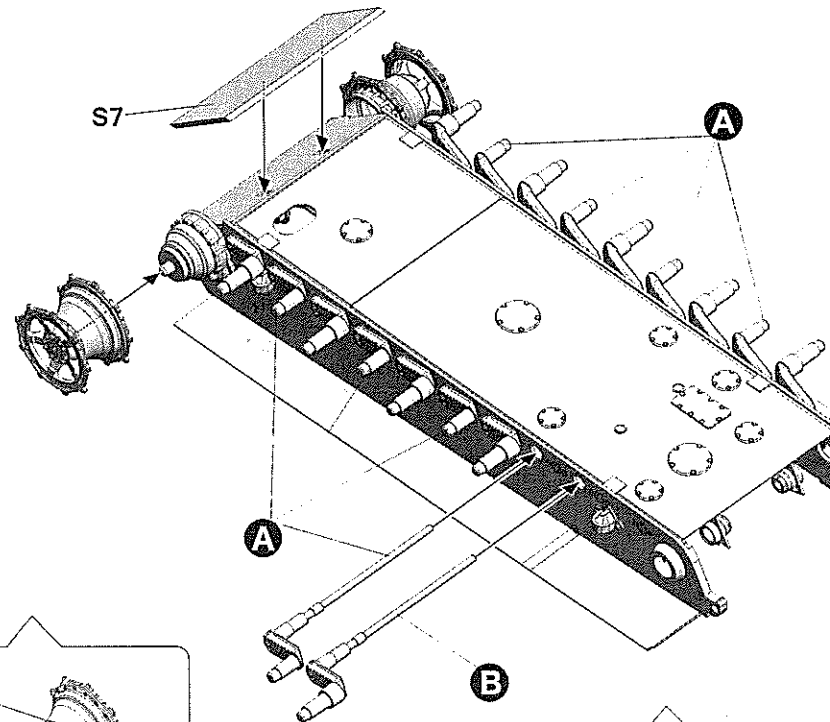

9

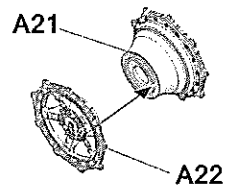
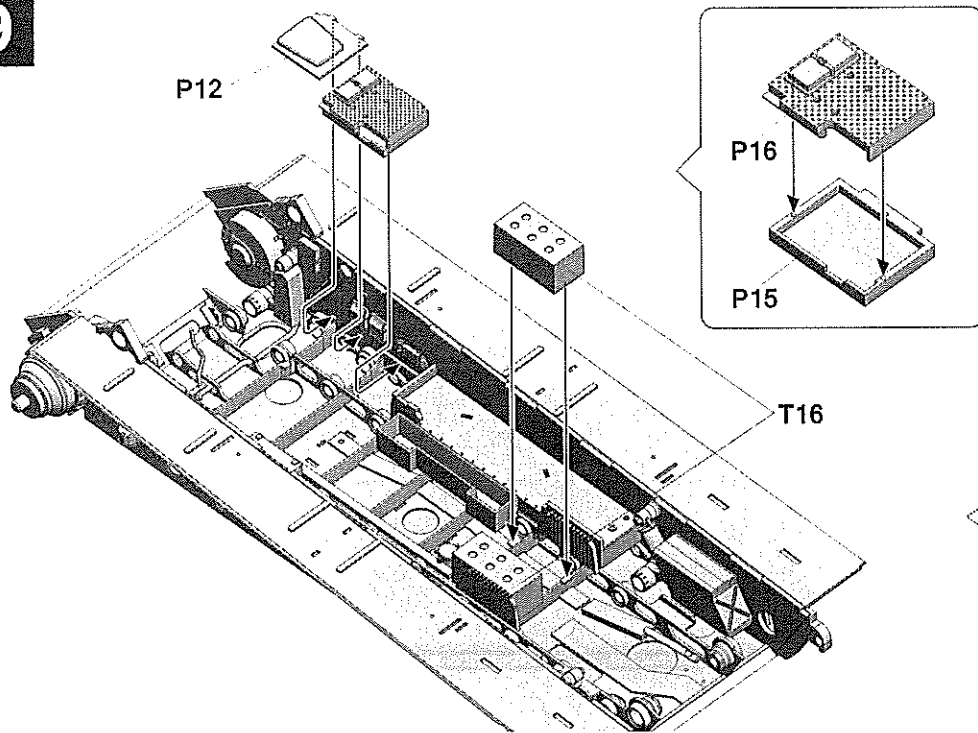

Make 2

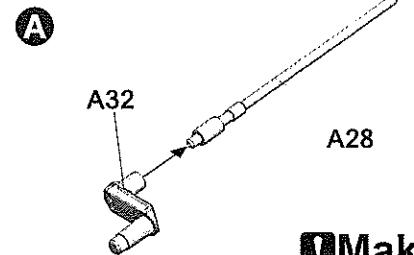

Make

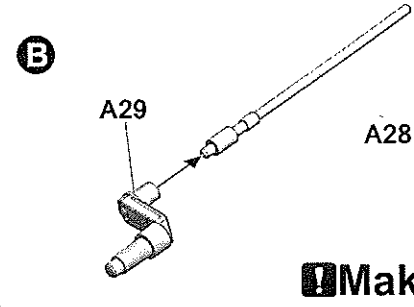

Make

11

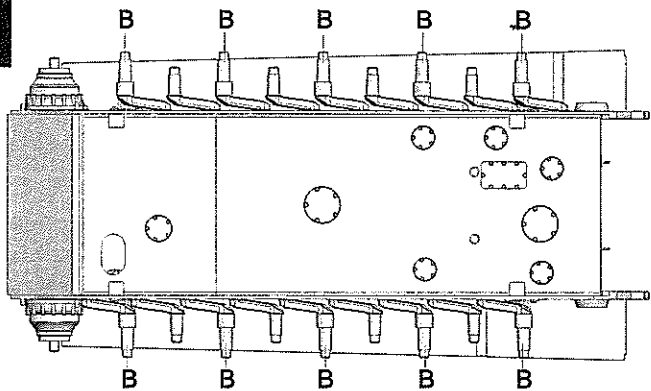

13

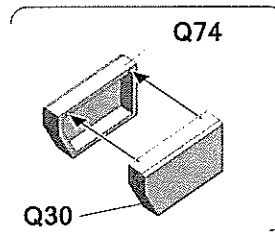

12

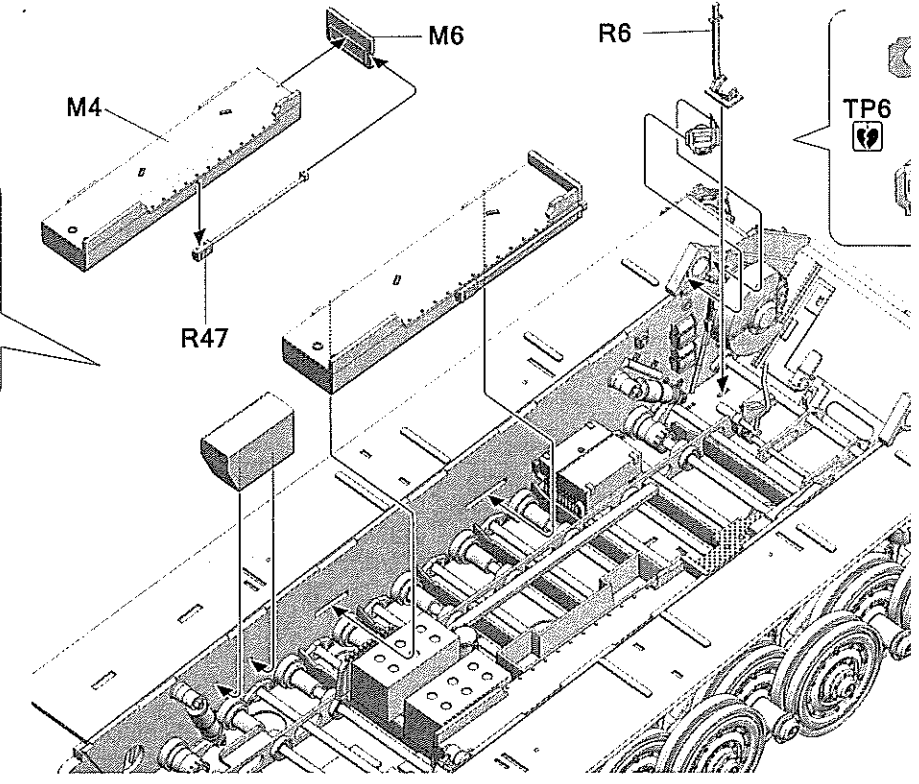
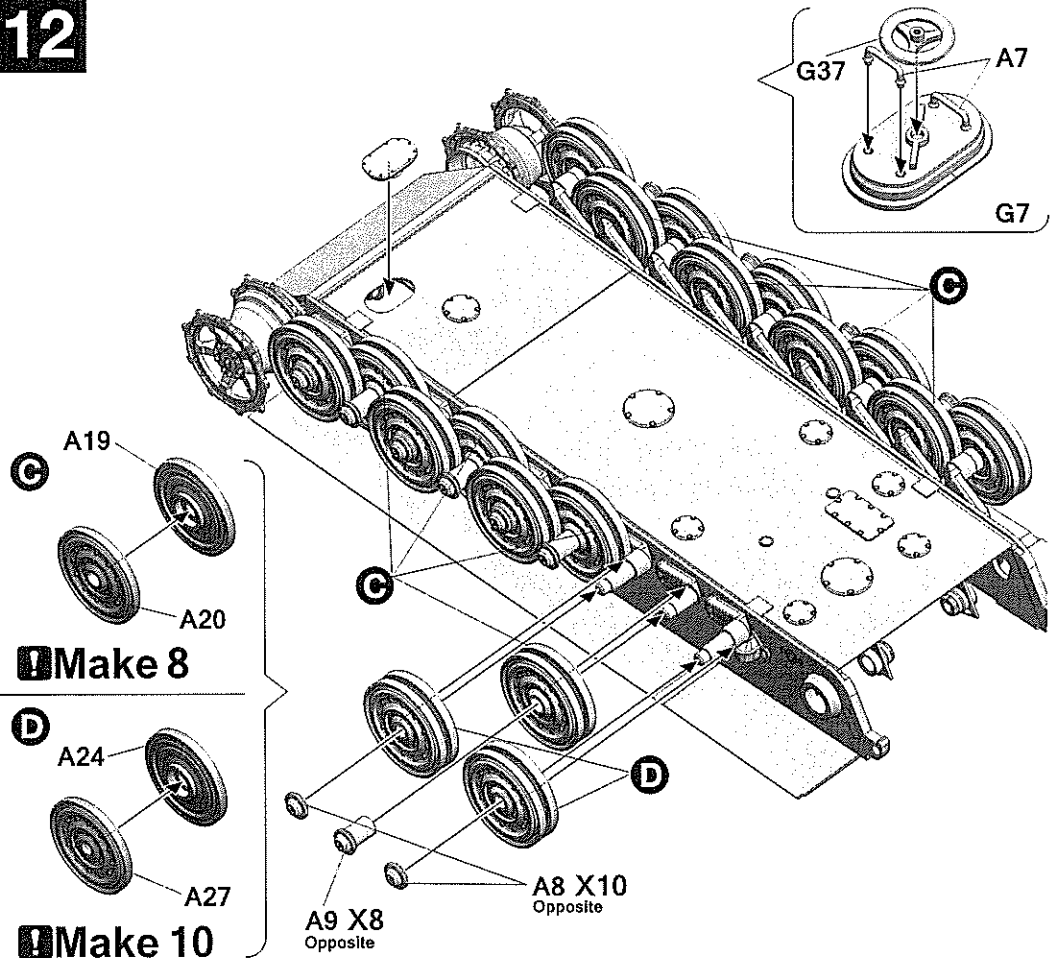

14

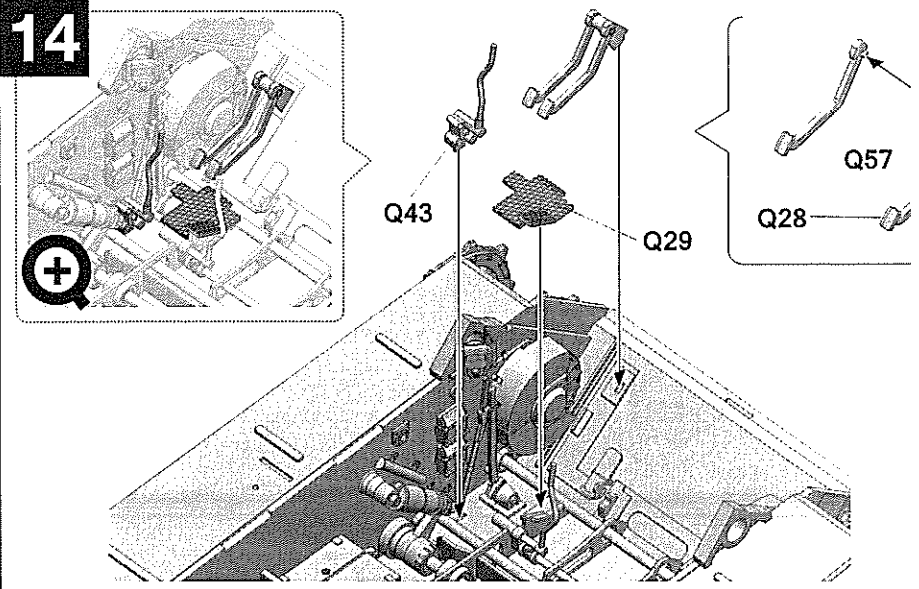

15

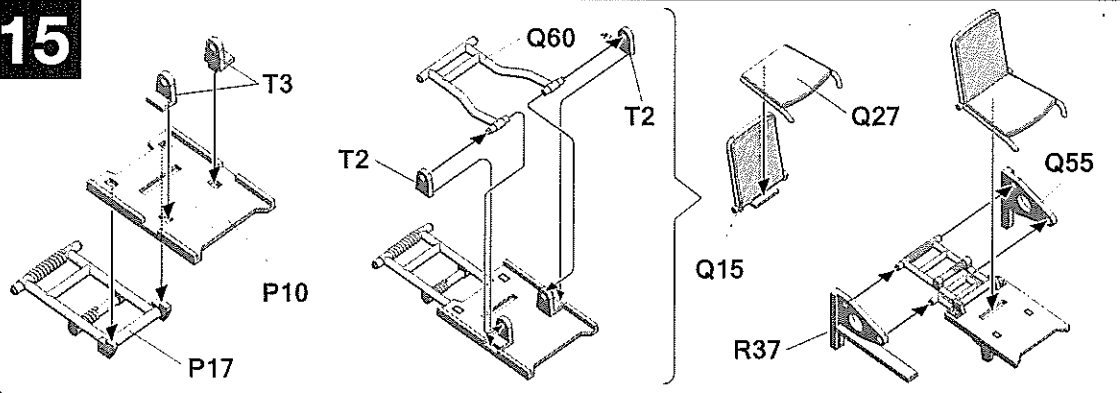

16

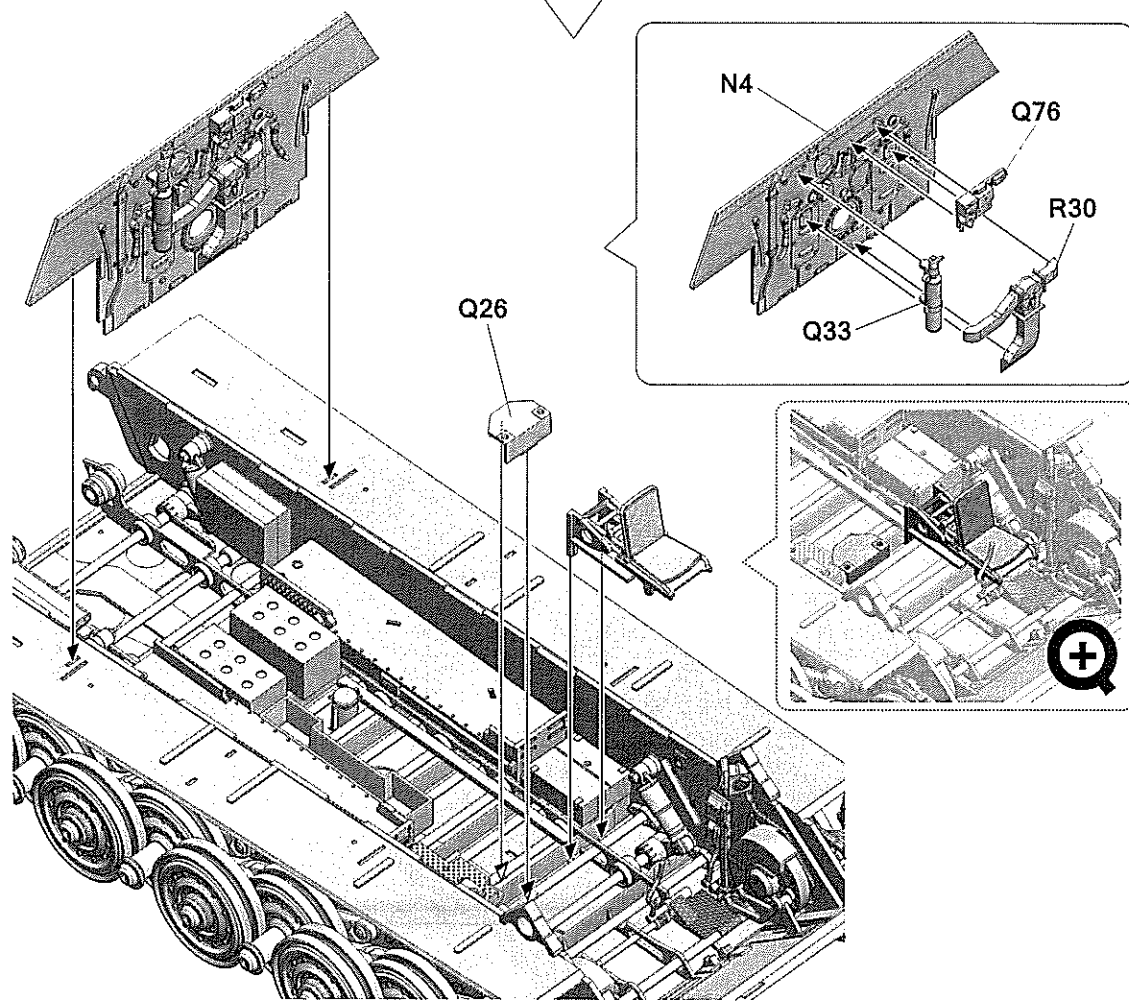
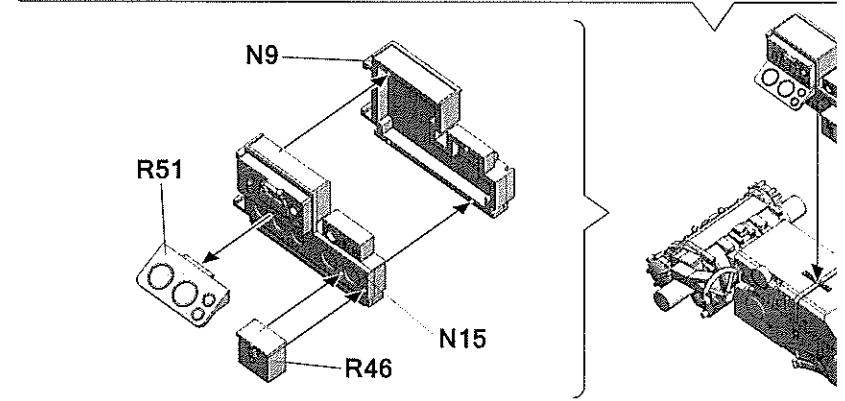
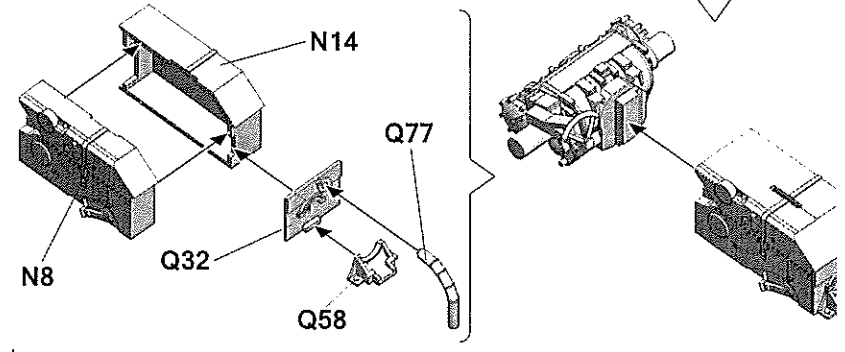
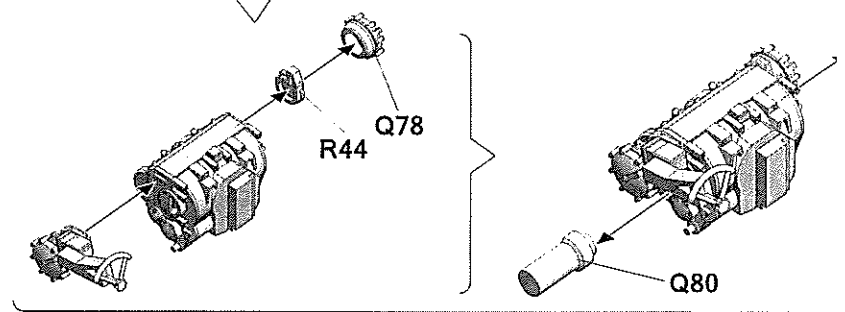
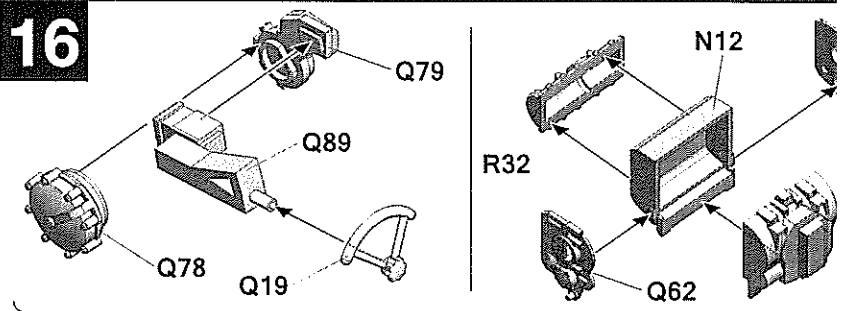

17

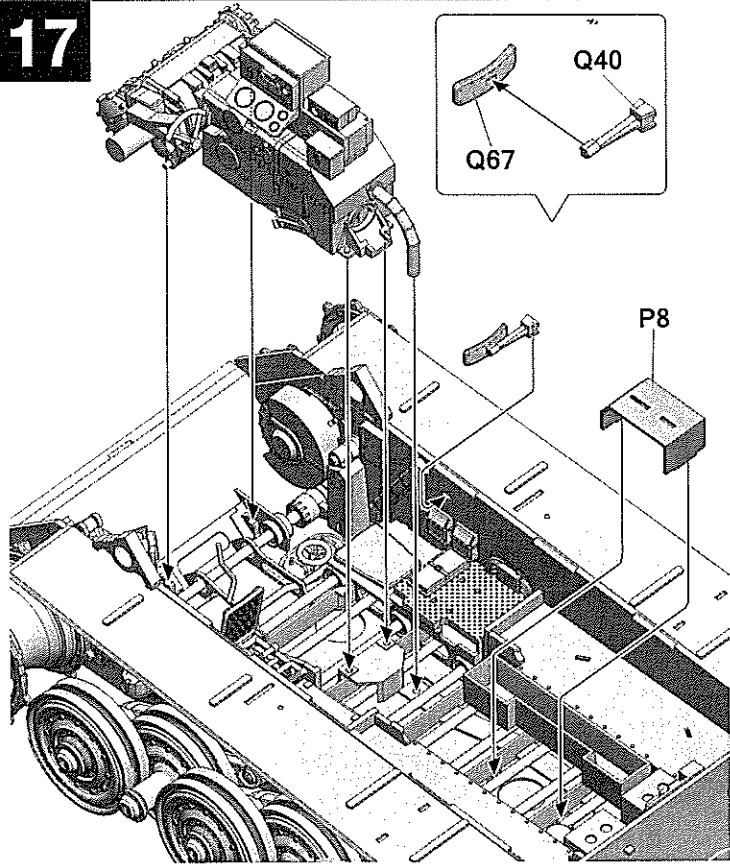

18

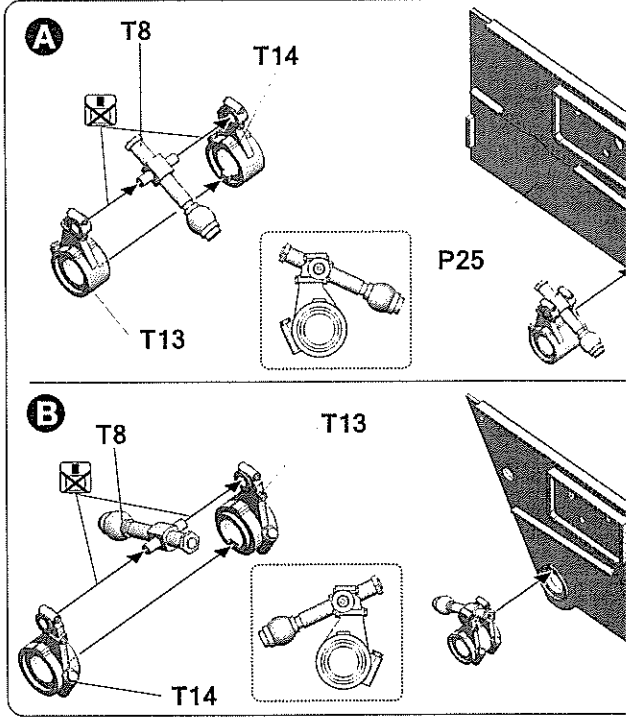
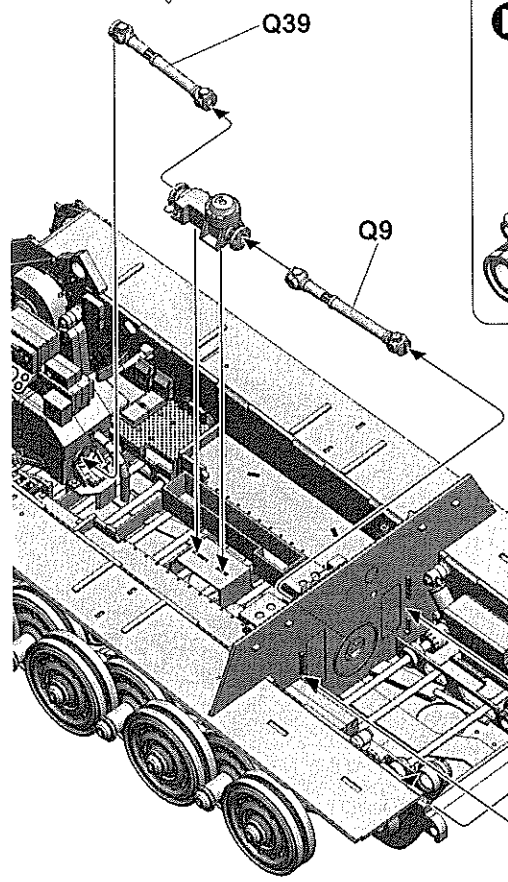
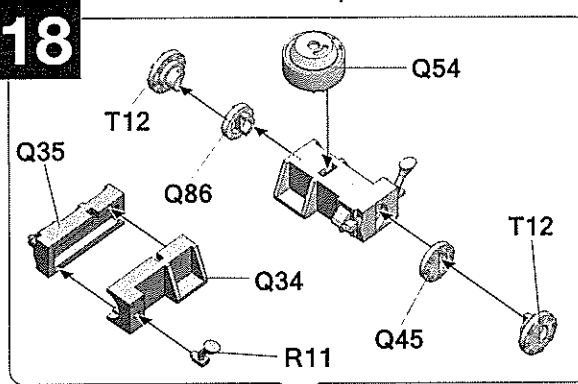

19

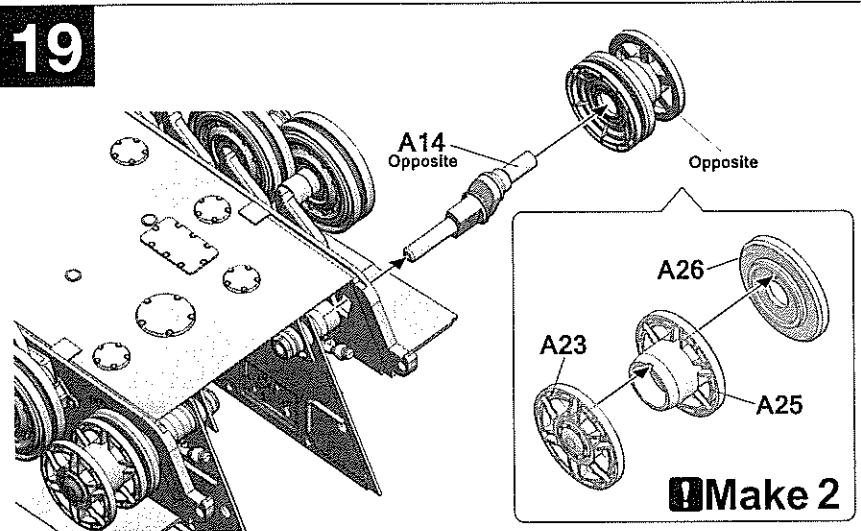

Make 2

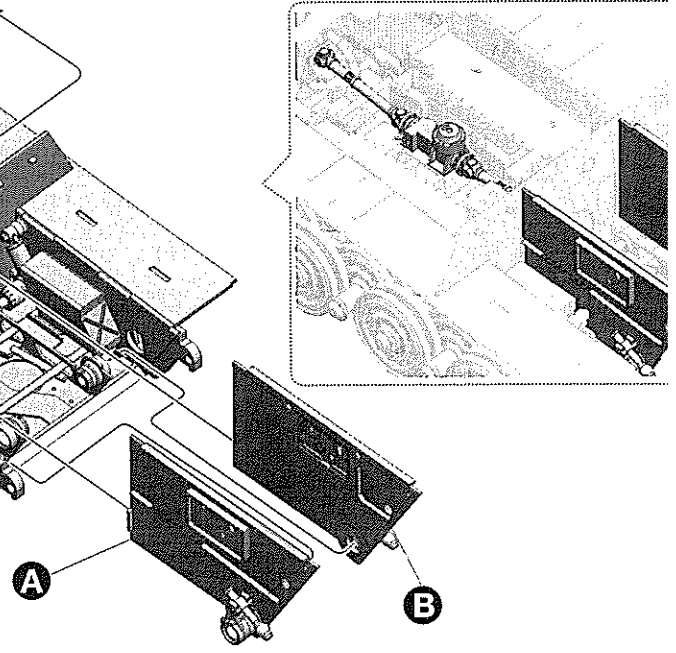

20

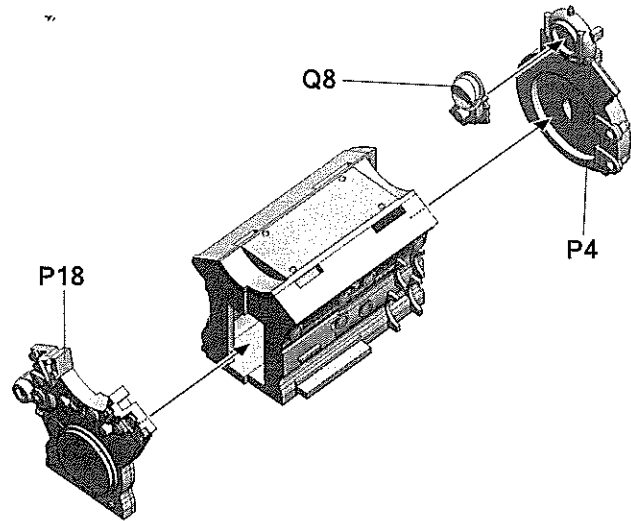
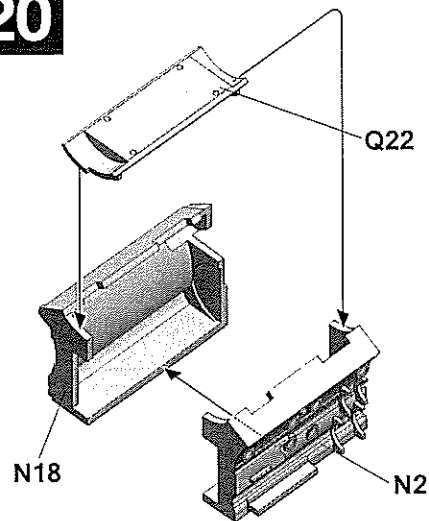

21

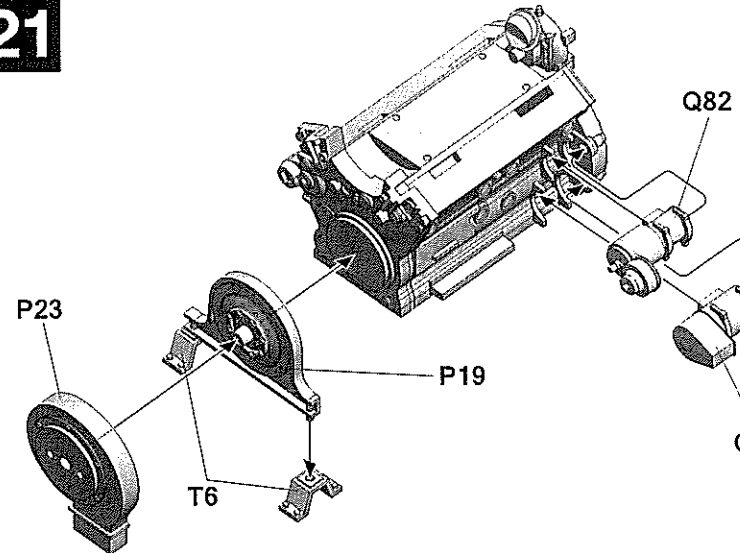

22

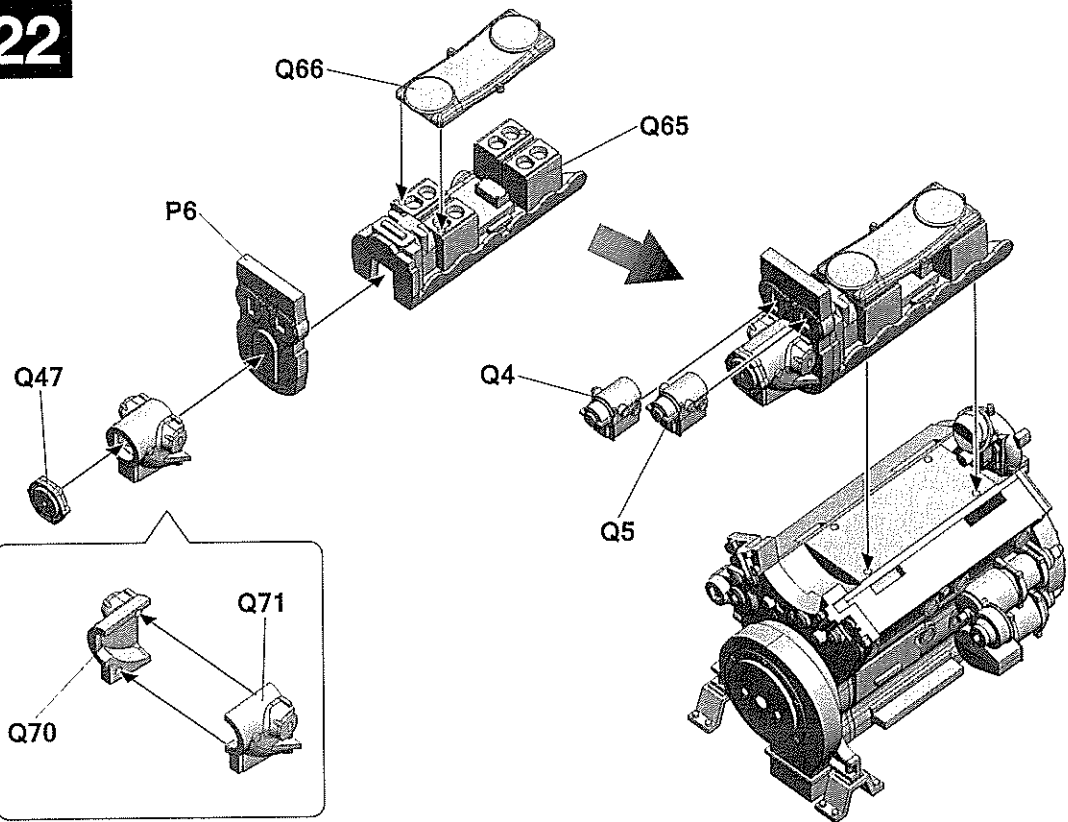

23

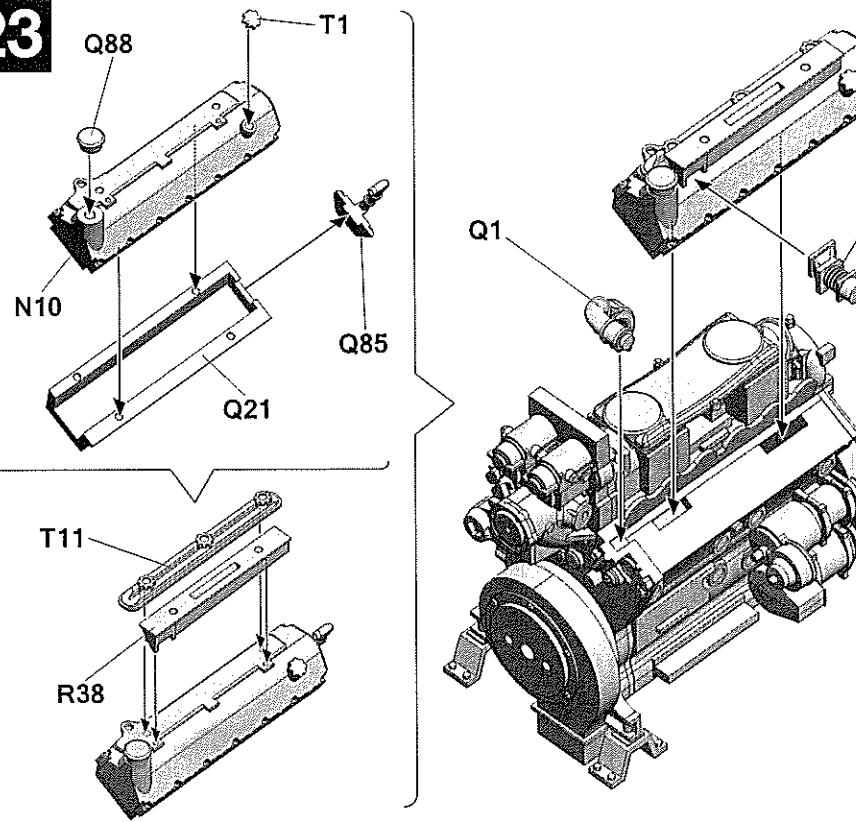

24

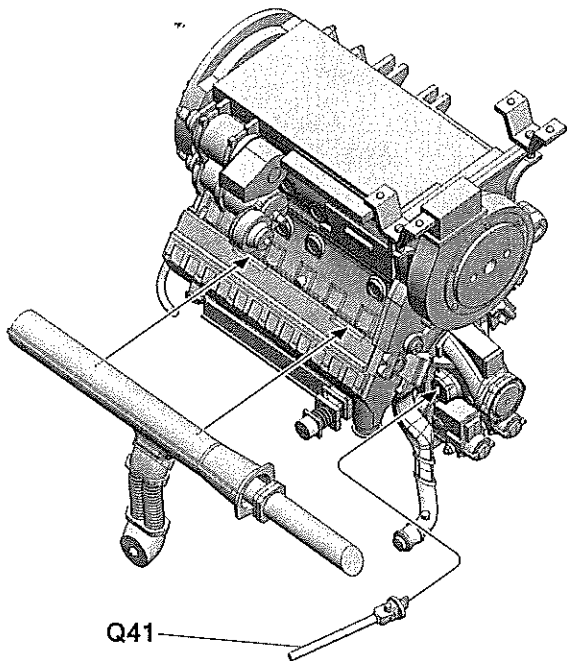
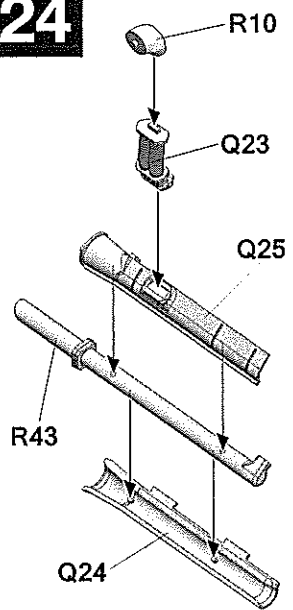

25

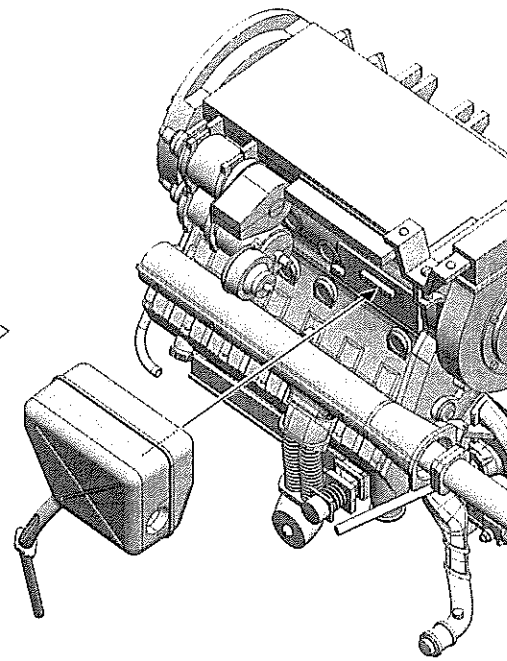
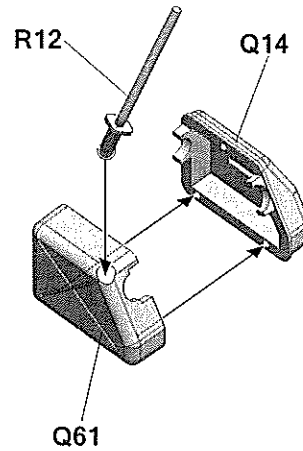

26

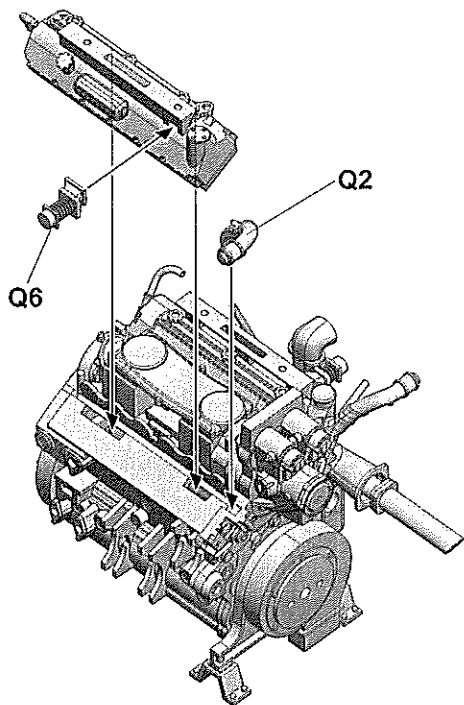
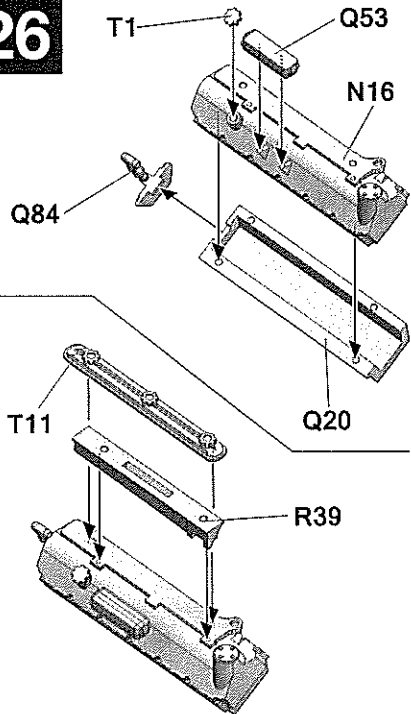

27

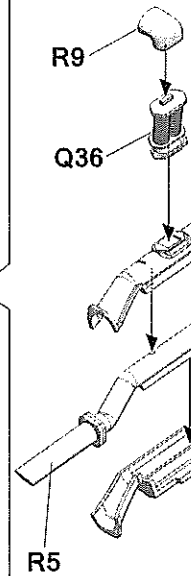
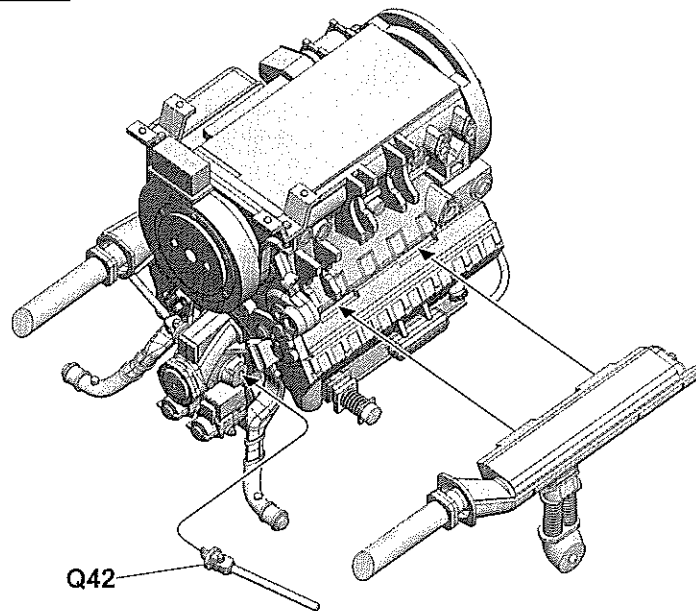

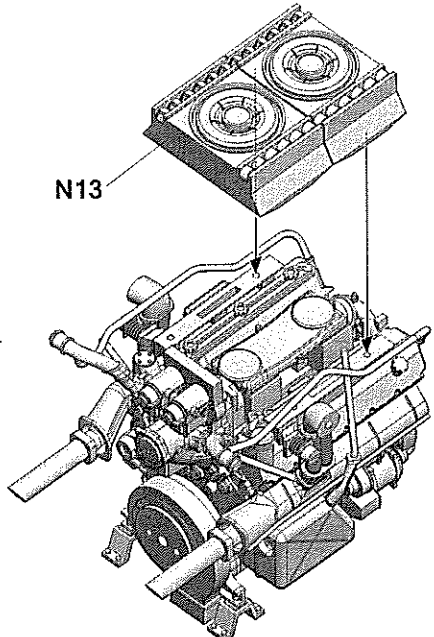
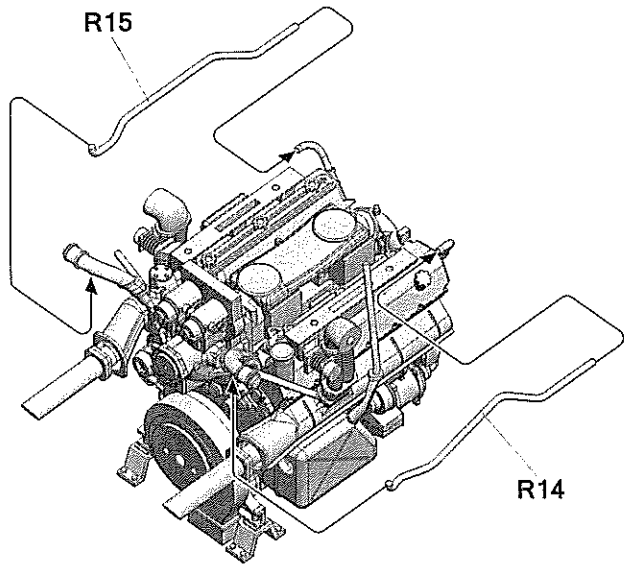
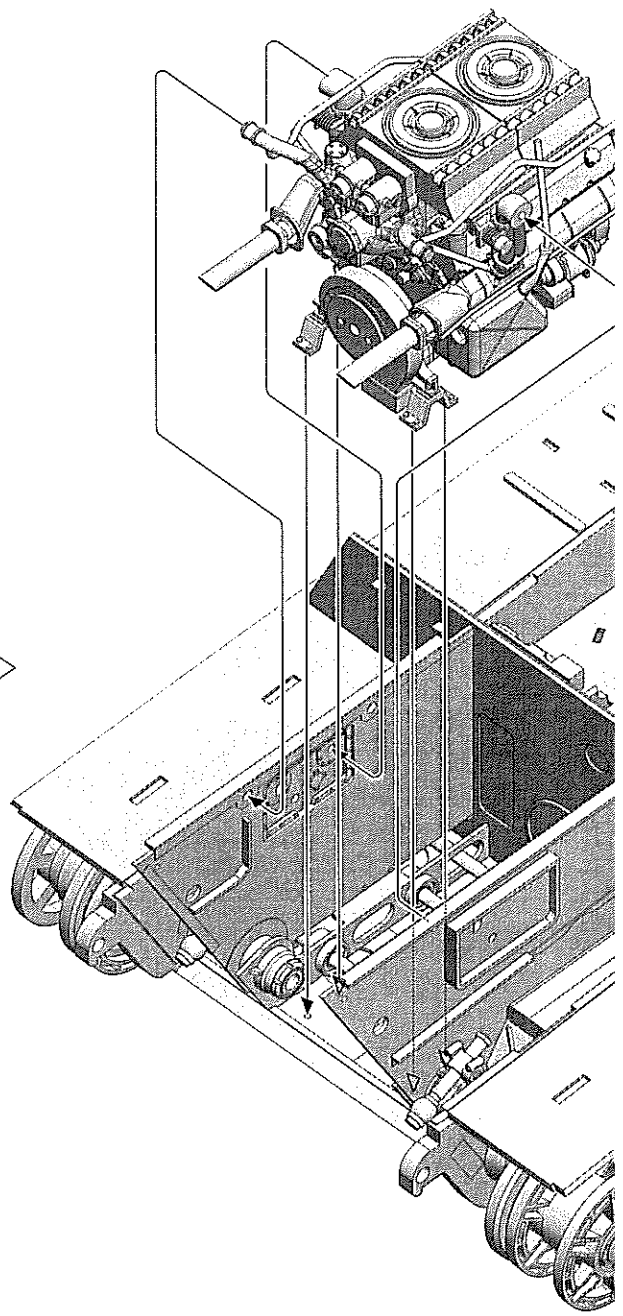
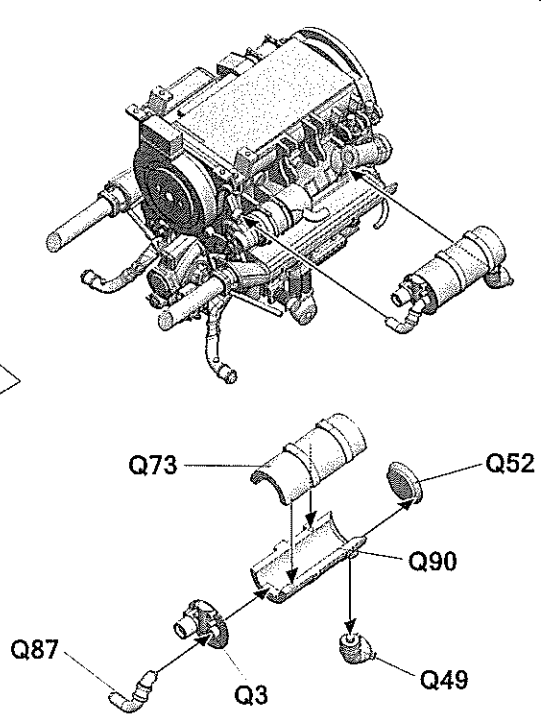
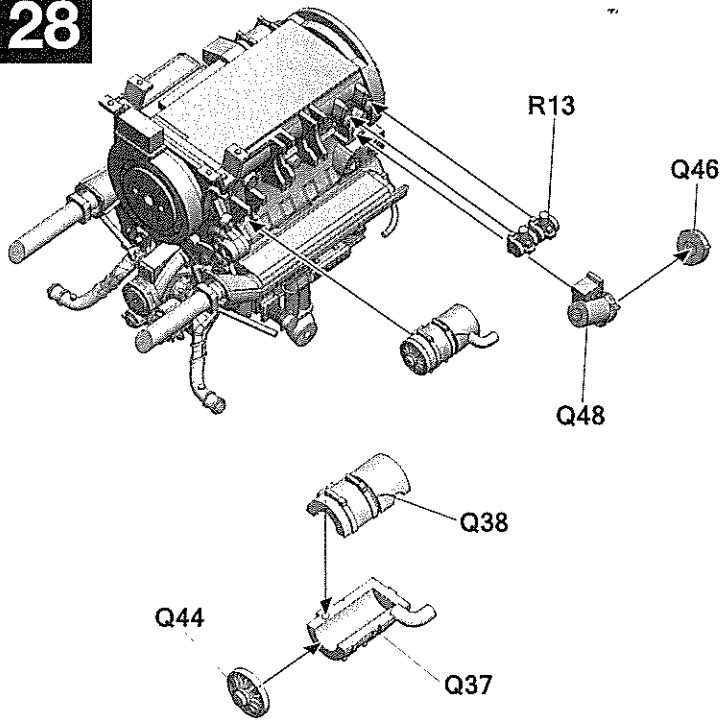

29

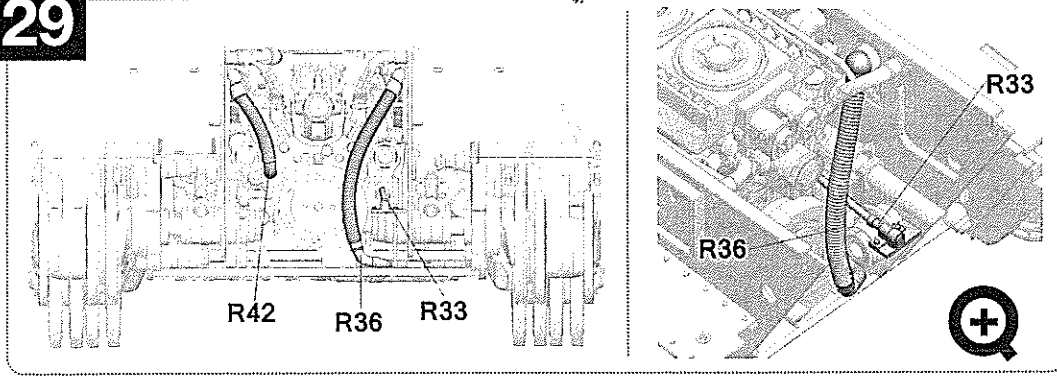

30

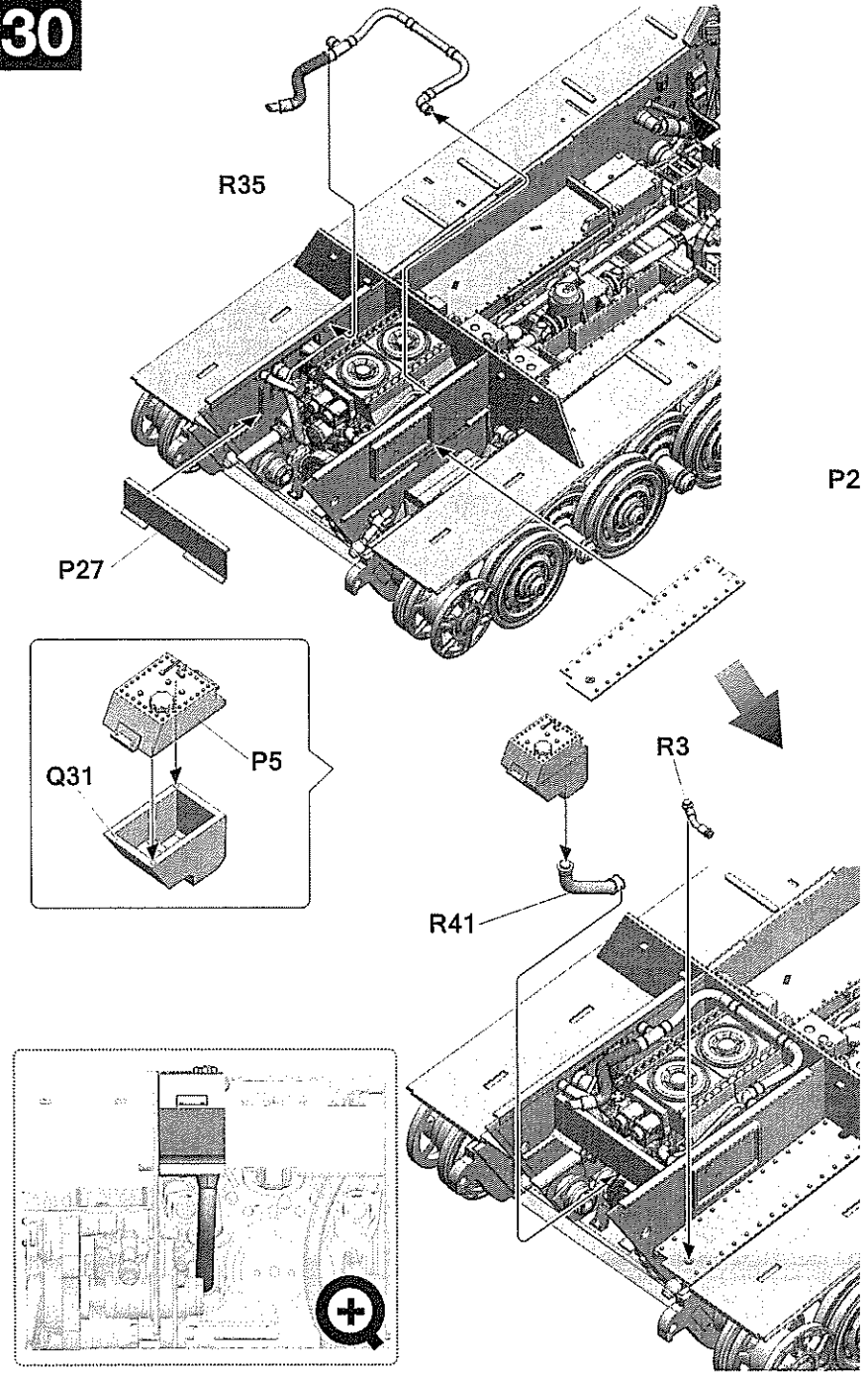
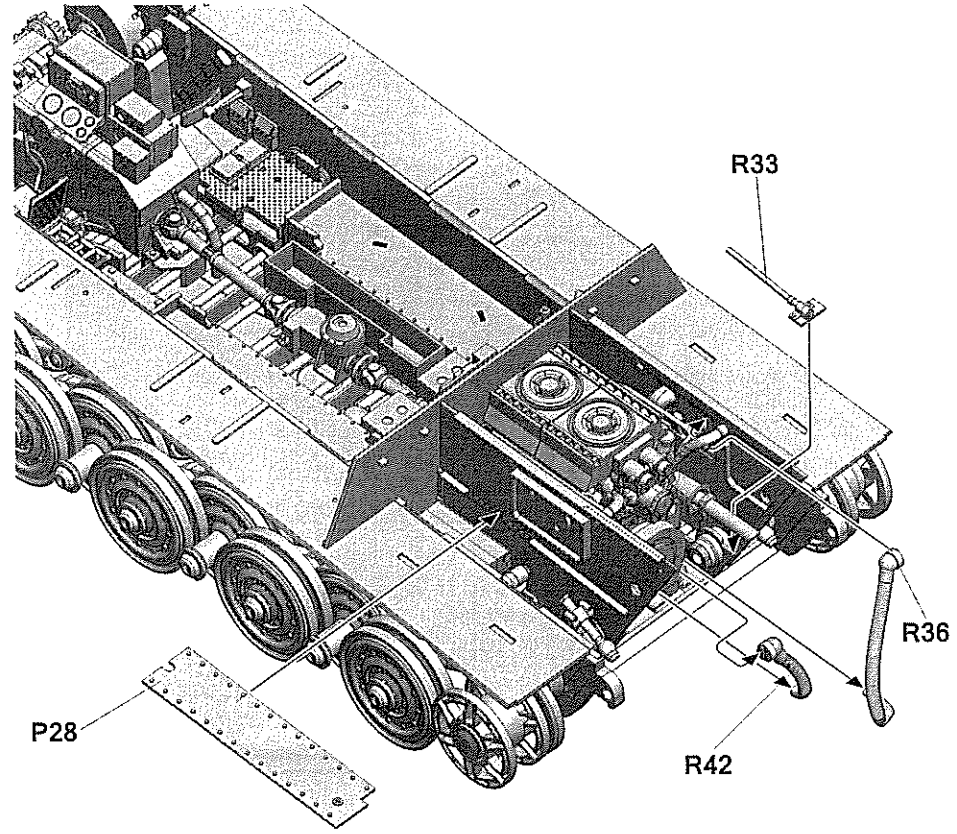

31

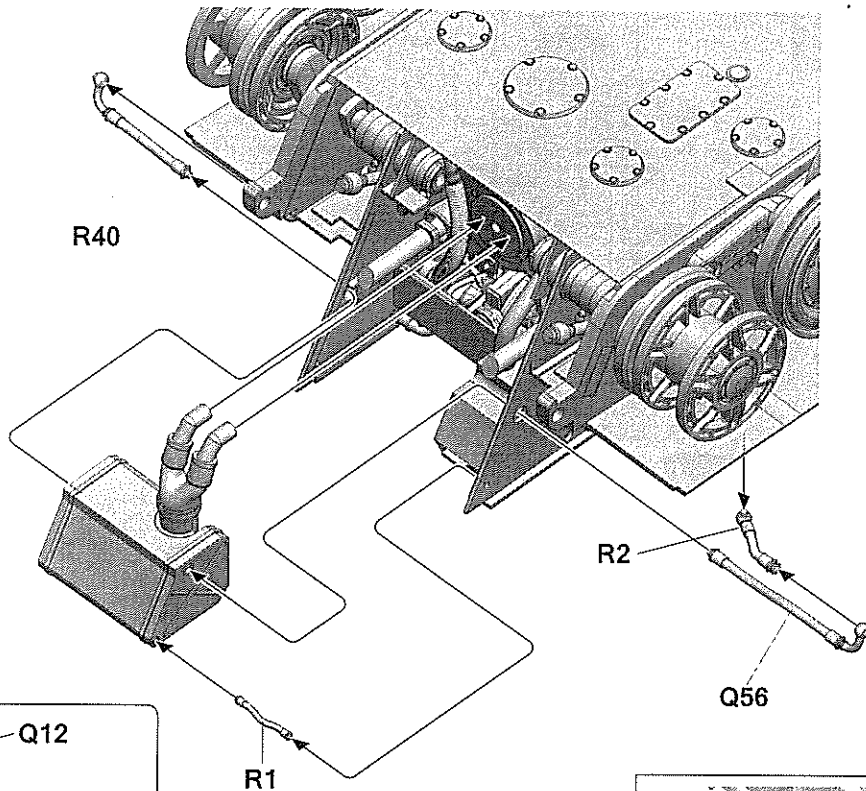

32

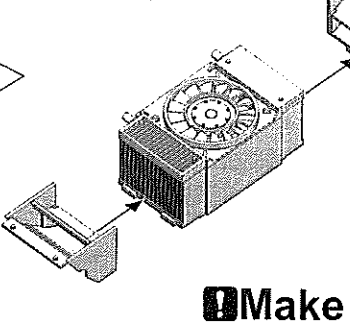
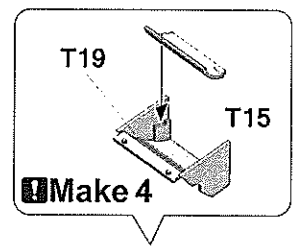
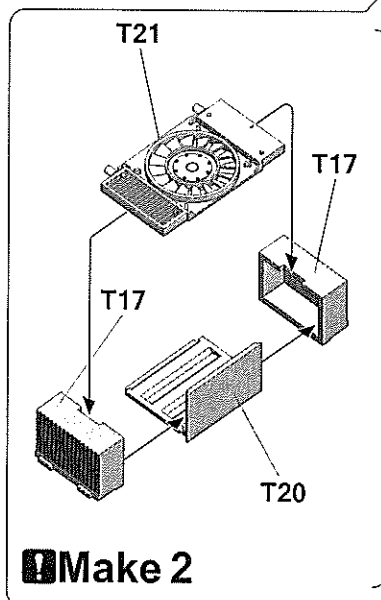
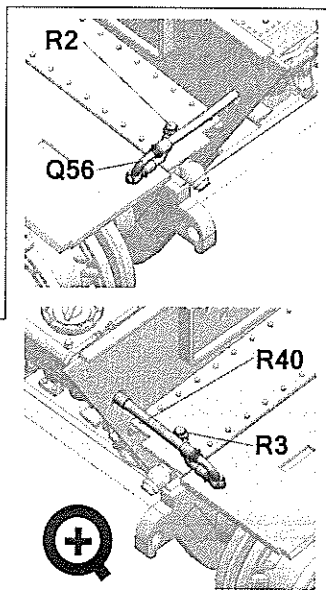
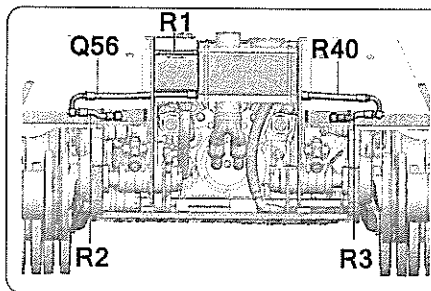
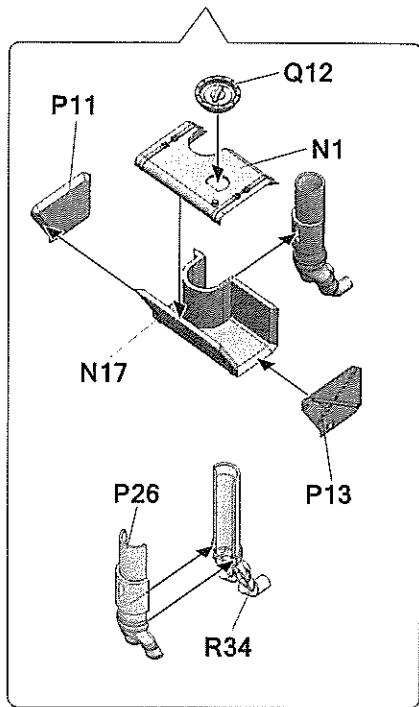
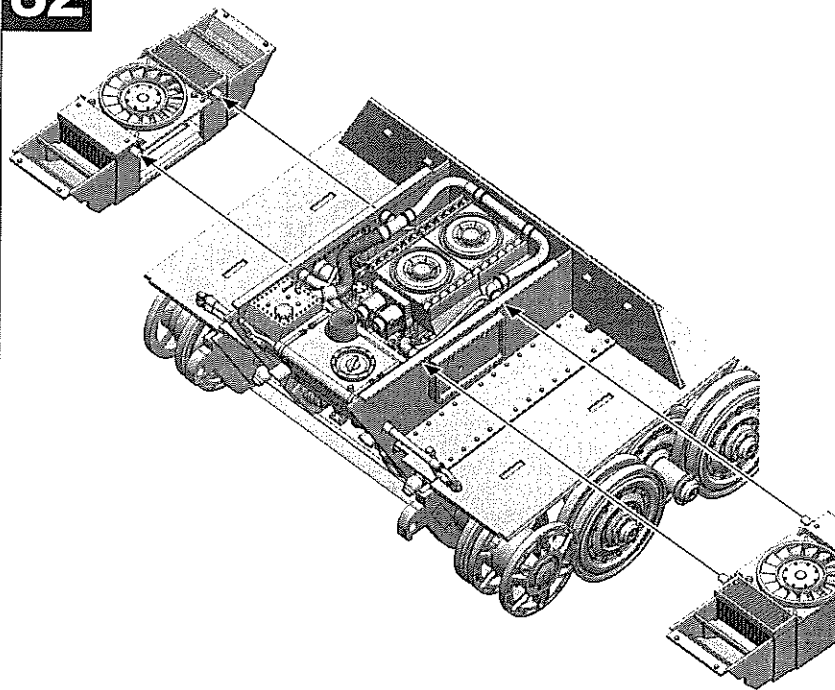

Make 2

Make 4

Make

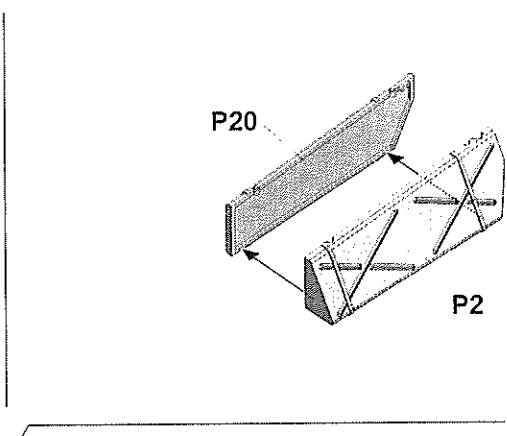
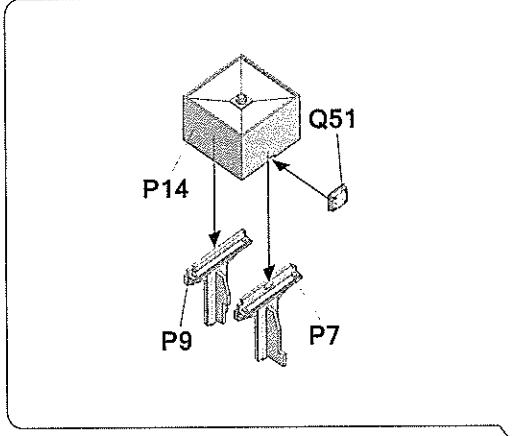
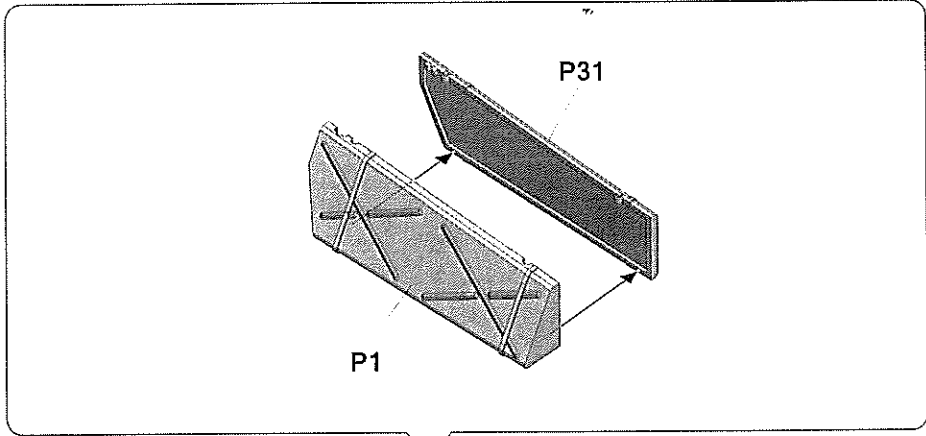

33

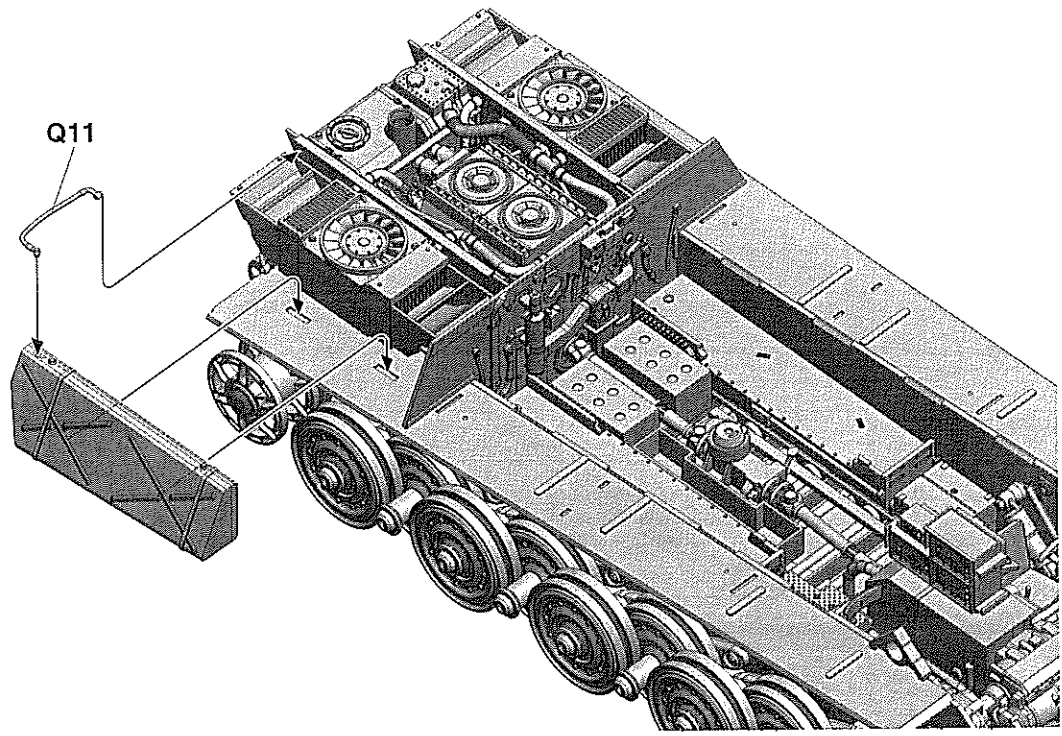

34

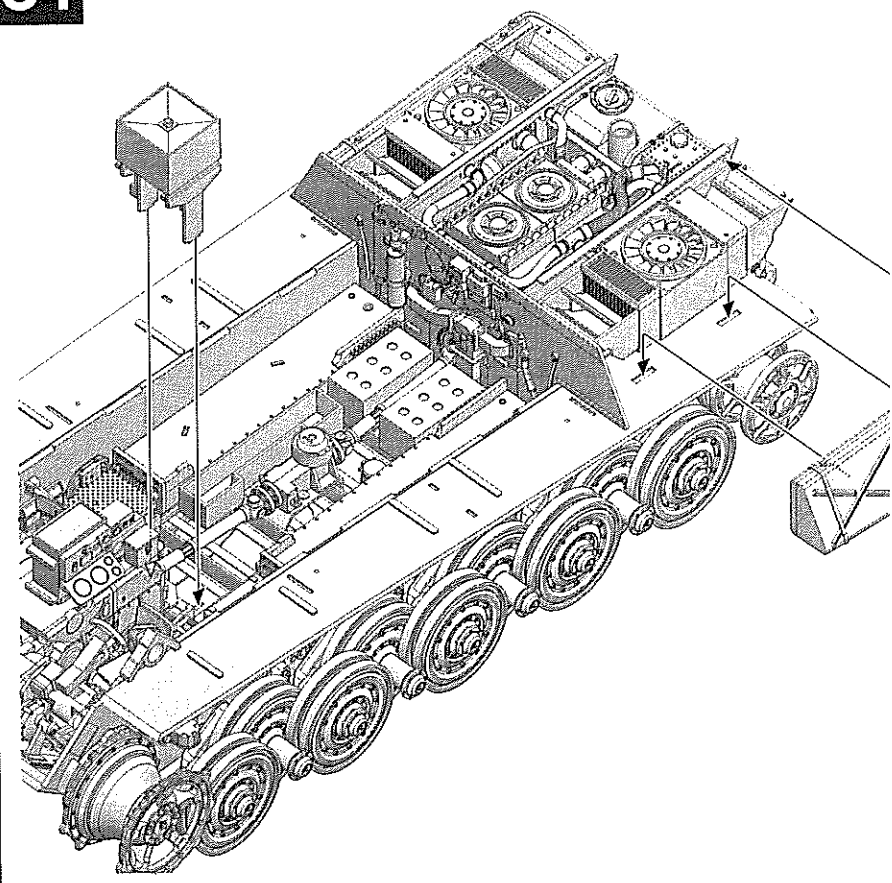

35

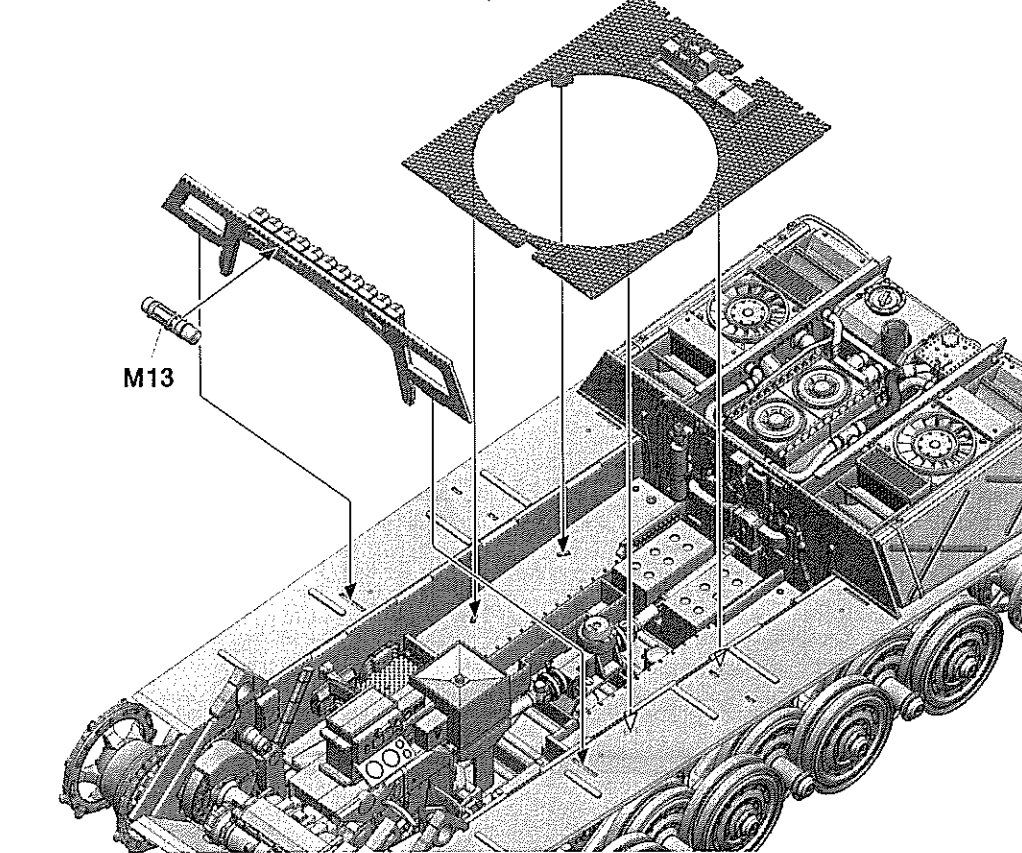
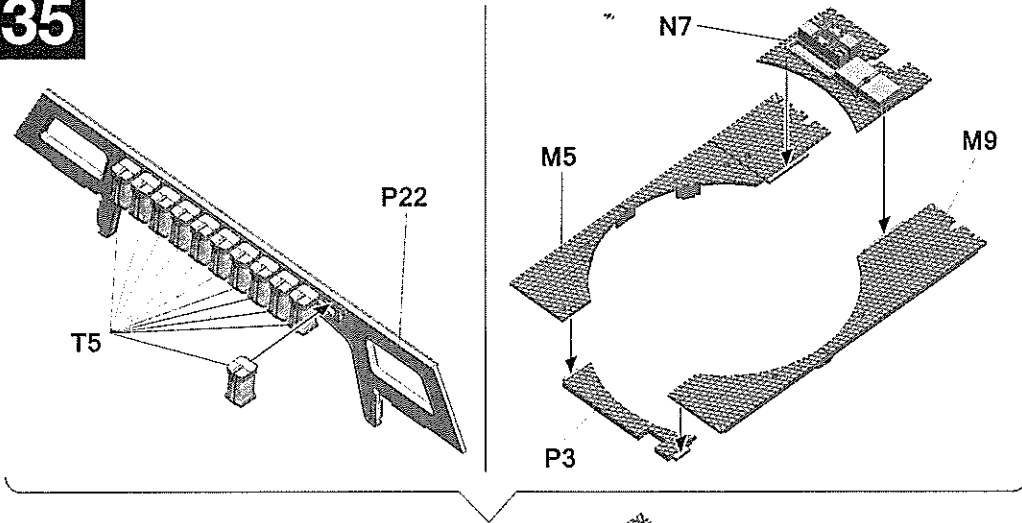

36

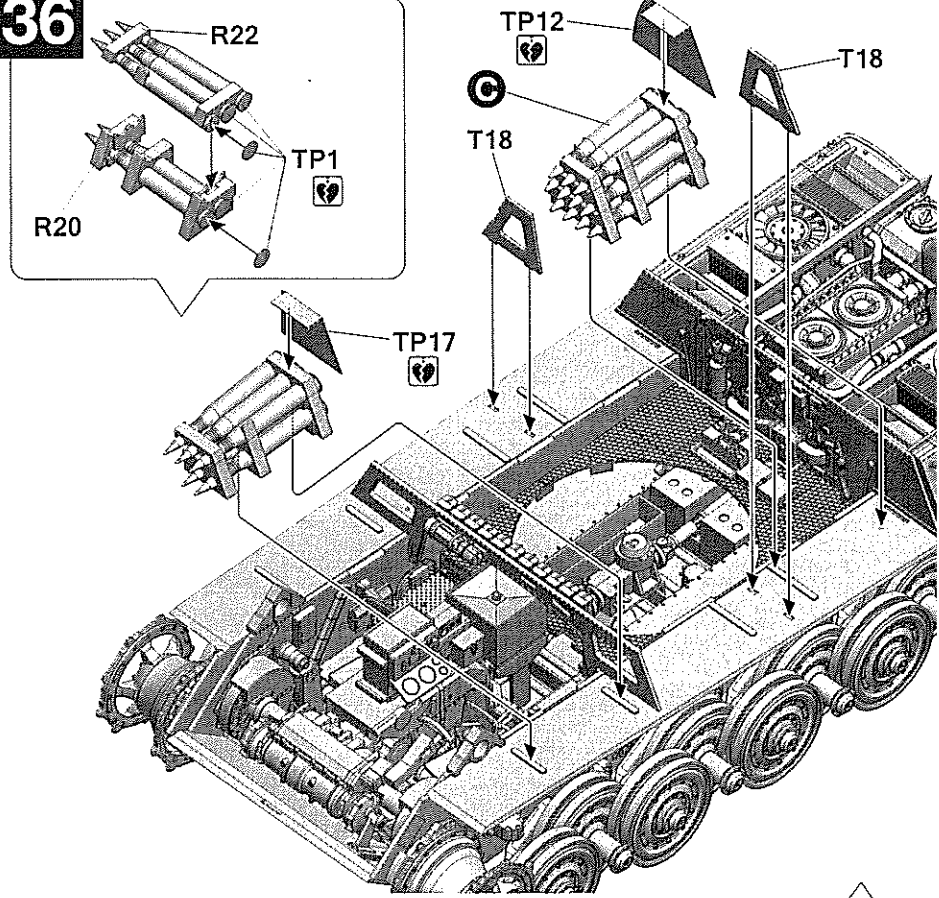

37

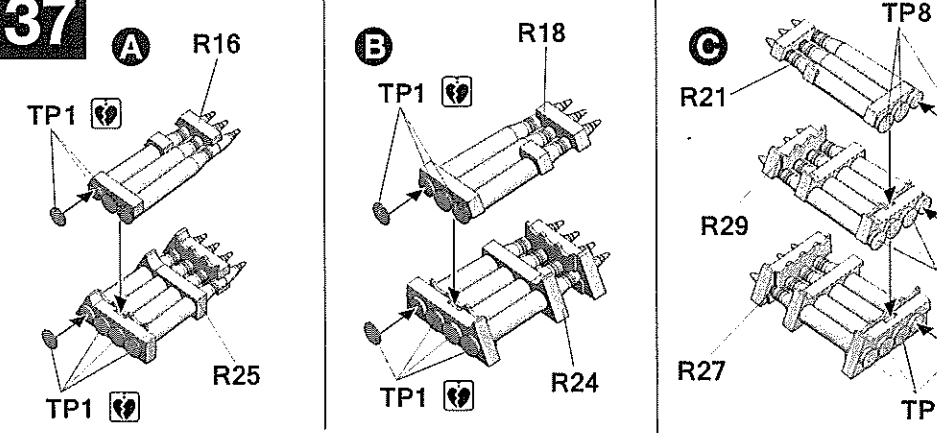

38

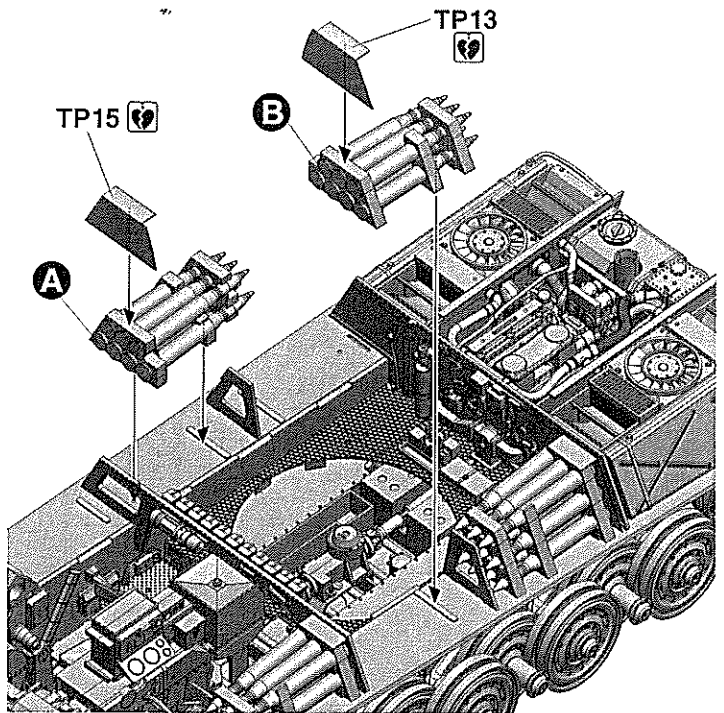
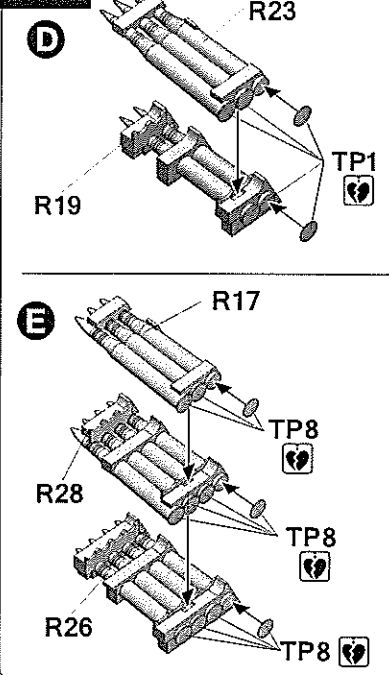

40

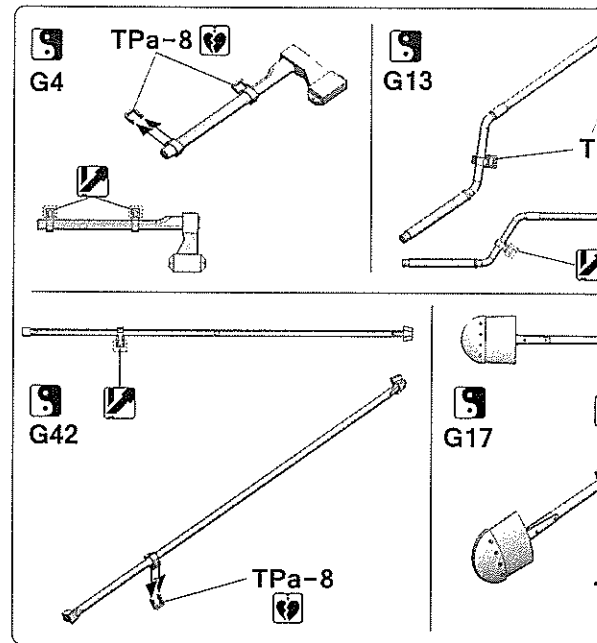

39

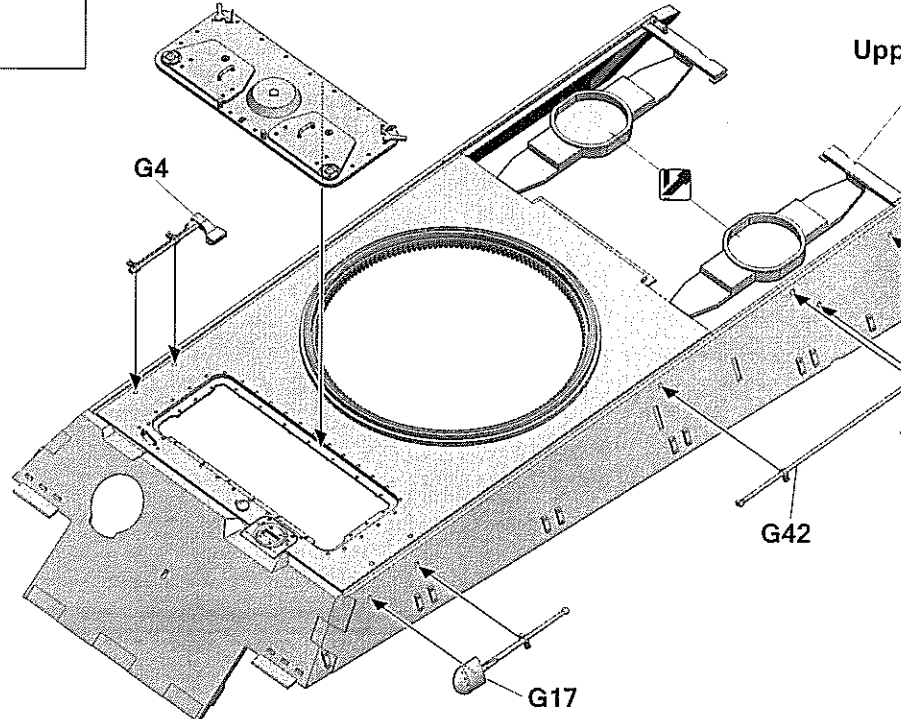
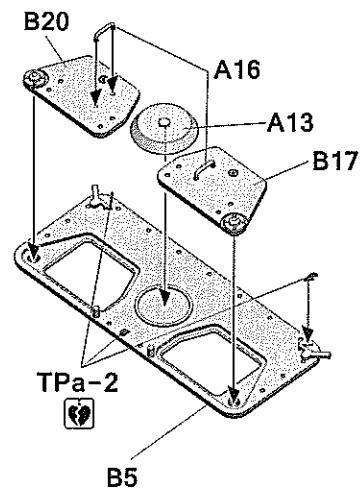
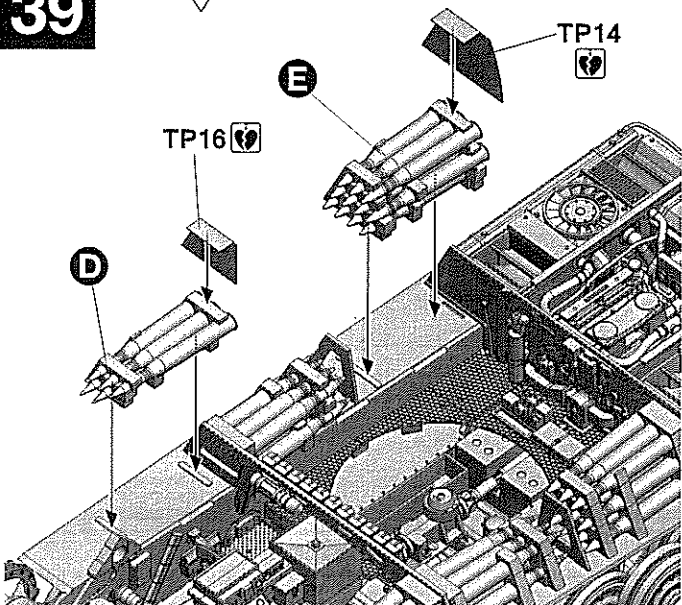

41

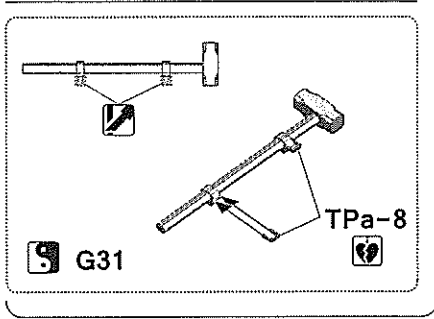
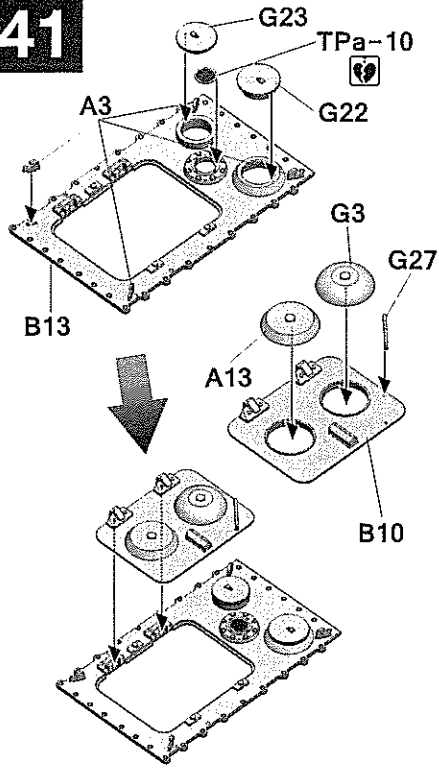

42

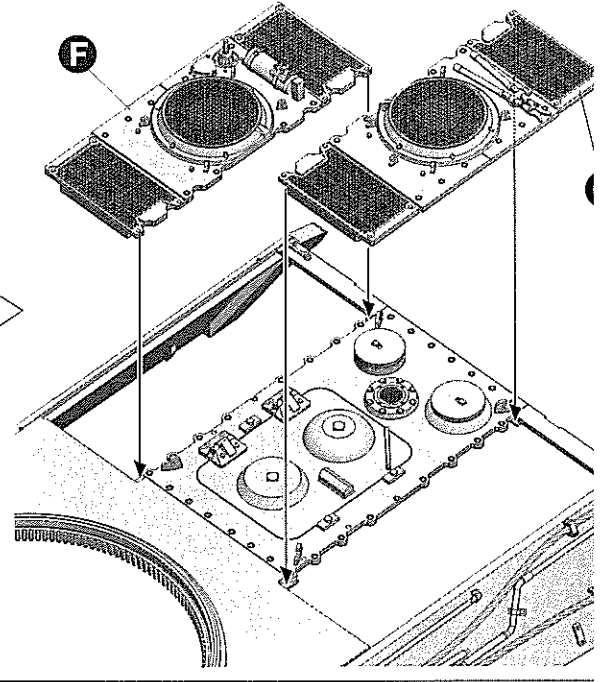
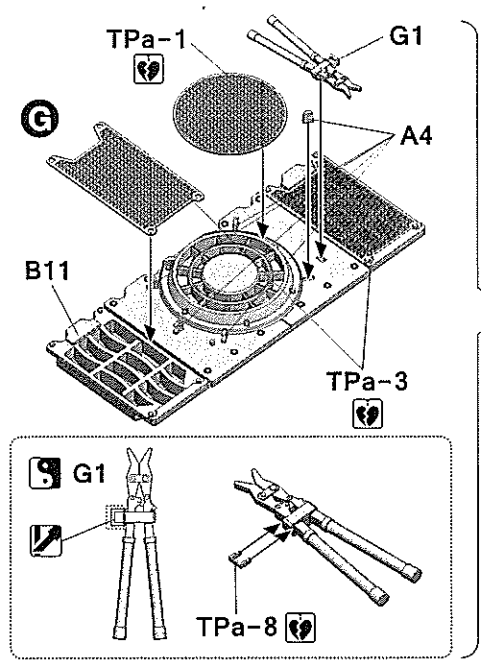
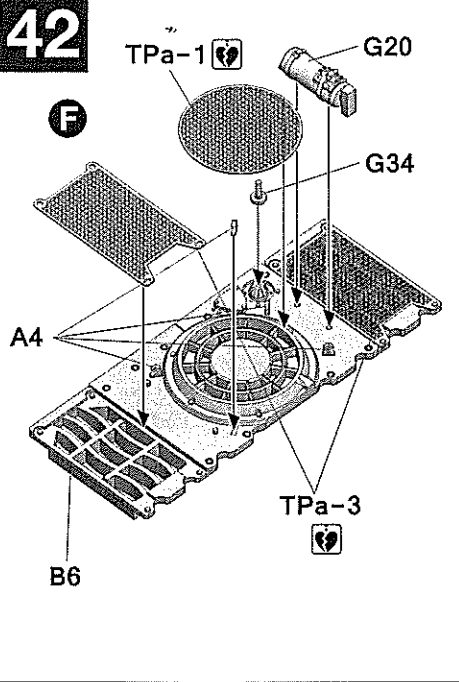

43

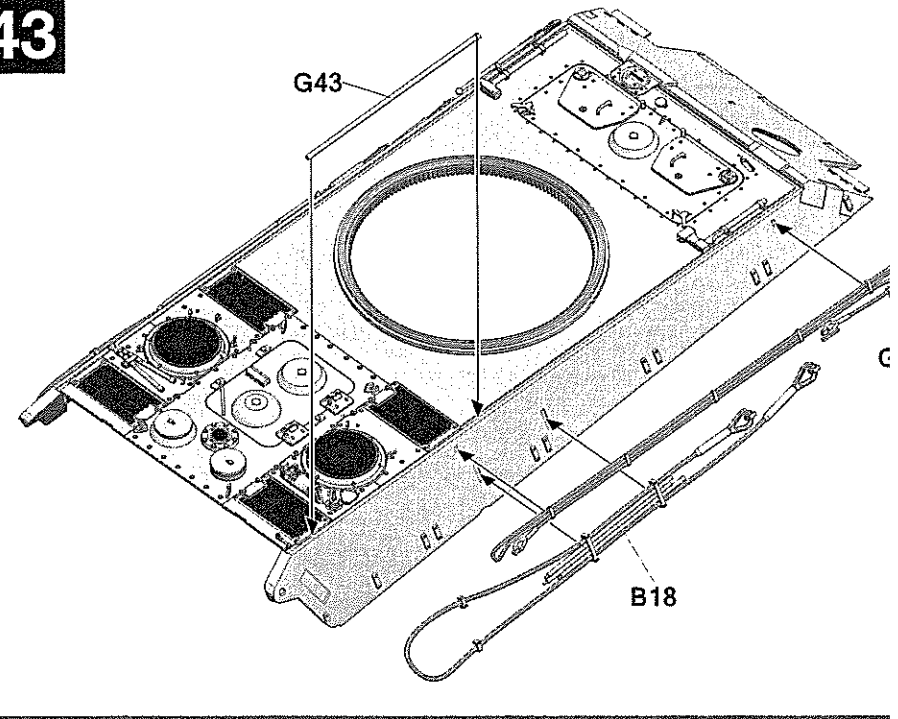
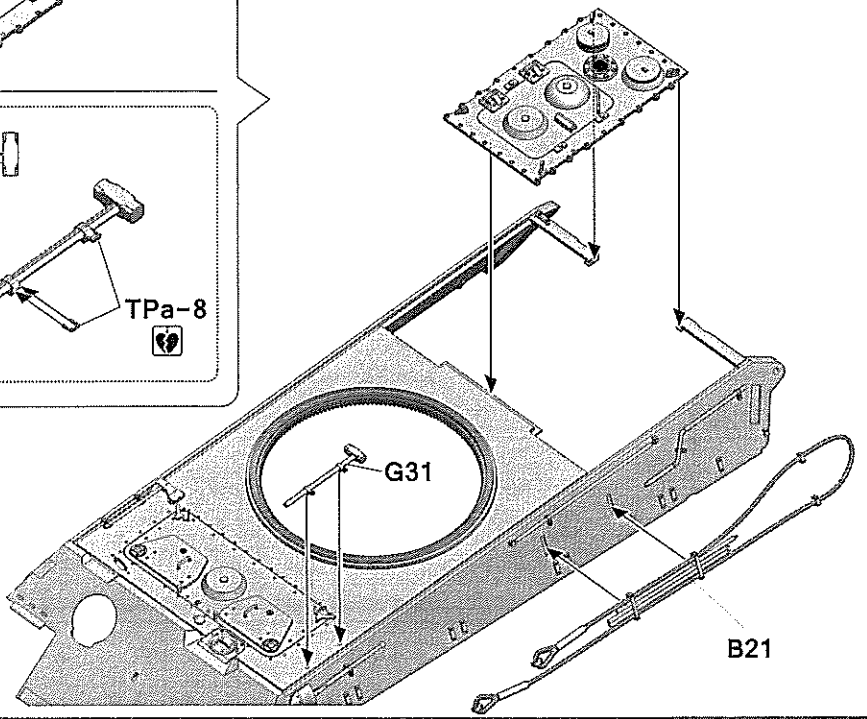

44

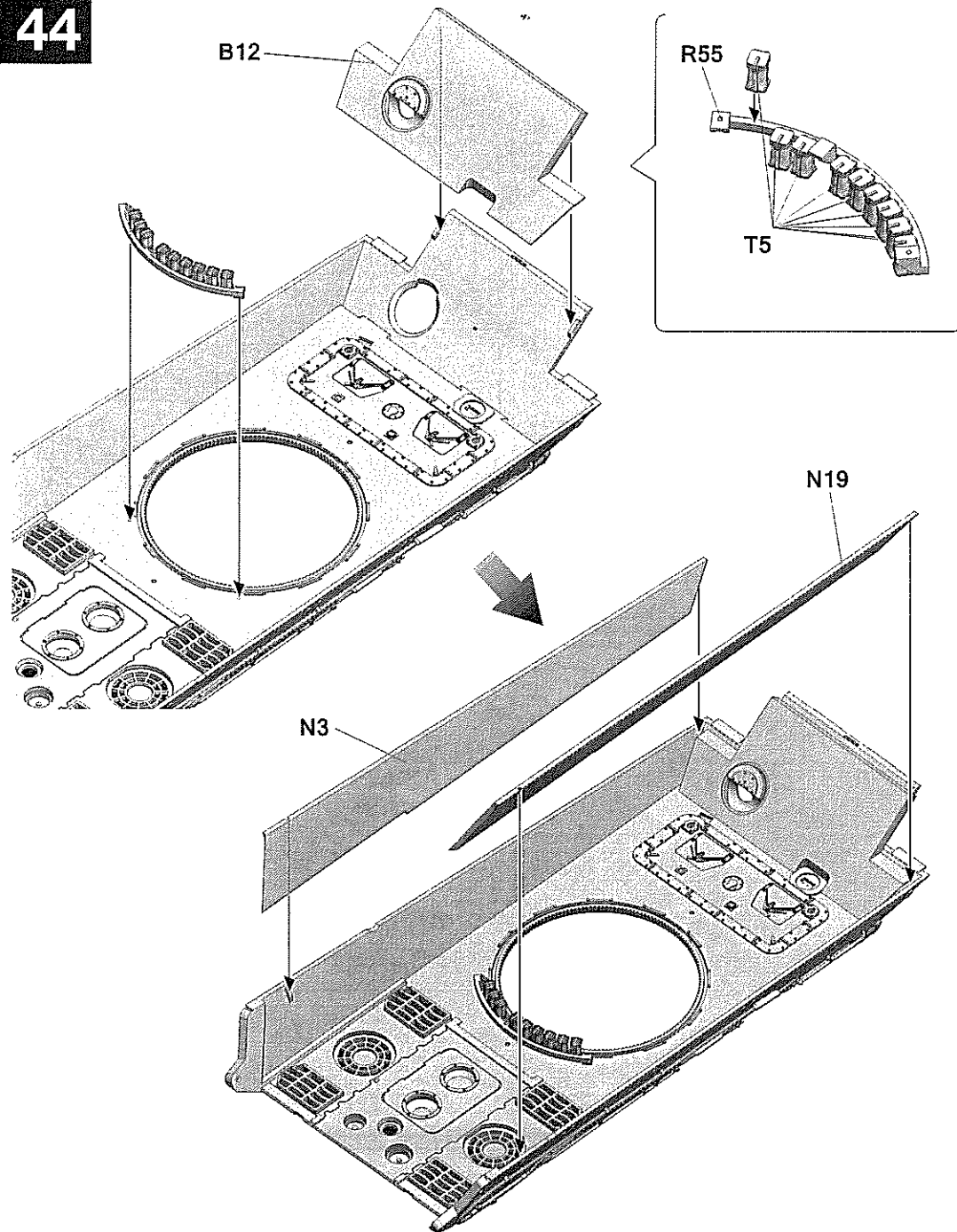

45

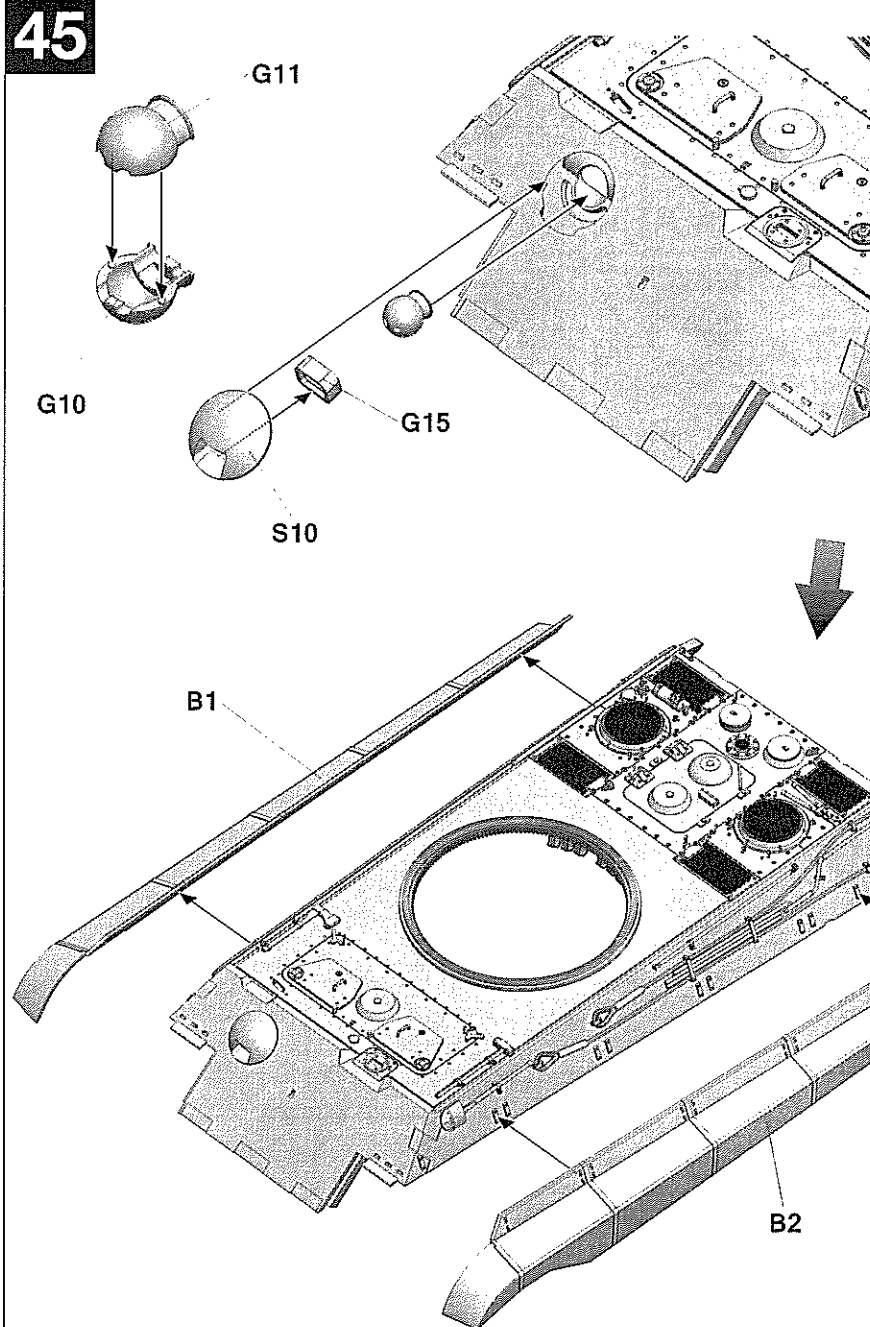

46

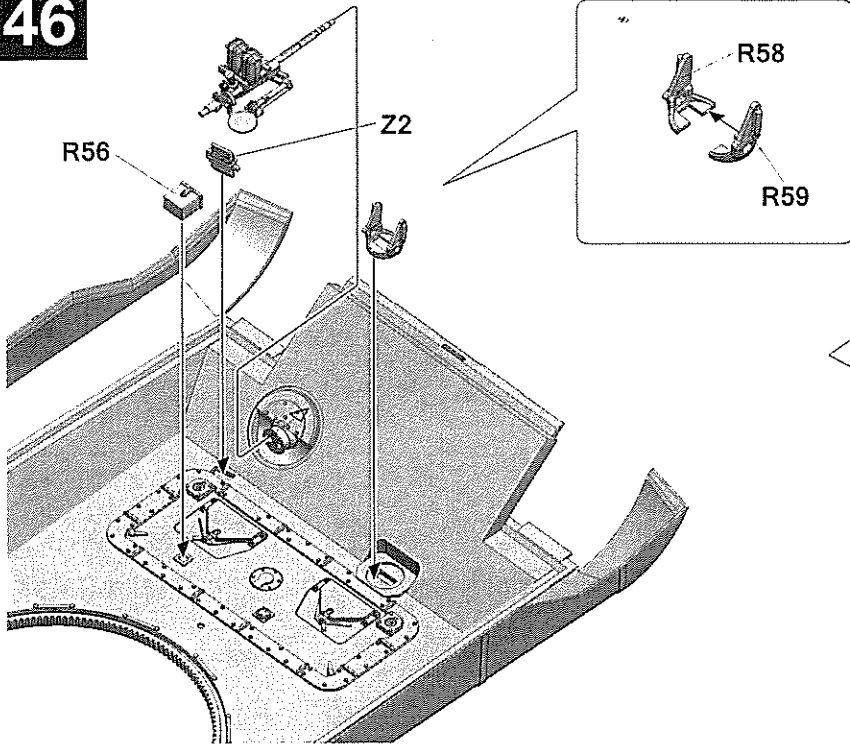

47

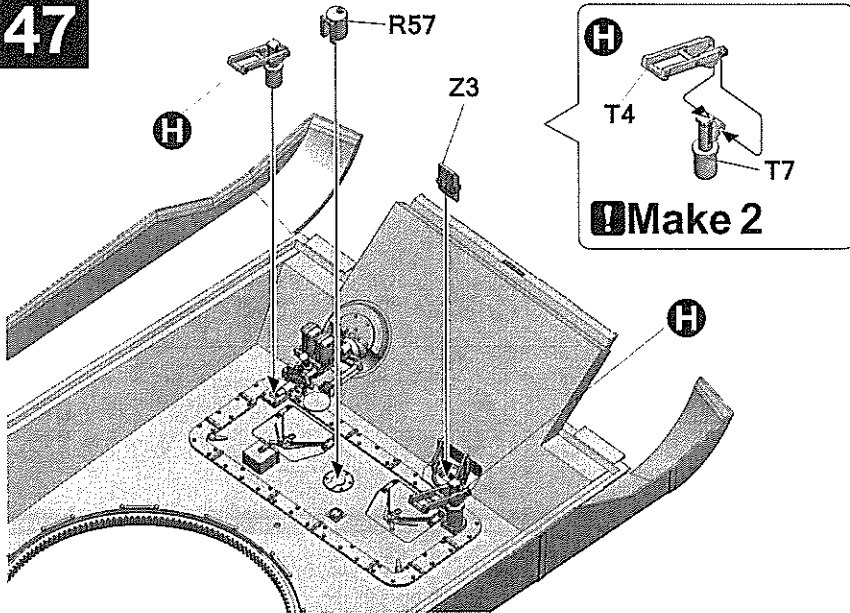

48

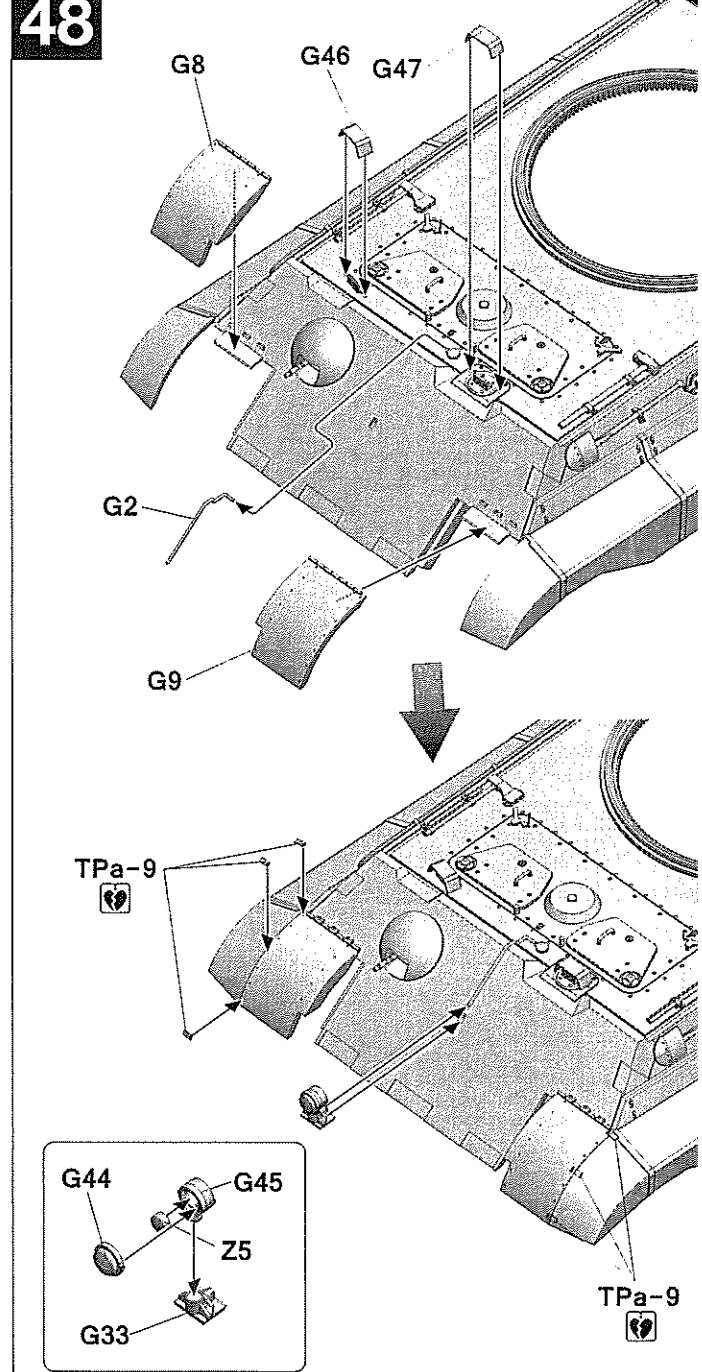
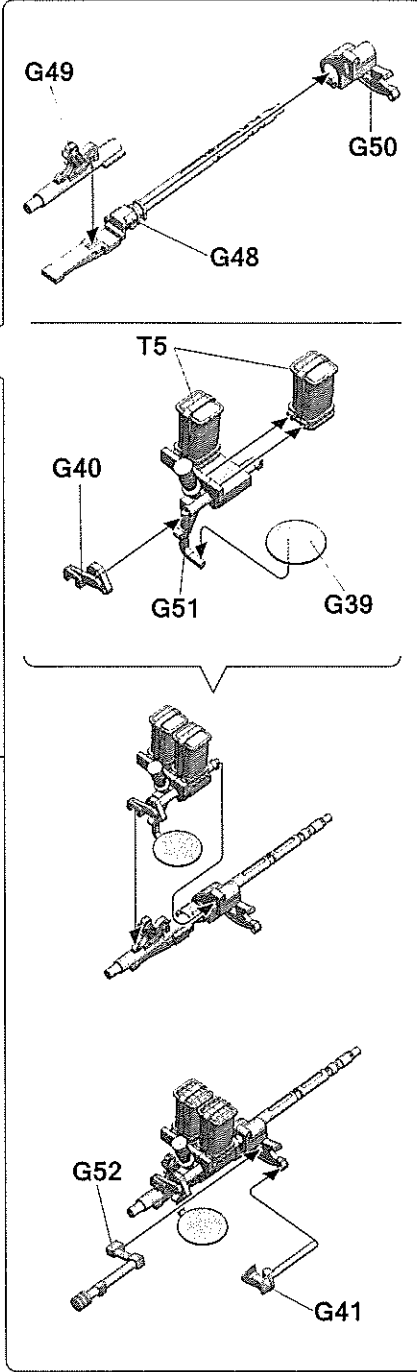

49

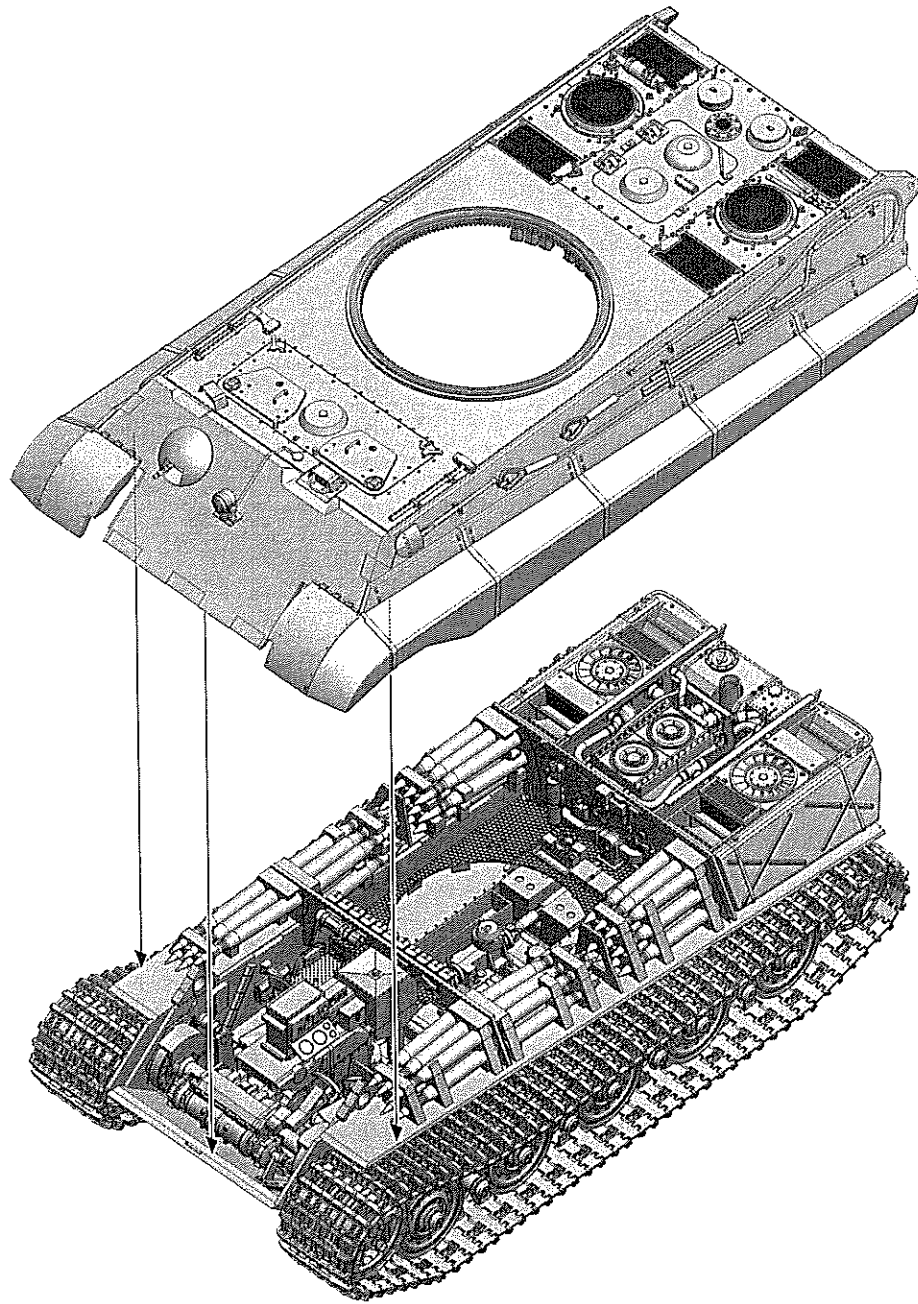

50

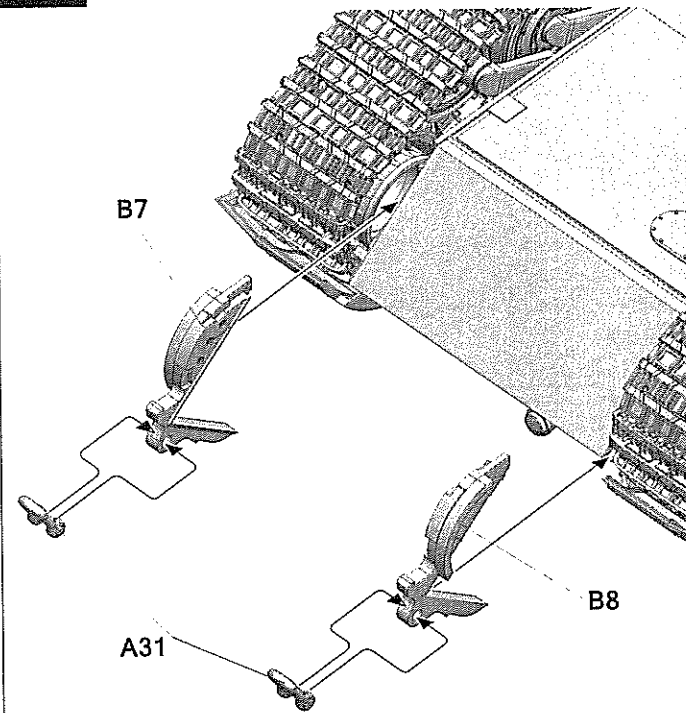

51

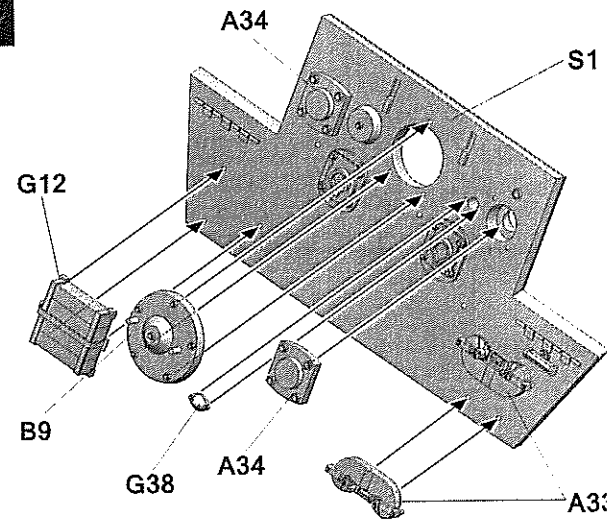

52

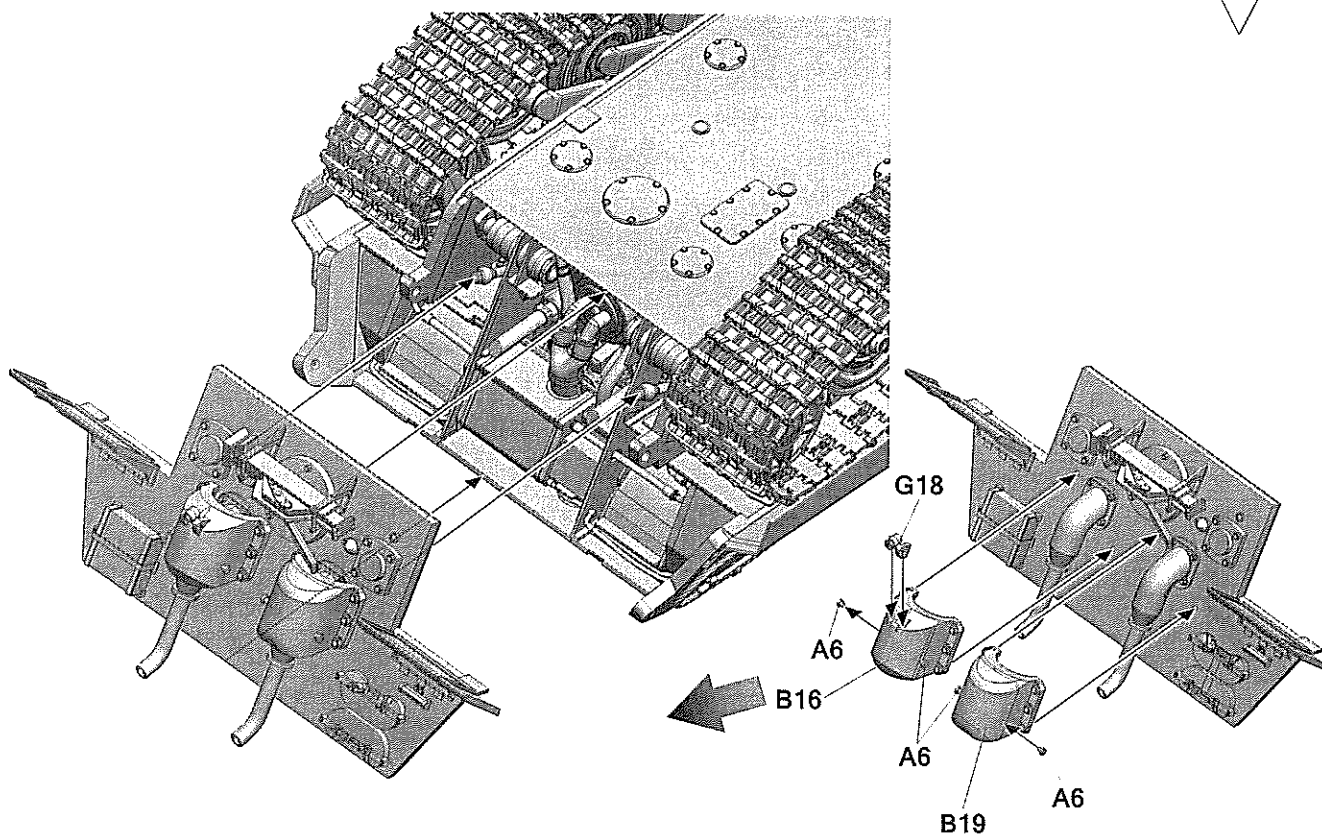
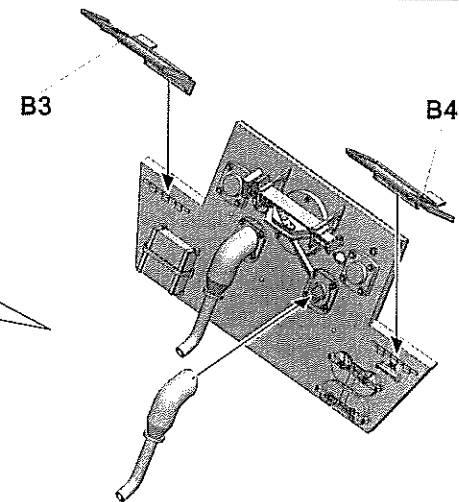
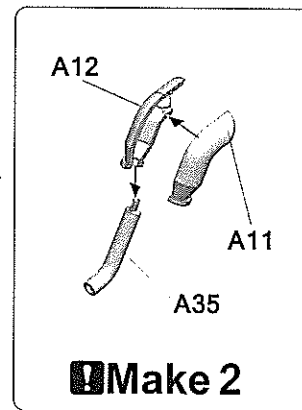
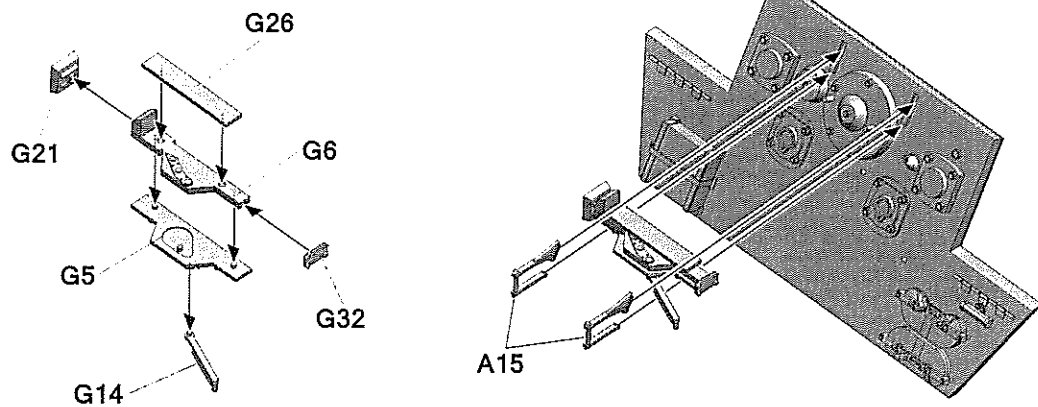

53

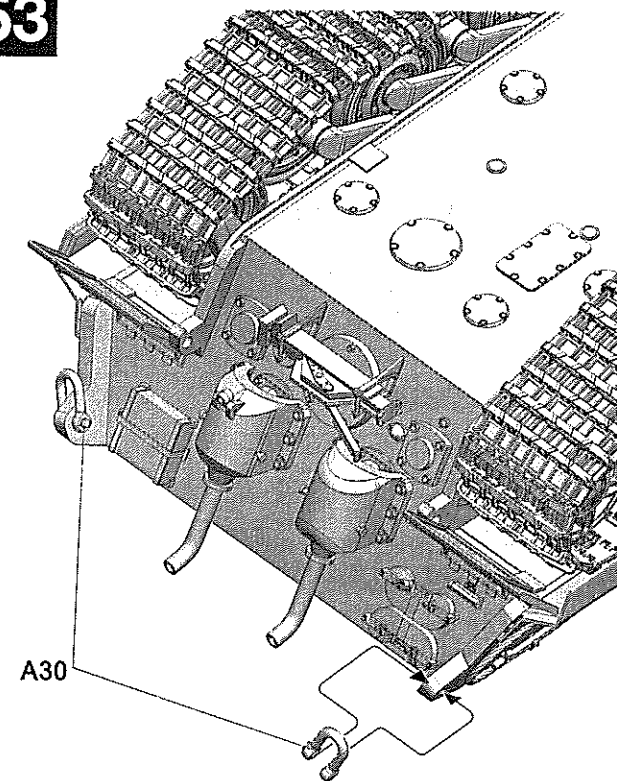

54

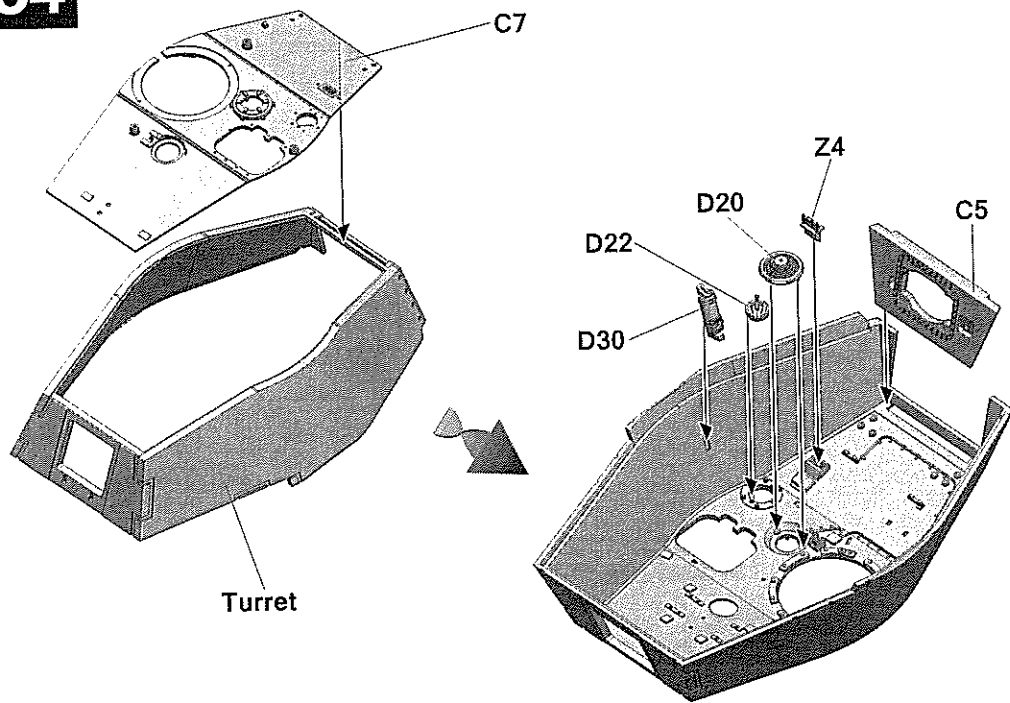

56

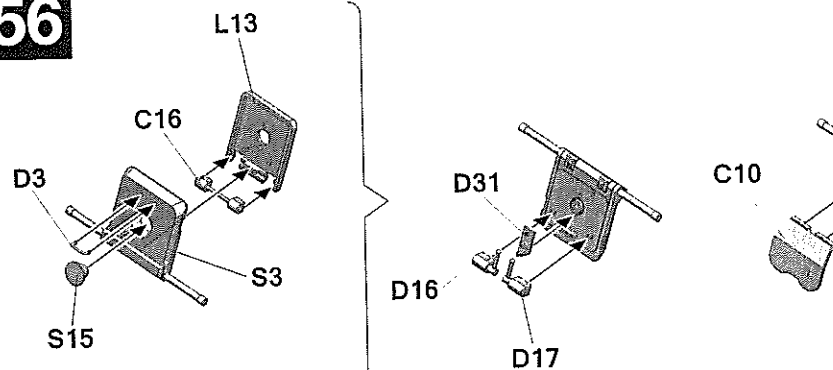

57

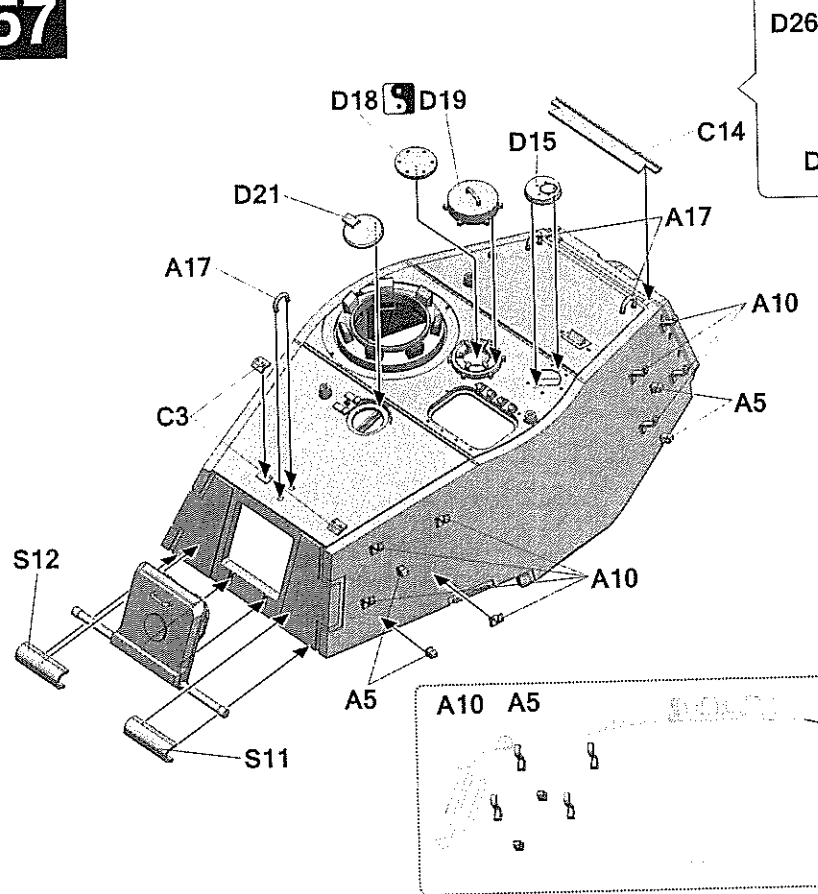

55

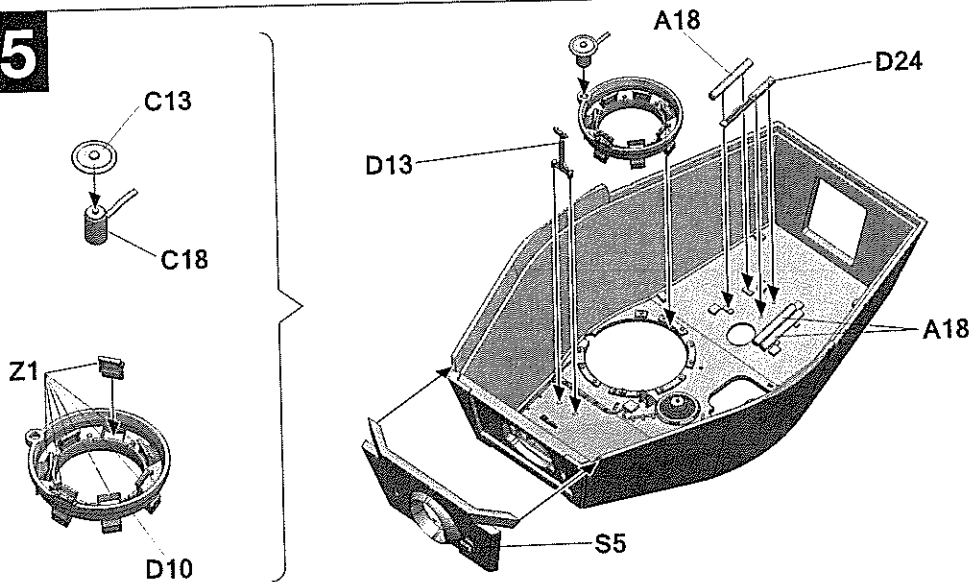

58

D23
Open

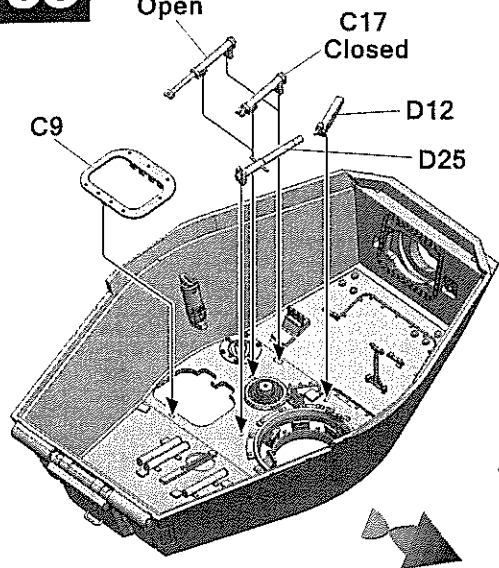

Closed

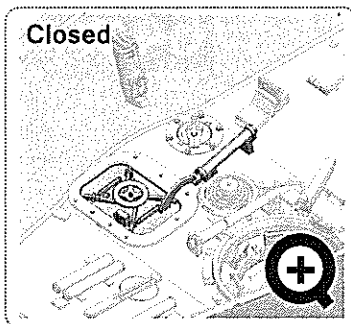

Open

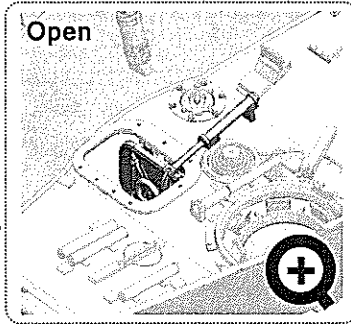

60

D27

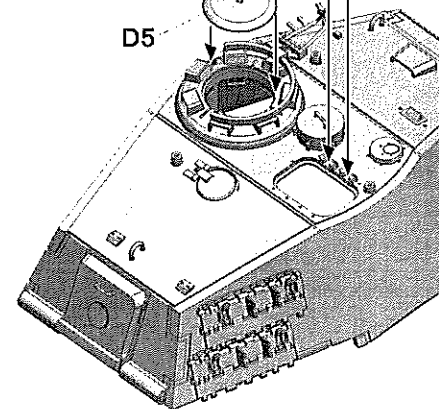
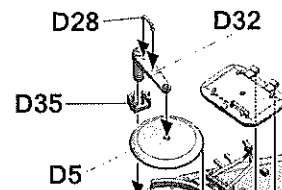
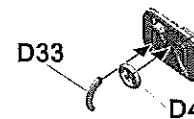
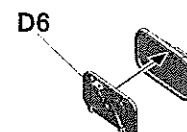
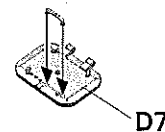

59

L23

L37

L35

A1

D1

A2

D8

D9

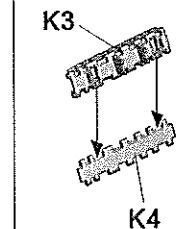
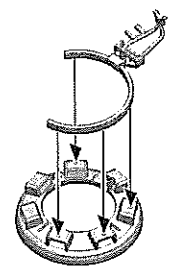

Make 4

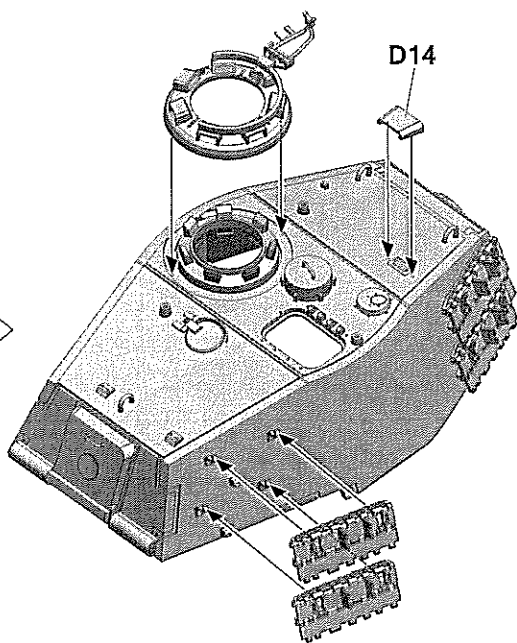

61

A10

A5

A5

A10 A5

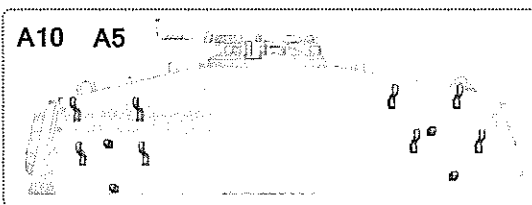

K3



Mal

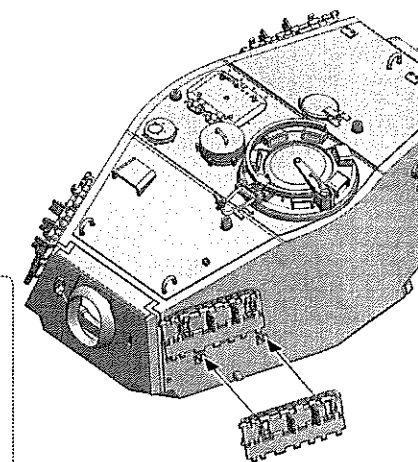

62

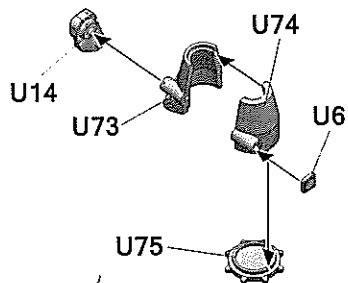
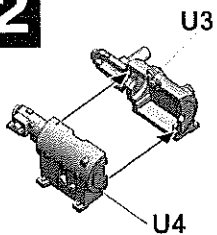

A

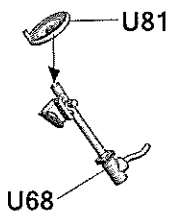
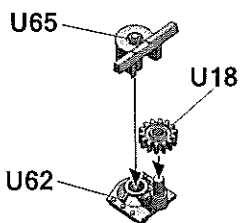
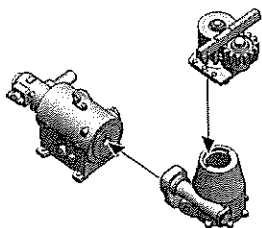

63

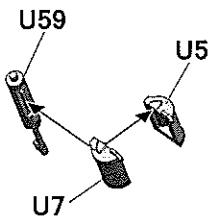
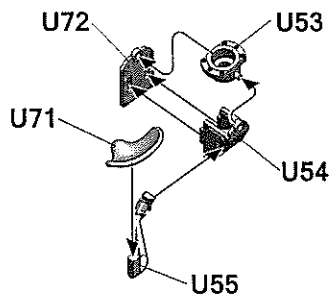
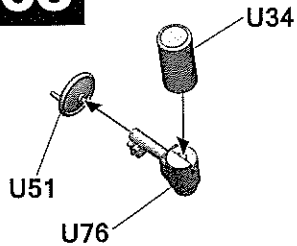

B

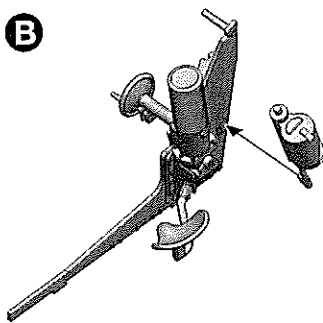
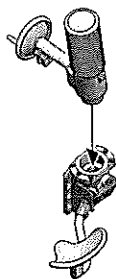
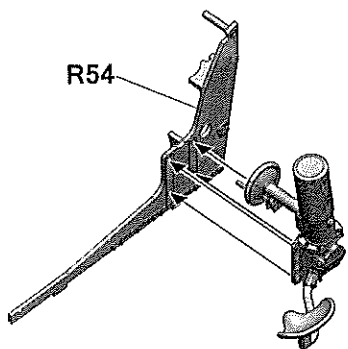

64

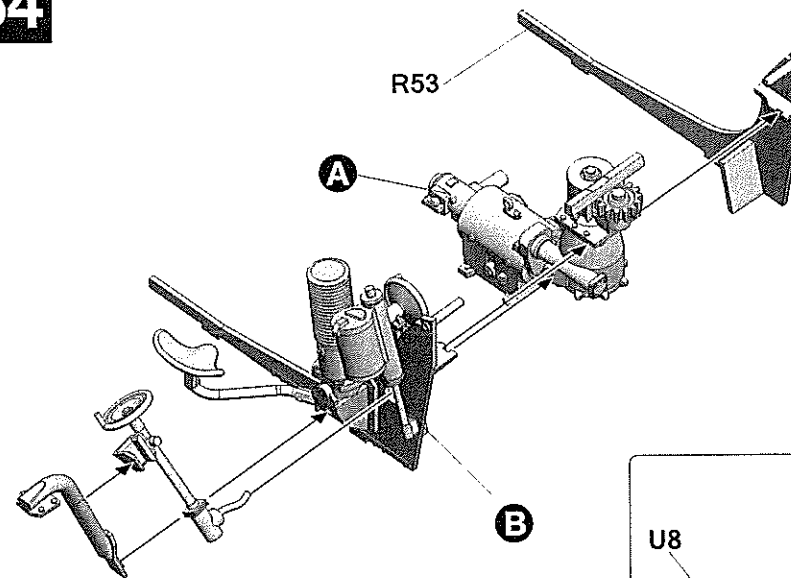

B

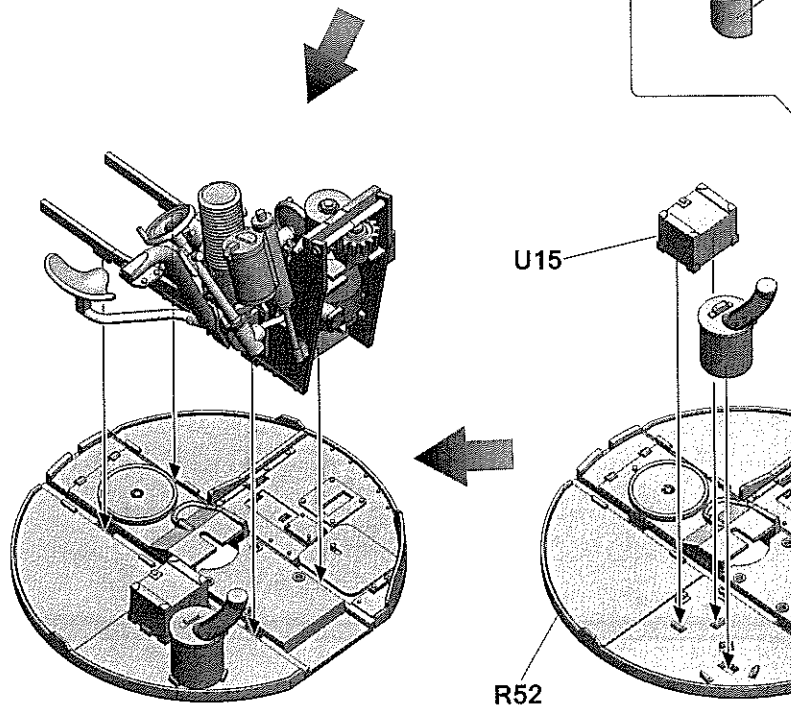

65

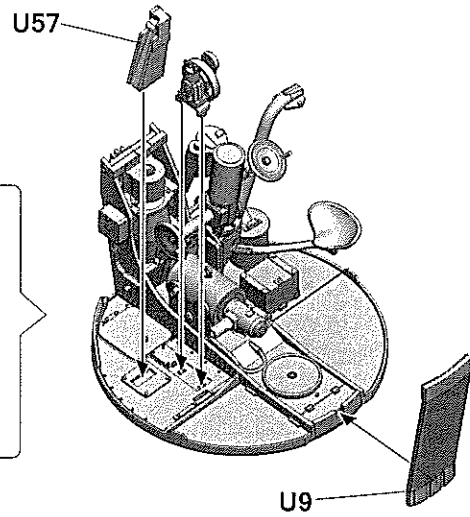

67

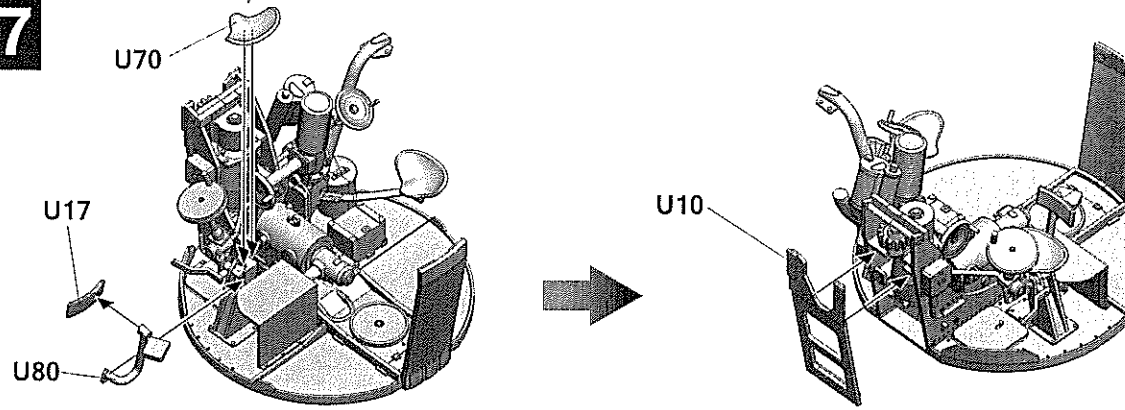

68

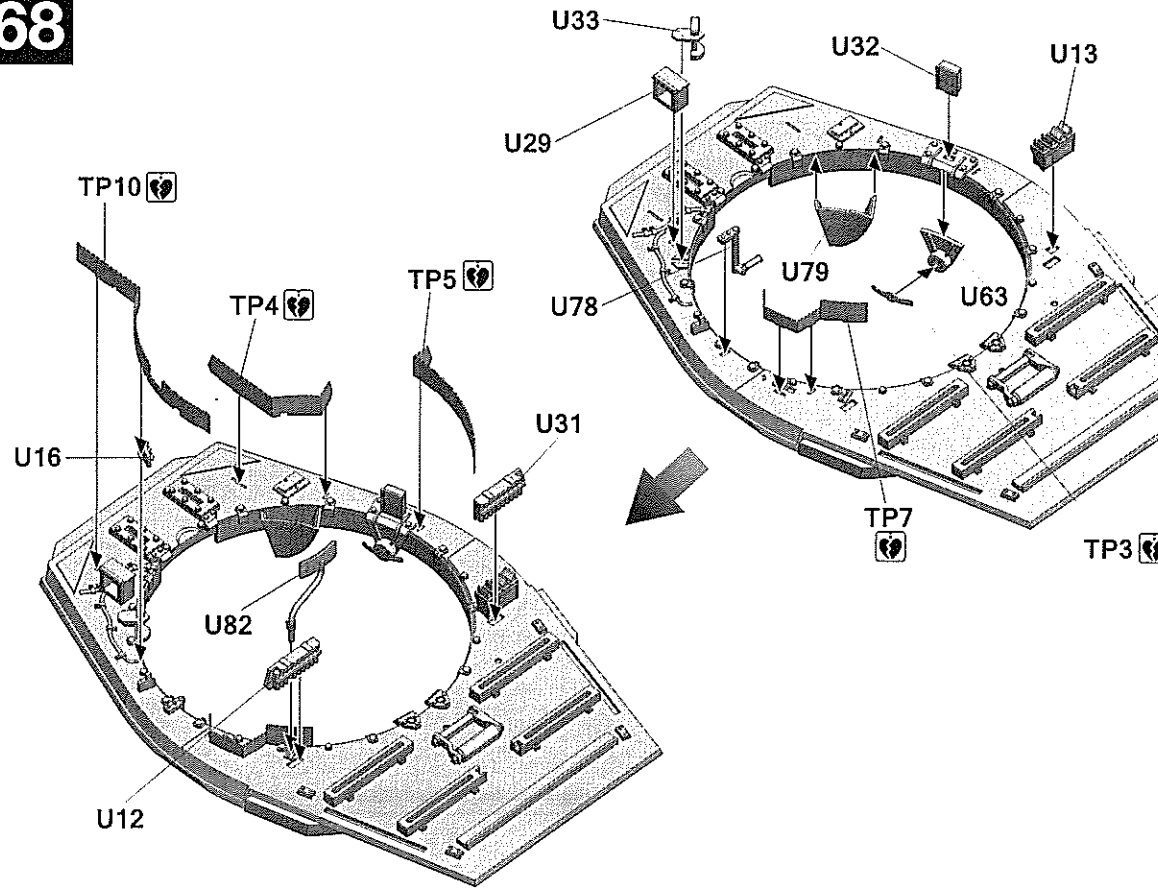

66

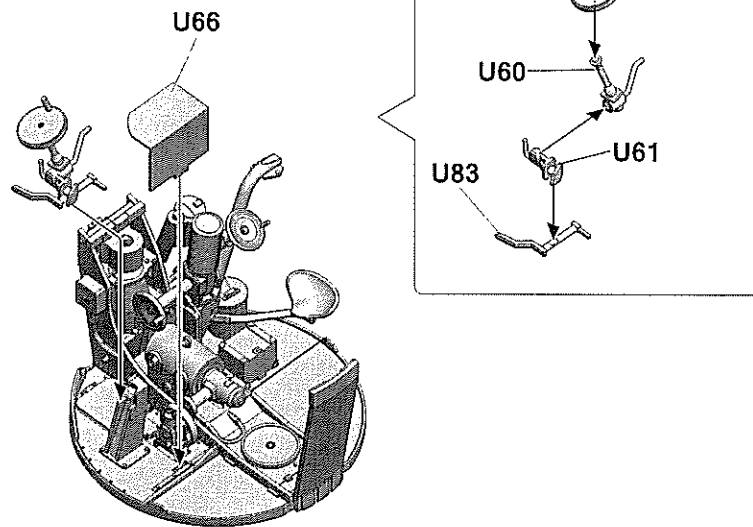

71

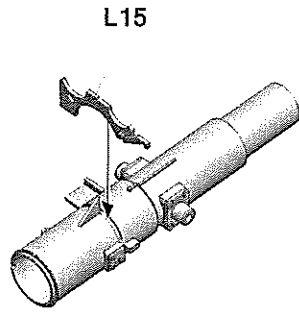
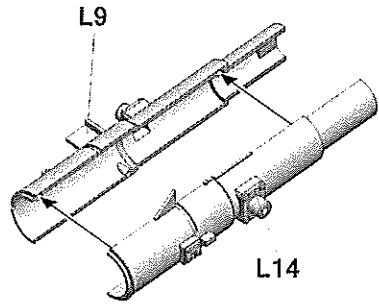

72

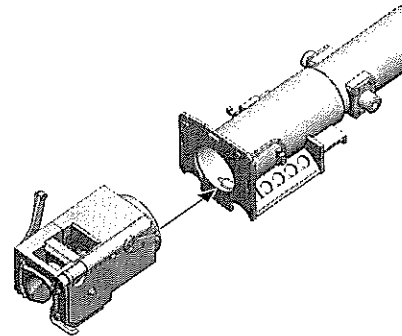
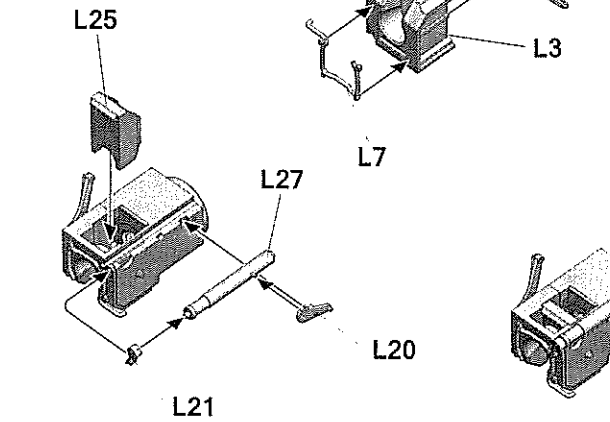
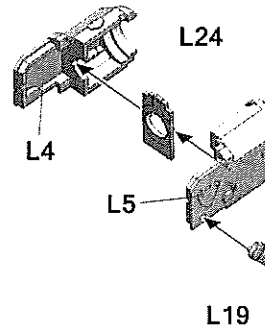
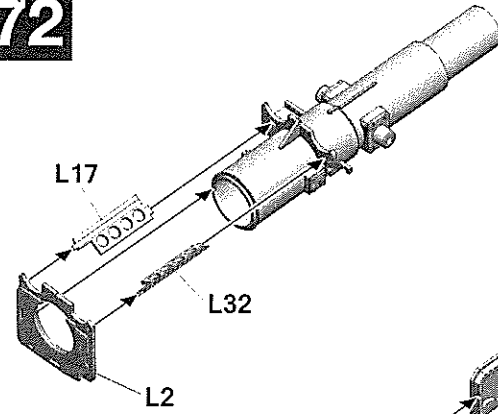

73

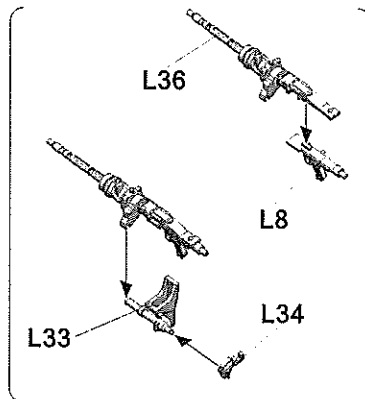
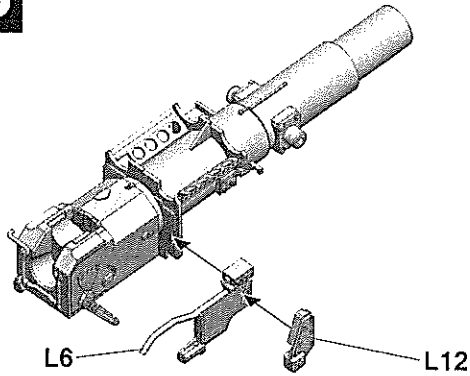

74

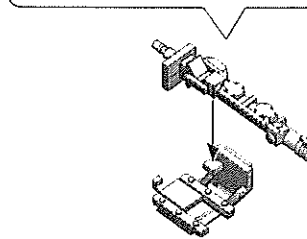
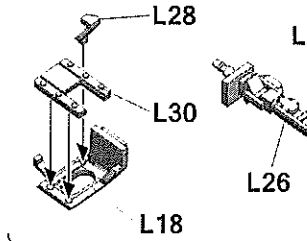
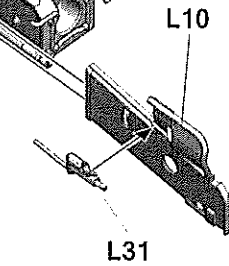
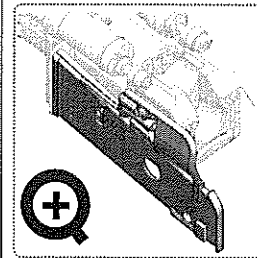
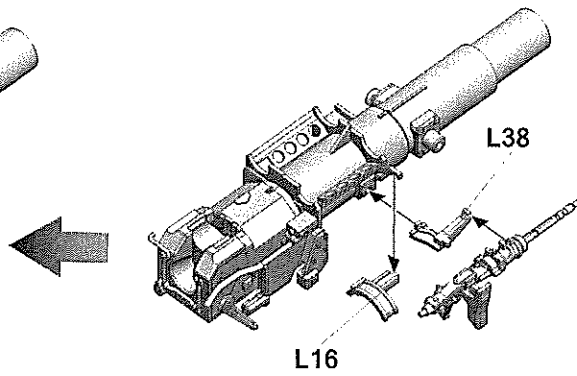
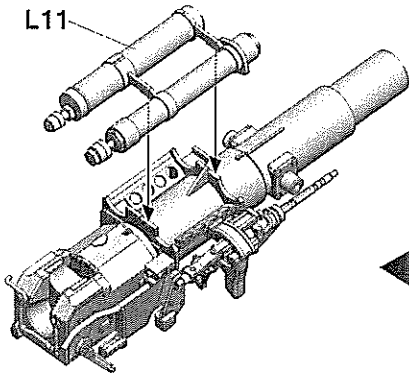

75

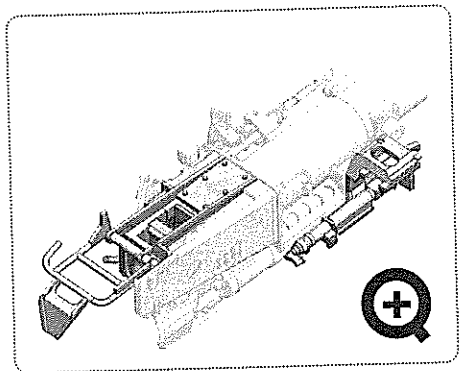
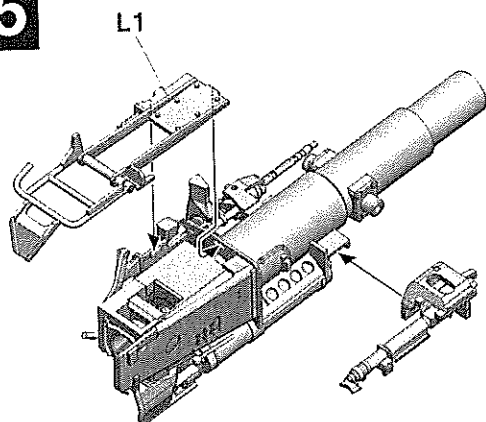

77

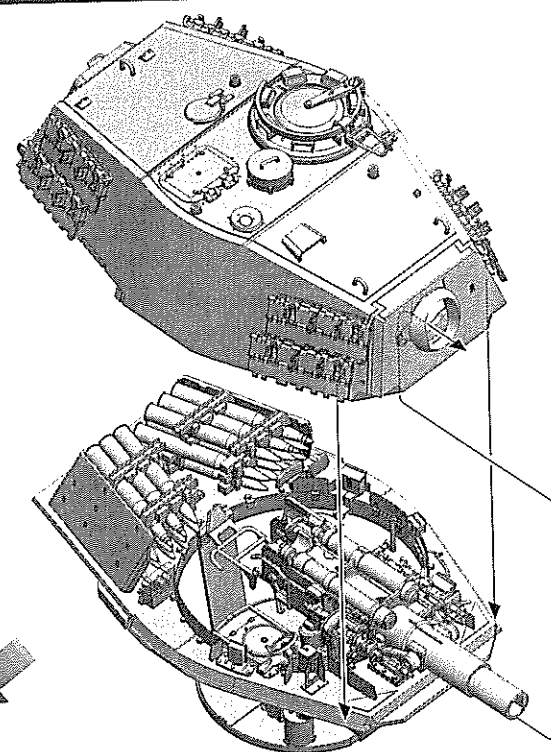

76

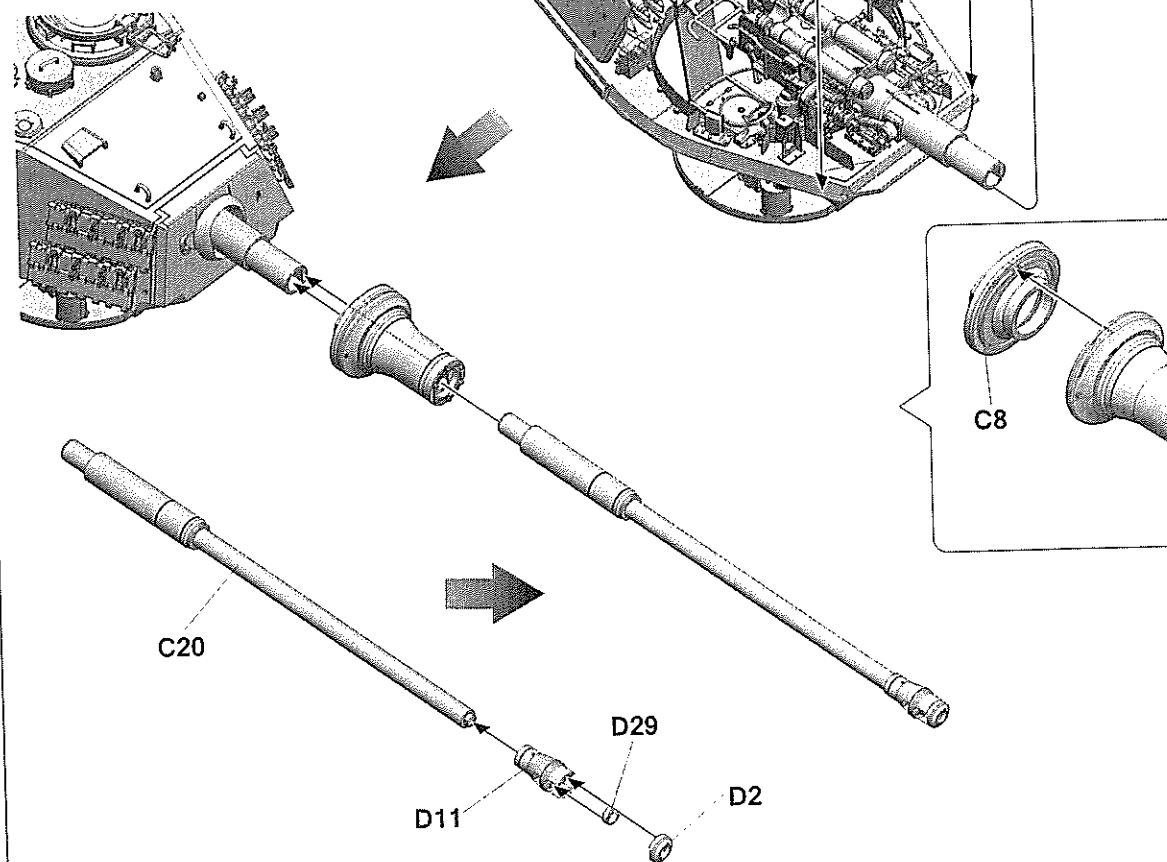
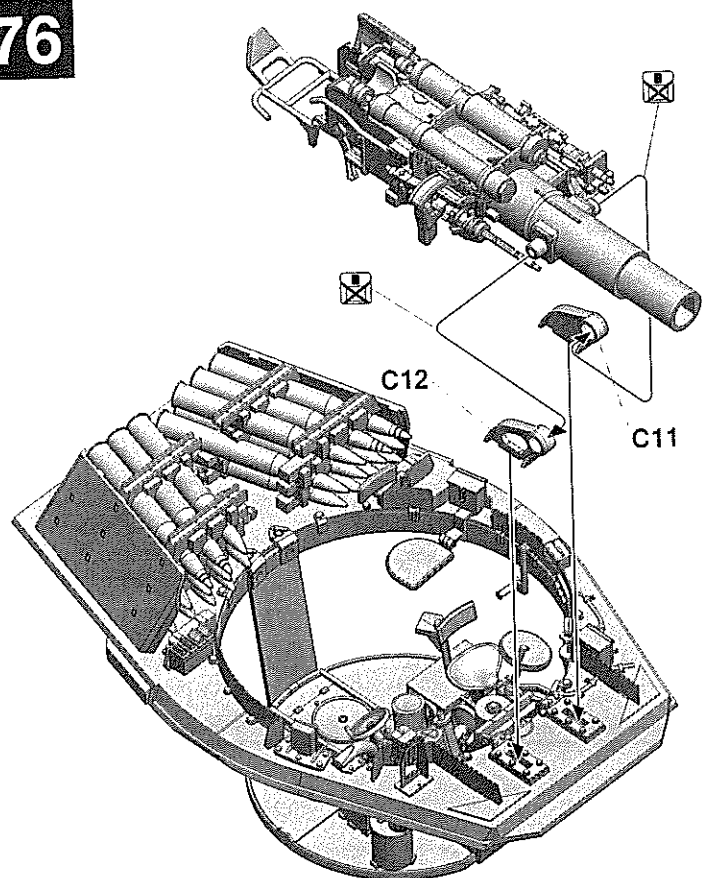

78

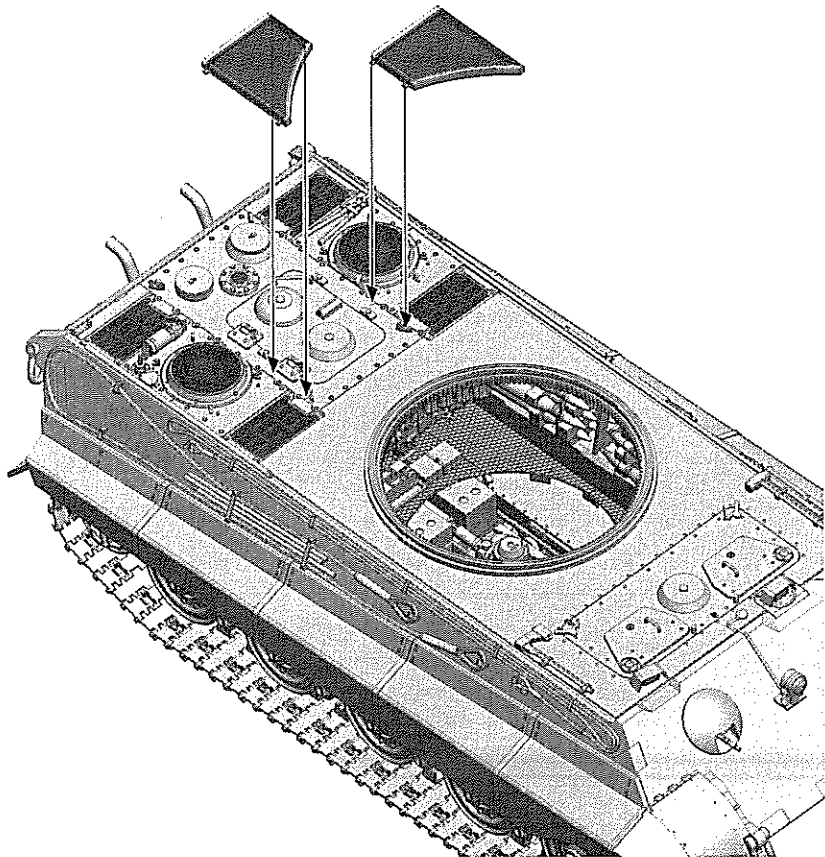
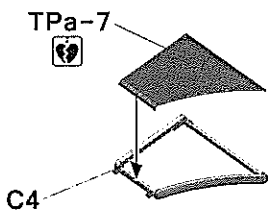

79

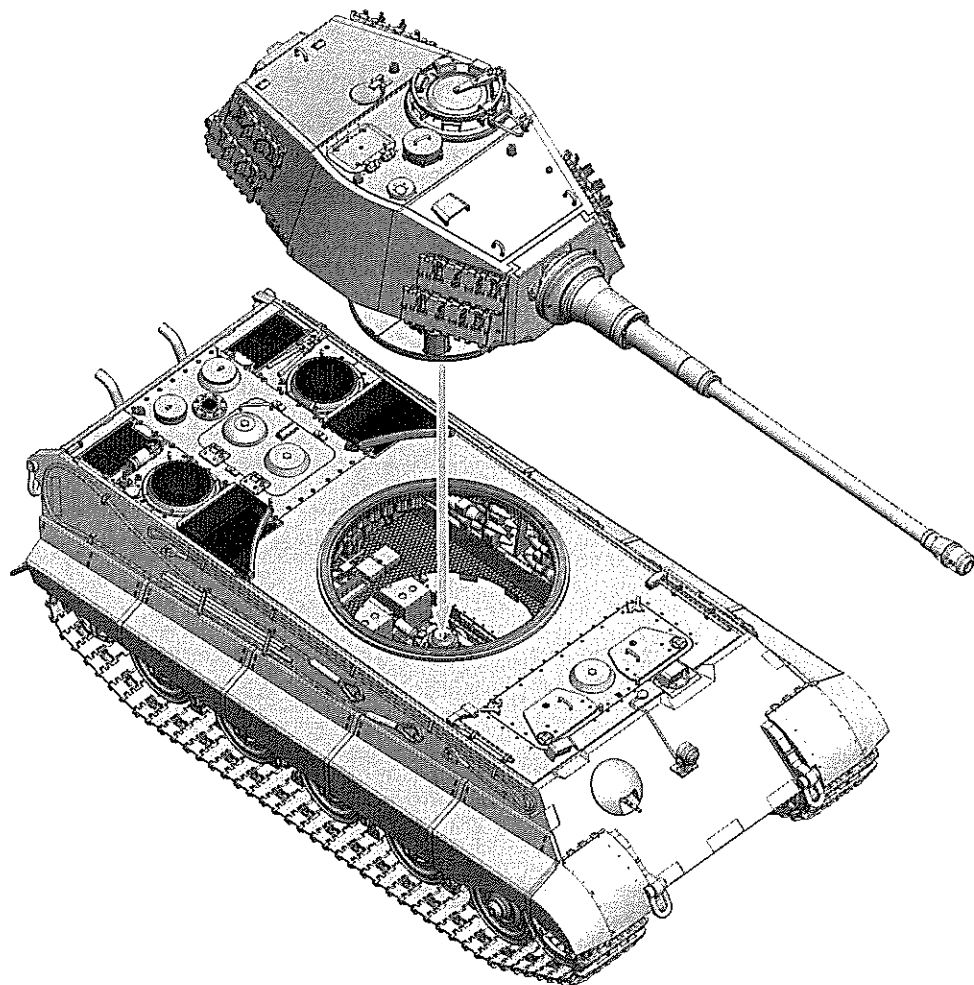
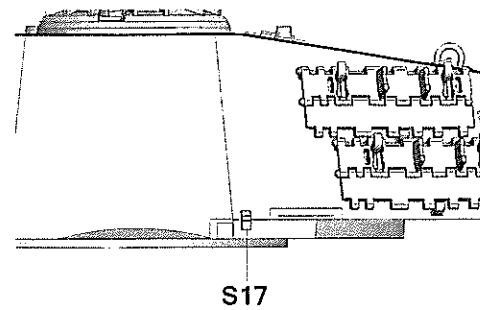
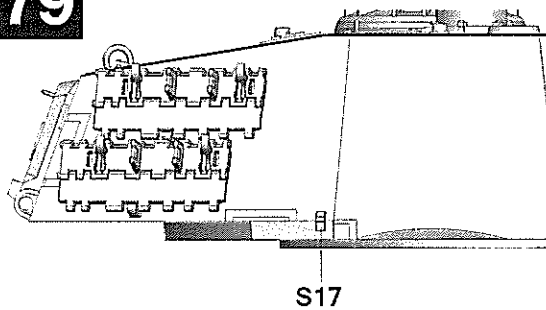

03.03.2073



KING TIGER HENSCHEL

Color info and profiles by



Painting and Marking Guide

- A.MIG 002 Olivgrün Opt. 2
- A.MIG 010 Dunkelgelb
- A.MIG 015 Schokobraun
- A.MIG 035 Dark Tracks
- A.MIG 037 New Wood
- A.MIG 042 Old Rust
- A.MIG 045 Gun Metal

The 1st Company 506th schwere Heeres Panzer Abteilung, Ardennes, December 1944.

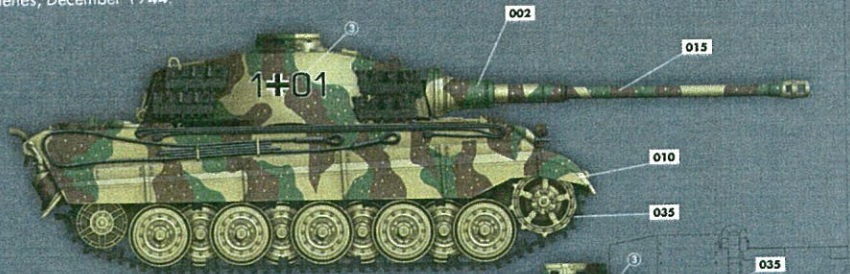

Specific colors for Takom Kits

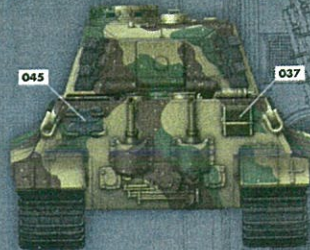
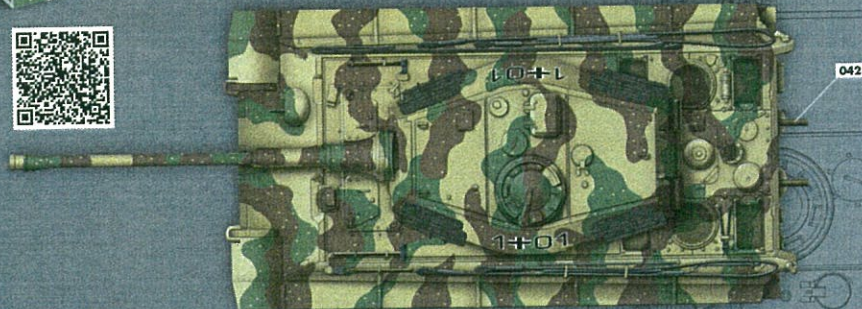

TAKOM Sd.Kfz.182 KingTiger Ref: 2073

03.03.2073



KING TIGER HENSCHEL

Color info an



Painting and Marking Guide

- A.MIG 002 Olivgrün Opt. 2
- A.MIG 010 Dunkelgelb
- A.MIG 015 Schokobraun
- A.MIG 035 Dark Tracks
- A.MIG 037 New Wood
- A.MIG 042 Old Rust
- A.MIG 045 Gun Metal

The 1st Company 501st SS-Schwere Heeres Panzer Abteilung, Ardennes, December 1944.

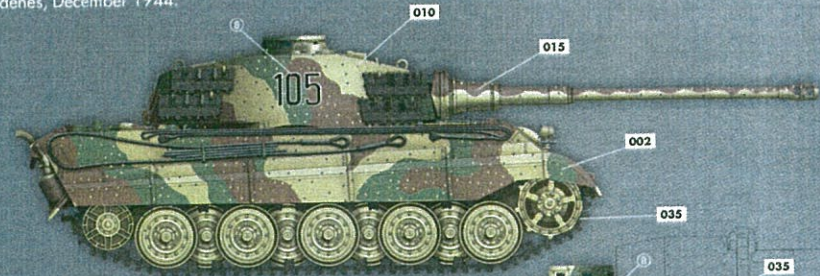

Specific colors for Takom Kits

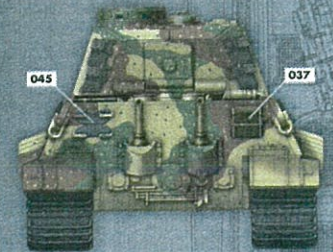
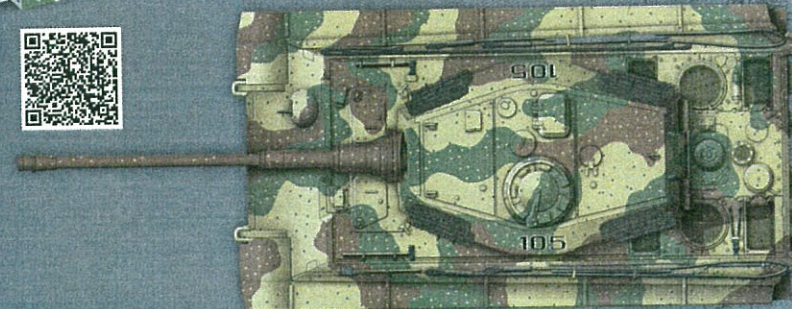

TAKOM Sd.Kfz.182 KingTiger Ref: 2073

03.03.2073



KING TIGER HENSCHEL

Color info and profiles by



Painting and Marking Guide

- A.MIG 002 Olivgrün Opt.2
- A.MIG 010 Dunkelgelb
- A.MIG 015 Schokobraun
- A.MIG 035 Dark Tracks
- A.MIG 037 New Wood
- A.MIG 042 Old Rust
- A.MIG 045 Gun Metal

2nd Company 501st.
schwere SS-Panzer Abteilung,
Ardennes, December 1944.

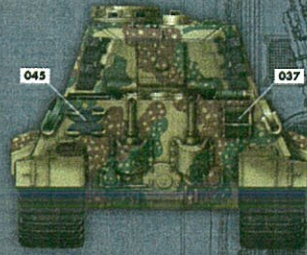

TAKOM Sd.Kfz. 182 KingTiger Ref: 2073



V2 ROCKET HANOMAG SS100 MEHLERWAGON

WWII GERMAN V-2
ROCKETTRANSPORTER/ERECTOR



King Tiger

Interior painting instruction

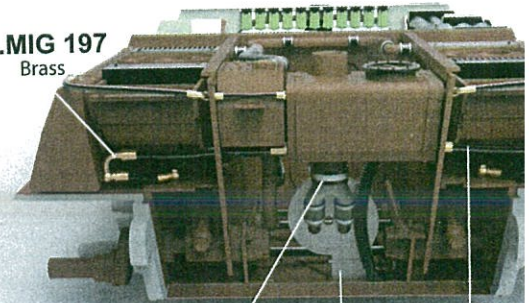
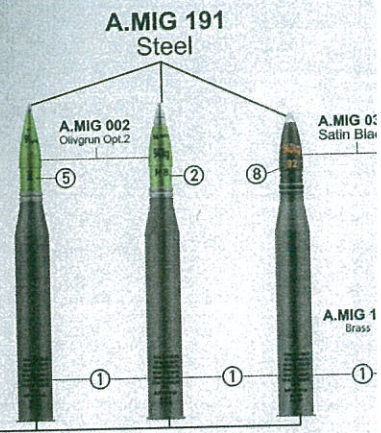
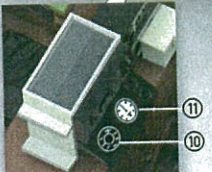
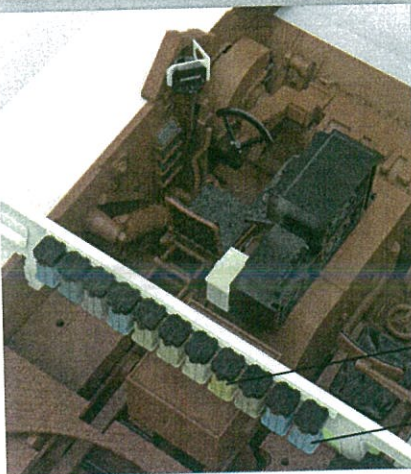
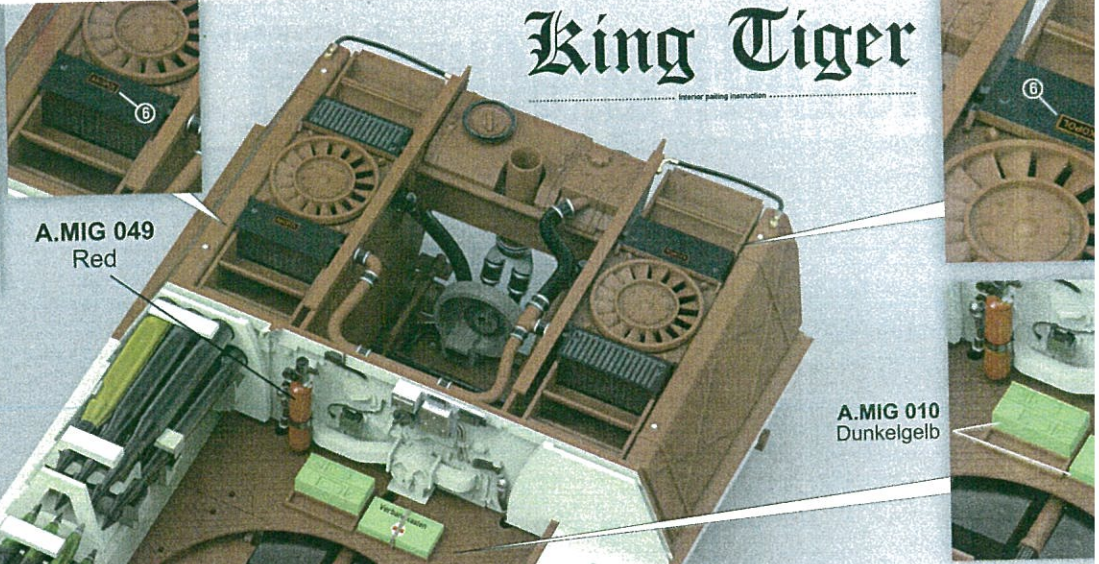
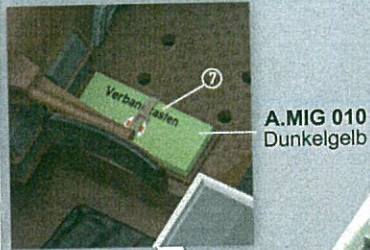
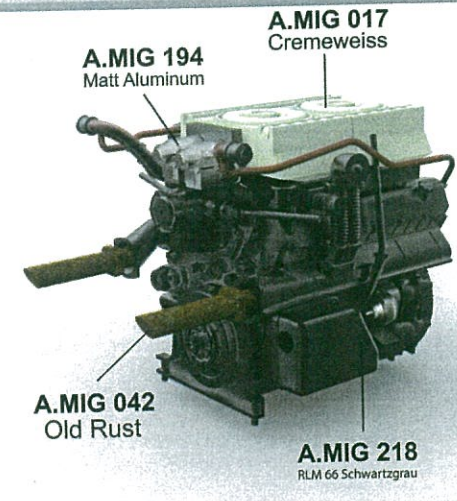

03.03.2045

Henschel Turret

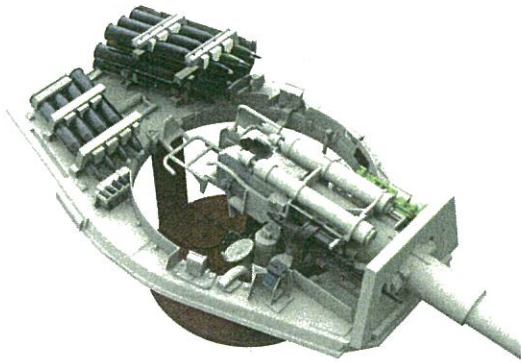

King Tiger

Interior painting instruction

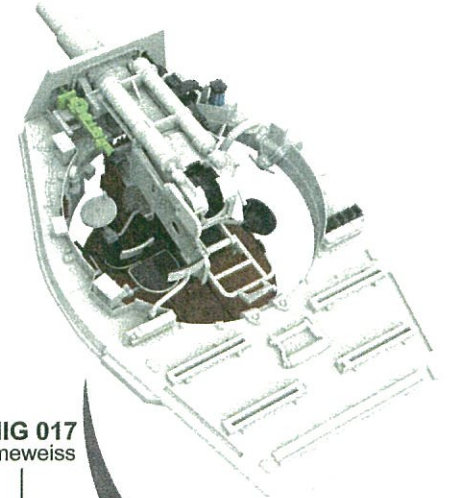

Henschel Turret

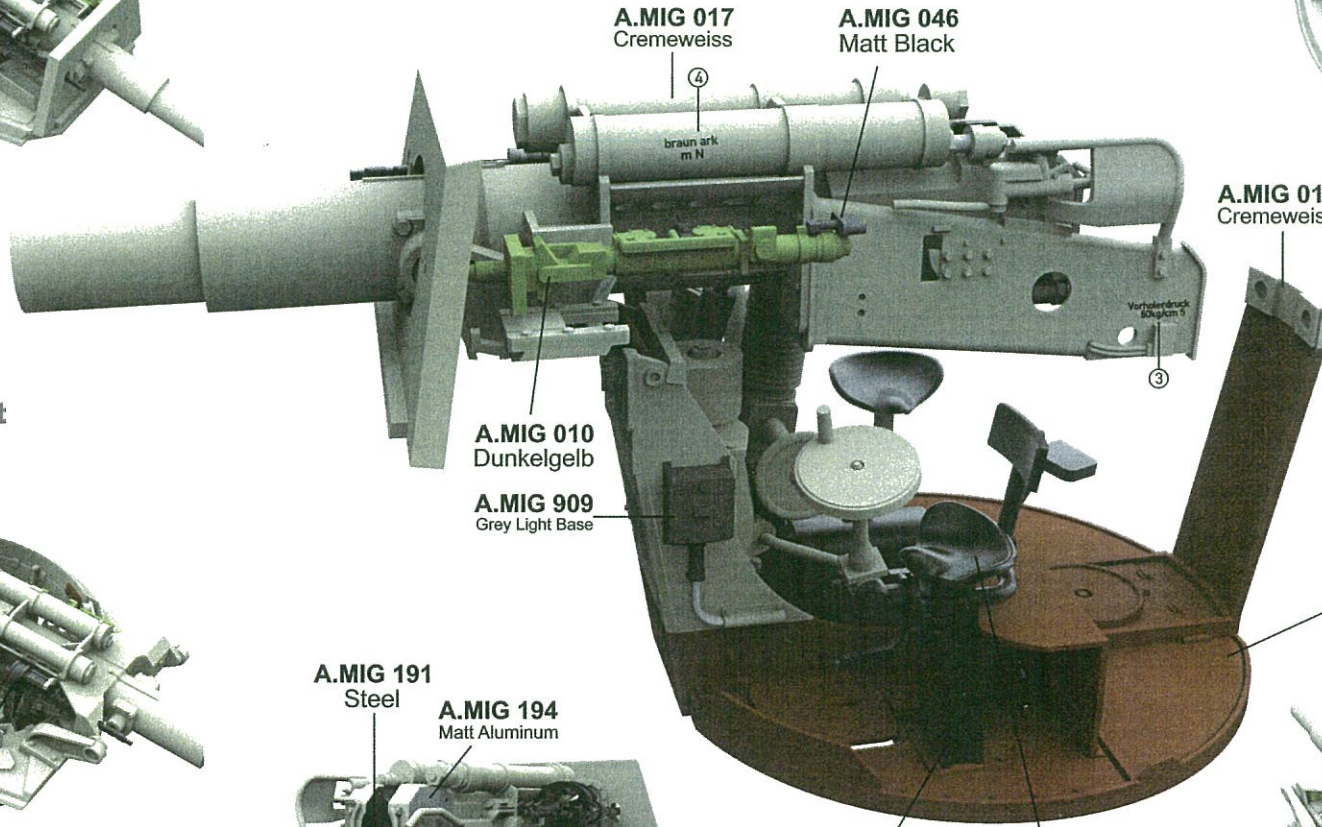
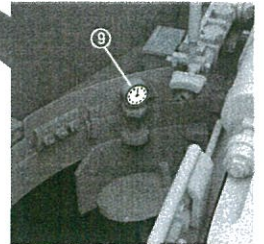

A.MIG 017
Cremeweiss

A.MIG 046
Matt Black

A.MIG 017
Cremeweiss

A.MIG 010
Dunkelgelb

A.MIG 909
Grey Light Base

A.MIG 014
Rotbraun

Porsche Turret

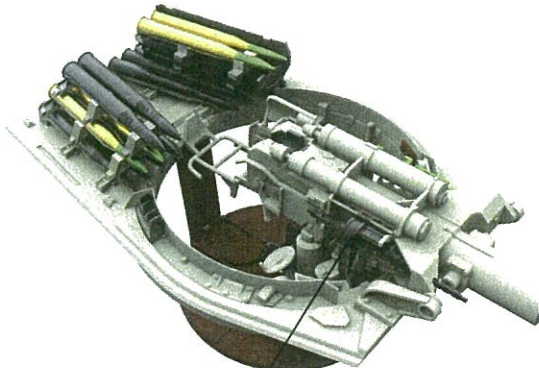

A.MIG 045
Gun Metal

Porsche Turret

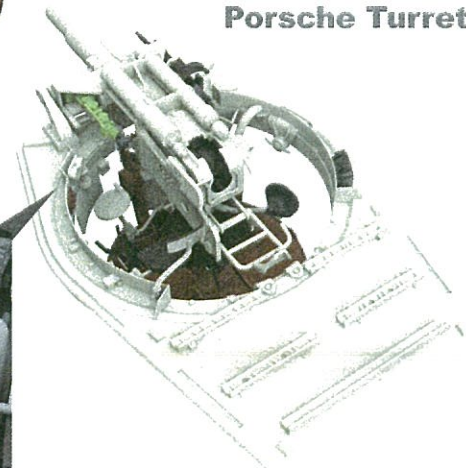

A.MIG 191
Steel

A.MIG 194
Matt Aluminum

A.MIG 032
Satin Black

A.MIG 046
Matt Black

A.MIG 194
Matt Aluminum

A.MIG 014
Rotbraun

A.MIG 032
Satin Black

03.03.2045

2016/2073S

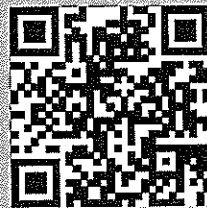
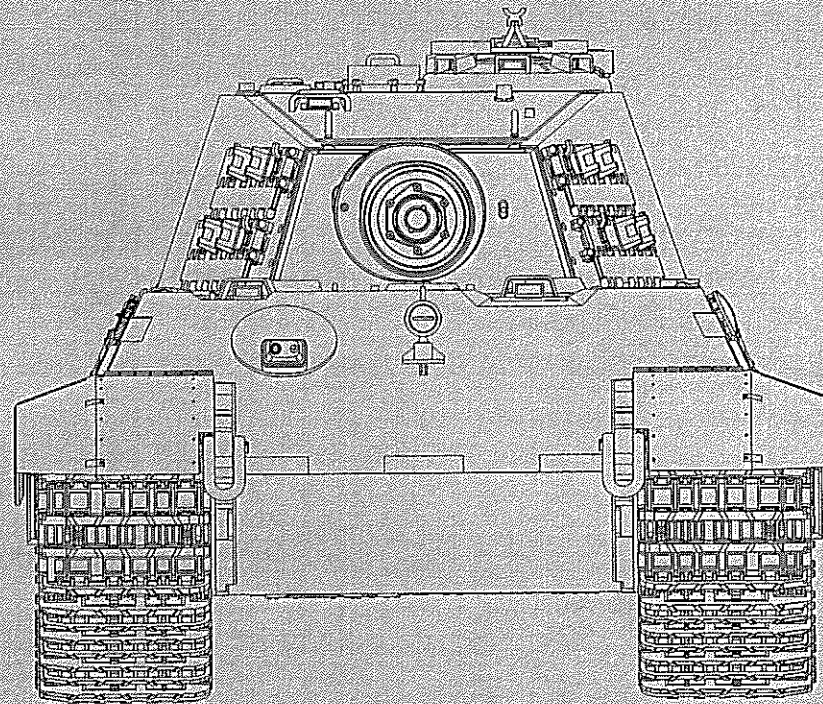

You can find TAKOM on Facebook.com