

SCALE **1:72** UNASSEMBLED PLASTIC MODEL KIT
 МАСШТАБ **1:72** СБОРНАЯ ПЛАСТИКОВАЯ МОДЕЛЬ

CAUTION

When you use glue or paint, do not use near open flame, and use in well ventilated room.
 When you take parts off from the runner frame, use a modeling scissors and trim excess plastic with a cutter or a file.
 See the bottom of this column for the meaning of symbols.

ВНИМАНИЕ

При использовании клея и красок, все работы проводить в проветриваемом помещении вдали от источников огня.
 Детали отделять от литников ножом или другим режущим инструментом.
 Зачистить облой и места среза при помощи надфиля и наждачной бумаги.
 Сборку моделей производить согласно схемы сборки. Для удобства сборки каждая деталь обозначена номером.

A	Parts set Набор деталей	?	Optional Произвольный выбор
15	Part number Номер детали		Repeat at the other side Повторить на другом борту
1	Assembly step Шаг сборки		Open hole Просверлить
B15	Part num. 15 шт set B Деталь 15 в наборе B		Putty hole Шпатлевать
1	x4 Repeat step 4 times Повторить шаг 4 раза		Do not cement Не использовать клей
1	Assembly result at step 1 Результат шага 1		Scratchbuild Сделать самому

F

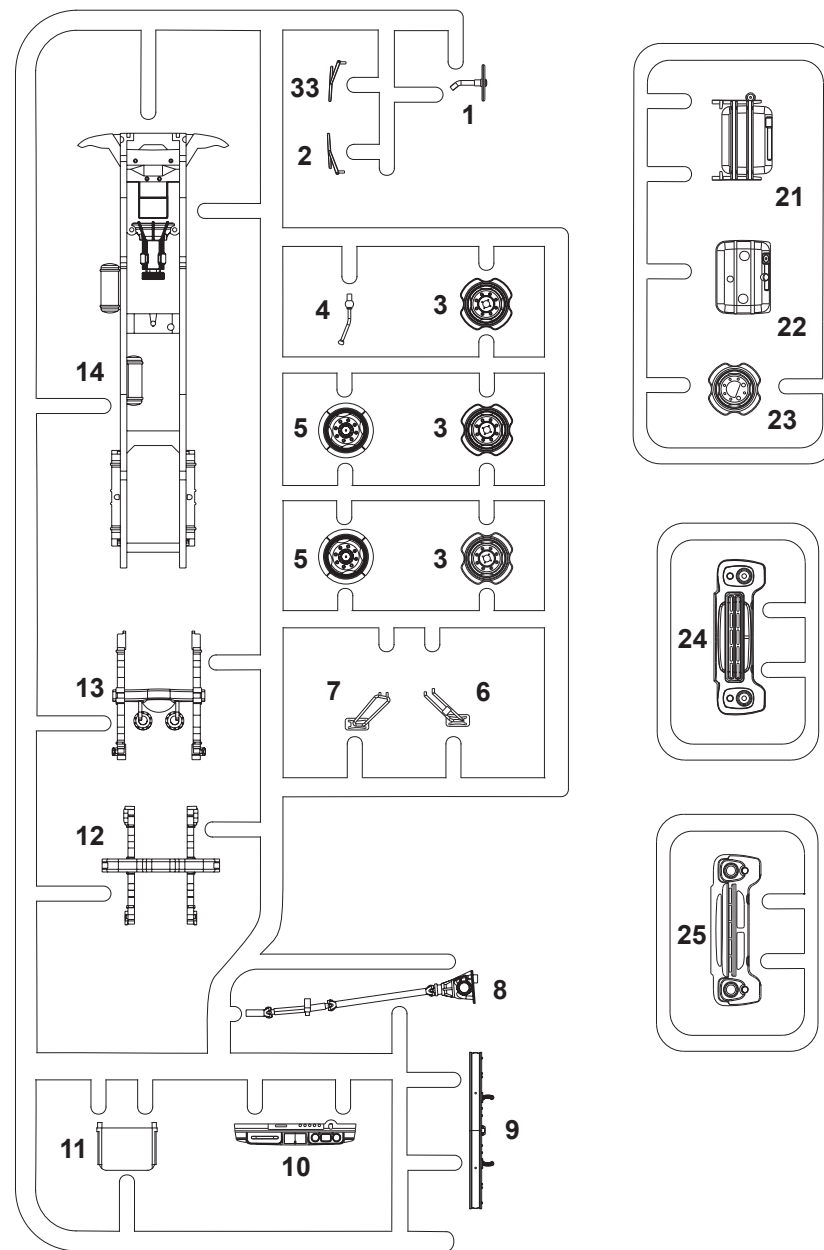

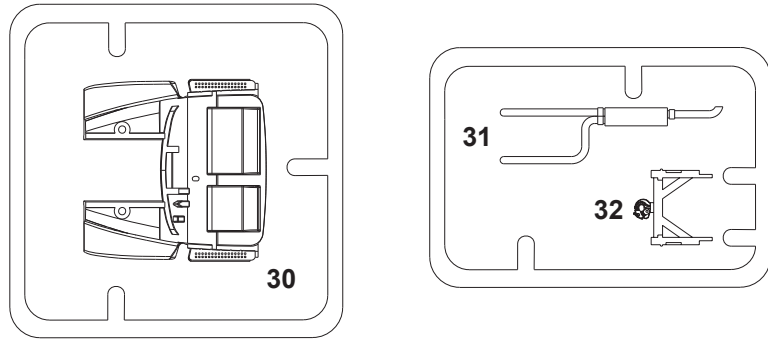
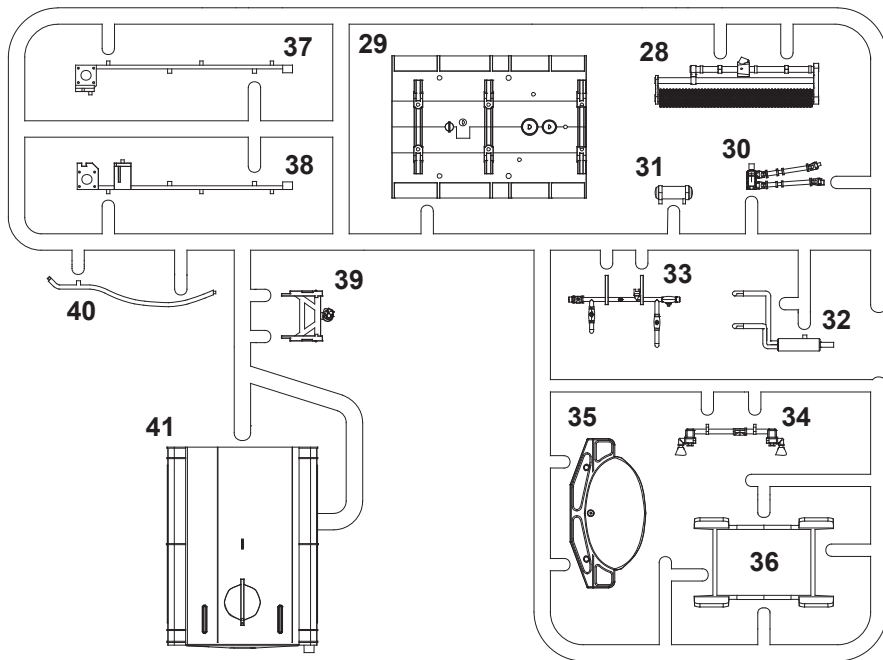
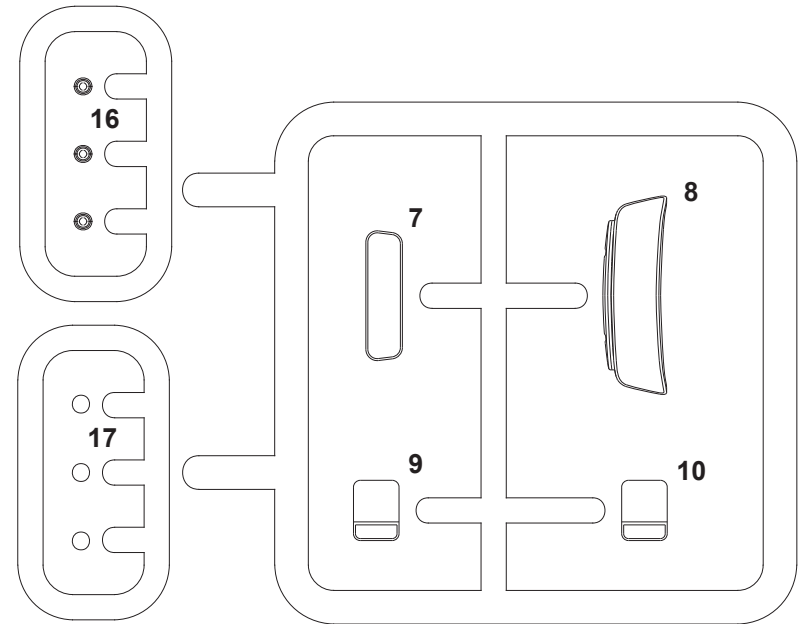
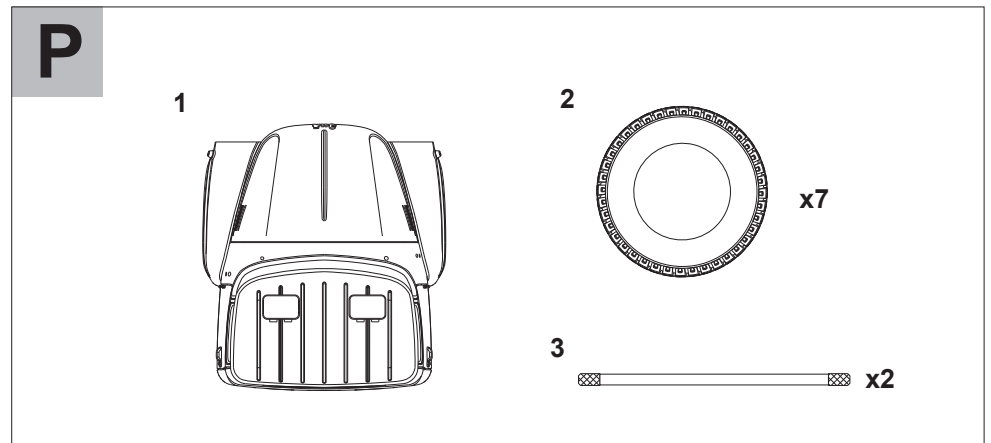
F**AVD**
MODELS**I****E****AVD**
MODELS**P**

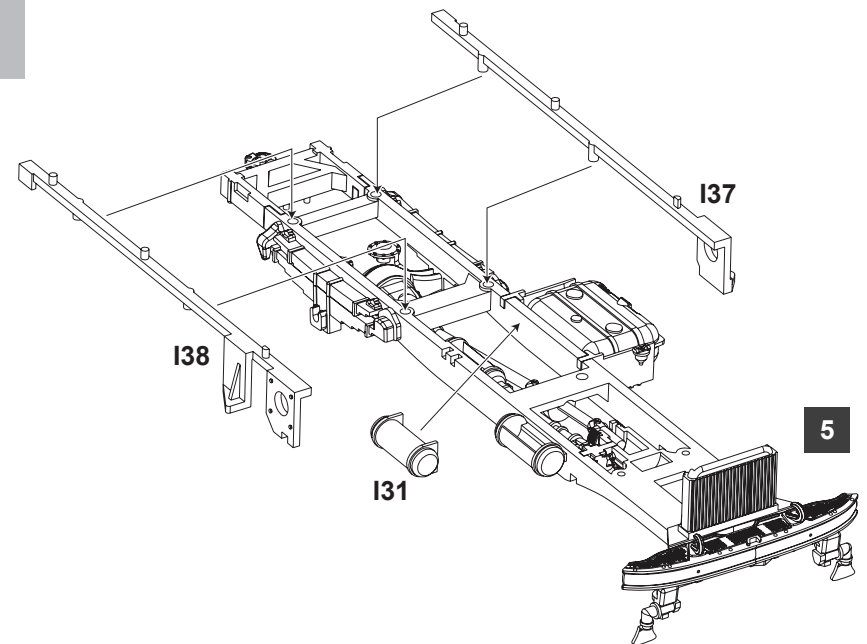
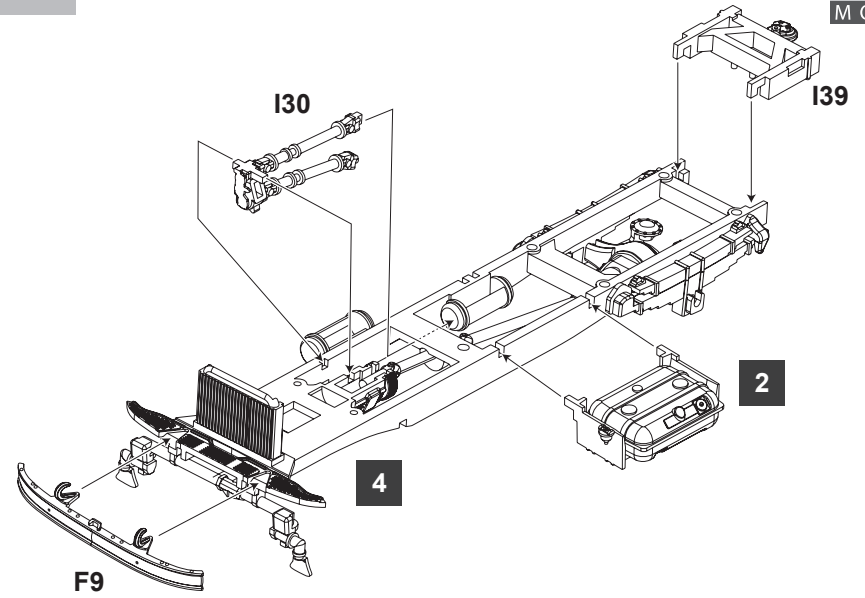
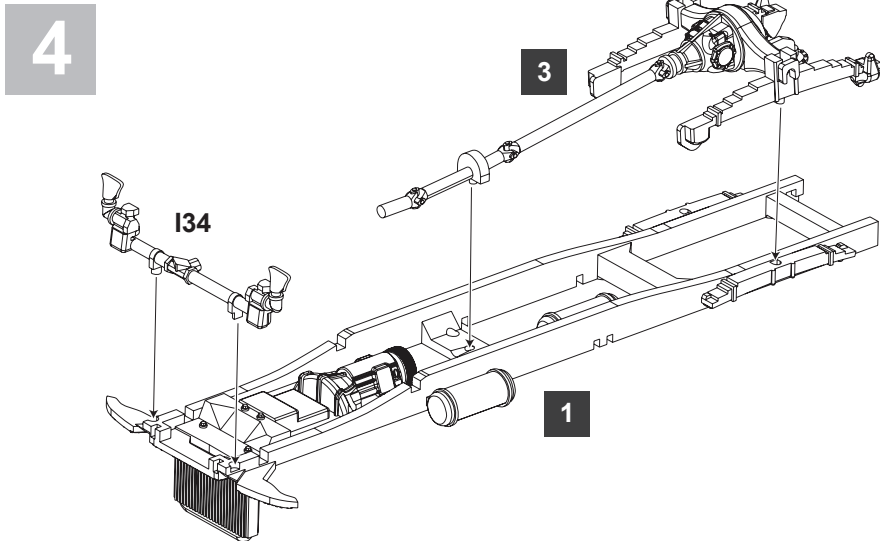
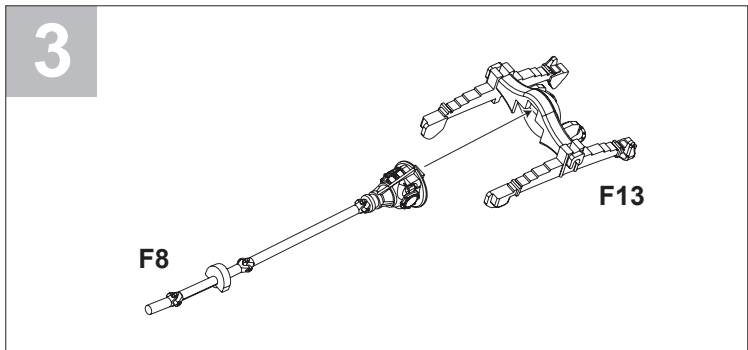
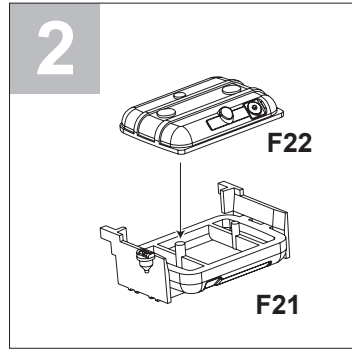
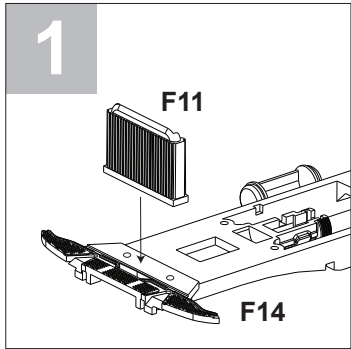

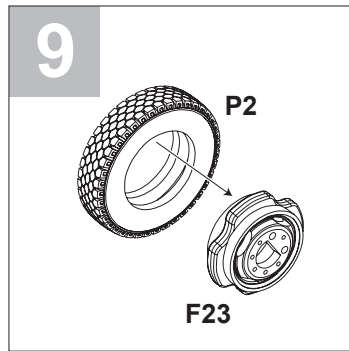
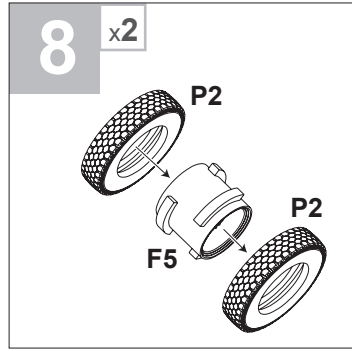
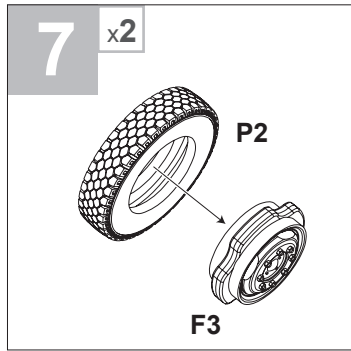

10

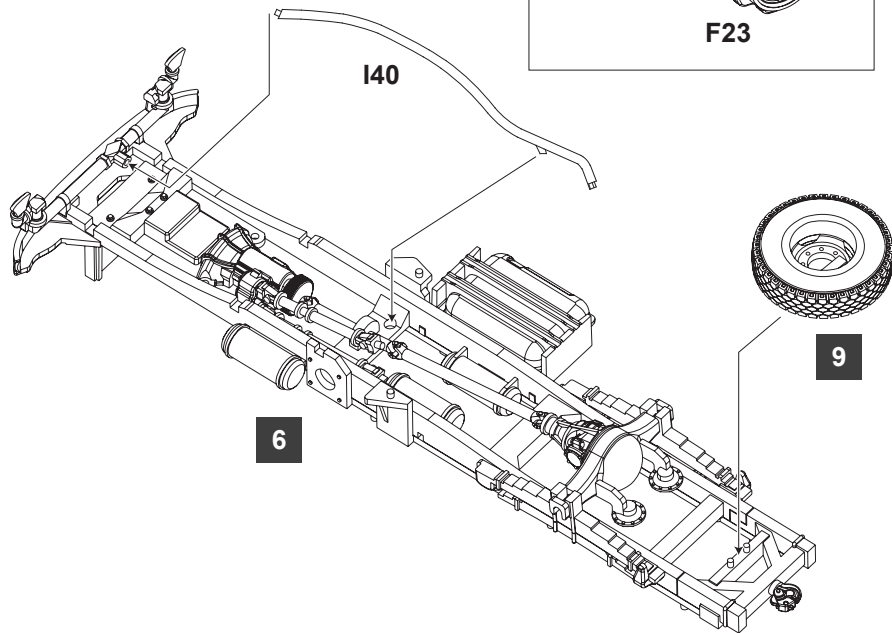

11

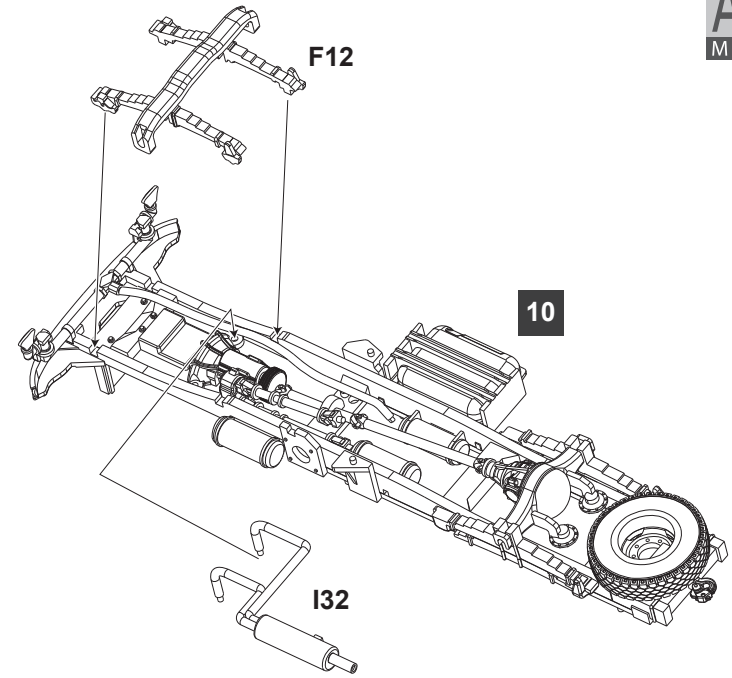

12

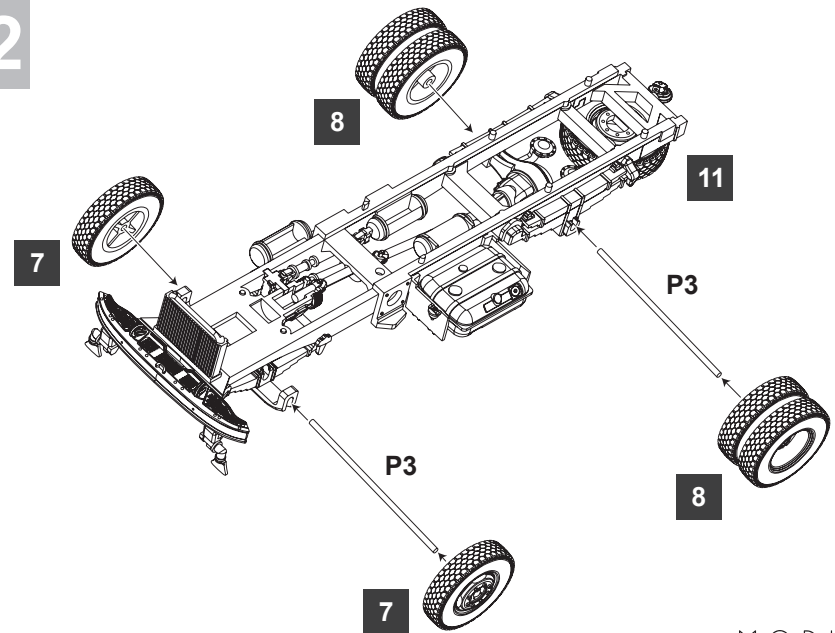

13

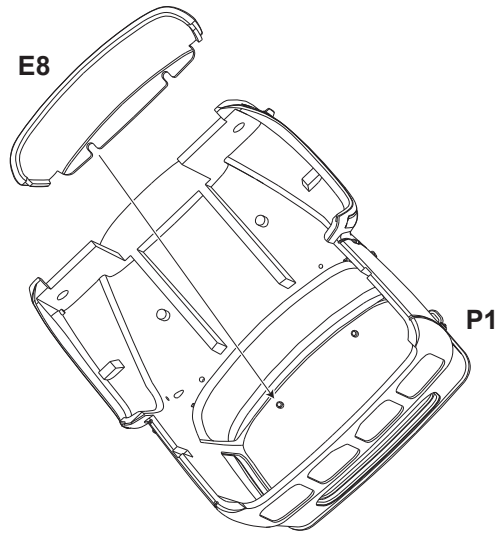

15

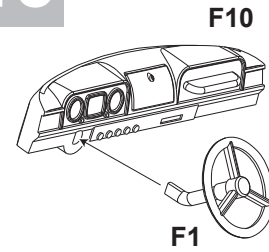

16

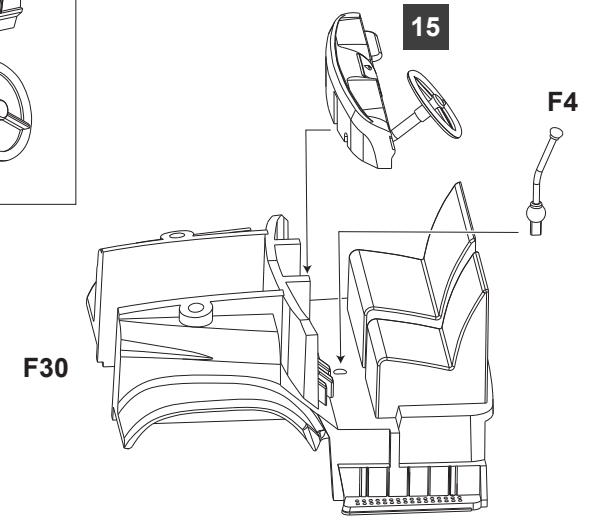

14

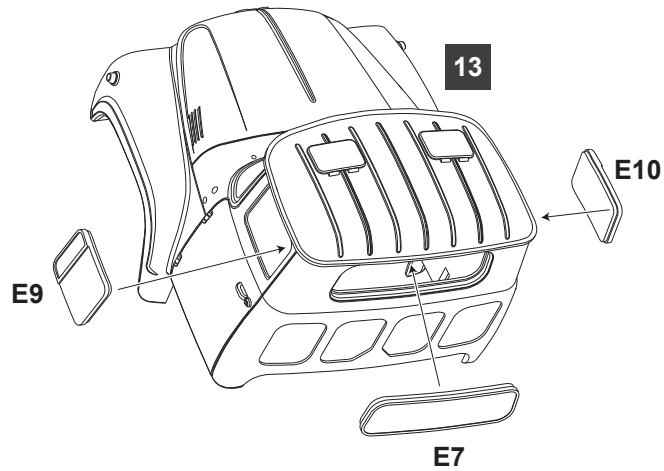

17

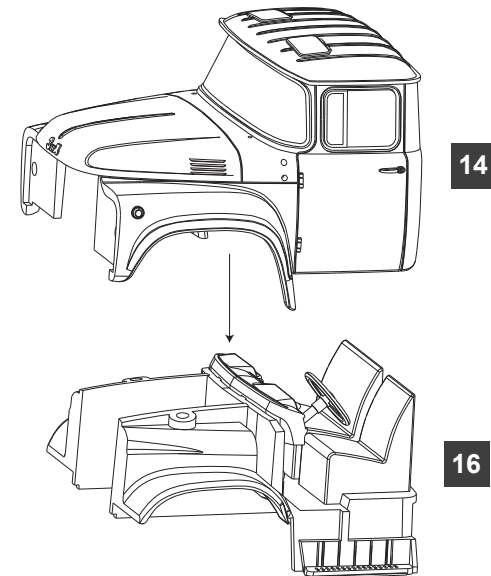

18

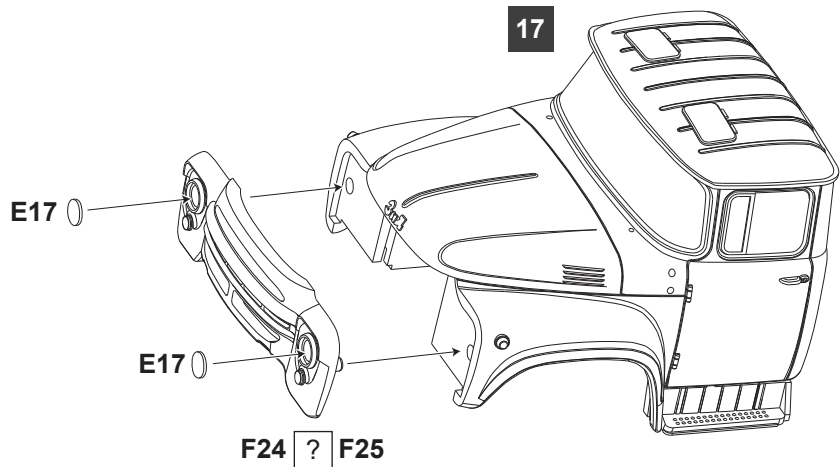

20

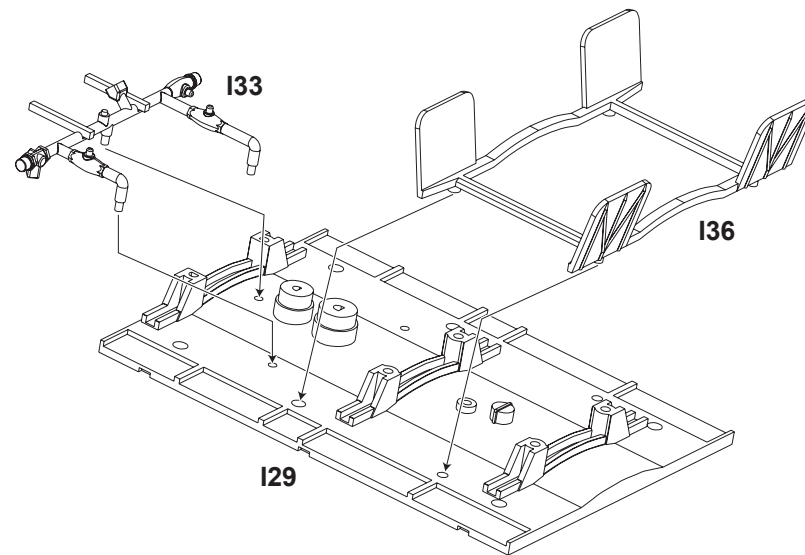

19

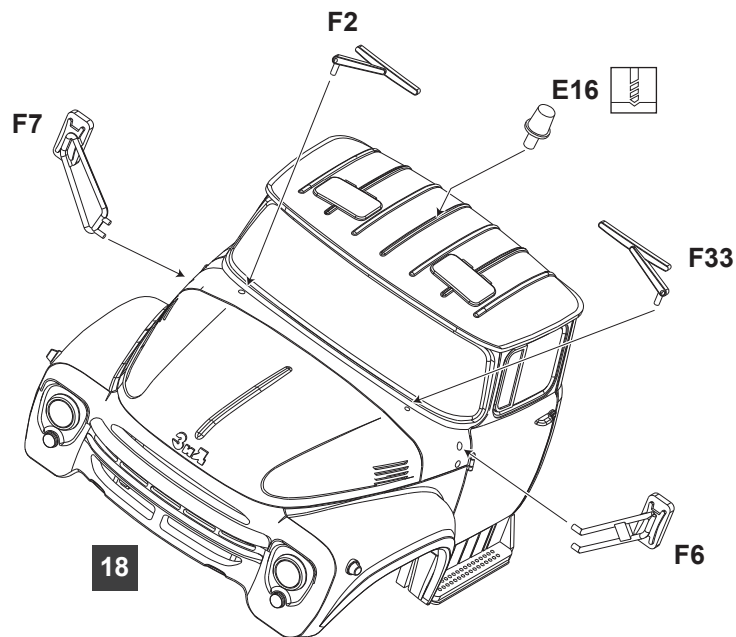

21

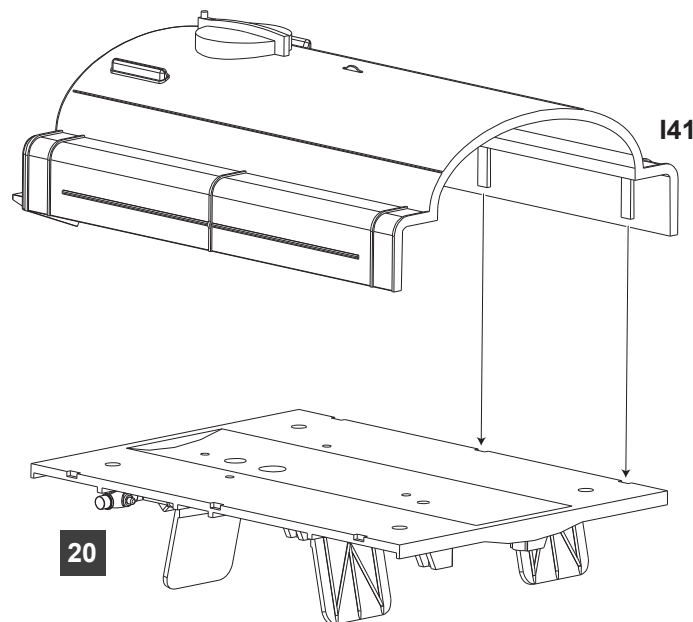

22

AVD
MODELS

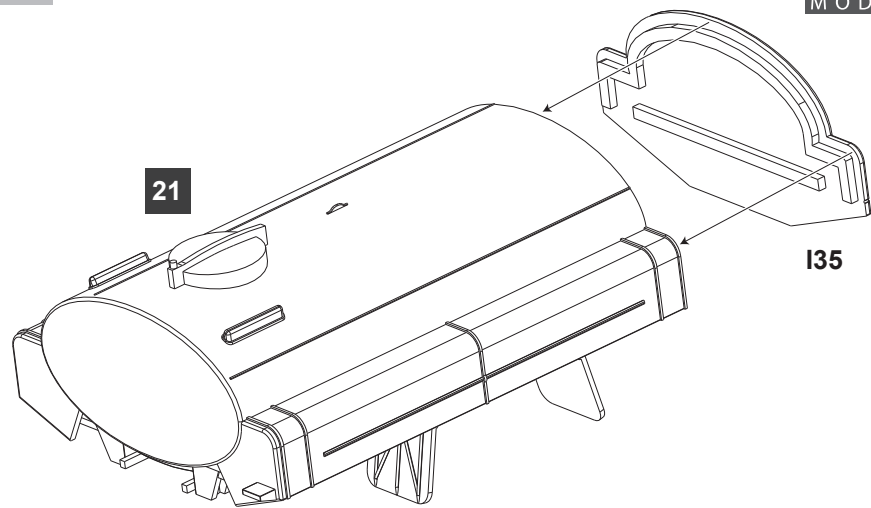

24

AVD
MODELS

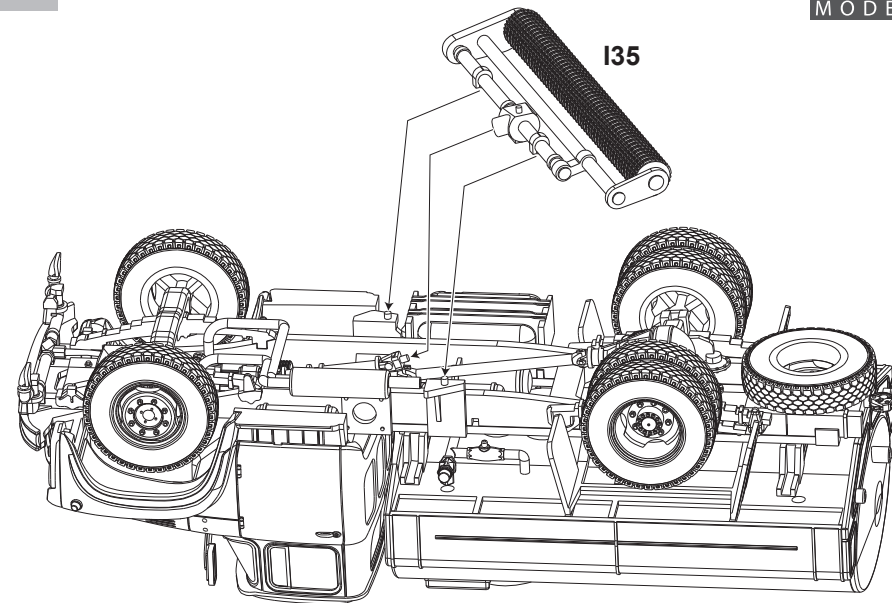

23

