

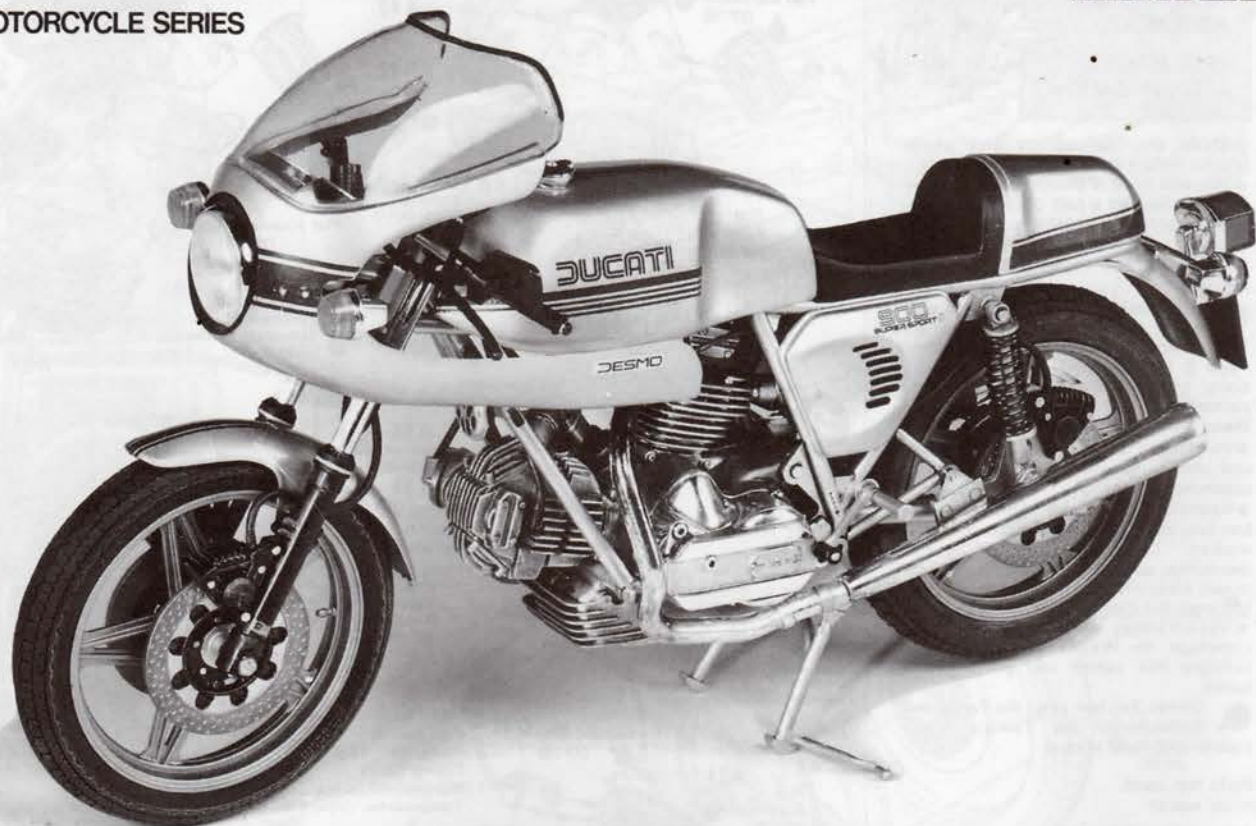

DUCATI 900SS

1/12 MOTORCYCLE SERIES



Only a very few of the many motorcycle manufacturers have enthusiastic supporters from around the world. The Ducati firm is one of them. Each motorcycle made by this famous firm has character and originality. Ducati started making motorcycles in 1946, just after world war 2, and shortly became known for their expertise in the field of racing. The Ducati 900SS (Super Sport) made its debut in 1975 and was the fastest model built by them which had the outlines of a racing machine. Using the 90 degree "L" twin format, made famous by Ducati, and the Desmodromic valve system, this slim machine quickly gathered fans from around the world. The "L" format engine, said to be symbolic of Ducati, is derived from the 1260cc V4 cylinder engine that was released in 1963 and known as the Apollo. In 1954 a Ducati engineer named F. Taglioni, developed a new valve system that used cams for both opening and closing the valves. This eliminated the "valve float" that occurs at high RPM's in four stroke 125cc engines and allowed up to 15,000 RPM rather than the usual 12,000. First used on a motorcycle in 1955, and the first use of this system in the "L" format was with the Ducati 750SS Imola Replica released in 1973. It finished number 1 and 2 at the Imola 200 mile race and was accepted as a real threat to the larger bore bikes. The 900SS uses a bored out Imola engine of 863.9cc in two cylinders configured in a 90 degree "V" with the front cylinder parallel to the road surface and the rear cylinder vertical, hence the "L" format, and it used separate twin carburetors. This combination produces 75hp and the SS is capable of a top speed in excess of 215km/h. As weight is of paramount impor-

tance in racing motorcycles, engine starting is via kick starter only, to eliminate the excess weight of a starter. The slim and simple styling was taken from the Ducati 750 and the racing mood enhanced by use of a clip on handle bar, long slim fuel tank and the use of a half cowling for streamlining. The production machines are produced with the longer double saddle; however, many of these have been altered to the single "Imola" seat. The 900SS has been very active in competitive racing, and has competed against the large bore Japanese bikes in world endurance racing and it won the 1978 Isle of Man Tourist Trophy classic. After this victory Ducati released the Mike Hailwood Replica and it became extremely popular amongst bike enthusiasts. In 1983 the 900S2 made its debut and the 900SS was retired from the position of Ducati's fastest motorcycle.

* * *
Nur wenige der vielen Motorradhersteller haben begeisterte Unterstützung aus der ganzen Welt gefunden. Eine Firma davon ist Ducati. Jedes Motorrad dieser bekannten Firma hat seine Originalität und auch seine Eigenschaften. Ducati begann 1946 und wurde bald bekannt für seine Erfahrungen und Erkenntnisse aus dem Motorsport und der Motorradrennen. Die Ducati 900SS (Super Sport) kam 1975, es war die schnellste Strassenmaschine mit dem Aussehen einer Rennmaschine. Diese schlanke Motorrad hatte das Desmodromic Ventil-System und den 90 Grad "L" Motor, symbolisch für Ducati, und wurde schnell unter den Motorradfans auf der ganzen Welt bekannt. Der "L" Motor wurde vom 126cc V 4-Zylinder Motor abgeleitet, der 1963 als "Apollo" herauskam. 1954 entwickelte der Ducati-Ingenieur F. Taglioni ein neues System, welches

zum Öffnen und Schliessen der Ventile nur noch Wellen hatte. Dadurch konnten die üblichen 12.000 RPM der Vierzylindermaschinen auf 15.000 RPM gesteigert werden. Erstmals 1955 in einer 125cc Maschine, wurde dieses System 1973 in der 750SS Imola Replica von Ducati verwendet. Bei dem 200 Meilen-Rennen in Imola wurden mit diesem Motorrad der erste und auch der zweite Platz belegt, es erwies sich dieses System für grosse Maschinen mit grossem Hubraum bestens geeignet. Die 900SS hat einen aufgebohrten Imola-Motor mit 863,9cc, zwei Zylinder in 90 Grad "V", der vordere Zylinder liegt quer zur Strasse, der hintere Zylinder steht jedoch senkrecht — daher "L" Format — und hat zwei getrennte Vergaser. Diese Kombination bringt 75 PS und die SS kommt auf 215/stde. Das Gewicht der Rennmaschine ist äusserst wichtig, daher wird auch mit einem Kickstarter gestartet. Das schlanke und einfache Styling kommt von der Ducati 750, langgezogener schlanger Tank und eine halbe Verkleidung bringen die Stromlinienform. Die Produktionsmaschinen haben einen langen Doppelsattel, jedoch viele bevorzugen den "Imola-Einzelsitz". Die 900SS war sehr aktiv im Rennsport und konnte gegen die grossbohrigen Japaner im Langstreckenläufen bestens konkurrieren. Ducati gewann mit der 900SS die Tourist Trophy 1978 der Isle of Man. Nach diesem Sieg brachte Ducati die Mike Hailwood Replica heraus und wurde dadurch aussergewöhnlich unter den Motorradfans bekannt. 1983 verdrängte dann die 900S2 die 900SS vom Platz der schnellsten Maschine aus dem Ducati-Rennstall.

3 <Battery> <Batterie>

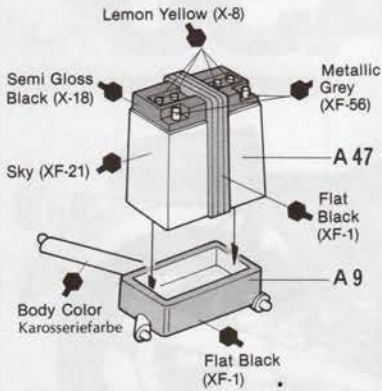

4 <Attached Engine> <Eingebauter Motor>

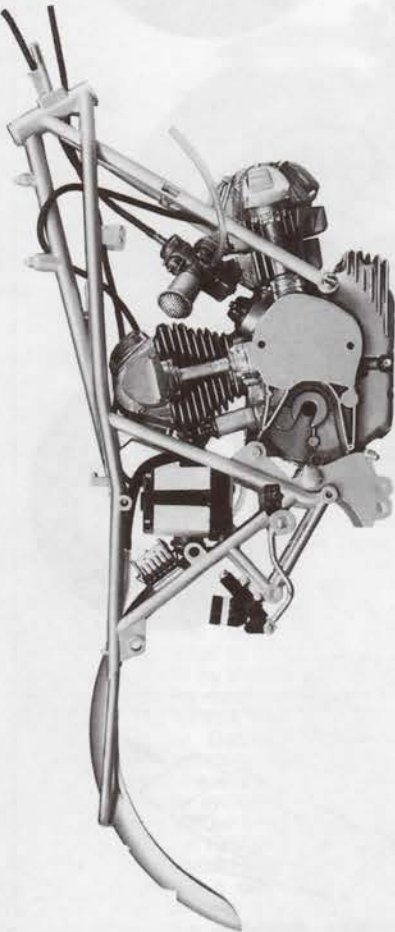

★ Before cementing plated parts, remove plating with a knife etc. from the surface to which cement is applied.
★ Chrometeile: Vor dem Kleben muss an den Klebestellen die Chromschicht abgeschabt werden, da sonst Klebstoff nicht bindet.

3 Assembly of Frame Montage des Rahmens

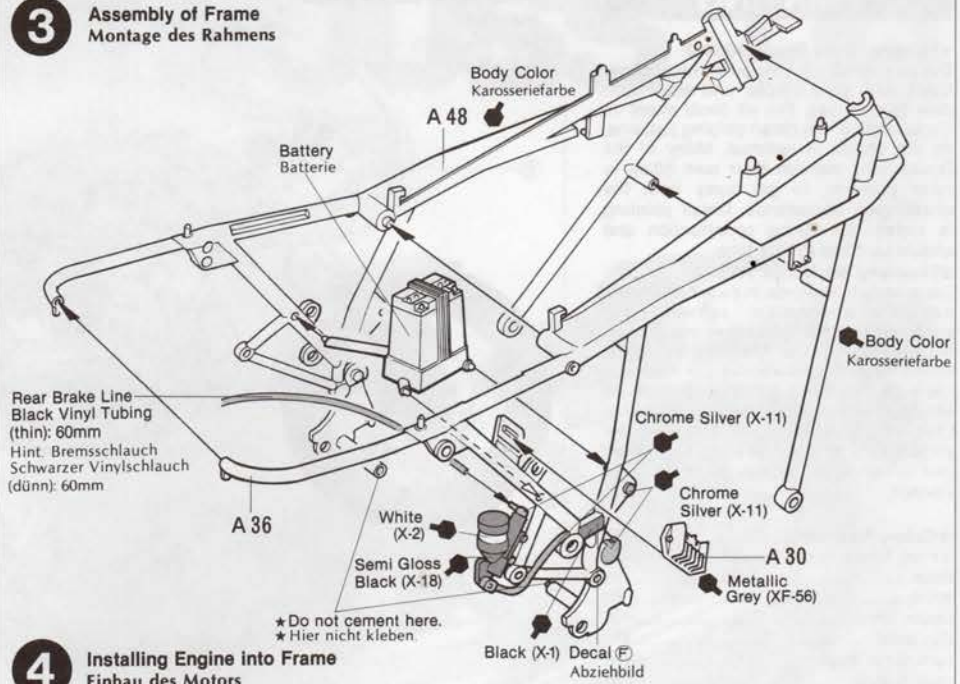

4 Installing Engine into Frame Einbau des Motors

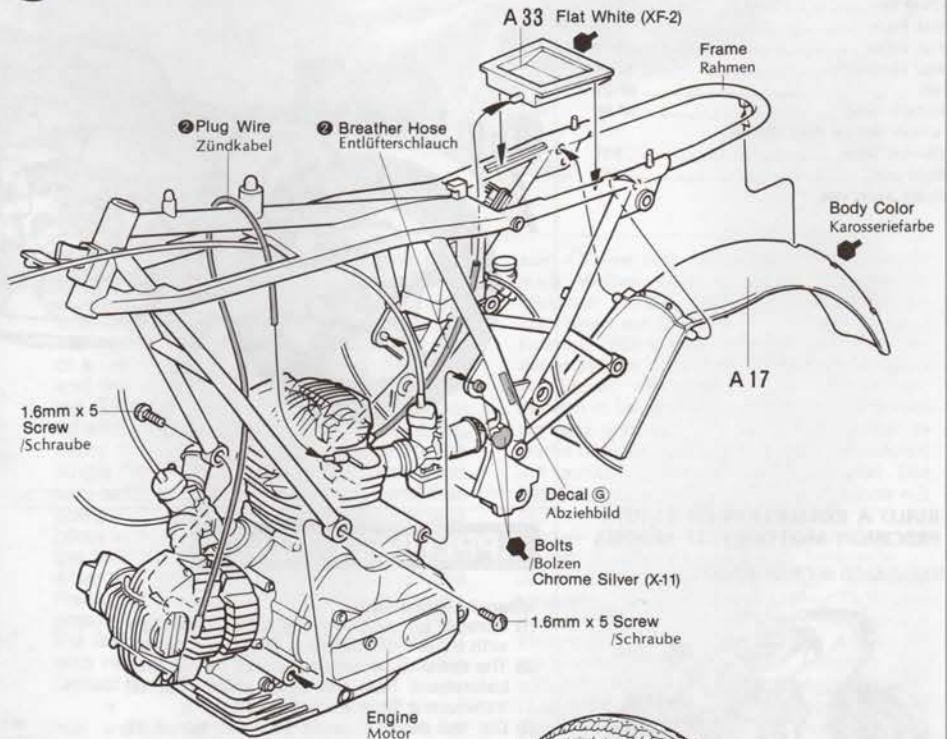

5 Assembly of Rear Wheel Hinterrad

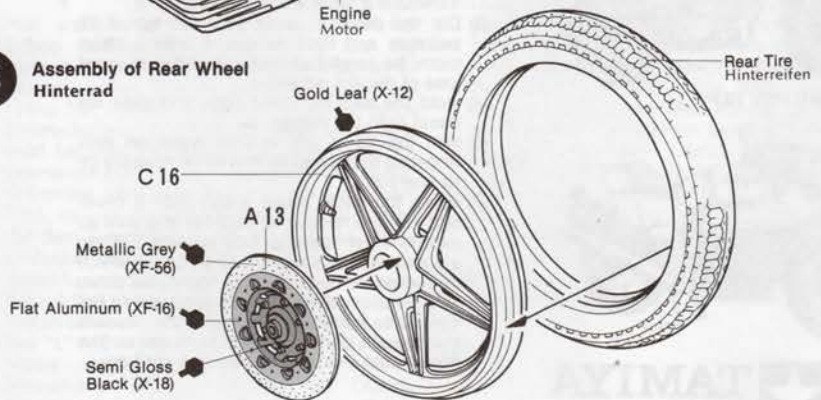

6 «Swing Arm»
«Radgabel»



6 Assembly of Swing Arm
Montage der Radgabel

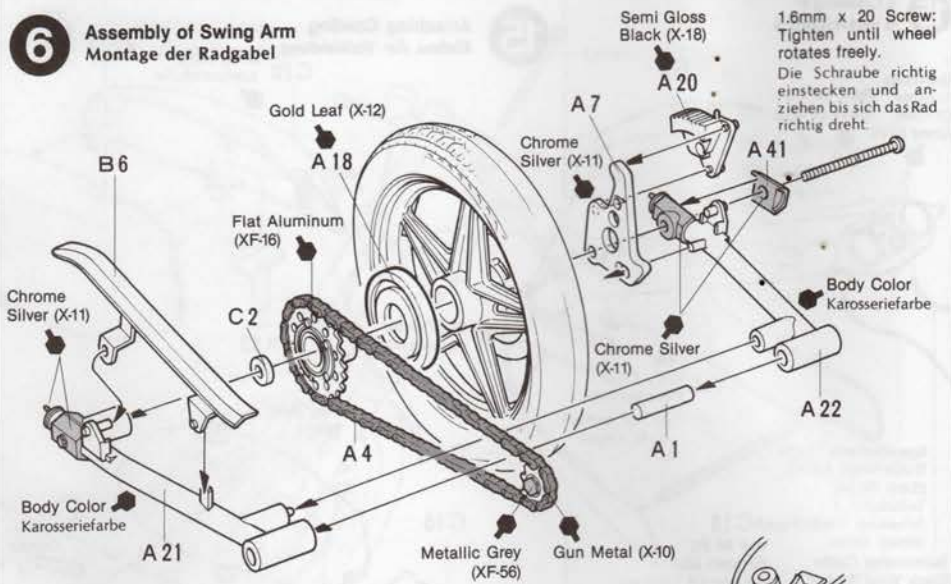

7 «Rear Shock Absorber»
«Hinterstossdämpfer»

* Make 2 sets.
* 2 Satz machen.

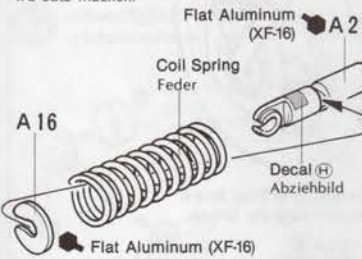

«Rear Brake Line»
«Hinterer Bremschlauch»

③ Rear Brake Line
Hinterer Bremschlauch

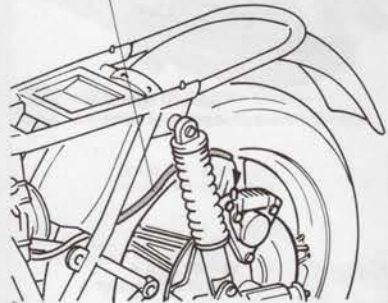

7 Attaching Swing Arm
Radgabel Einbau

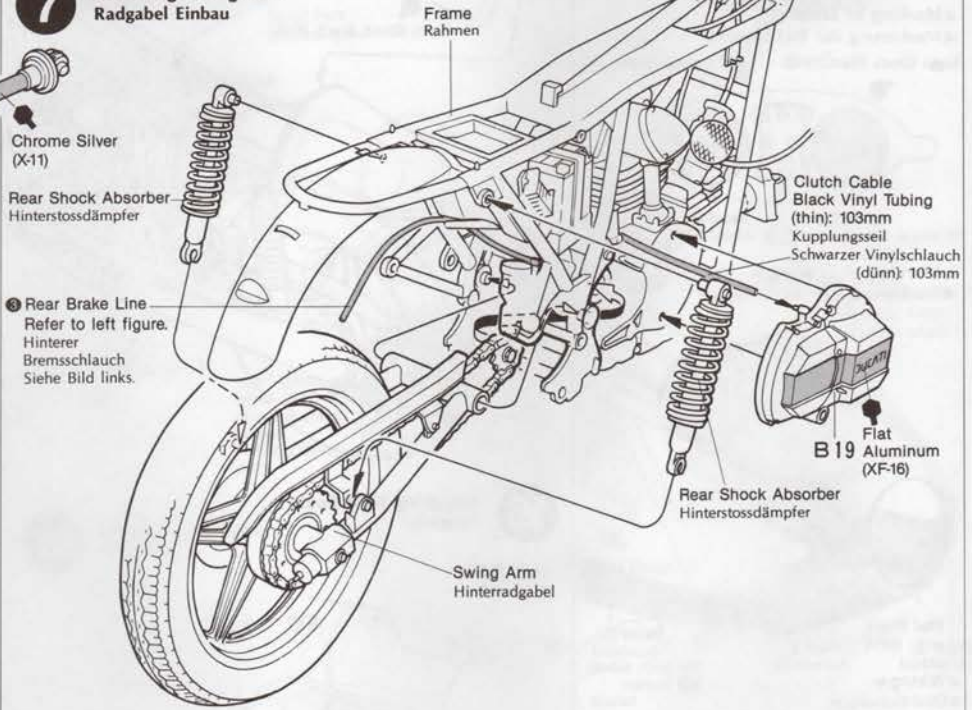

8 Assembly of Mufflers
Auspuff

«Right»
«Rechts»

«Left»
«Links»

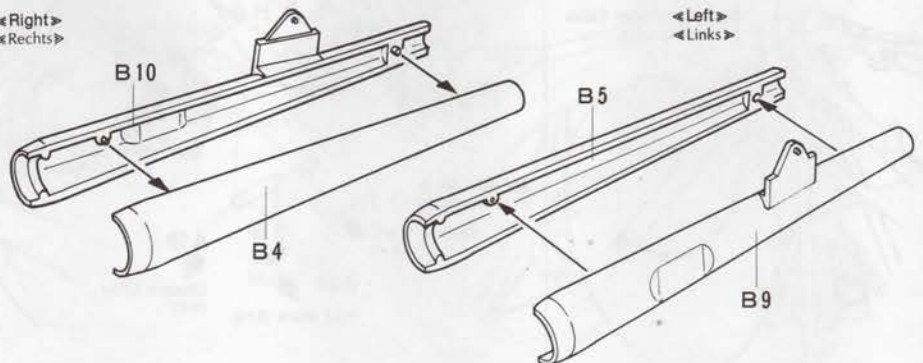

9 «Attached Mufflers»
«Eingebaute Auspuff»

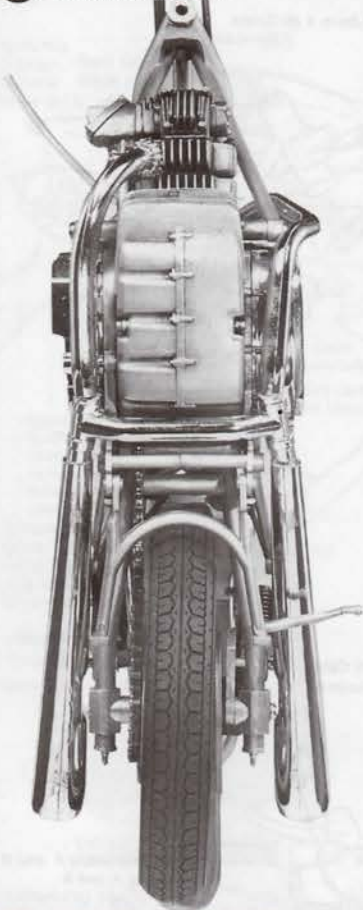

9 Attaching Mufflers
Einbau des Auspuffs

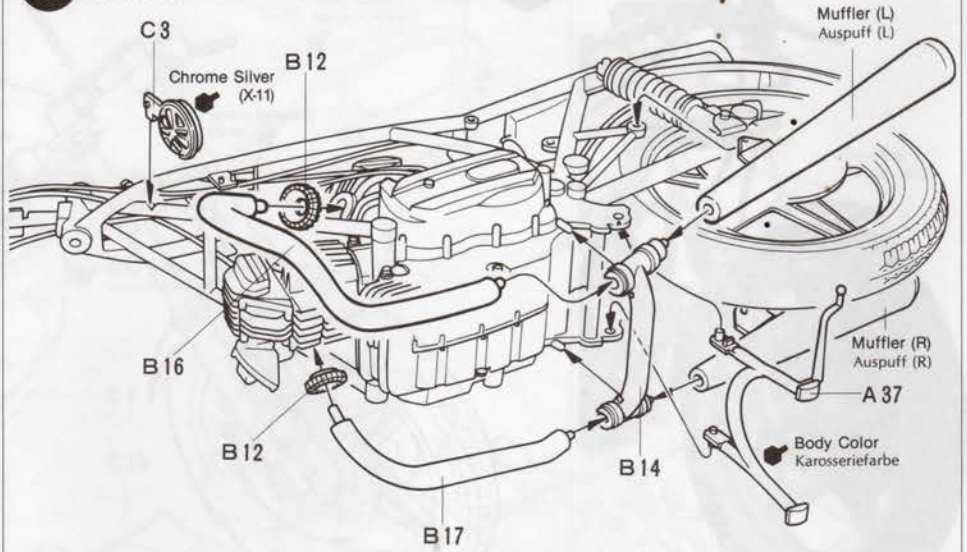

11 «Assembly of Handle-Bar»
«Lenkstange»

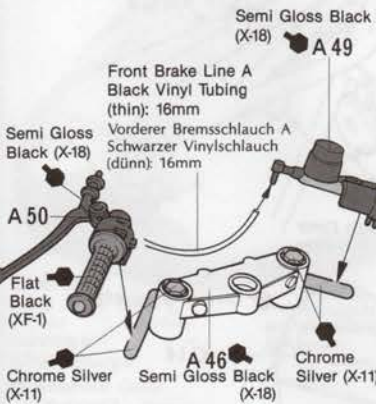

«Attaching A49 and A50»
«Einbau A49 und A50»
Attach A49 and A50 to A46 as shown below.
A49 und A50 auf A46 einbauen, wie gezeigt unten.

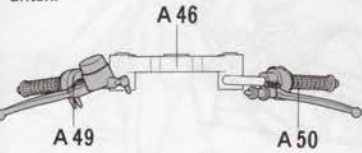

10 Assembly of Front Wheel
Vorderrad

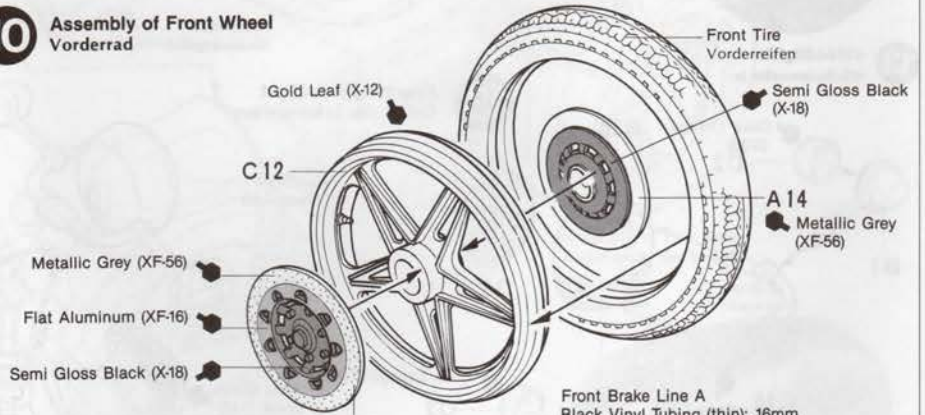

11 Assembly of Front Fork
Zusammenbau der Vorderradgabel

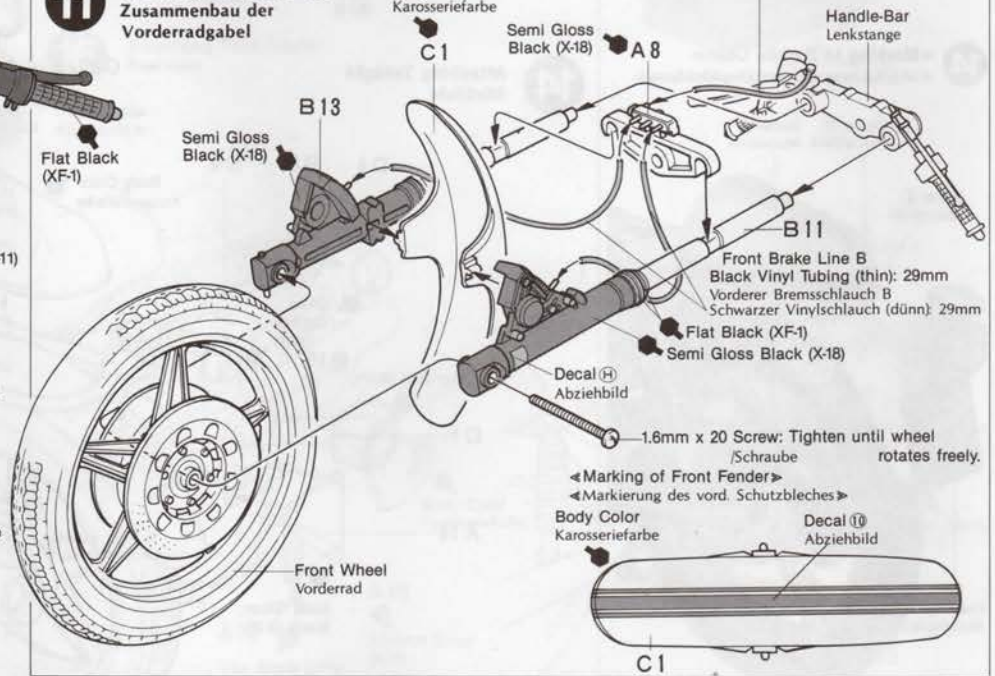

12 <<Attached Front Fork>>
<<Vorderradgabel>>



12 Attaching Front Fork
Einbau der Vorderradgabel

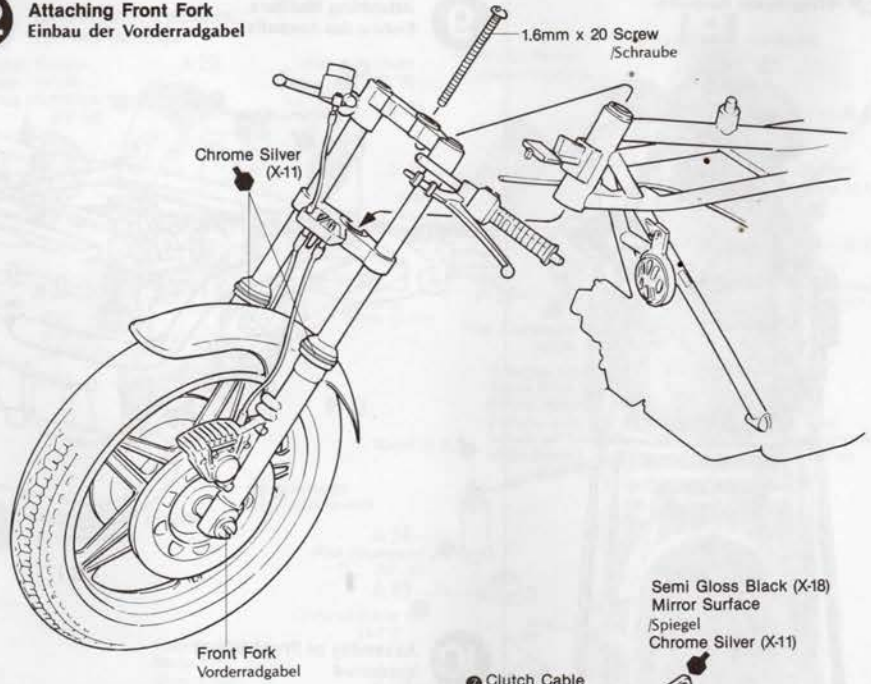

13 <<Headlight>>
<<Scheinwerfer>>

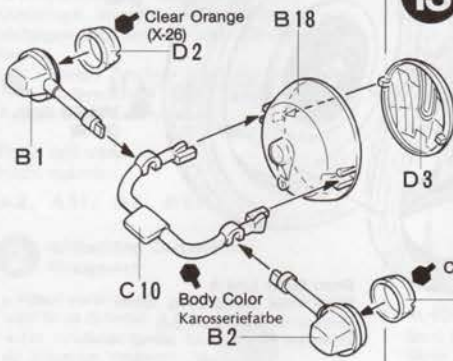

13 Attaching Headlight
Einbau des Scheinwerfers

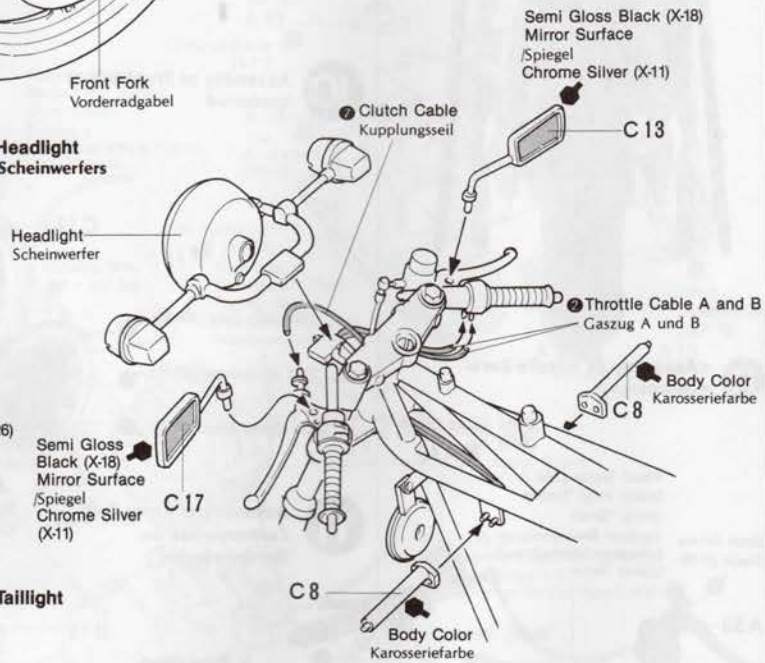

14 <<Marking of Saddle Cowl>>
<<Markierung der Sattelverkleidung>>



14 Attaching Taillight
Rücklicht

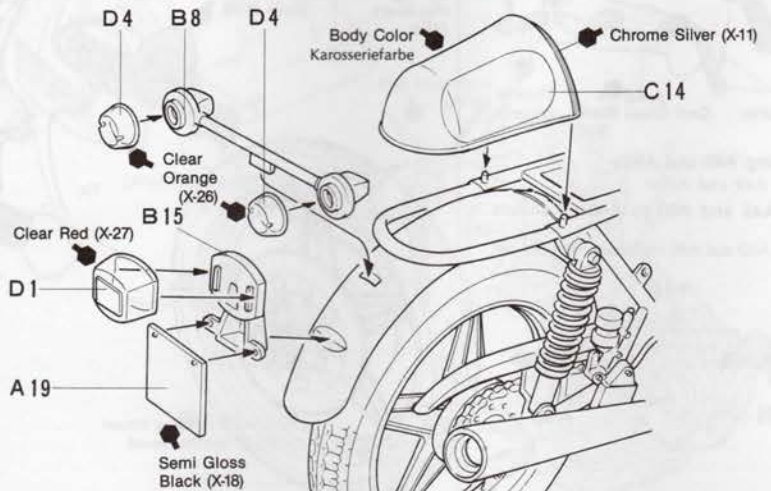

15 <<Cowling>>
<<Verkleidung>>

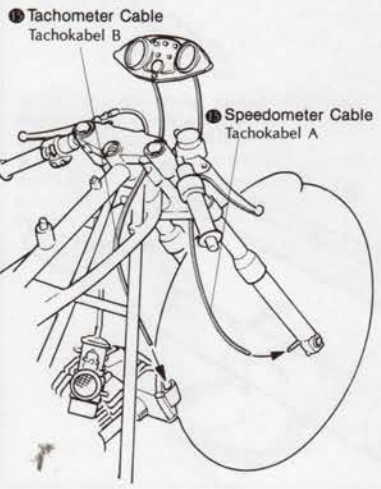
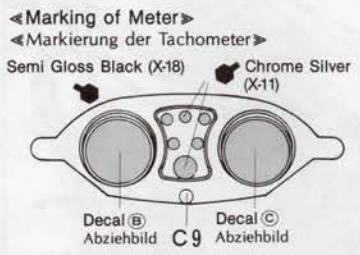
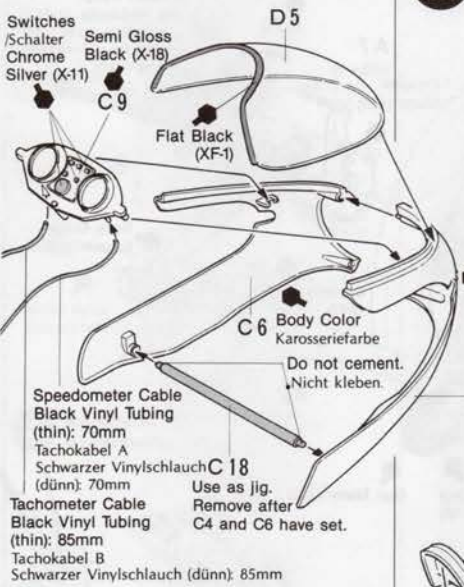

15 Attaching Cowling
Einbau der Verkleidung

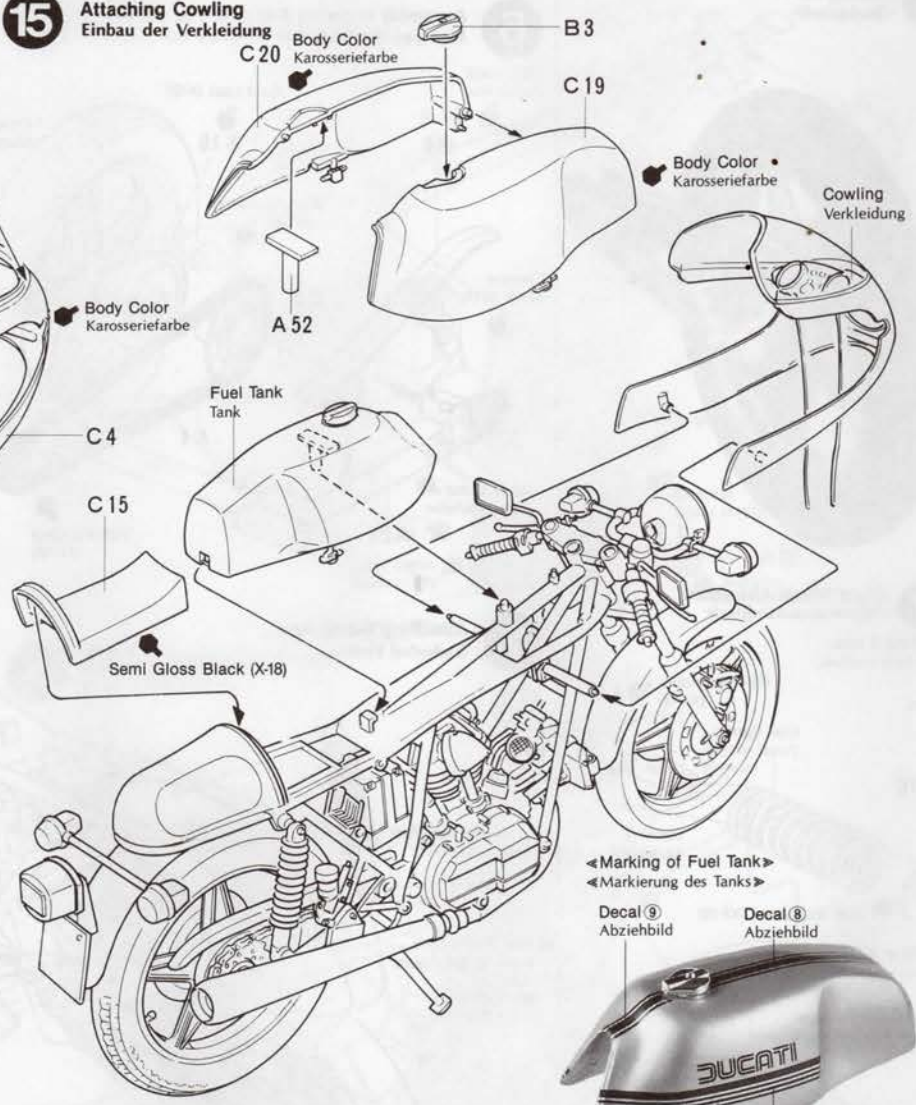

16 Attaching Foot Rests
Fussraster

<<Left Side>>
<<Linksseite>>

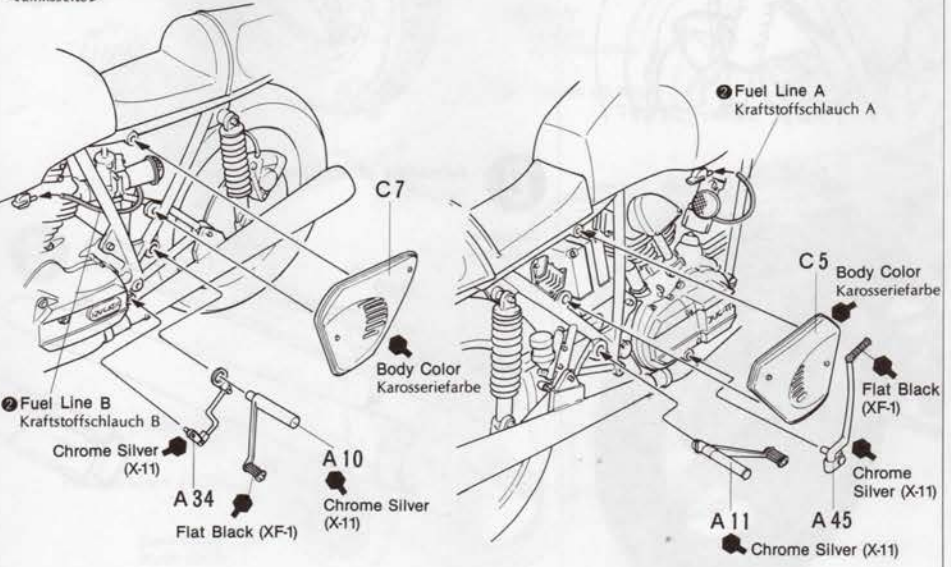

PAINTING

«Painting of the Ducati 900SS»

Ducati's 900SS is offered in two colors. Black with gold stripes and silver with dark blue stripes. The kit decal sheet includes both of the detail striping patterns, so the choice is optional. Many of the Ducati fans painted their own bikes in other patterns, to get away from the stereotyped appearance. Detail painting is called out during construction and should be done at that time.

«Bemalung der Ducati 900SS»

Diese Maschine wurde in zwei Farbkombinationen angeboten: schwarz mit goldenen Streifen oder silber mit dunkelblauen Streifen. Die Abziehbilder im Kit haben beide Streifenmuster zur Auswahl. Viele Ducati Fan's bemalen jedoch ihr Motorrad in anderen Farben, um sich vom Üblichen zu unterscheiden. Bemalung der Details sind in der Anleitung angegeben und sollten je nach Step sofort gemacht werden.

«Colors Required»

★ From Tamiya Acrylic Paints



Black	X-1
White	X-2
Lemon Yellow	X-8
Gun Metal	X-10
Semi Gloss Black	X-18
Clear Orange	X-26
Clear Red	X-27
Flat Black	XF-1
Flat White	XF-2
Flat Aluminum	XF-16
Sky	XF-21
Metallic Grey	XF-56

★ From Tamiya Paint Marker

Chrome Silver	X-11
Gold Leaf	X-12
Gloss Aluminum	

«Marking of Ducati 900SS»

Body Color

-  Black (X-1)
-  Gloss Aluminum

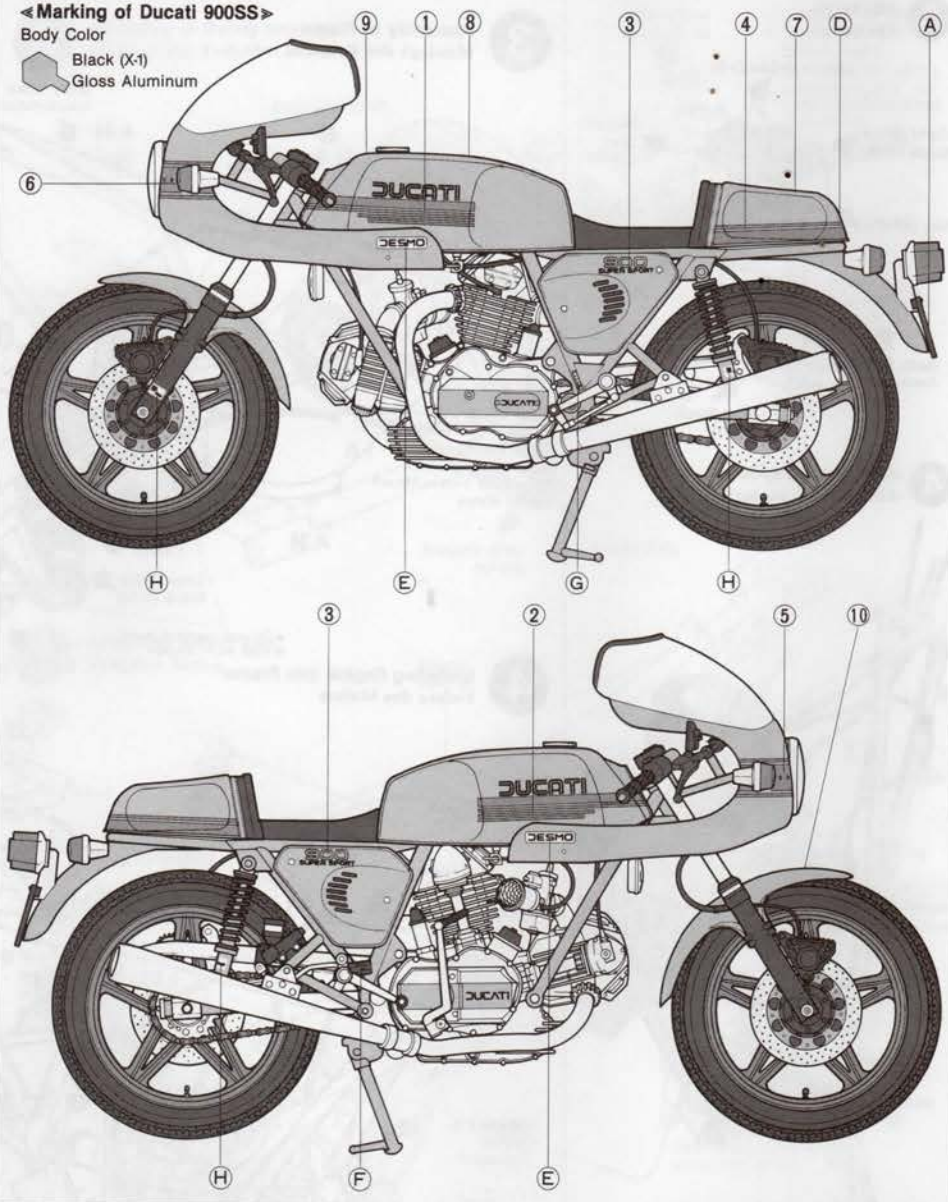

BUILD A COLLECTION OF TAMIYA PRECISION MOTORCYCLE MODELS

1/12 DUCATI 900NCR RACER



1/12 DUCATI H.W. REPLICA

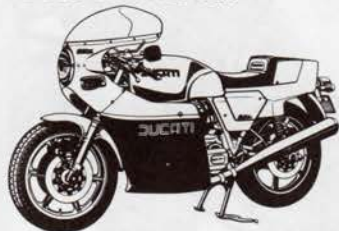

APPLYING DECALS

«Decal Application»

- (1) Remove all dust, dirt and adhesive smears with a wet cloth before applying any decals.
- (2) The decal to be applied should be removed beforehand from the decal sheet. Cut off translucent films along colored parts.
- (3) Dip the decal in tepid water for about 10 seconds and then remove it onto a clean cloth. Be careful of over immersion to avoid loss of decal's adhesive.
- (4) Hold the backing sheet edge and slide the decal onto the model.
- (5) Wet the decal with a little water on your finger so that it can be moved more easily into position.
- (6) Press the decal down gently with a clean soft cloth to remove air bubbles and until all excess water has been fully absorbed. When a decal has to be applied to a surface which is uneven or curved, press the decal down with a hot towel so that the decal will fit the contours perfectly. Cut off the excess transparent portion around each decal. The decal must then not be touched until dry.

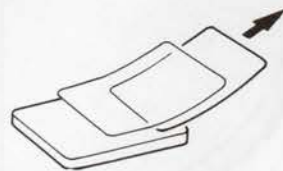

«Abziehbilder - Decals»

- (1) Staub, Schmutz und Klebstoffreste mit nassem Tuch entfernen.
- (2) Decals erst ausschneiden entlang den Linien.
- (3) Decals in Wasser legen, dann nach 10 Sekunden auf z.B. Handtuch legen und etwas abtrocknen lassen.
- (4) Decal an der Unterlage halten und Bild auf das Modell schieben.
- (5) Mit etwas Wasser auf dem Finger lässt sich das Decal noch etwas verschieben.
- (6) Decal mit etwas Stoff gut andrücken um die Luftblasen zu entfernen und das Wasser abzutrocknen. An unebenen Stellen kann man mit heissen Tuch das Decal besser andrücken. Transparente Überreste am Decal abschneiden. Decal nicht mehr berühren, bis getrocknet ist.