

KING TIGER

Sd.Kfz.182

PORSCHE TURRET
W/ZIMMERIT

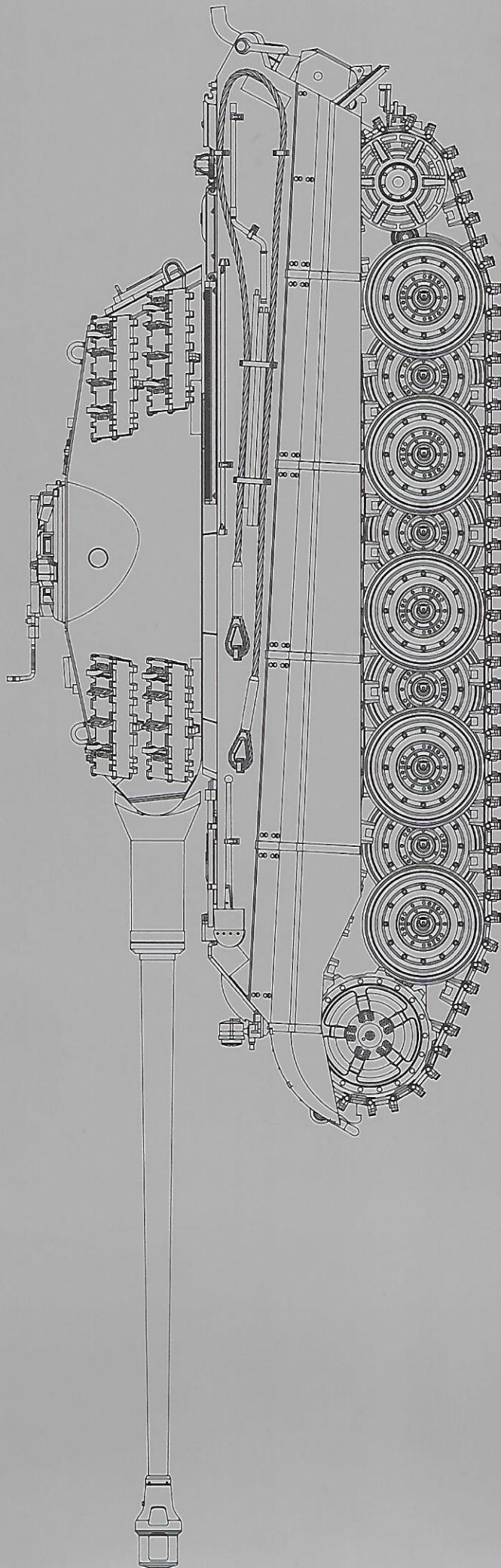

The German Tiger Ausf. B, or King Tiger, was arguably the very best tank that was put onto the battlefield during WWII, as well as the most costly. With each unit requiring some 300,000 skilled man-hours to complete, the King Tiger went into serial production in December 1943 at the Henschel factory in Kassel. At the peak of production it took only 14 days to complete, and by the end of the war 492 examples were ultimately produced of the 1500 units ordered due to the intense Allied bombing campaign.

With frontal armor reaching up to 160mm thick and side armor 80mm thick, this nearly 70 ton tank was built around the famous dual-purpose semi-automatic 88mm cannon firing armor-piercing or high explosive rounds, the KwK 43 (L71) produced by Krupp, with the TZF9b/1 binocular gun sight (later followed by the monocular TZF9d) built into the cradle. This set-up allowed the tank to engage virtually any enemy tank before it could come within firing range. The King Tiger with Porsche turret carried a maximum combat load of 80 rounds of internally stored ammunition. Additional armament came in the form of 3 Rheinmetall Maschinengewehr 34's with 5800 rounds; one mounted in a Kugelblende on the right bow position; one mounted coaxially to the main gun; one mounted externally to the commander's cupola.

This massive tank was mobilized by a OLVAR EG40 12 16B mechanical transmission with 8 forward and 4 reverse gears powered by a 690hp Maybach HL230 P30 gasoline engine, with a top speed of 29.8 mph (41.5 km/h). The crew of 5 consisted of the tank commander, the loader, the driver, and the radio operator. The only other variant of the King Tiger was the Hunting Tiger, or Jagdtiger. With the exception of the initial prototype, all King Tigers were coated with Zimmerit until September 11, 1944.

The King Tiger dominated the battlefield in terms of capabilities, but often suffered from shortages of lubricants & fuels. These tanks proved themselves in battles ranging from Normandy, the Ardennes, Lake Balaton, and Berlin. Although they lived up to the expectations of the 'Wundenwaffe', the King Tigers were ineffective in stopping the overwhelming numbers of opponents they faced on the battlefield. Today there are a total of 11 King Tigers preserved around the world, with the rest having been long lost to the scrap yards.

This new King Tiger model kit represents the ultimate in dimensional accuracy for the first time through the unique feature of scale-thickness armor and a complete interior. For the first time in 1/35 scale we can appreciate the full experience inside this infamous tank, from the driver & radio operator in the fighting compartment to the loader, gunner, and commander in the turret, as well as the engine compartment complete with Maybach engine. Every detail inside & out was painstakingly measured from a surviving vehicle from s SS Pz.Abt.501 abandoned by German troops in 1944 during the Battle of the Bulge, currently in storage at the U.S. Armor & Cavalry Museum at Ft. Benning, Georgia. In addition, the remaining variants of the King Tiger were carefully researched and are included in our collection as well.

READ BEFORE ASSEMBLY

CAUTION

- Read carefully and fully understand the instructions before commencing assembly. A supervising adult should also read the instructions if a child assembles the model.
- When assembling this kit, tools including knives used. Extra care should be taken to avoid personal injury.
- Keep out of reach of small children. Children must not be allowed to suck any part, or pull vinyl bag over their heads.



Optional

Instant Glue
for Metal

Apply Decal



Drill Do Not Cement Remove

Color info and profiles by Mig Jimenez

A.MIG.014	Rotbraun	A.MIG.035	Dark Tracks	A.MIG.037	New Wood	A.MIG.015	Schleibbraun
A.MIG.041	Dark Rust	A.MIG.045	Gun Metal	A.MIG.052	Oilingrun Opt.2	A.MIG.024	Washable White Camo
				A.MIG.015	Dunkelgelb		
				A.MIG.036	Old Wood		

APPLYING DECALS

1. Clean the model surface with a wet cloth.
2. Cut out each decal design from sheet, and dip it in tepid water for 15~20 sec.
3. Hold the backing sheet edge and slide decal onto the model.
4. Move decal into position by wetting decal with finger.
5. Press decal gently down with a soft cloth until excess water and air bubbles are gone.

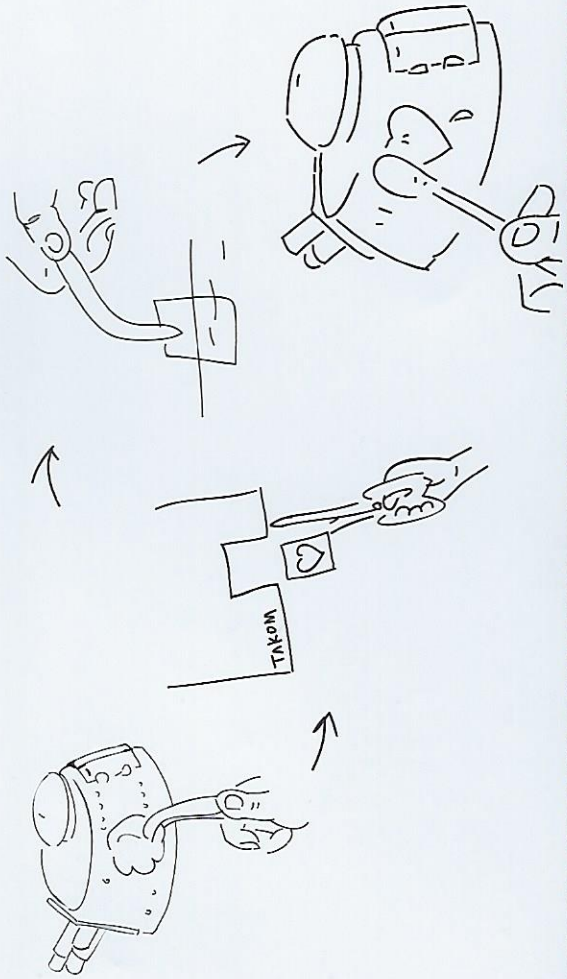

REMOVING PE

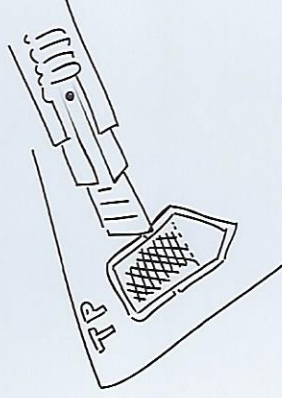

Be careful not to hurt when removing PE parts.



Secure using instant glue (not included).

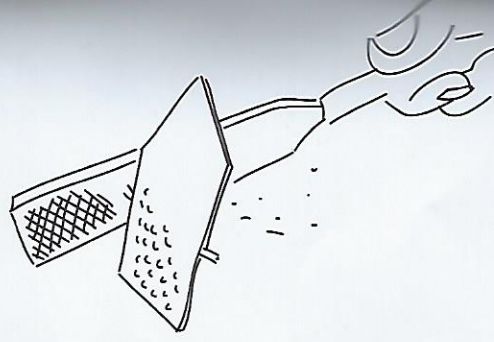

Finish using file.

PARTS

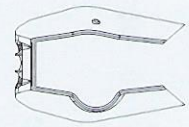
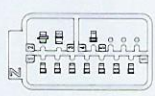
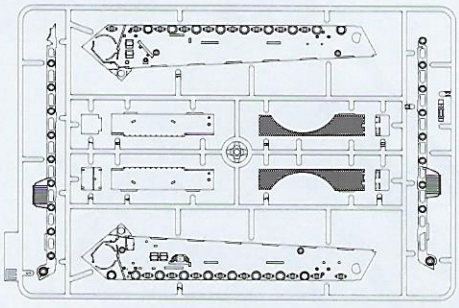
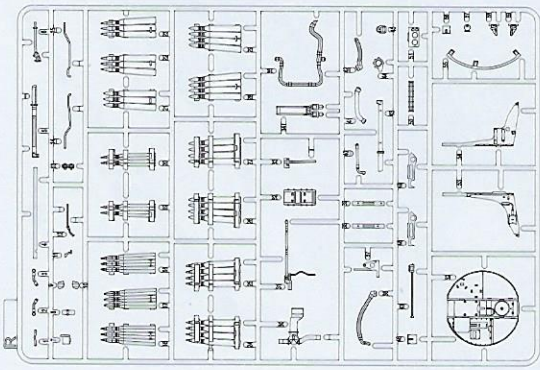
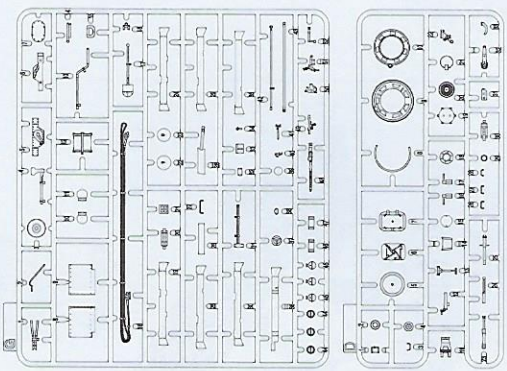
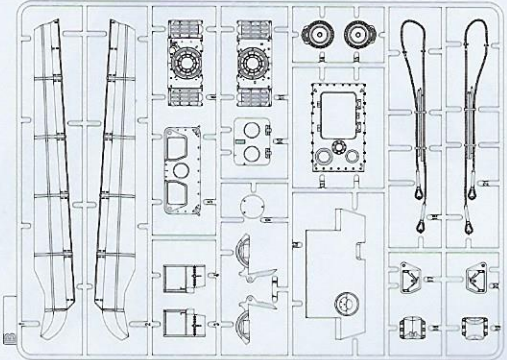
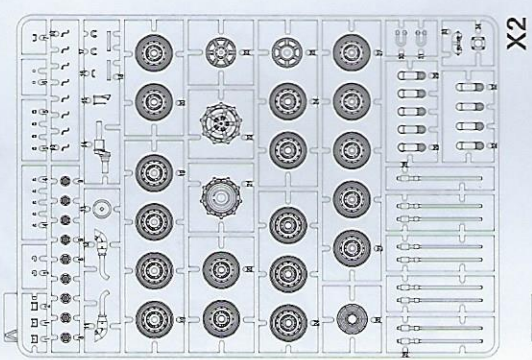

Turret

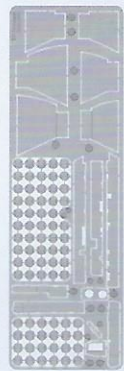
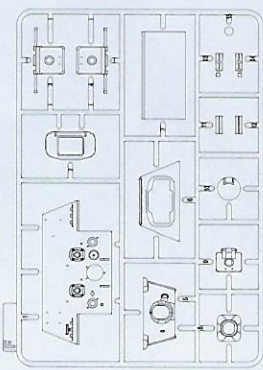
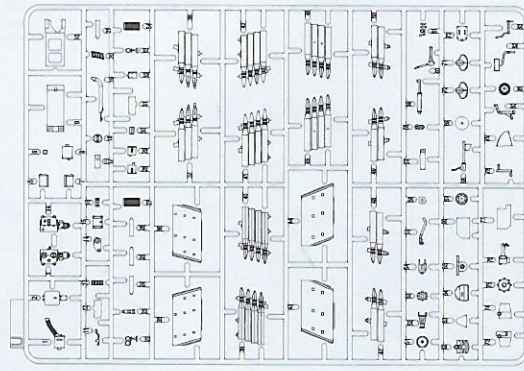
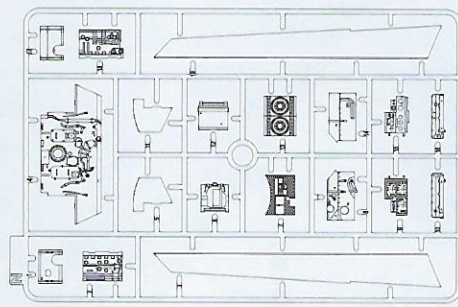
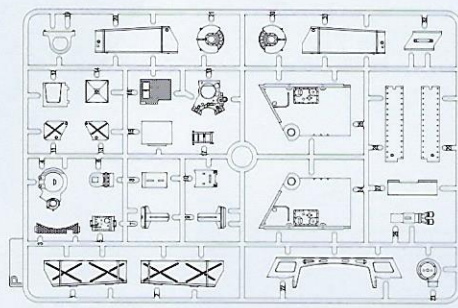
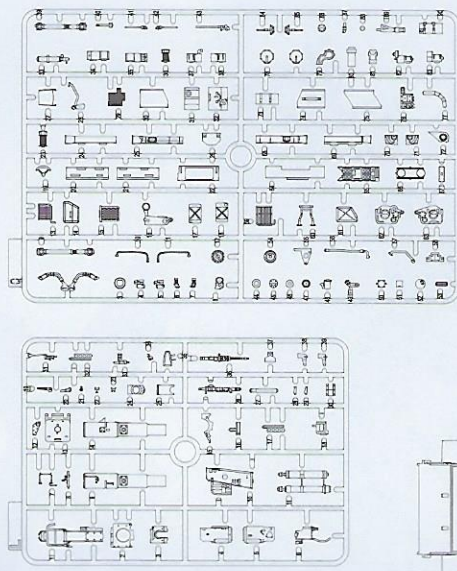
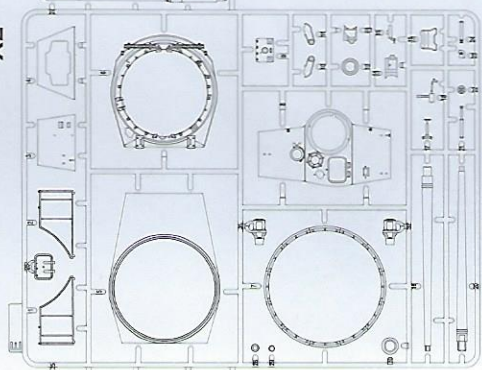

Upper Hull

Lower Hull

TP

Decal

X2

2

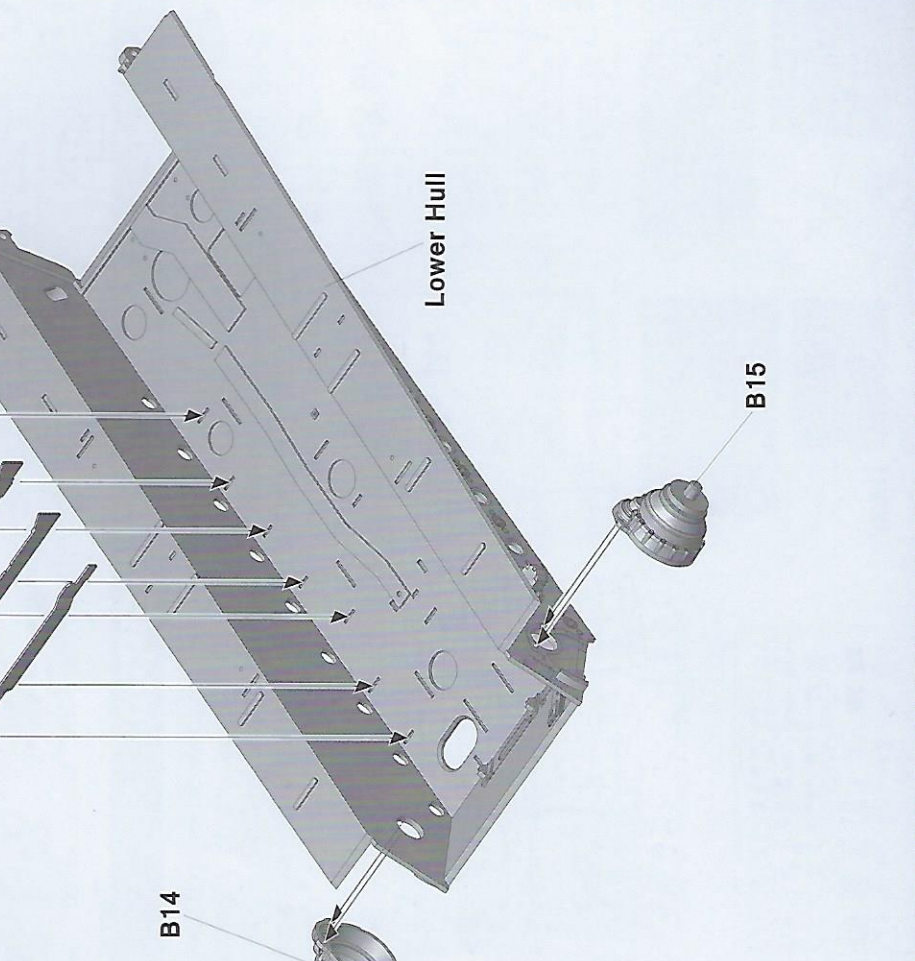
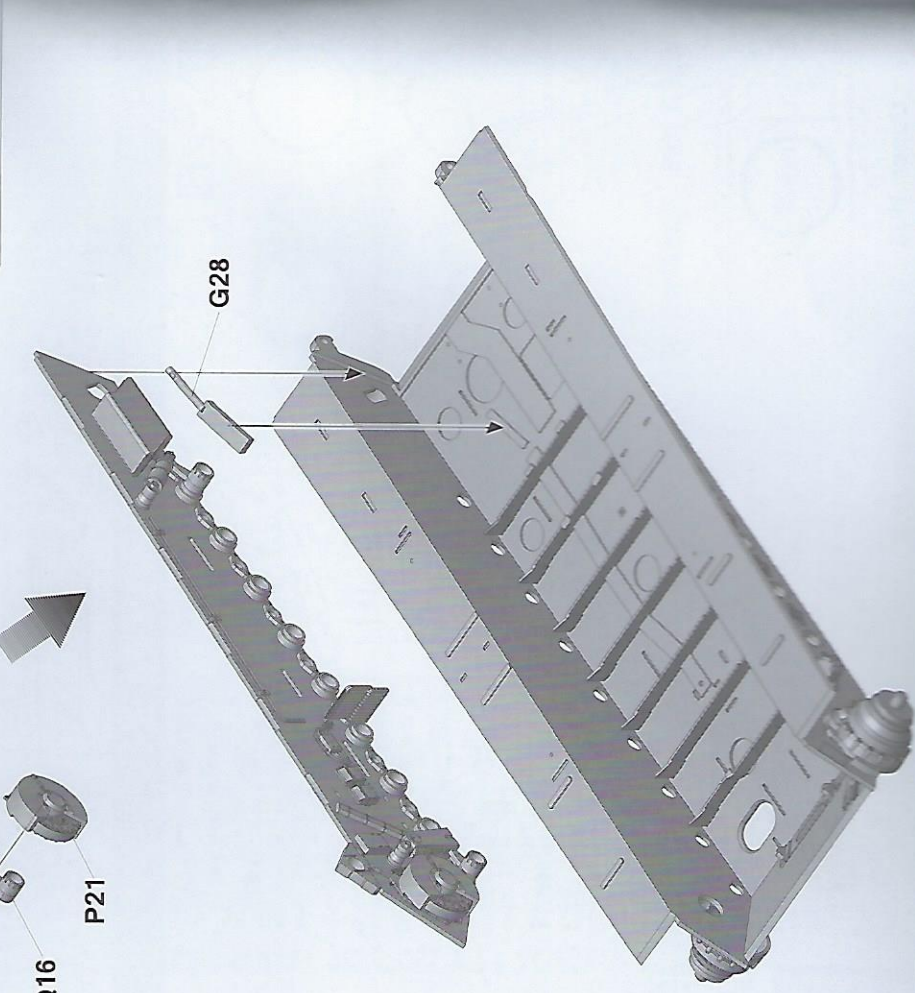
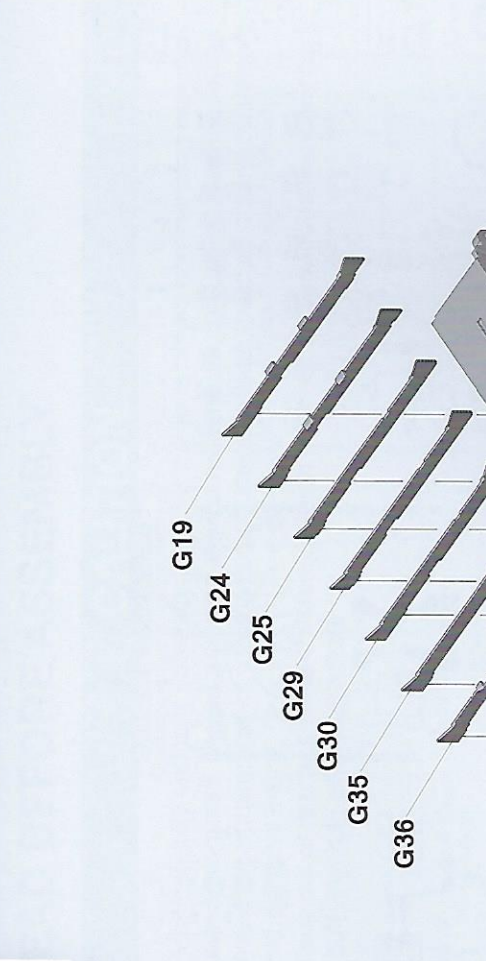
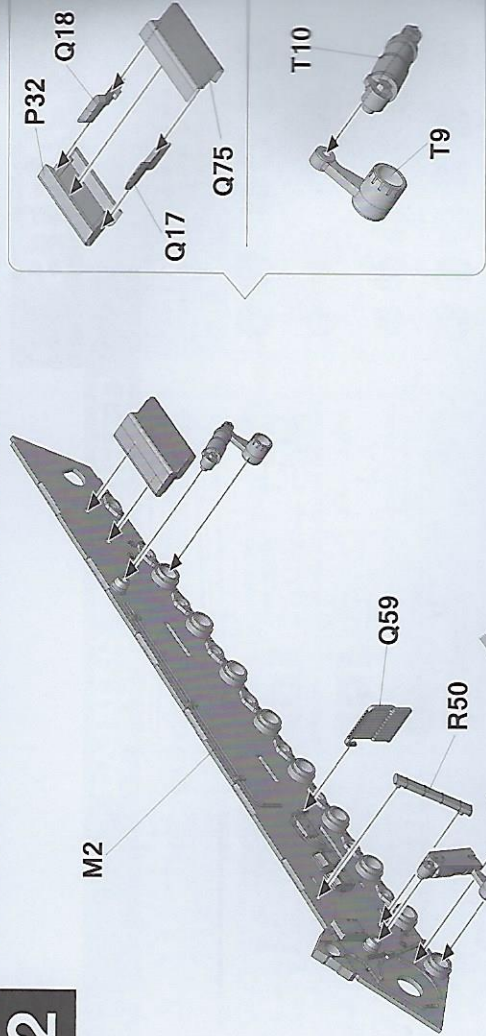

3

3

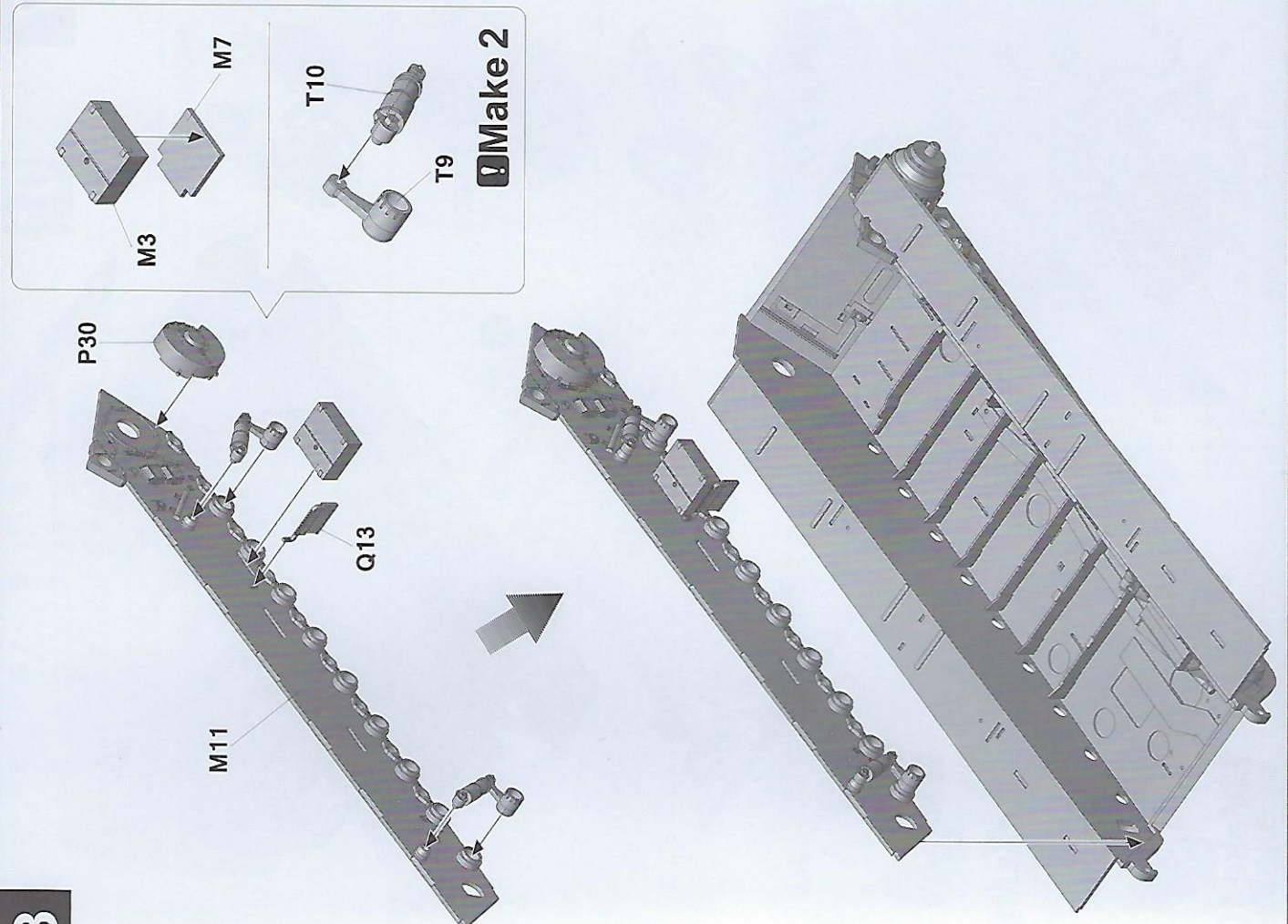

4

4

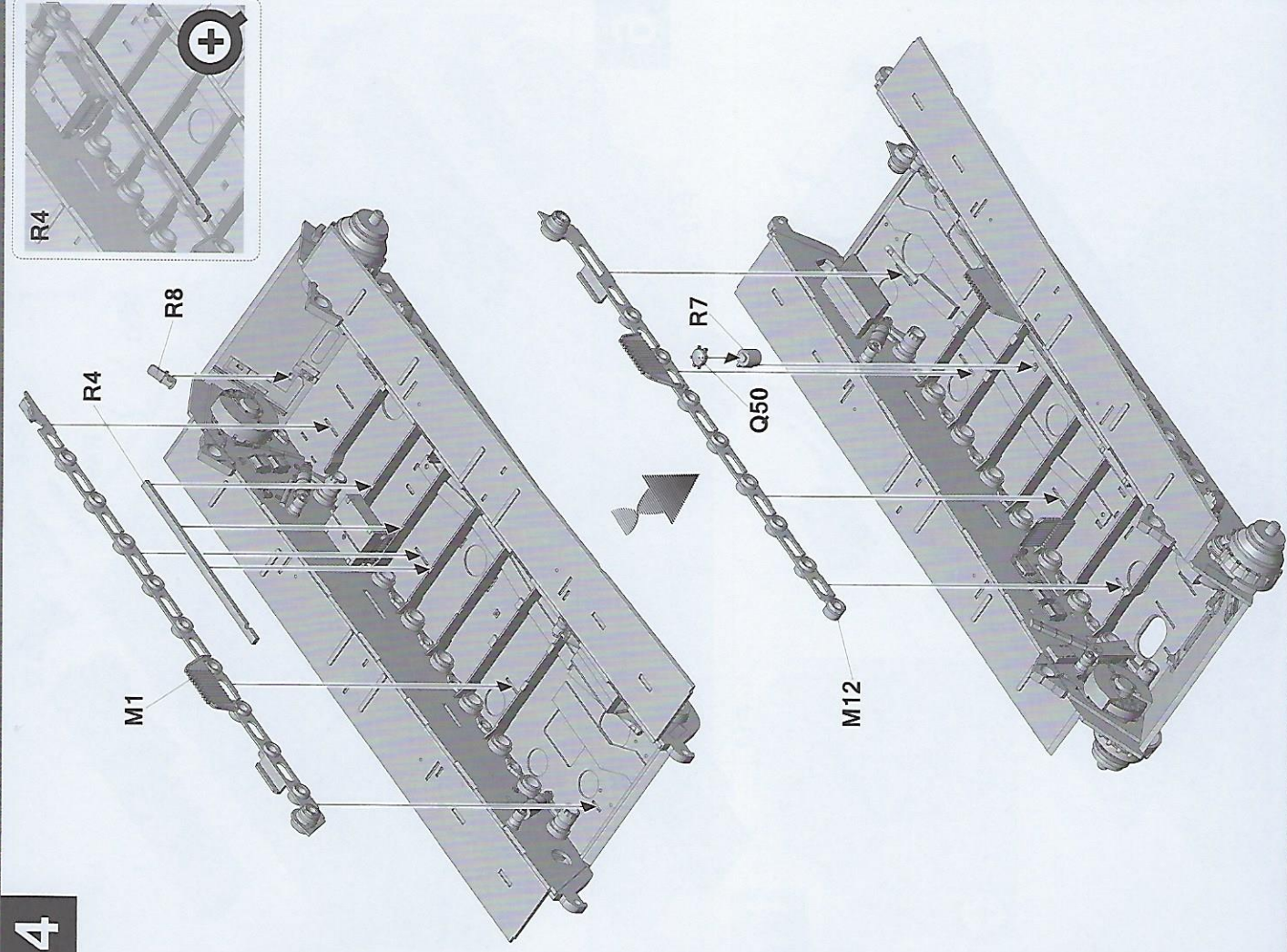

5

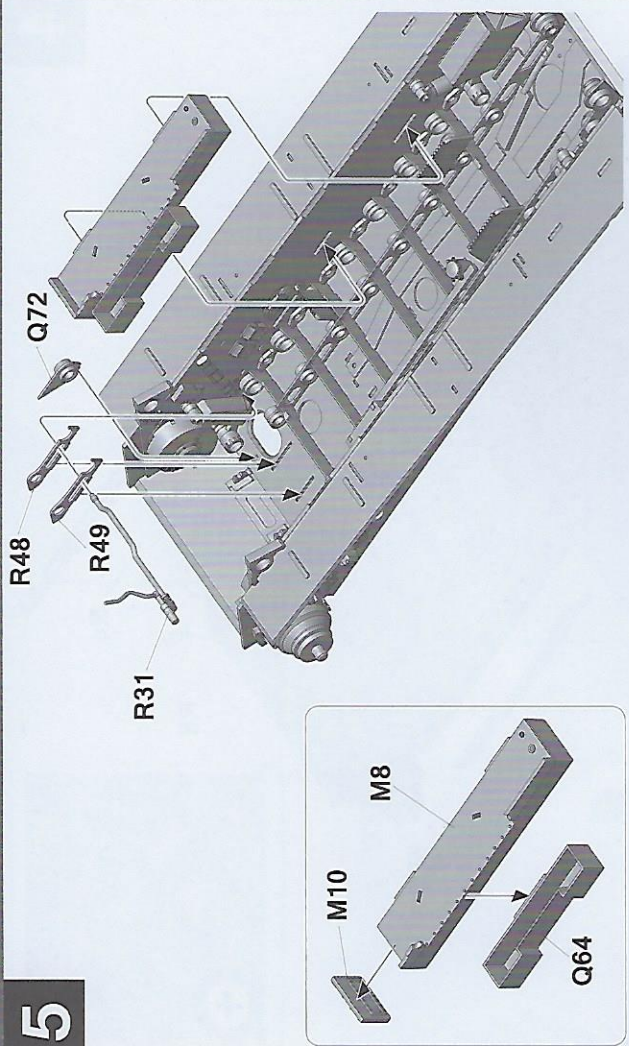

7

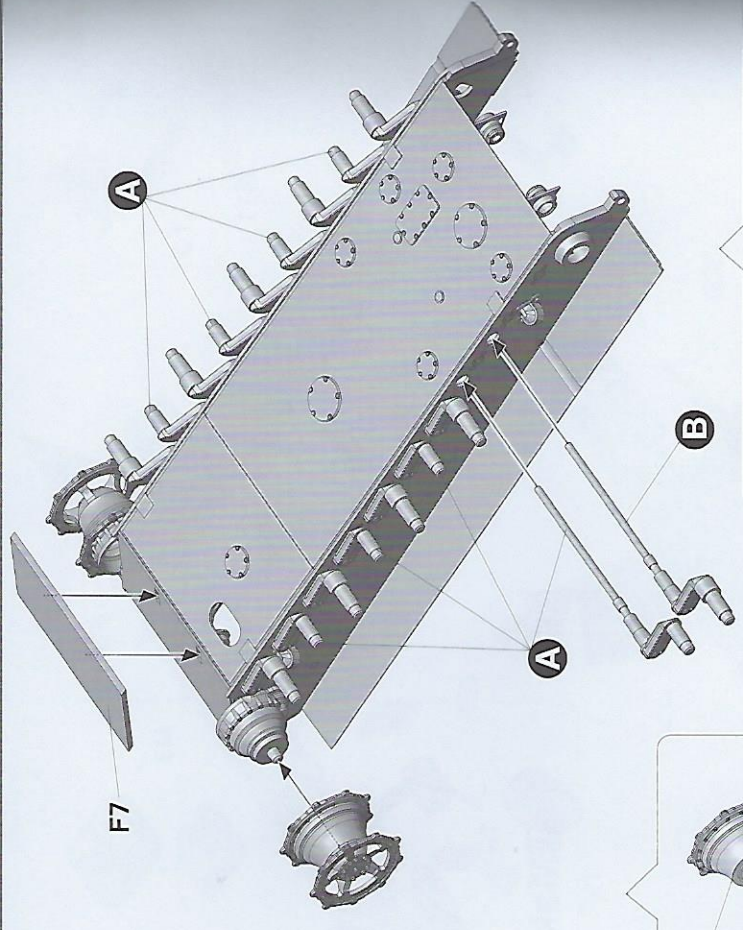

6

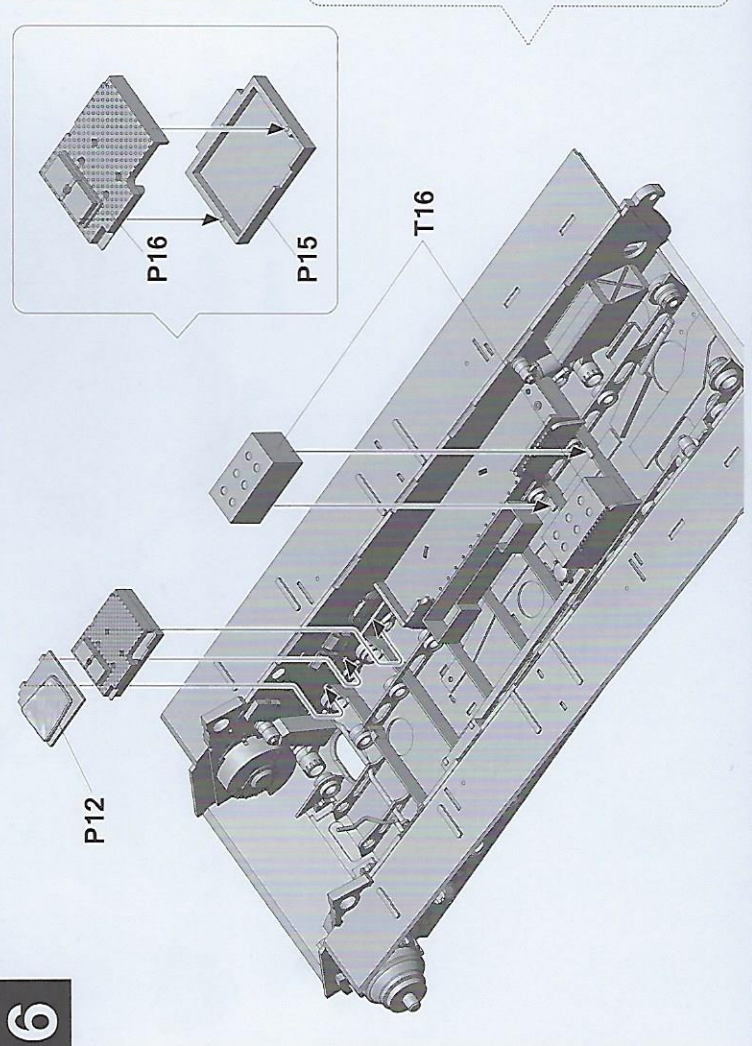

Make 2

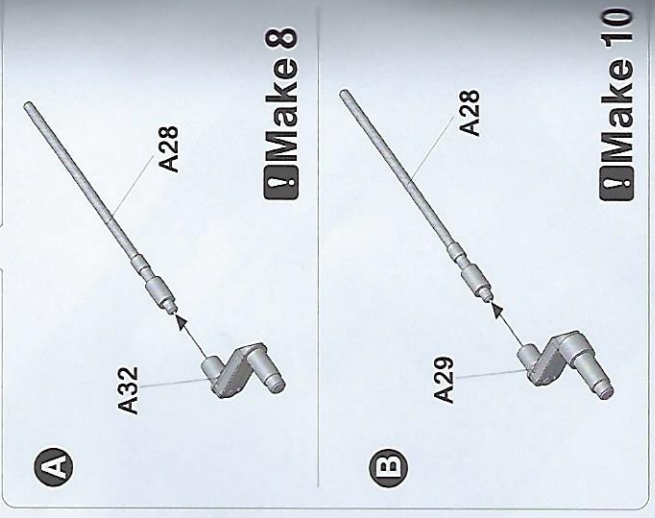

Make 8

Make 10

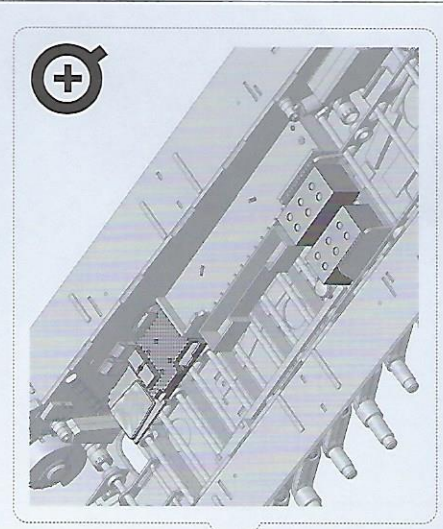

5

8

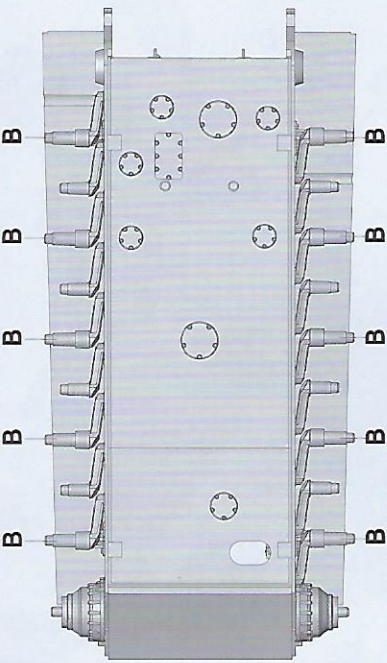

10

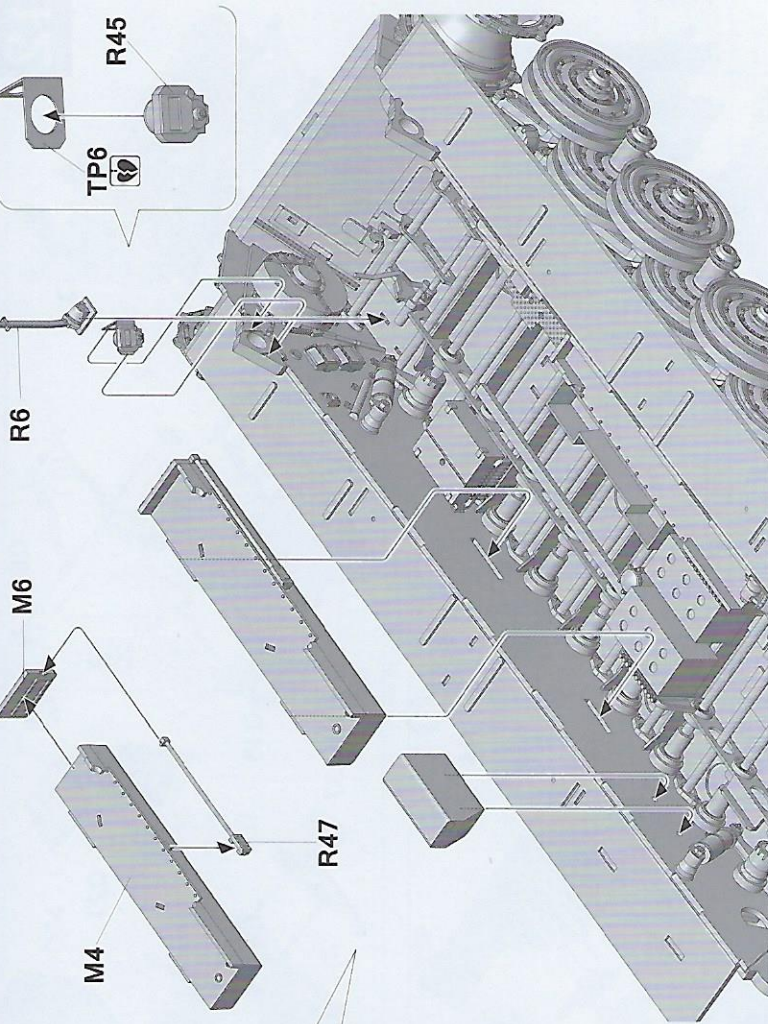
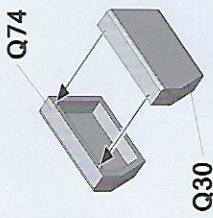

9

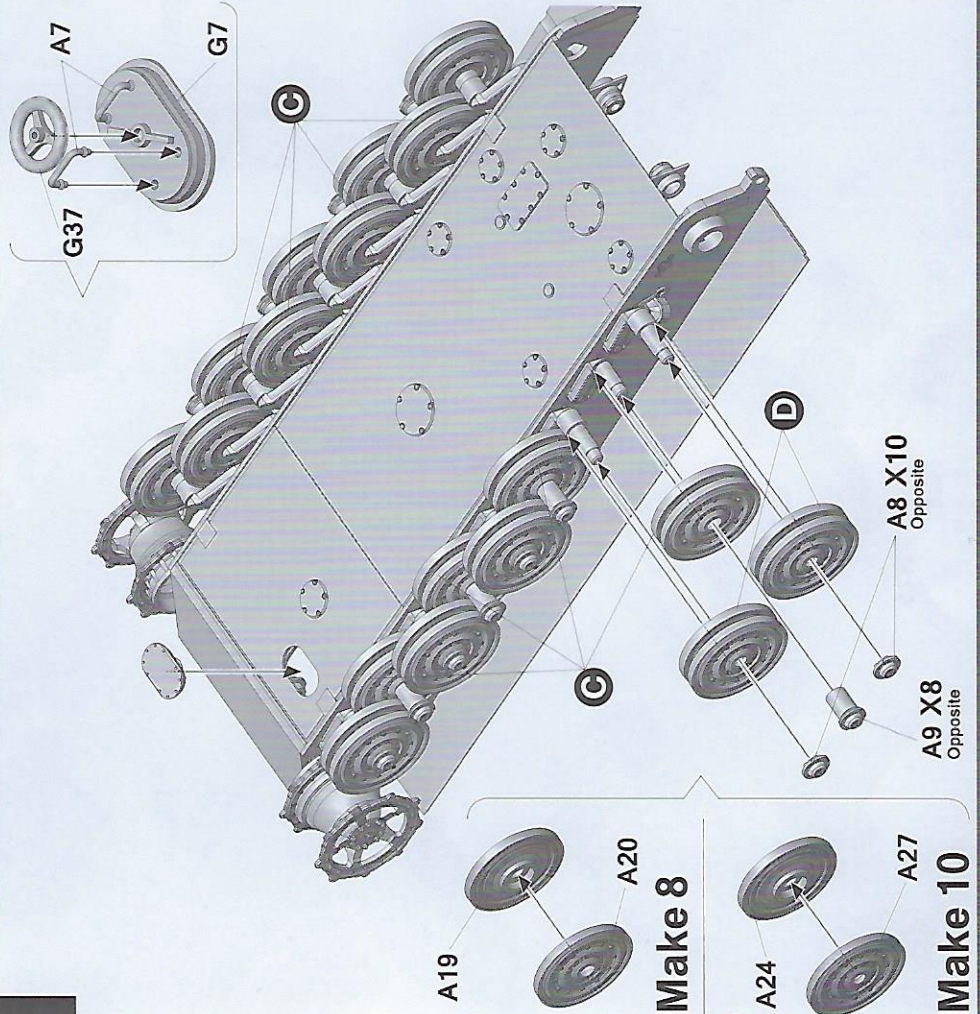

11

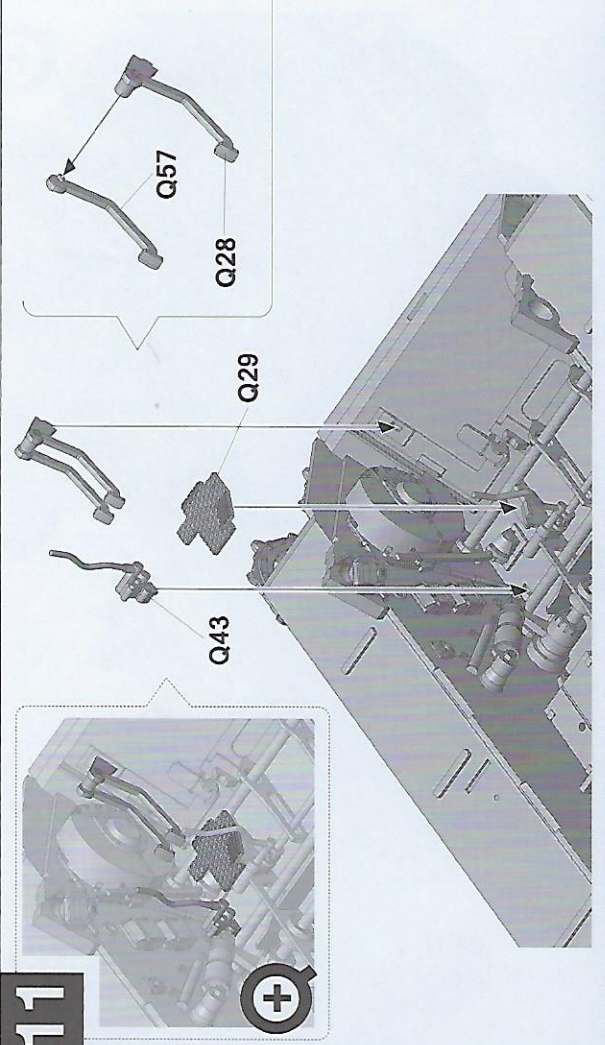

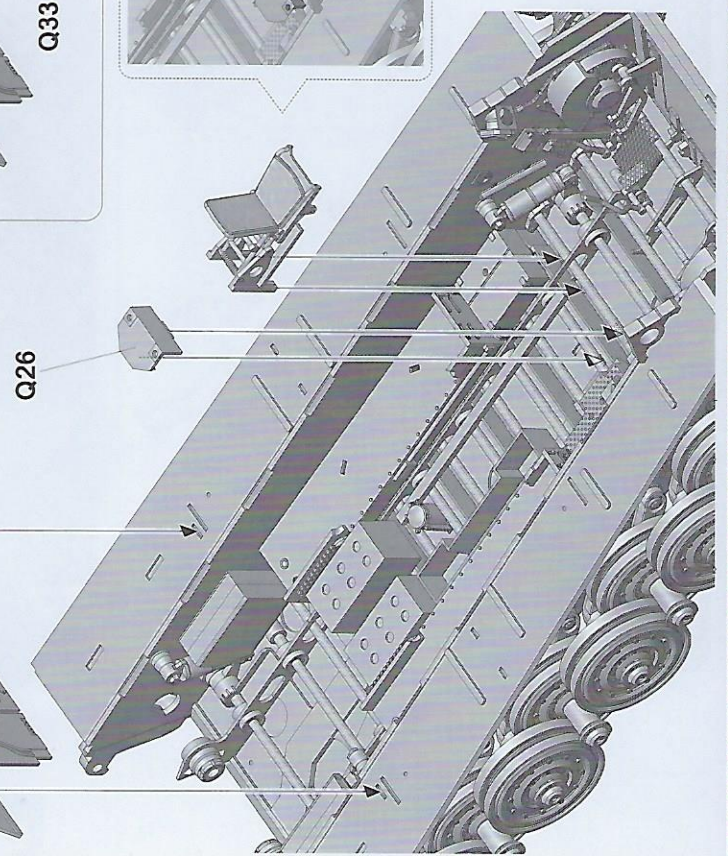
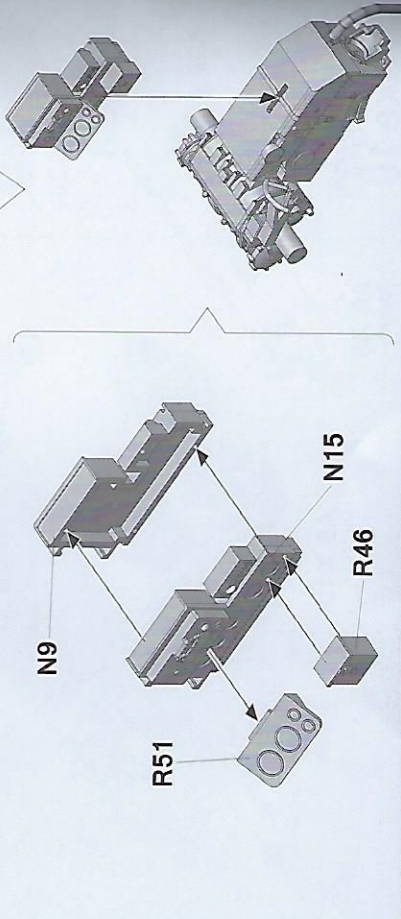
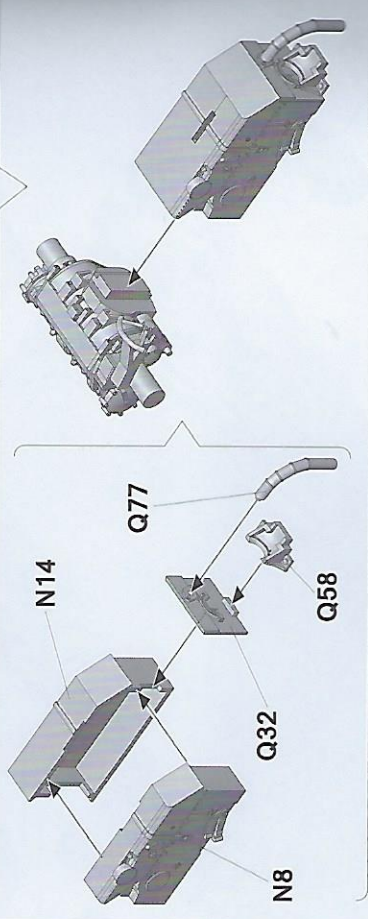
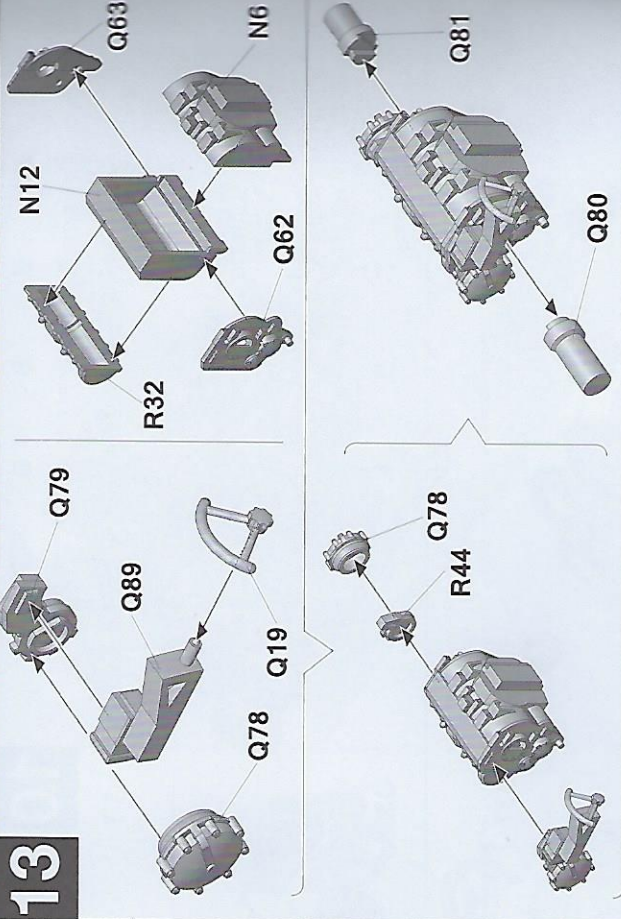
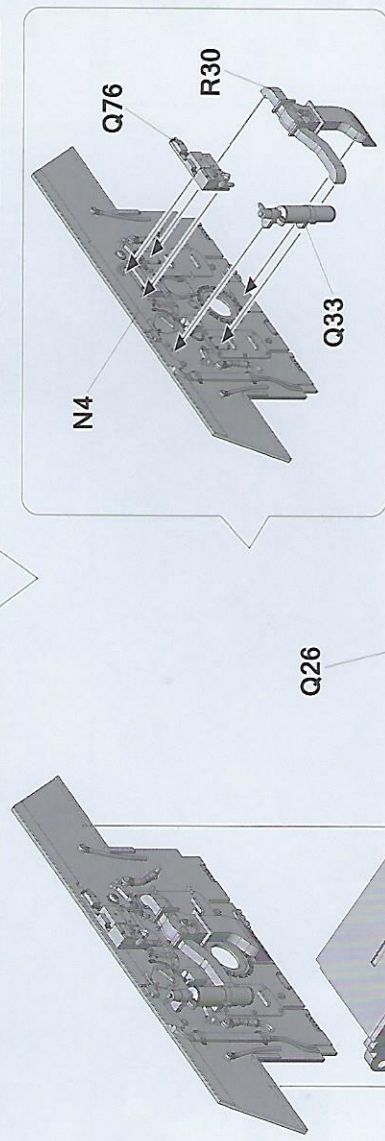
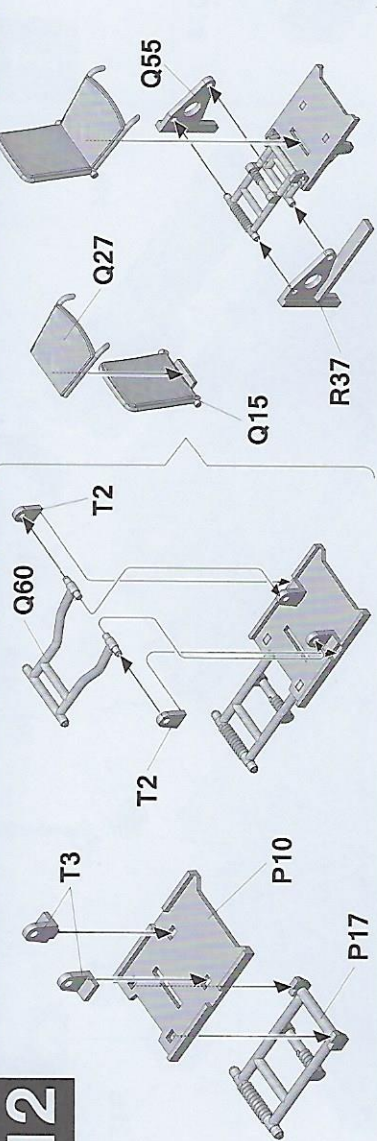

4

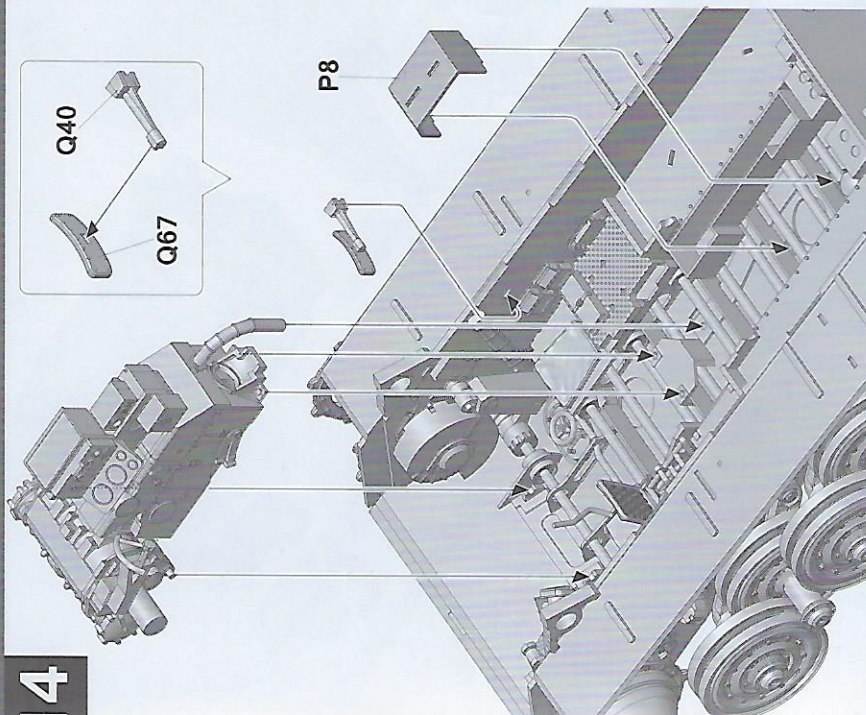

15

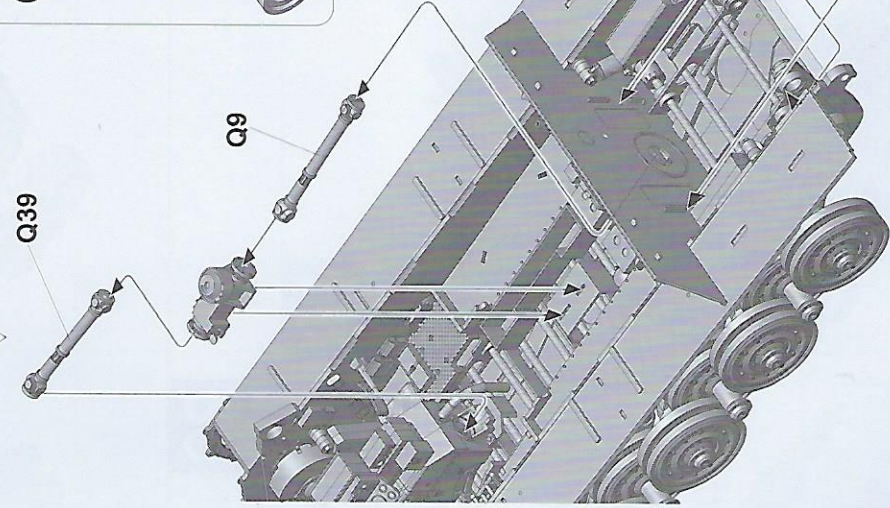
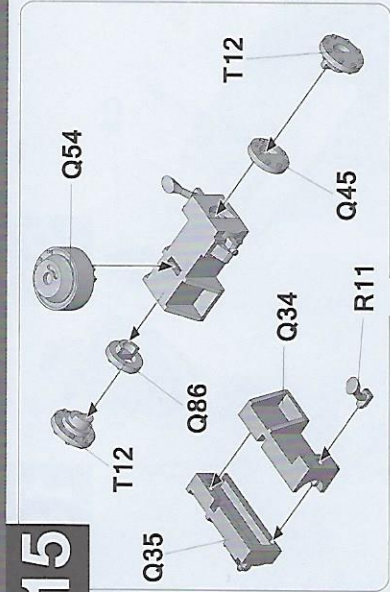

6

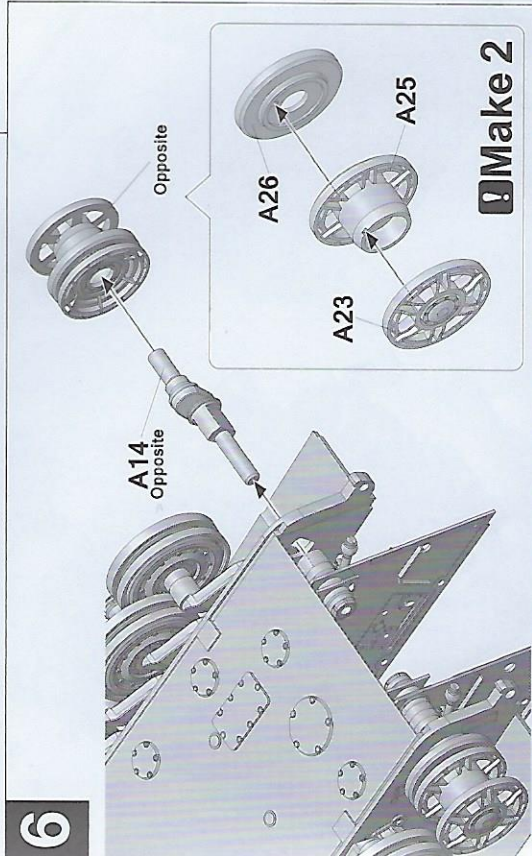

Make 2

A

T8

T14



P25

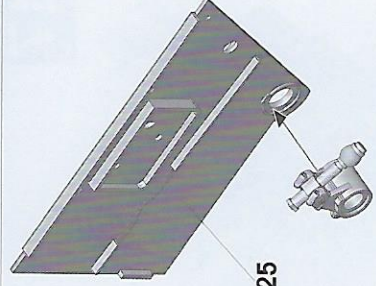

B

T8

T13

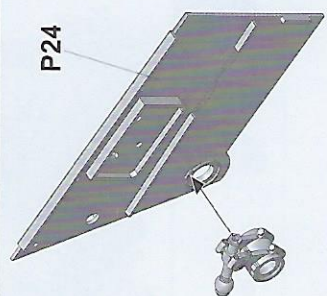

A

B

7

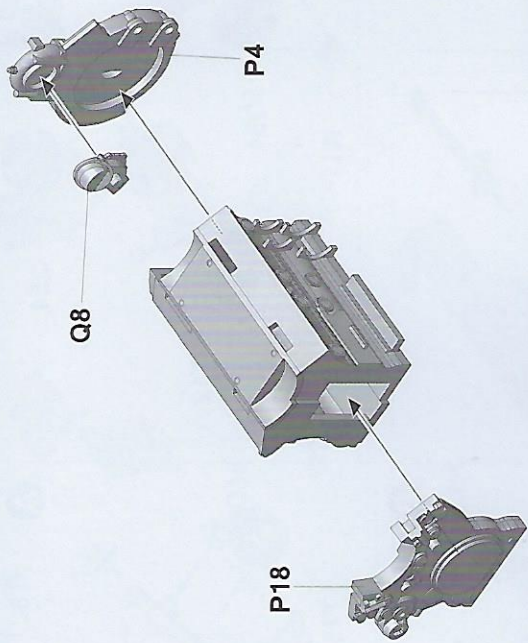
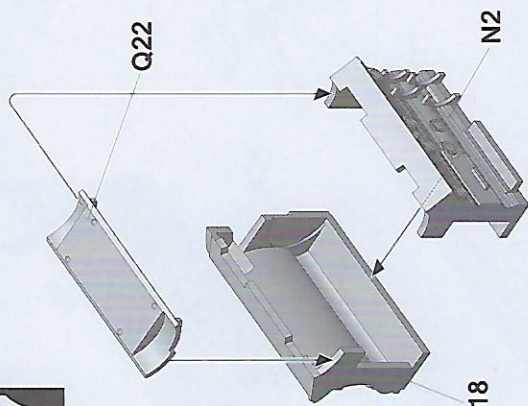

18

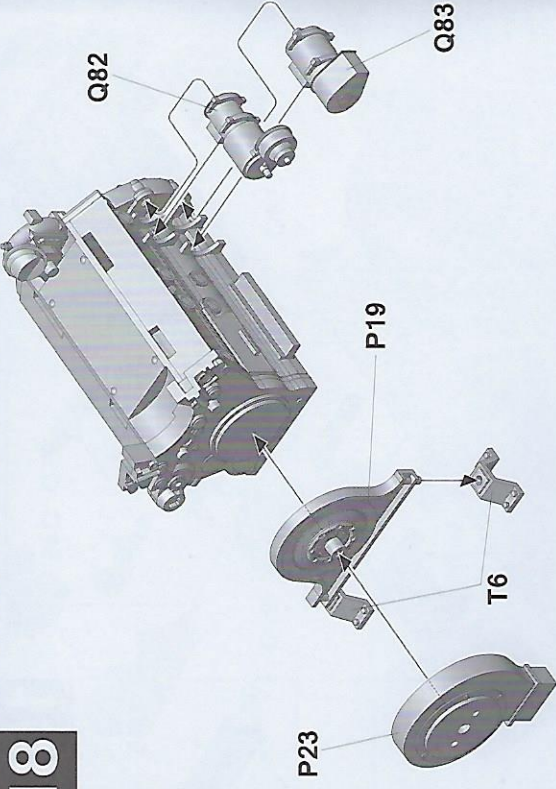

9

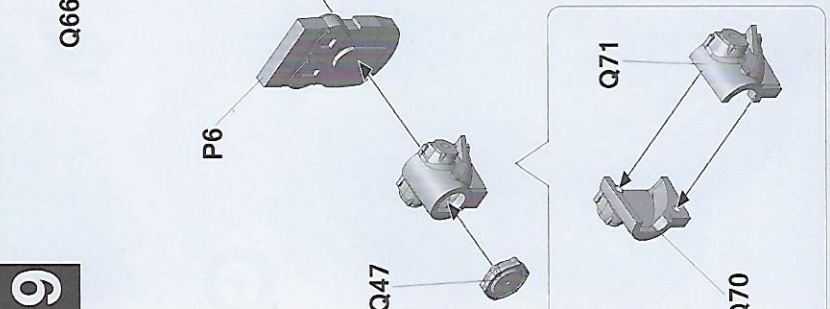

20

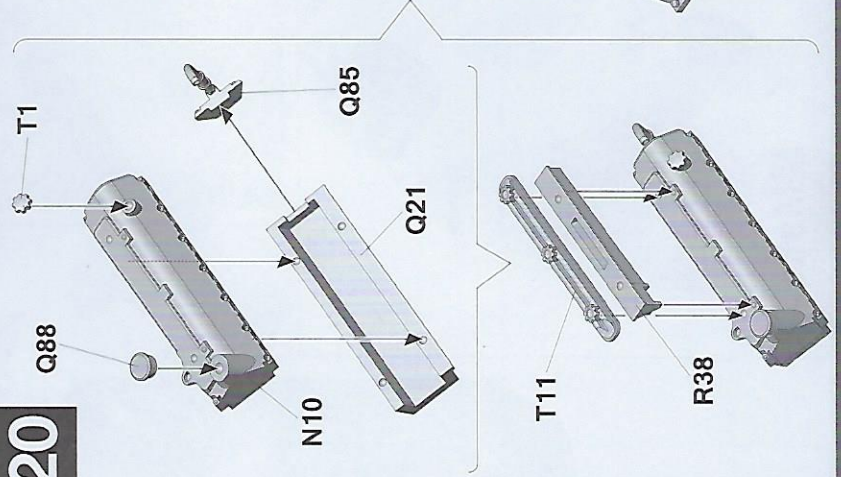
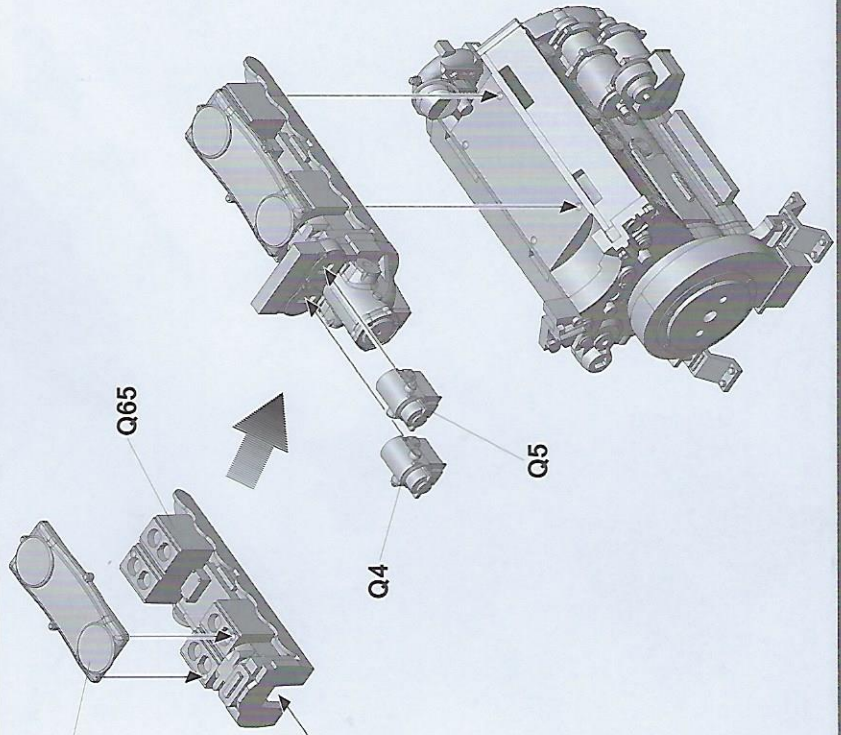

9

21

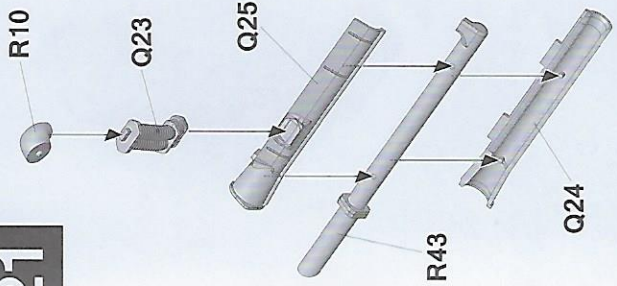

22

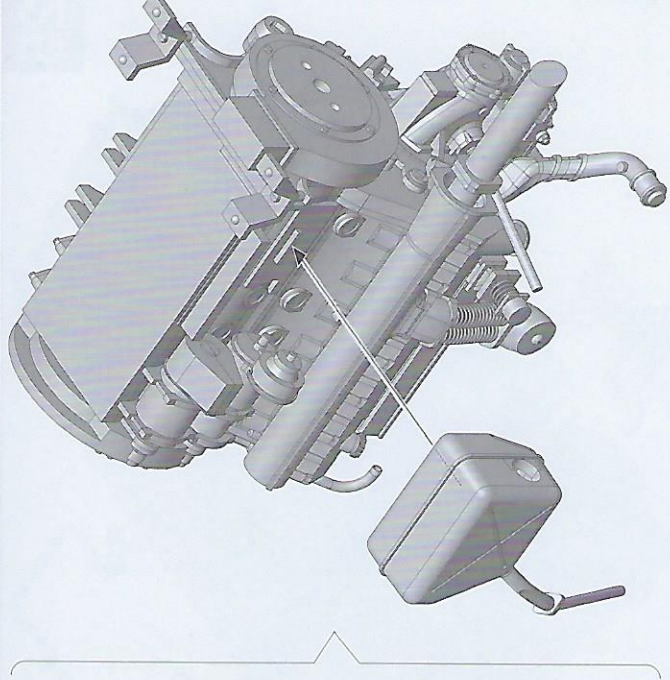
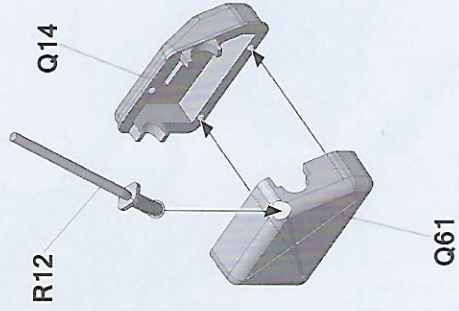

23

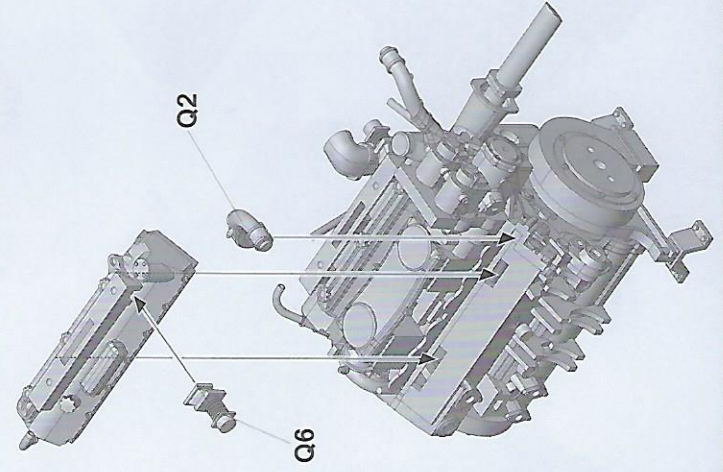
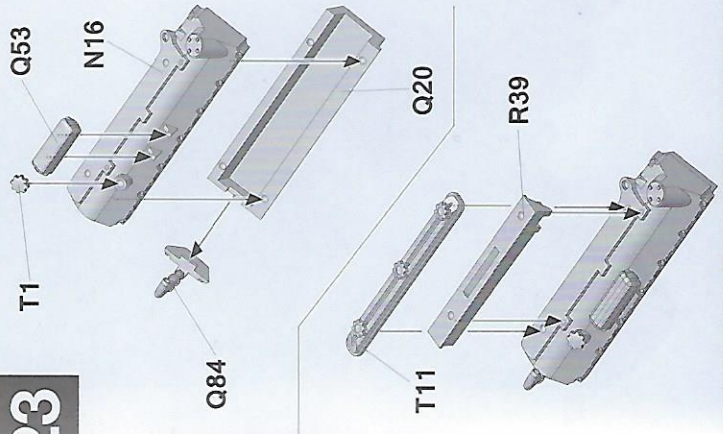

24

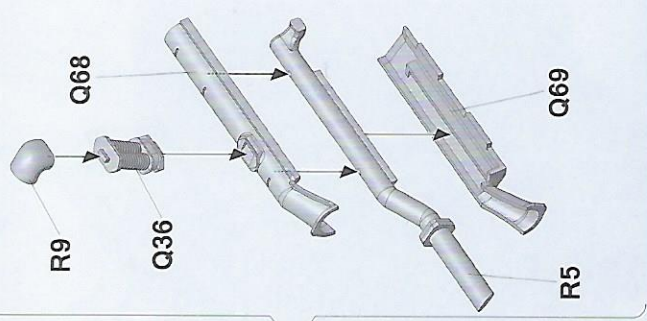
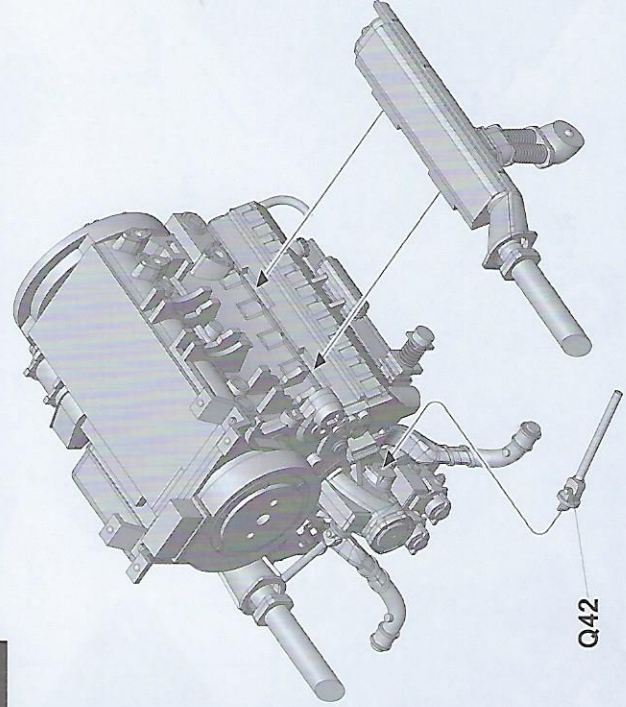

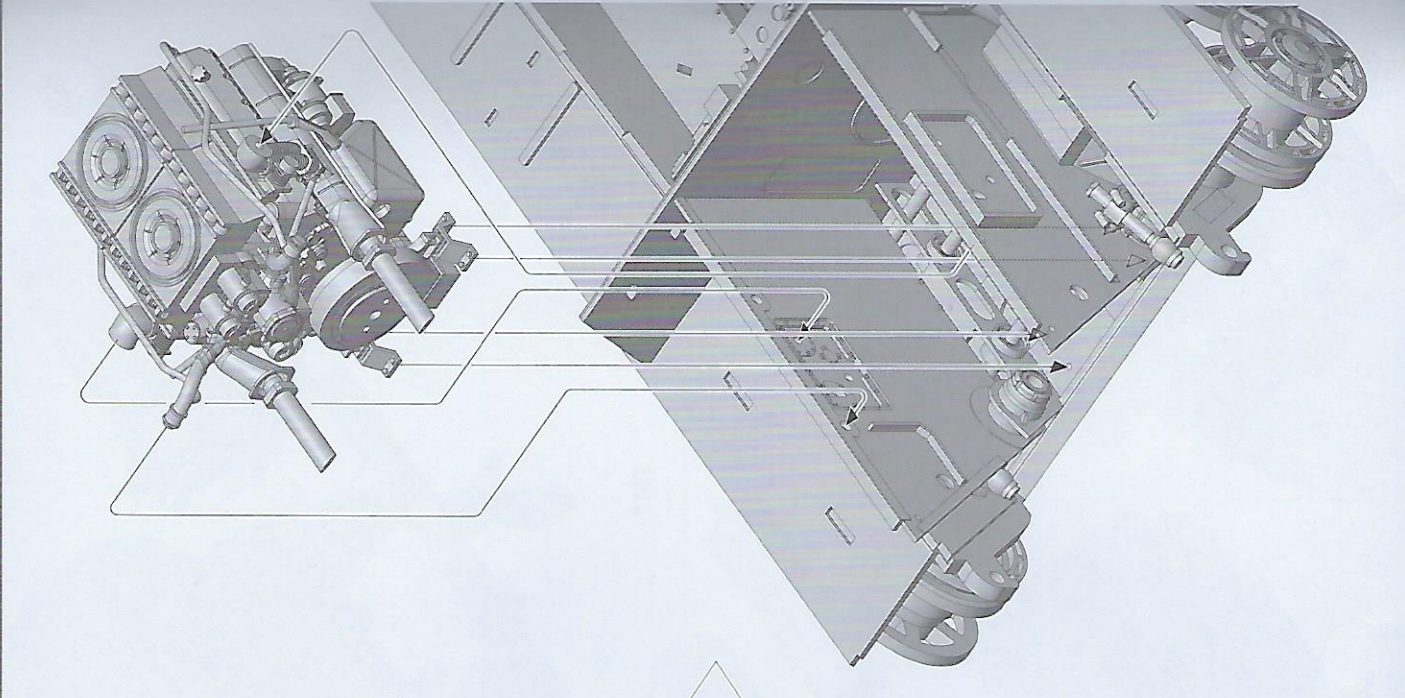
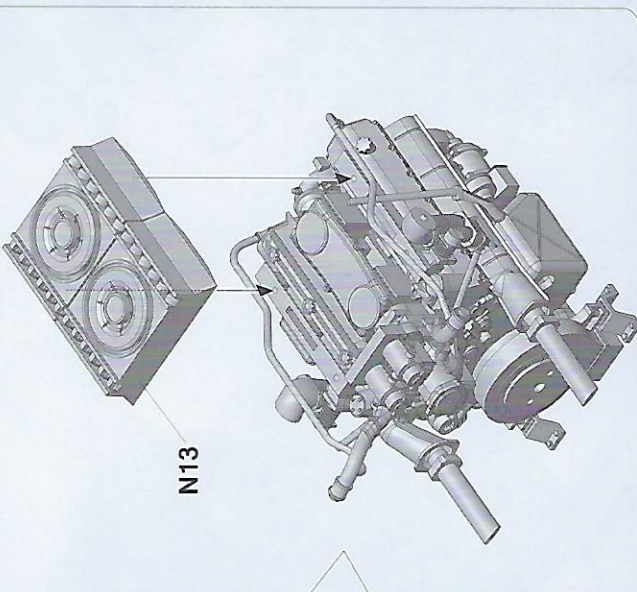
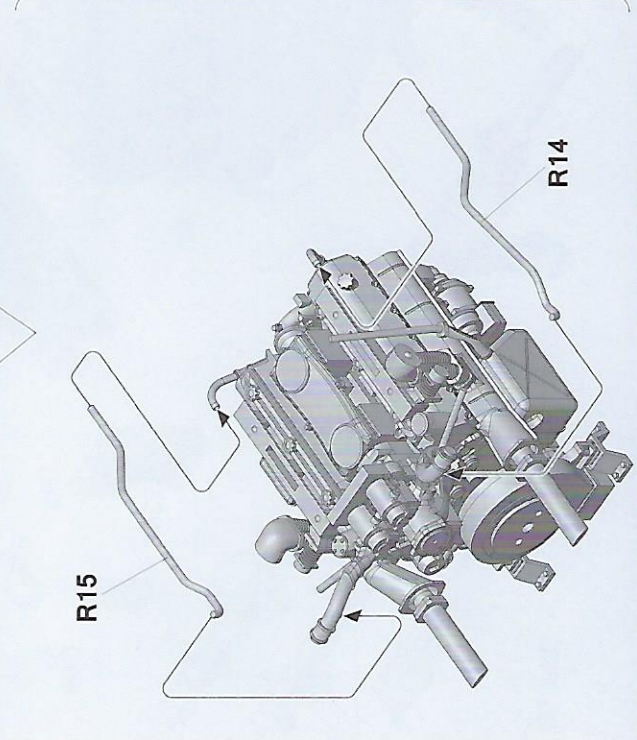
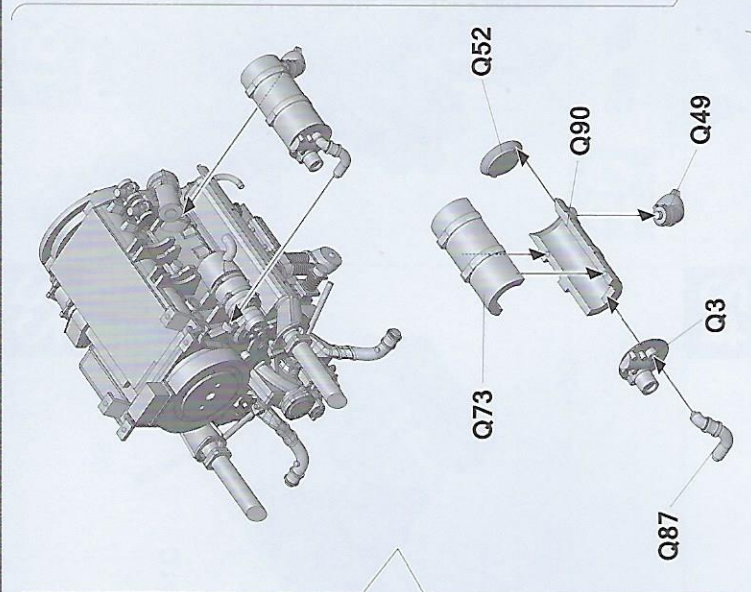
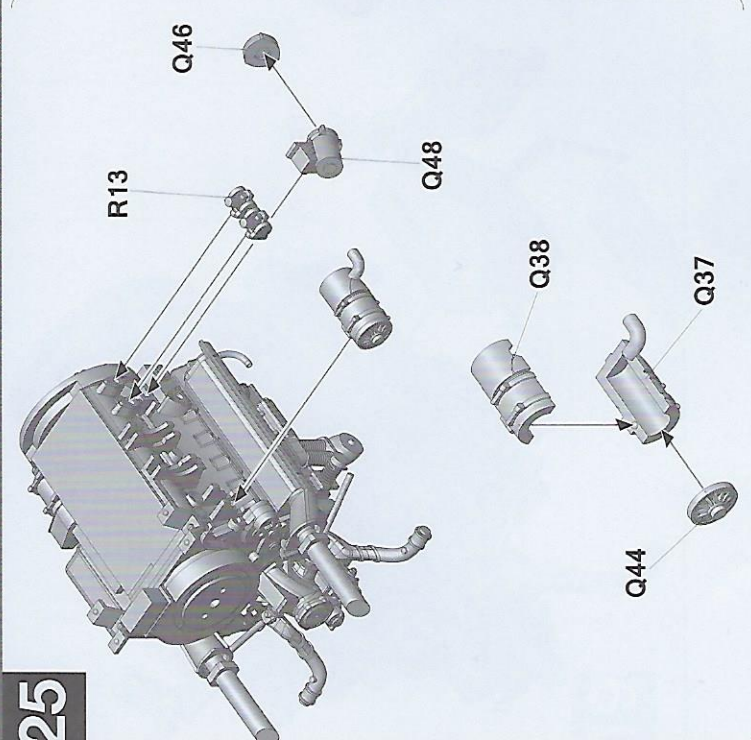

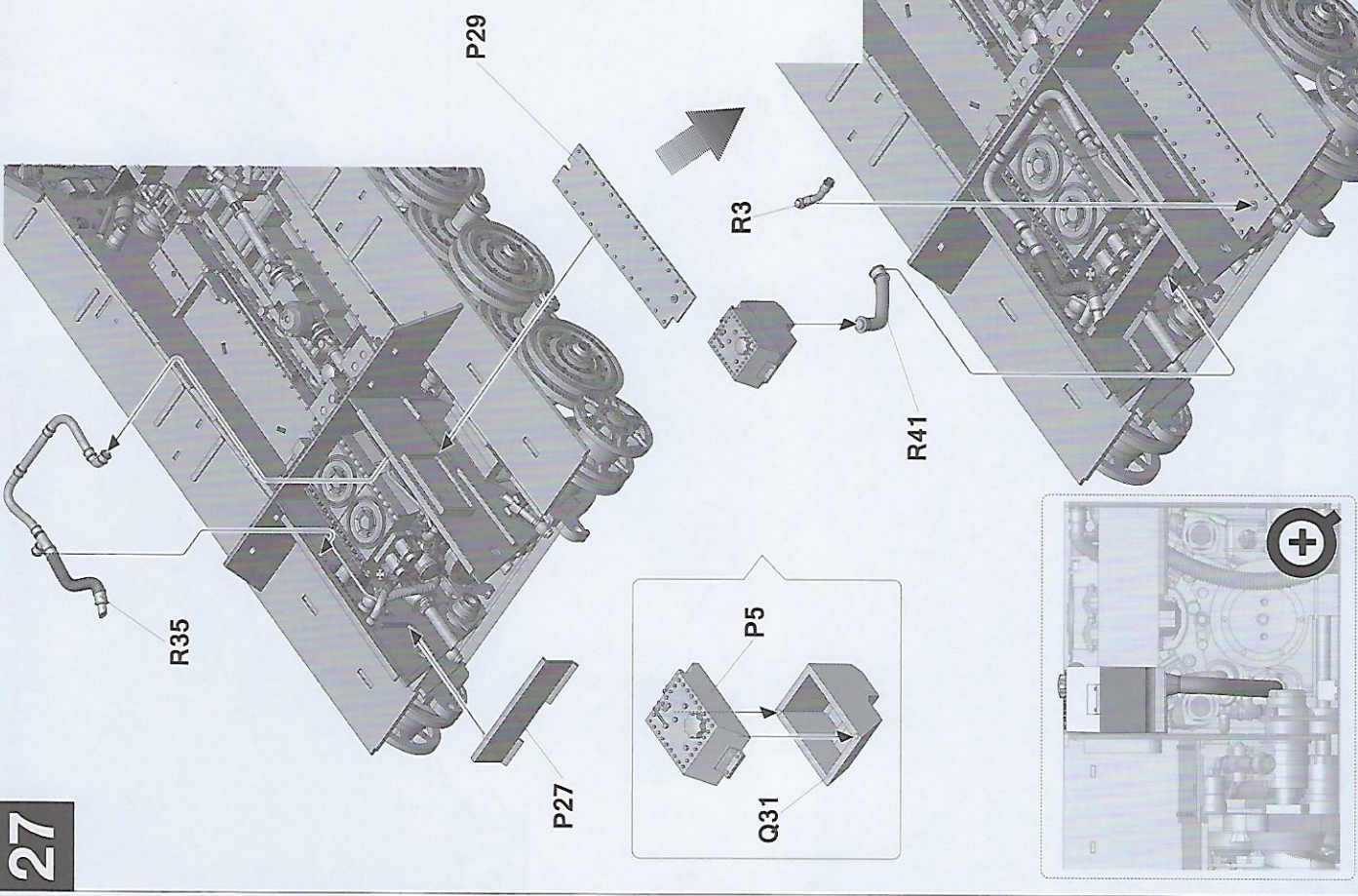
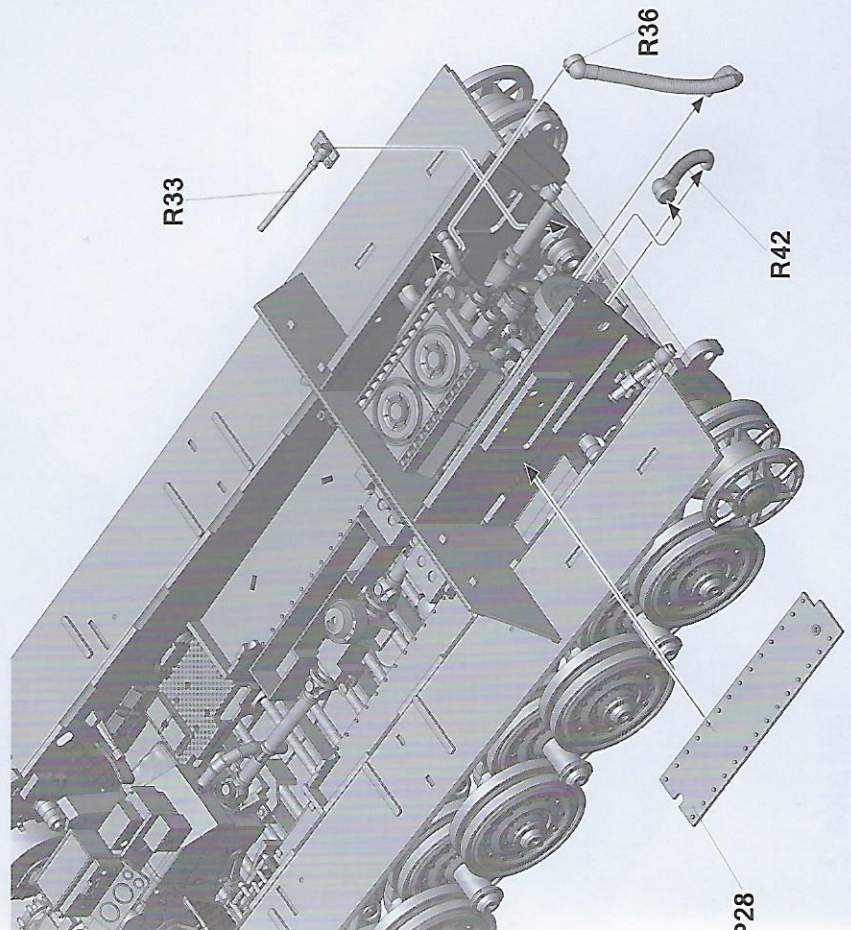
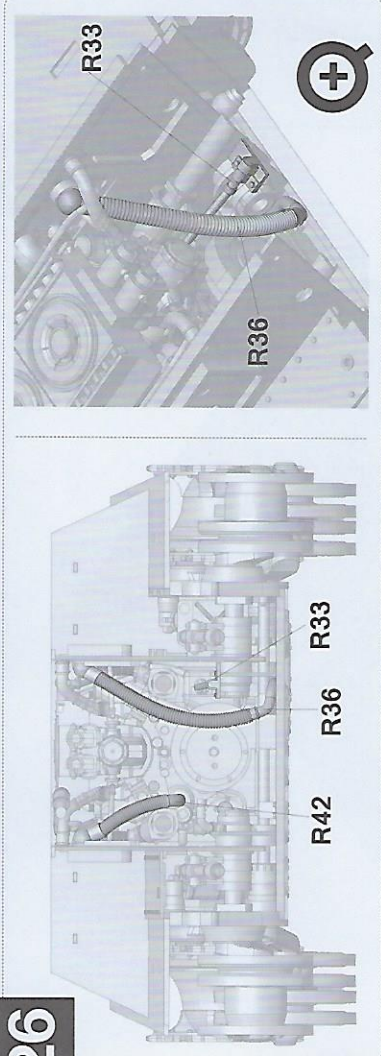

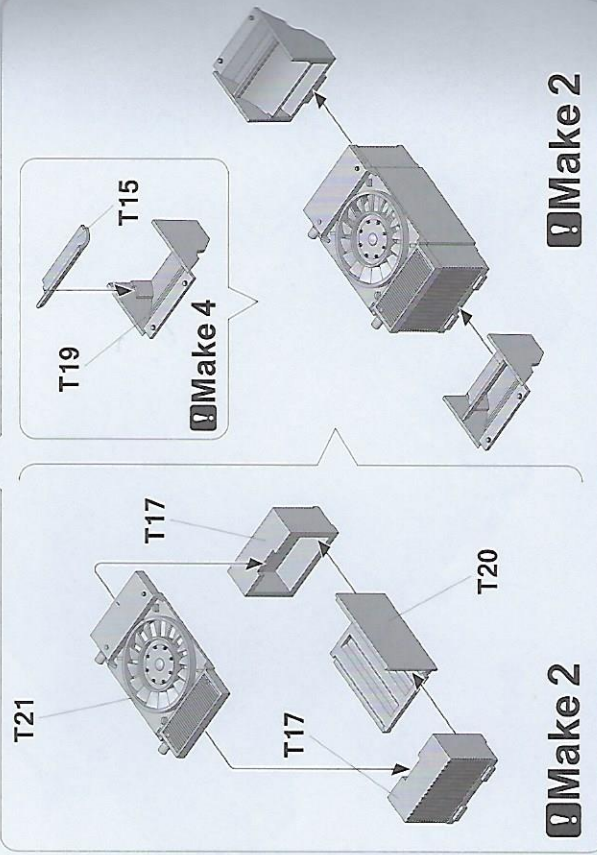
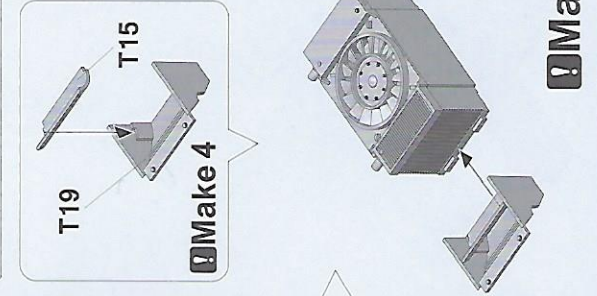
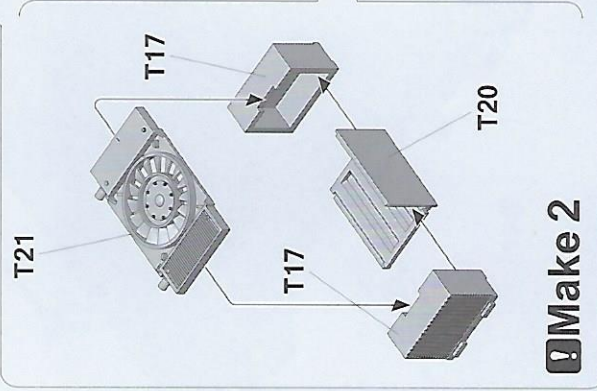
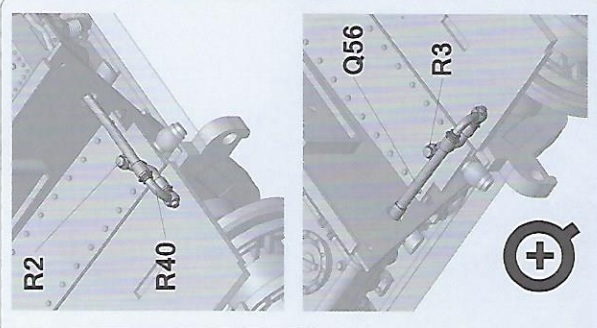
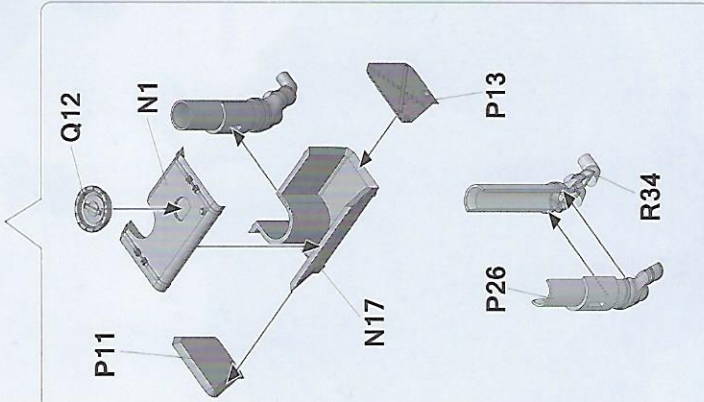
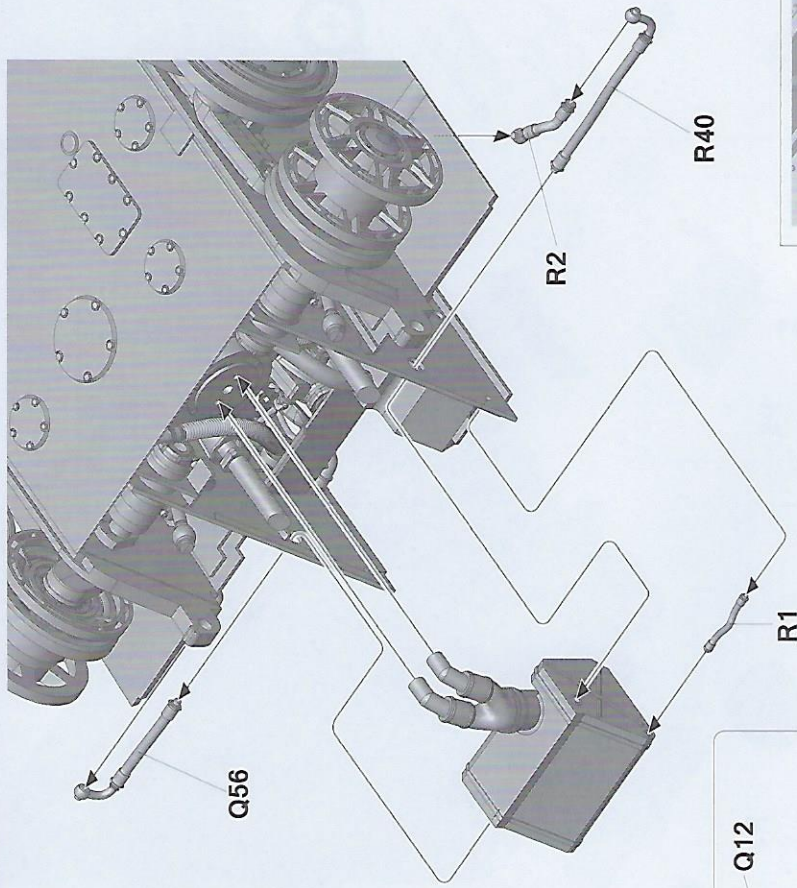

Make 2

Make 2

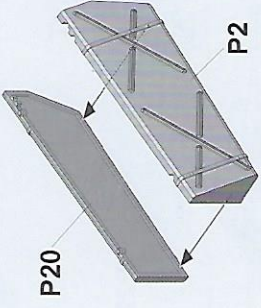
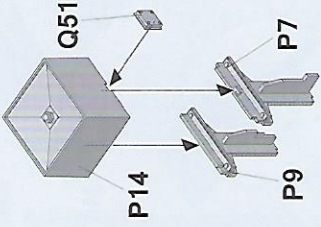
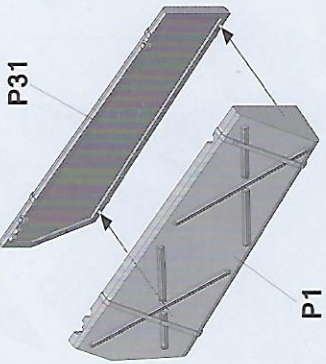

30

31

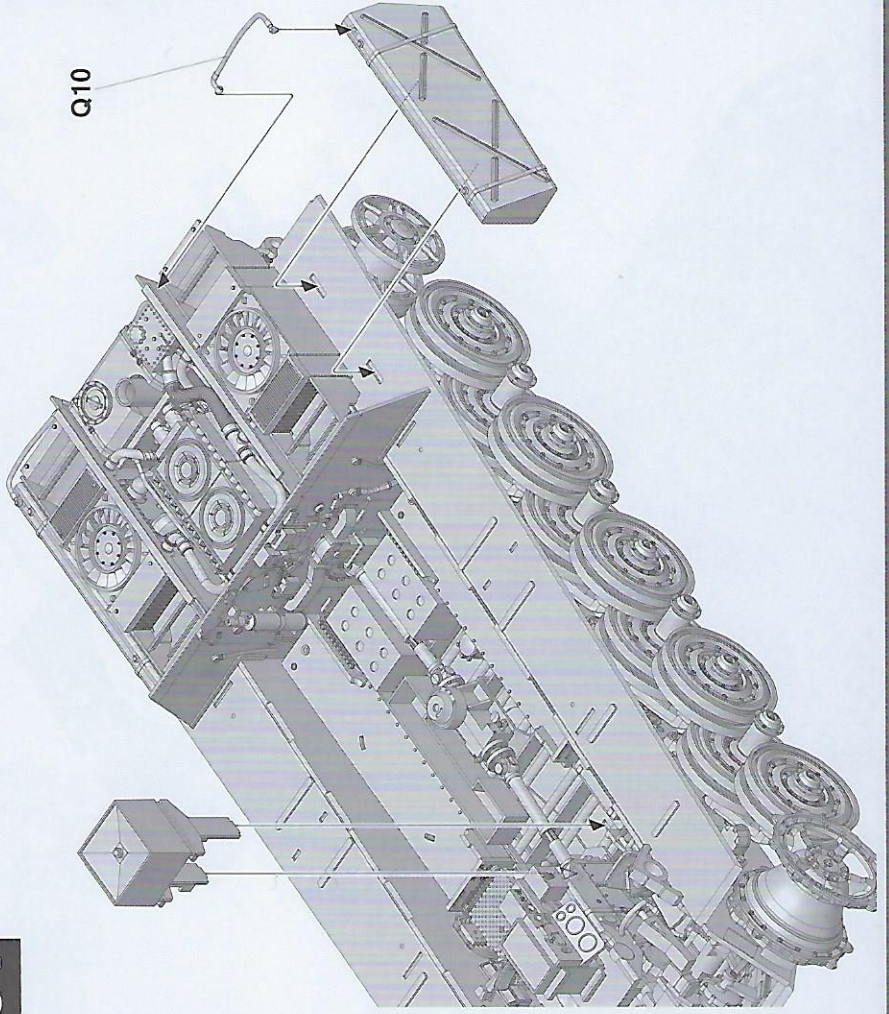
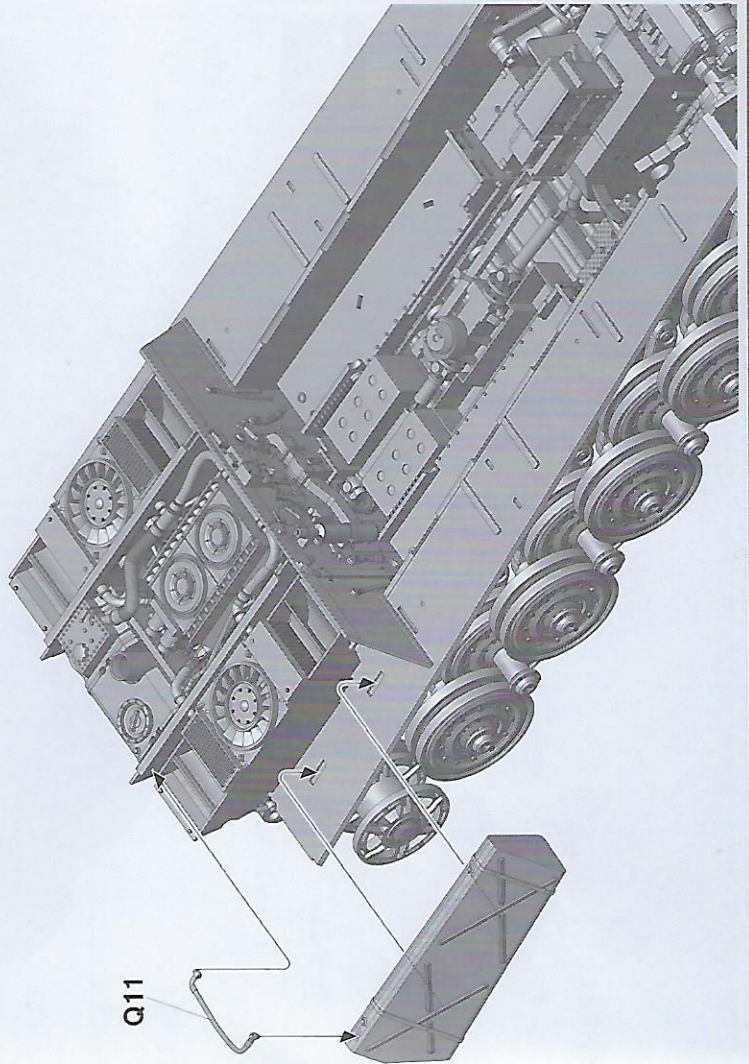

32

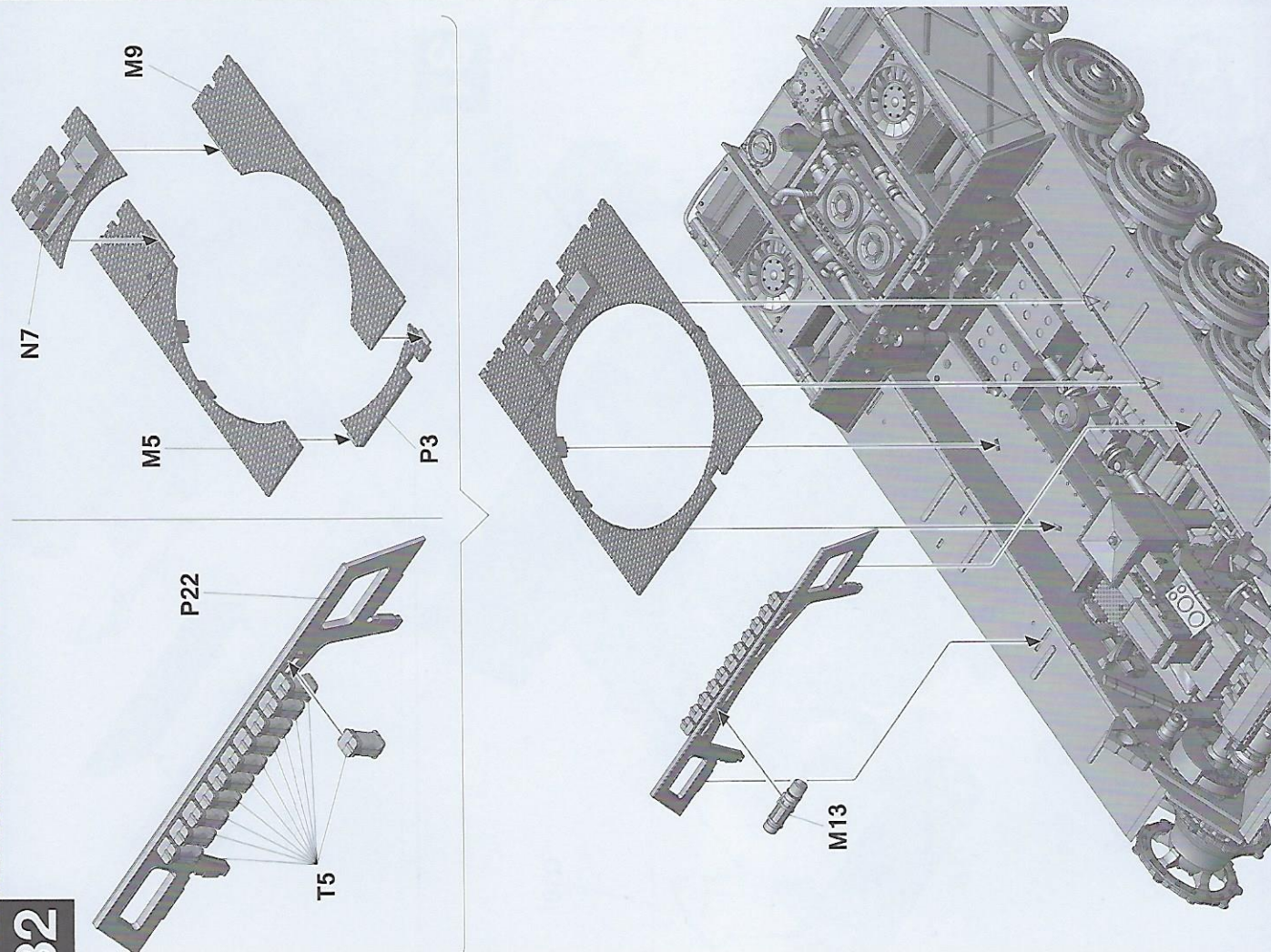

33

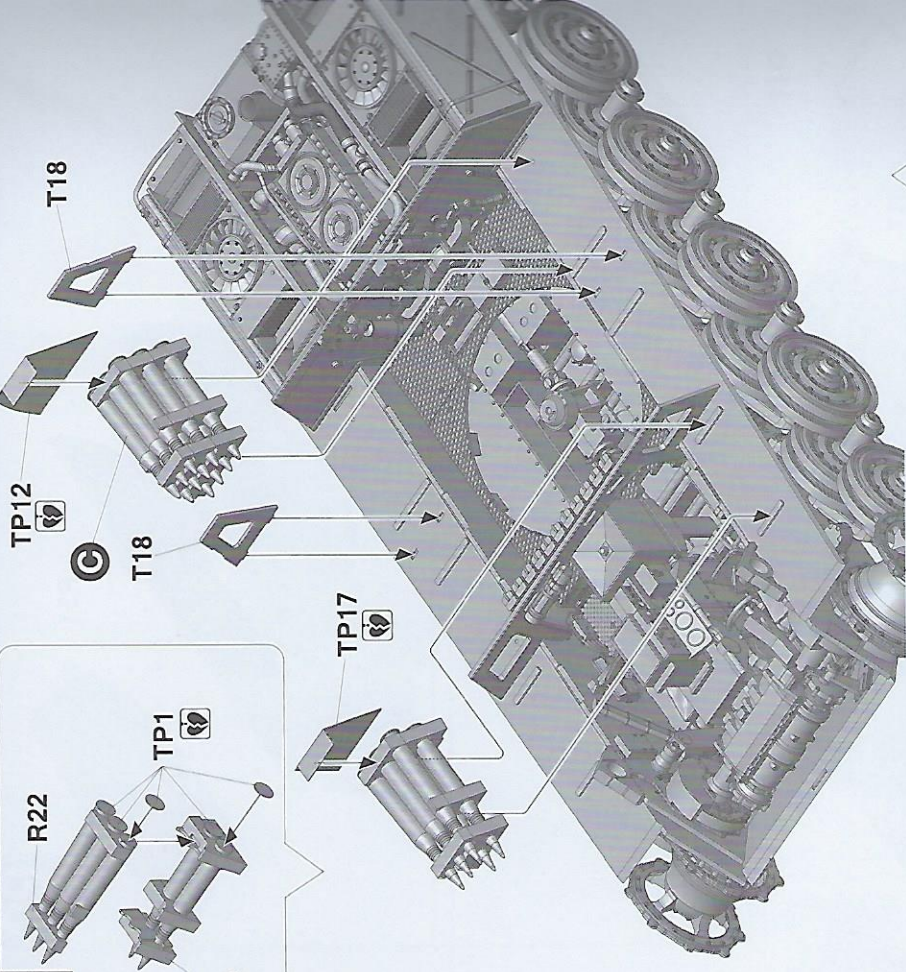

34

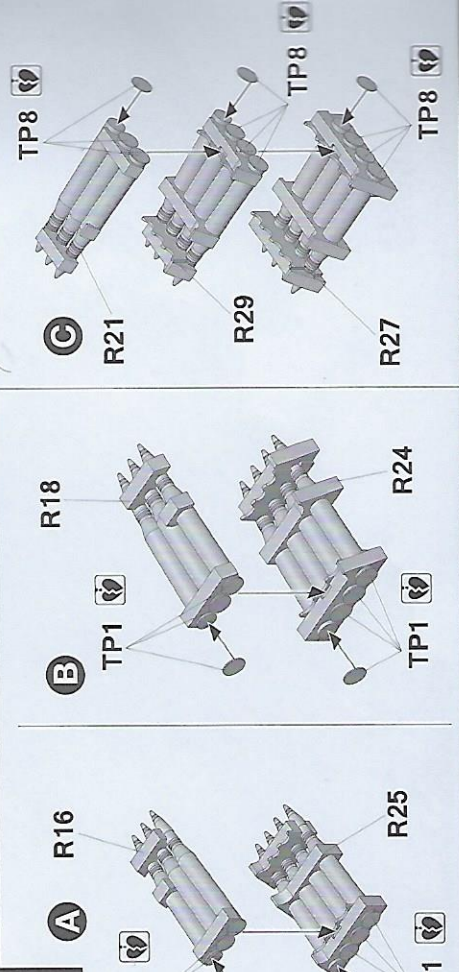

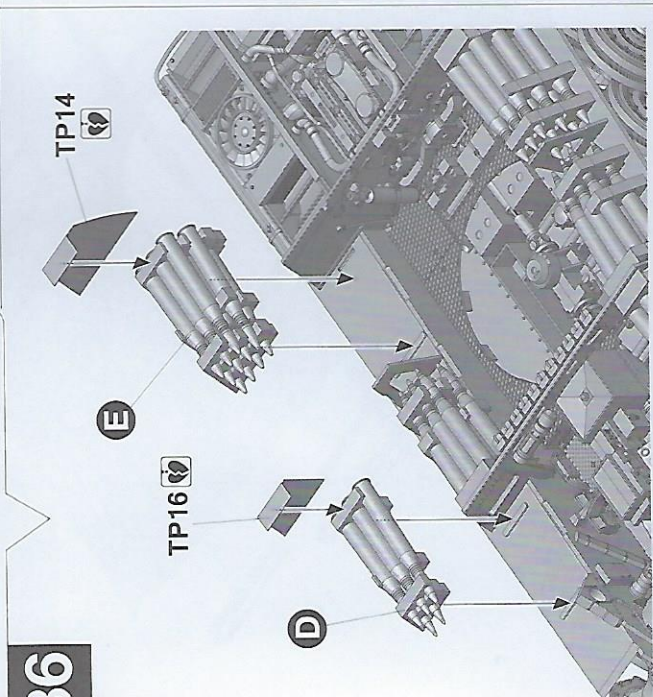
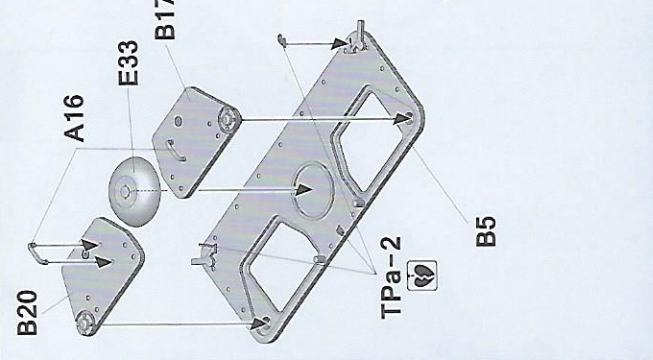
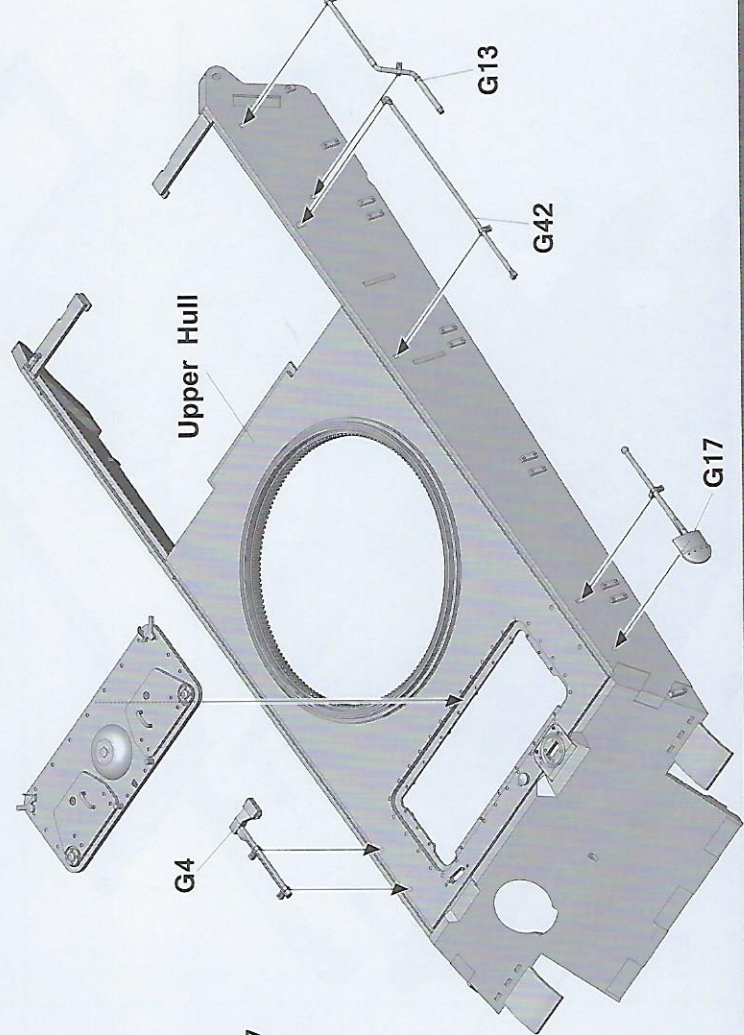
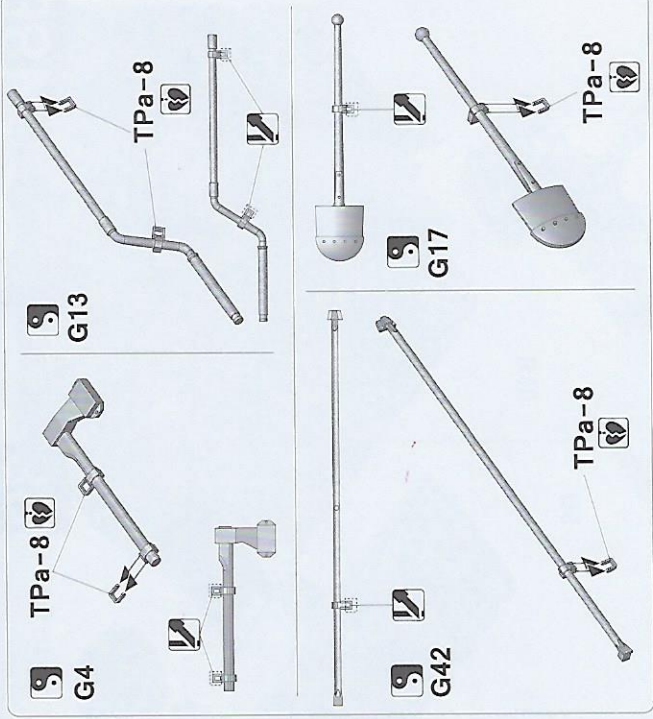
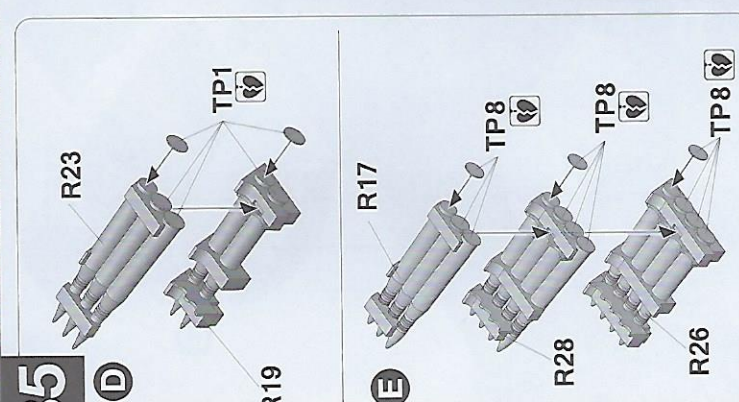
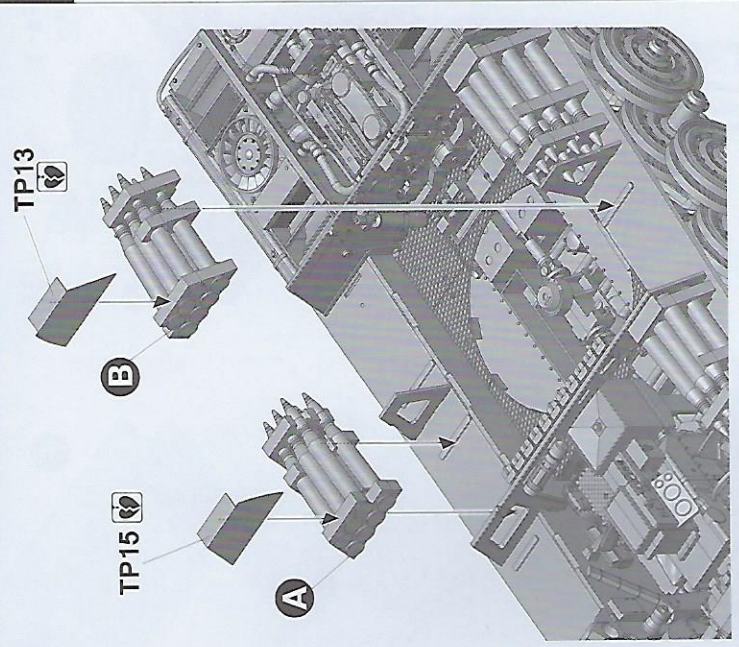

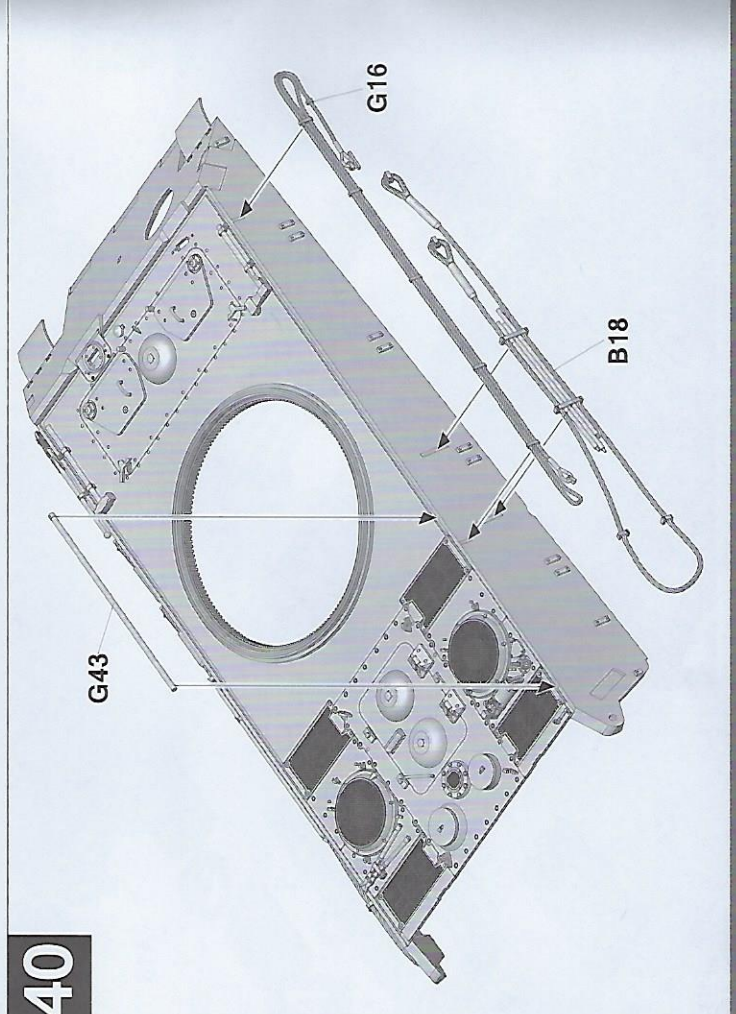
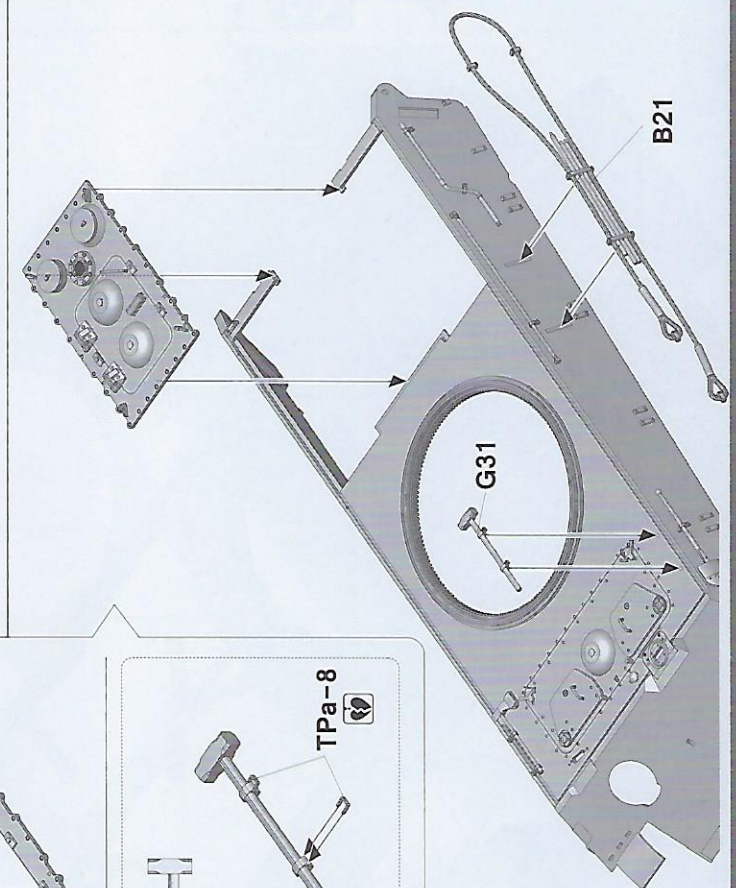
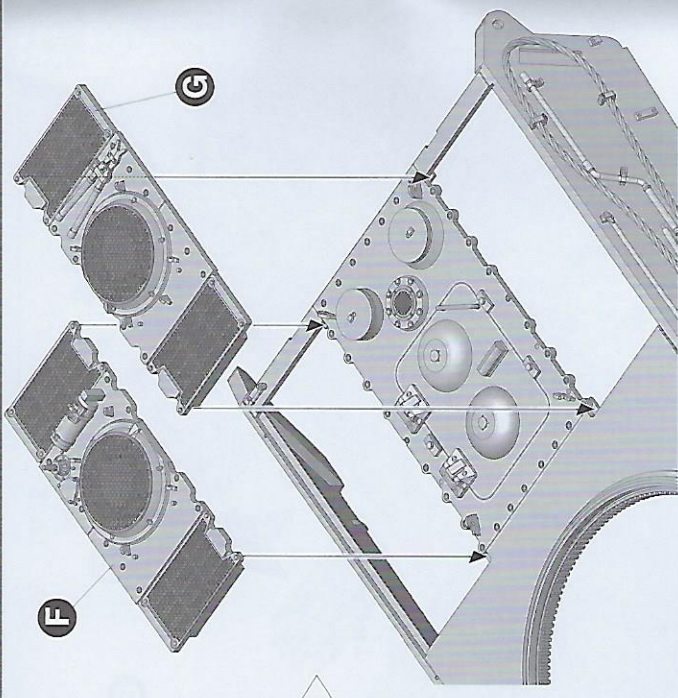
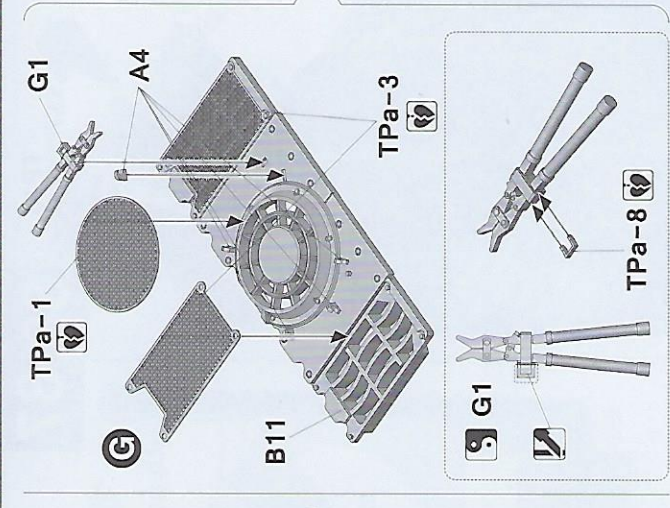
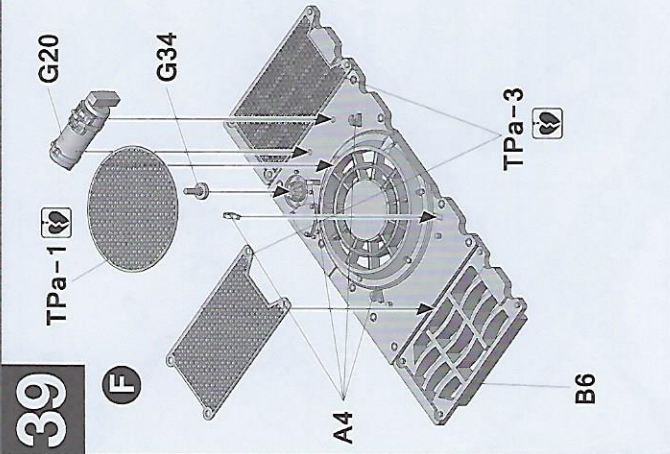
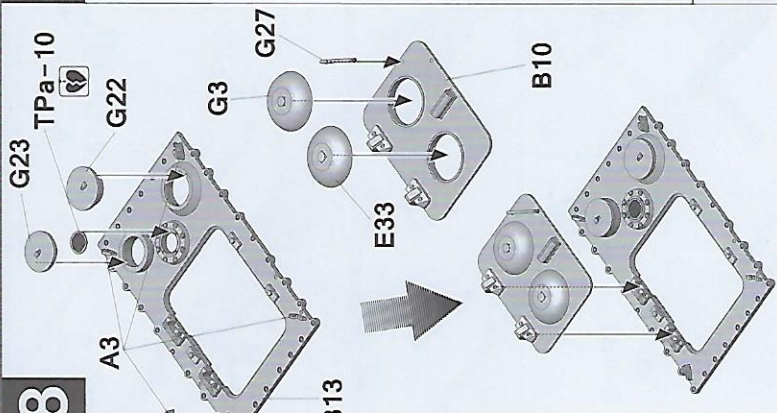

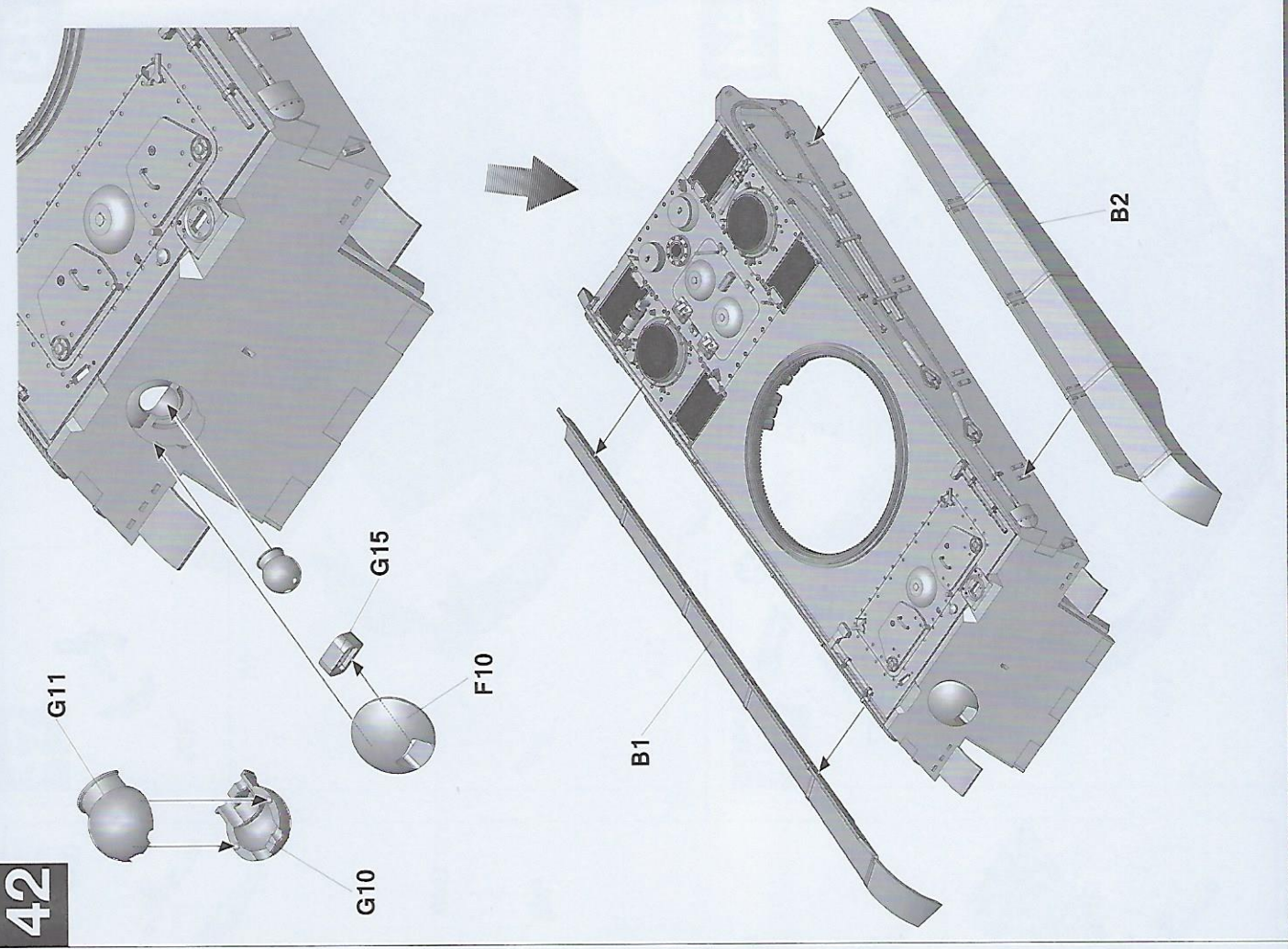
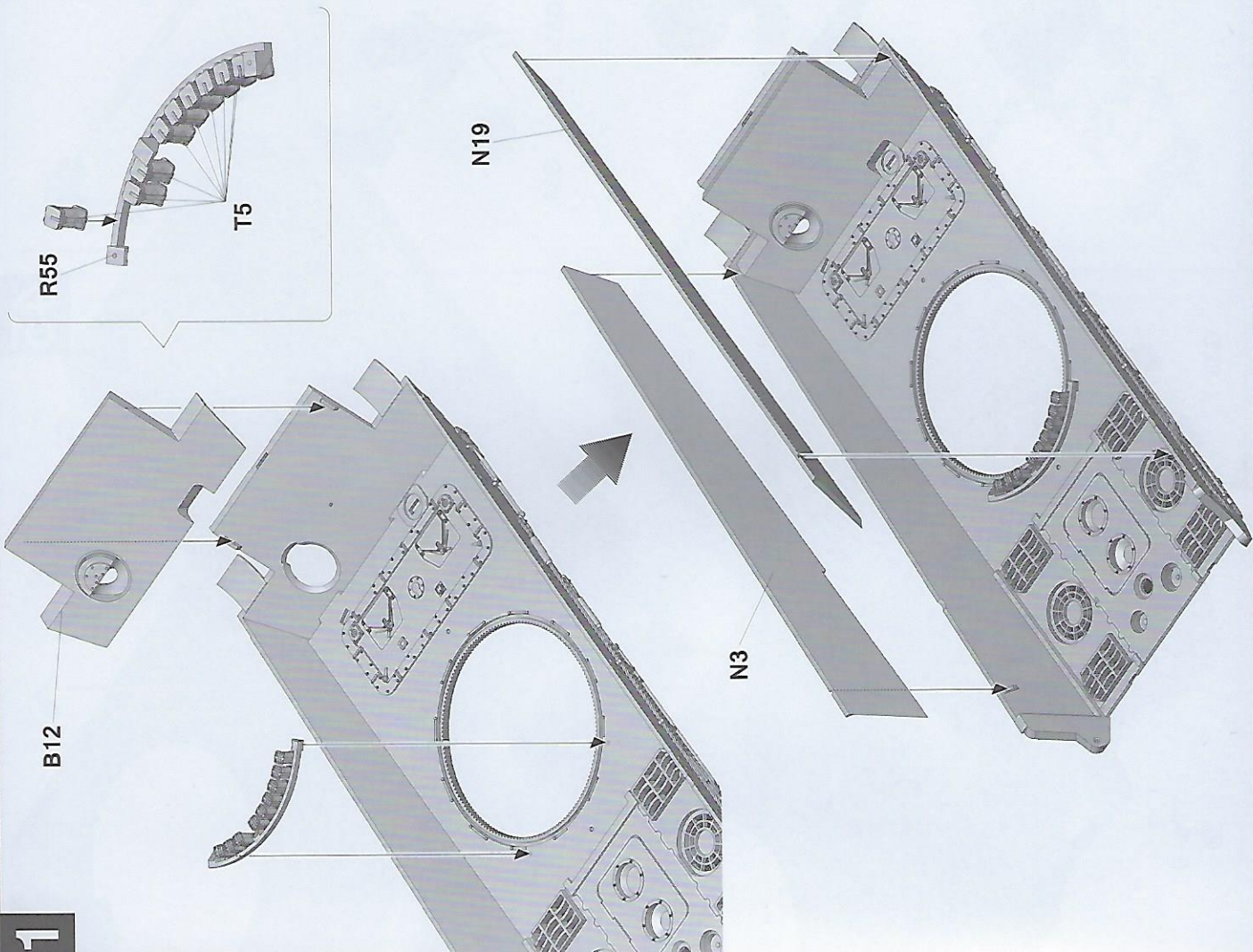

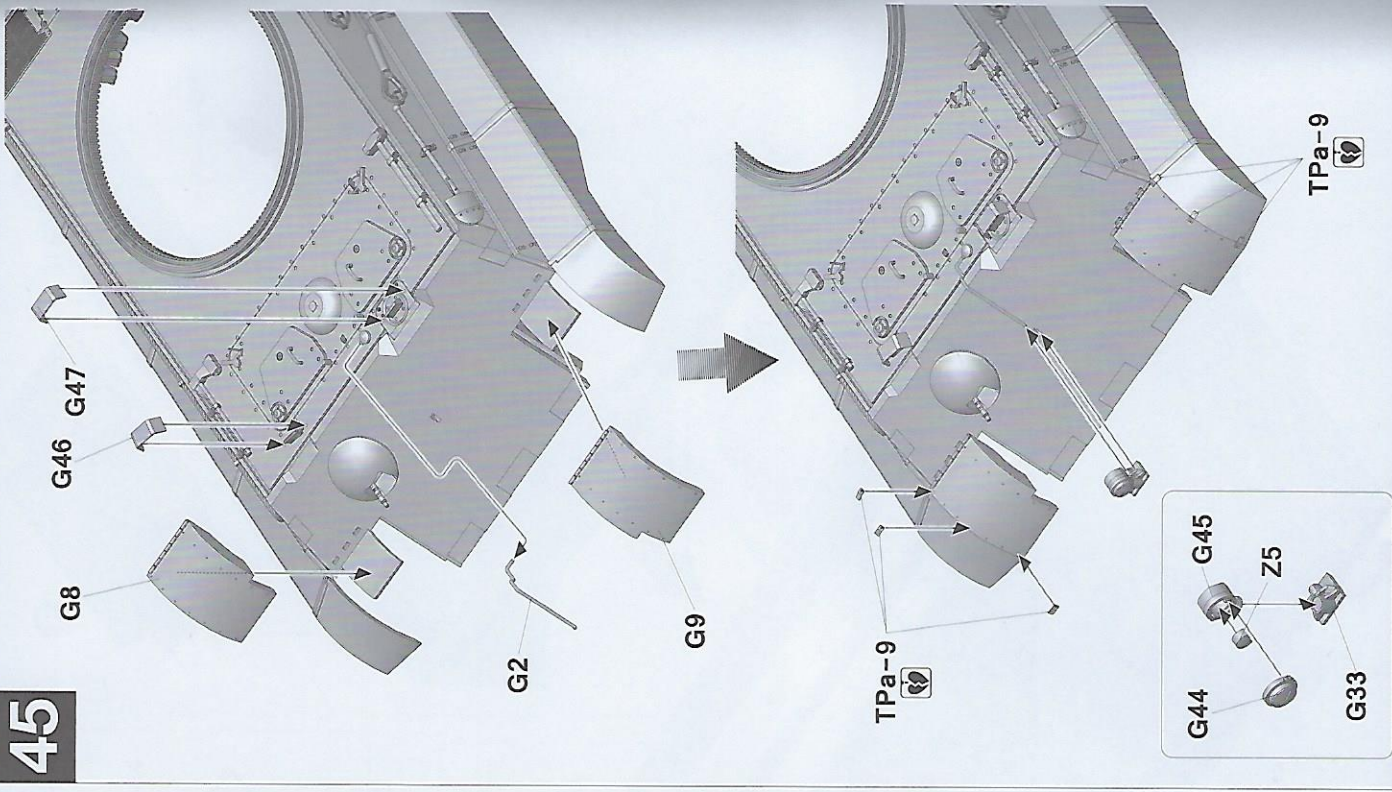
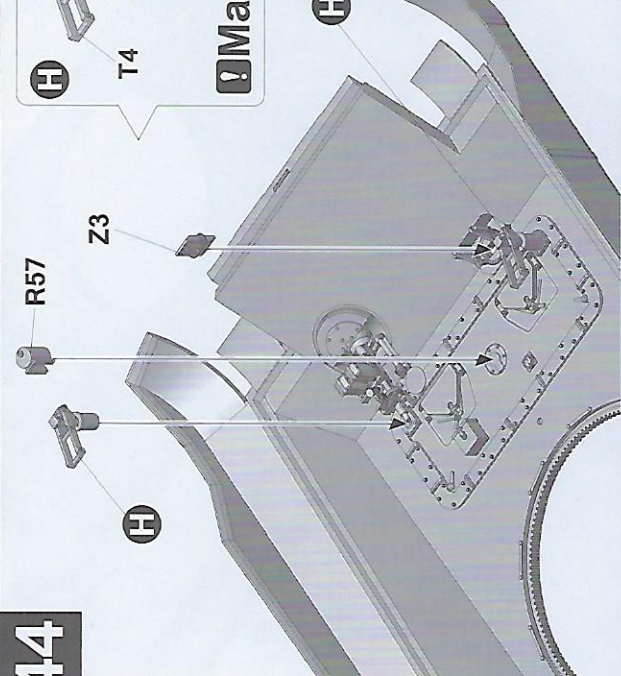
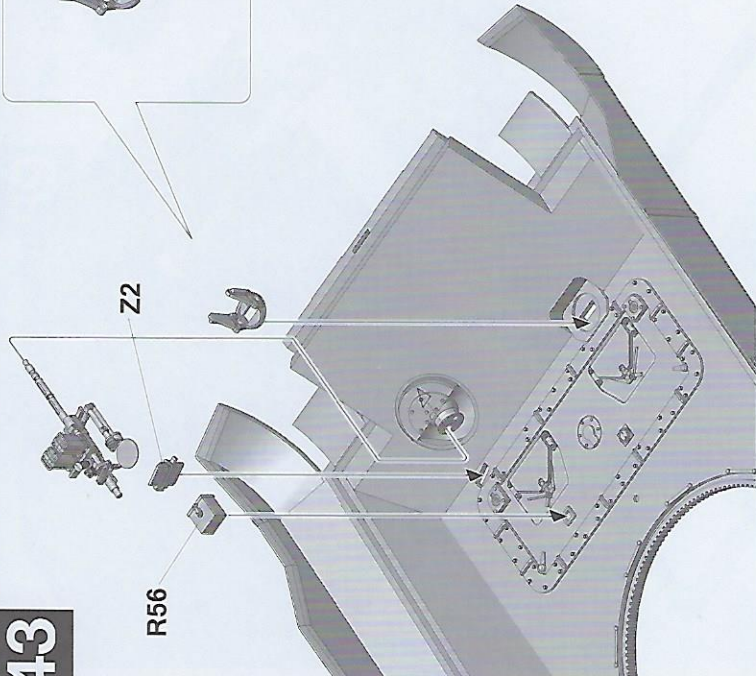

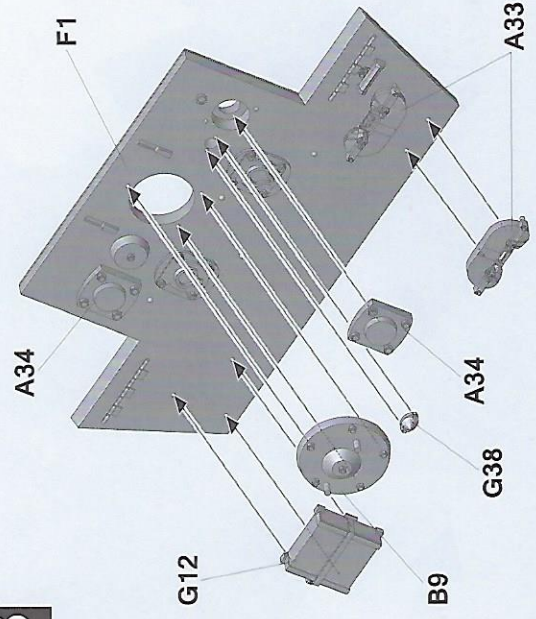
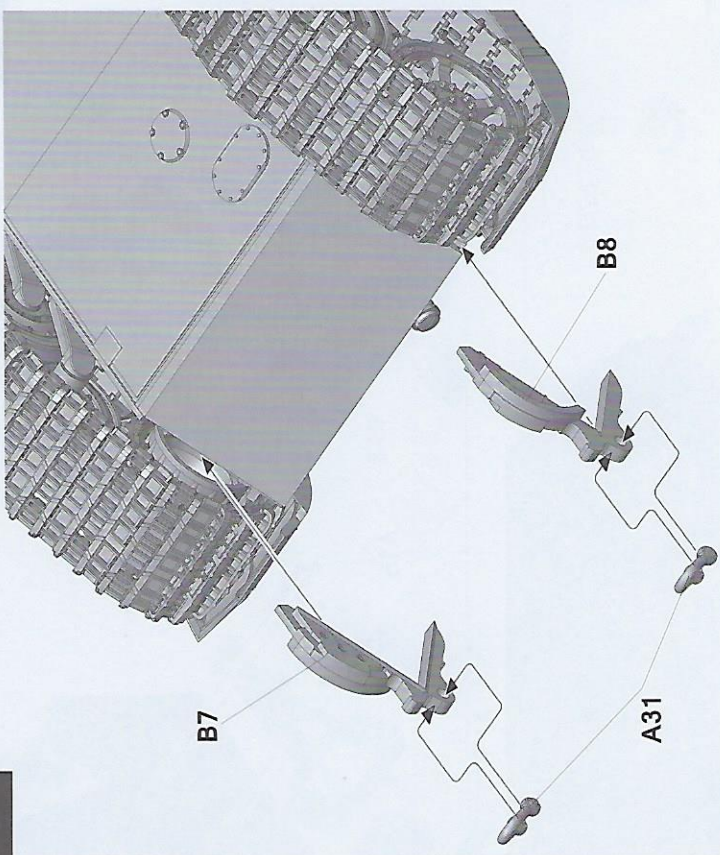
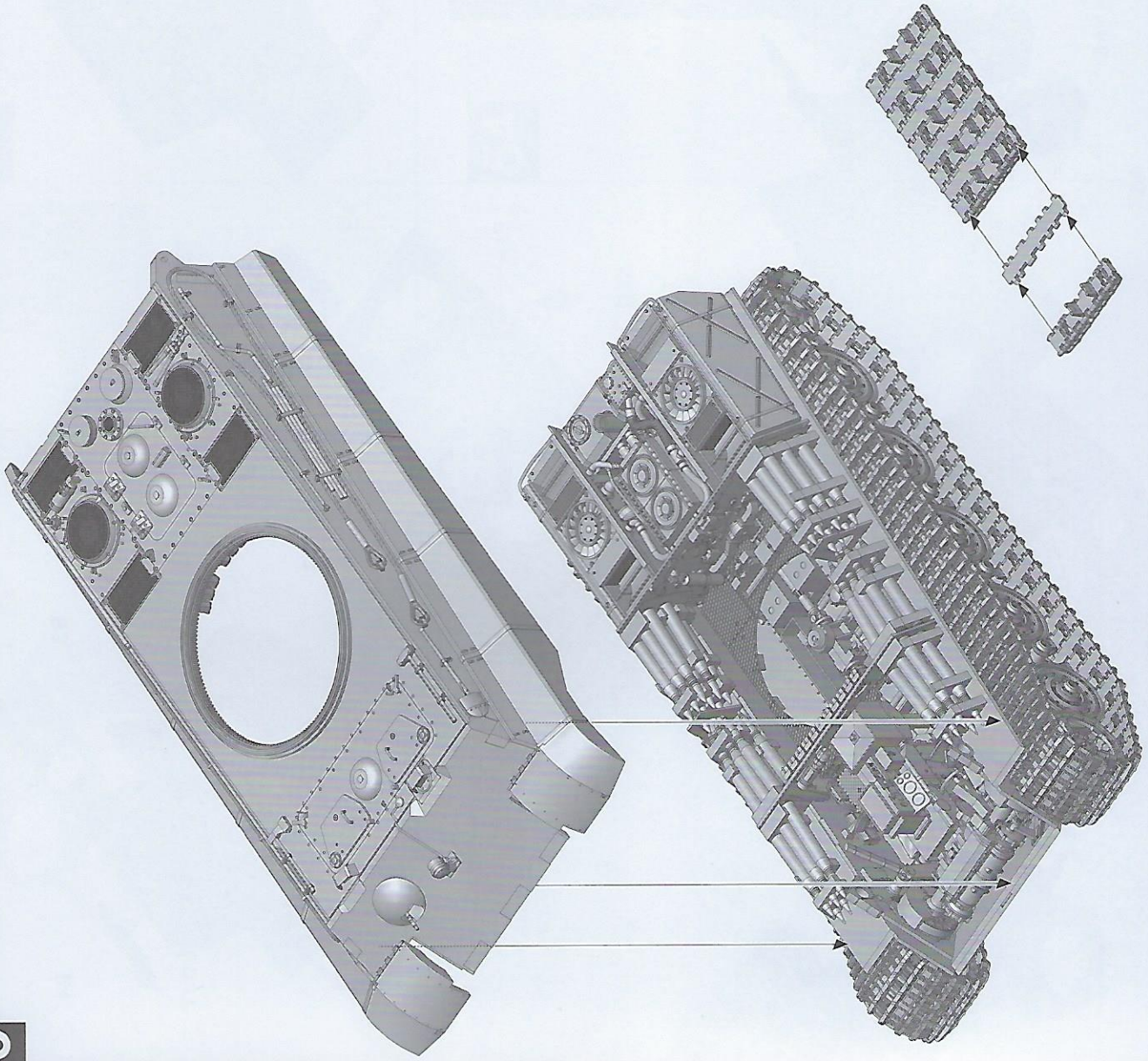

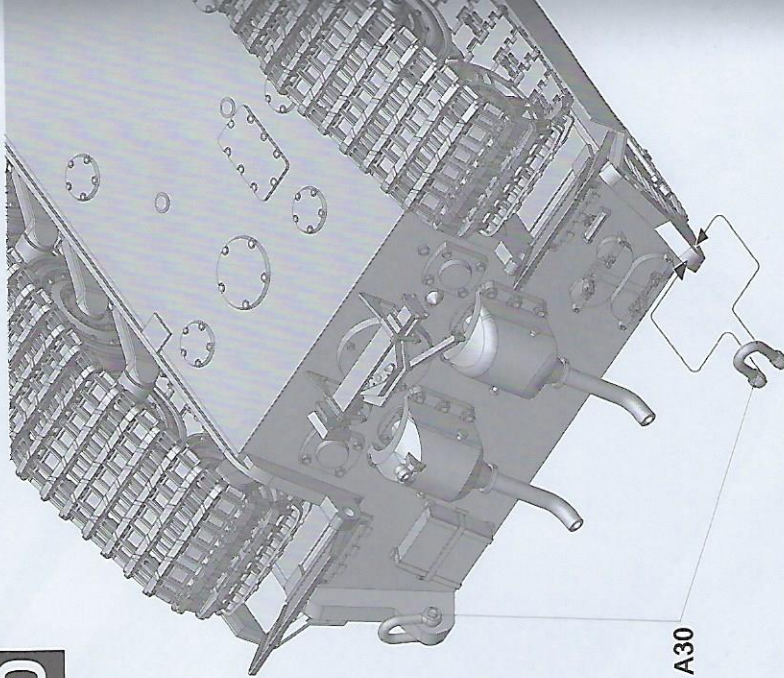
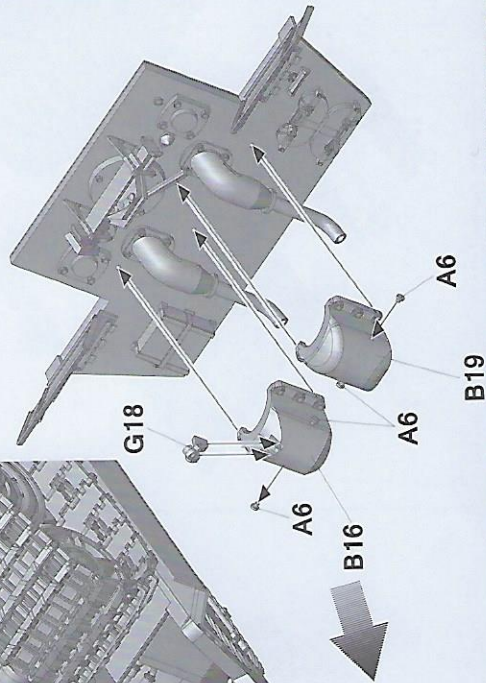
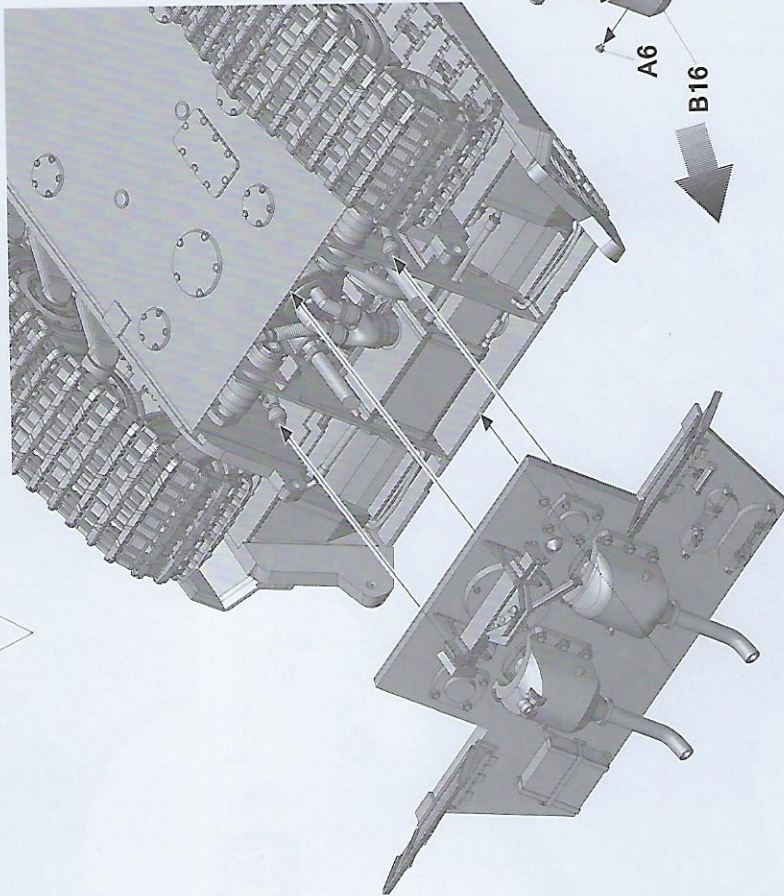
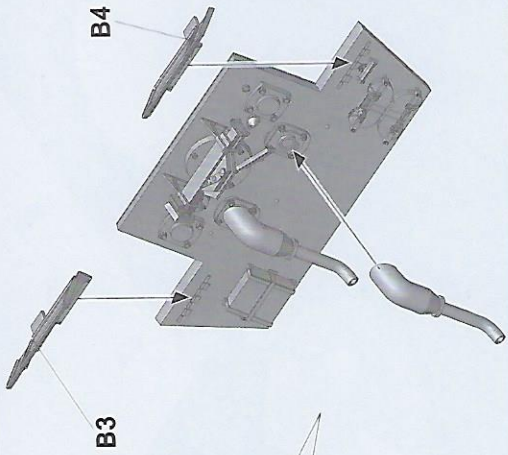
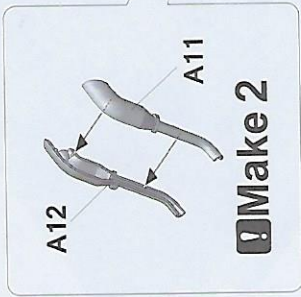
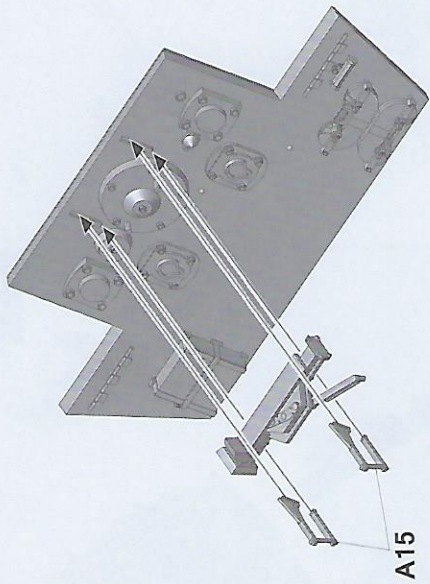
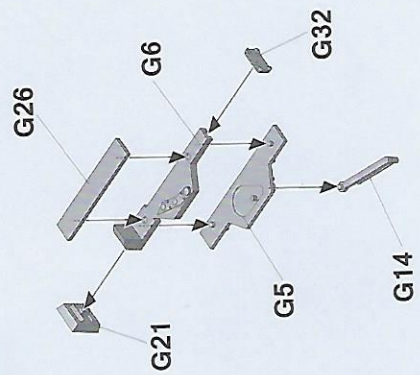

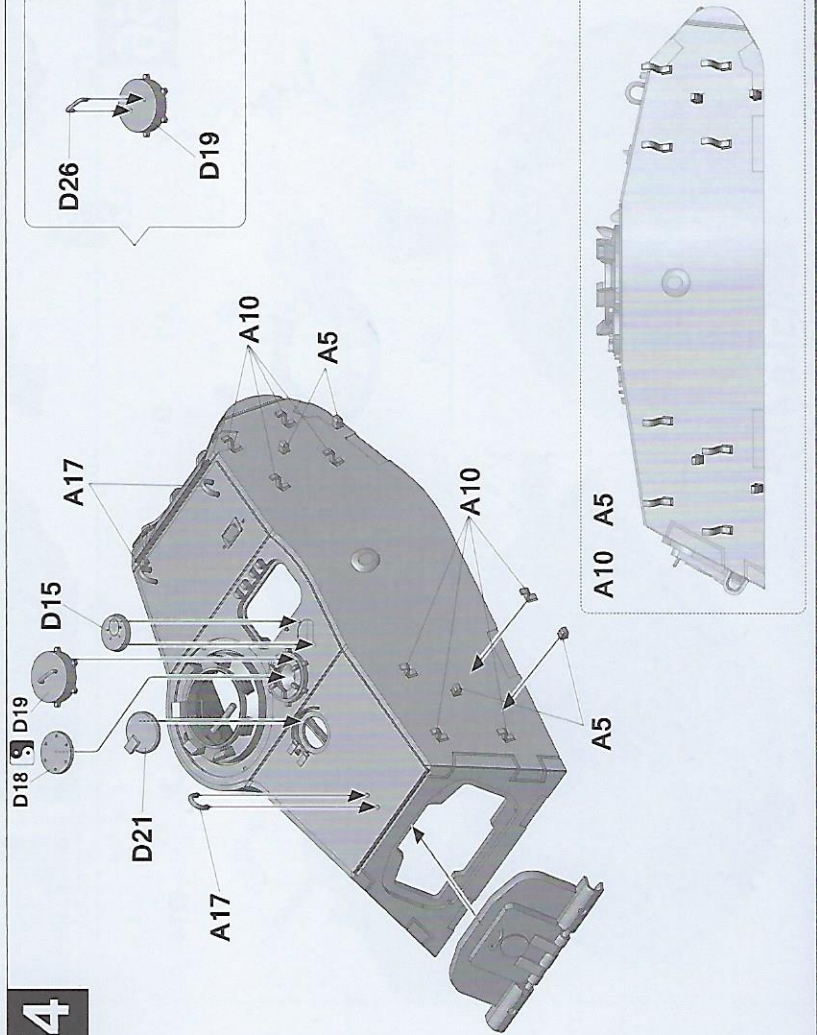
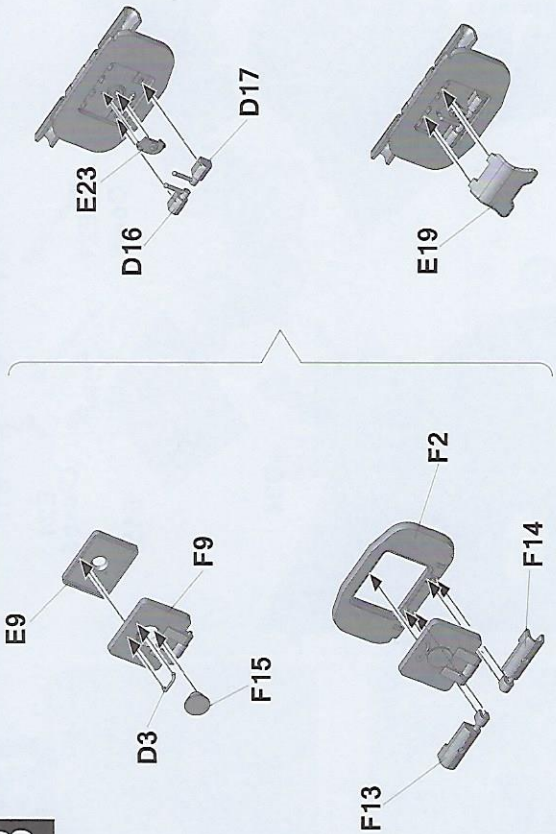
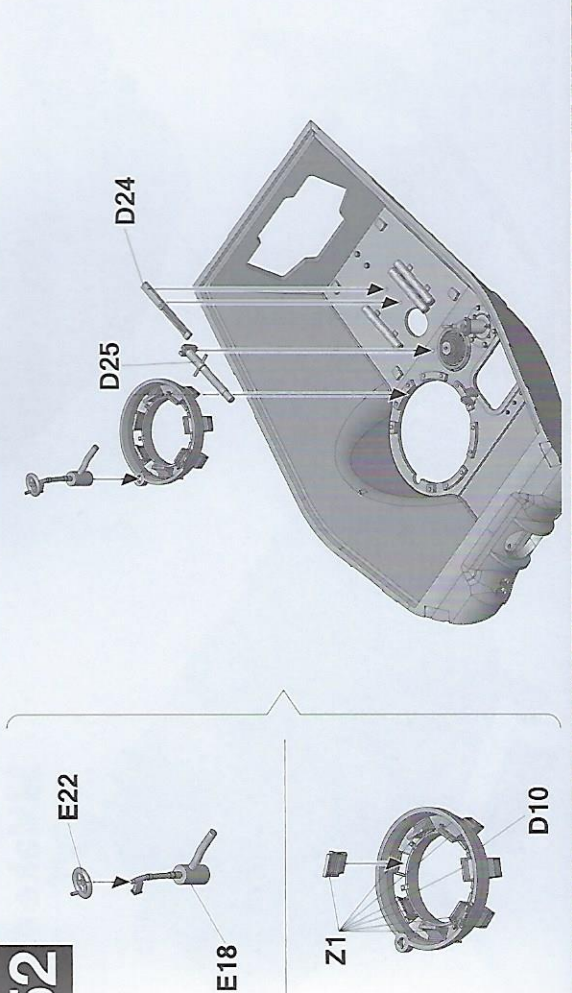
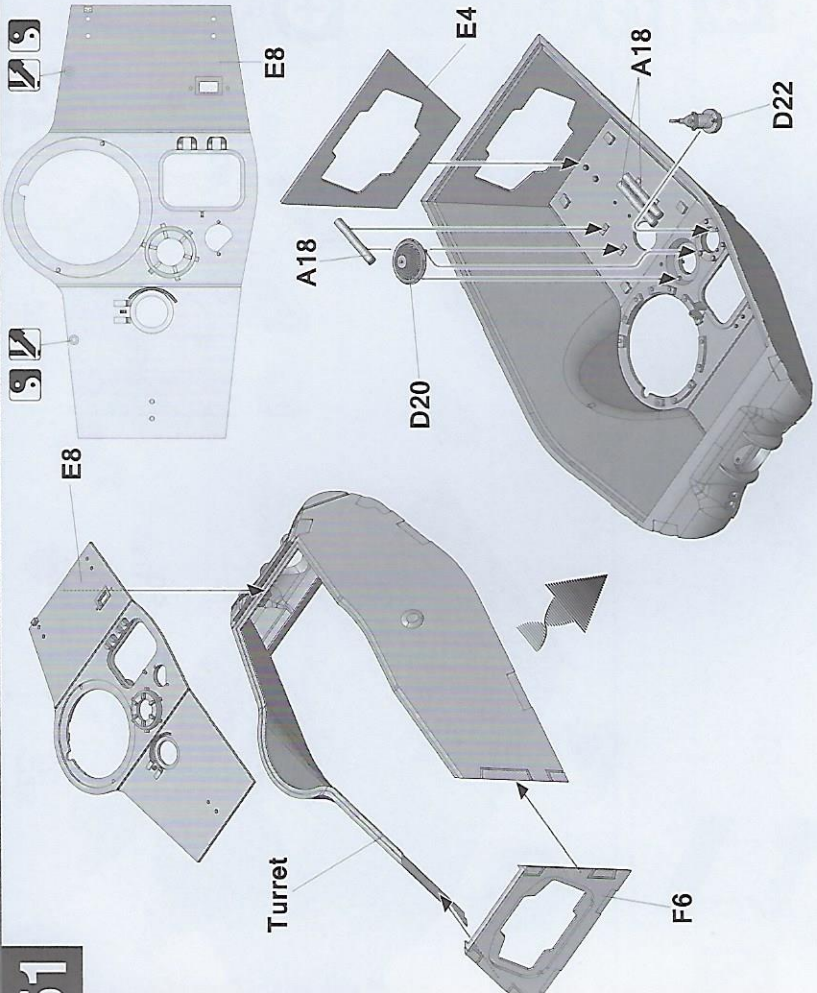

55

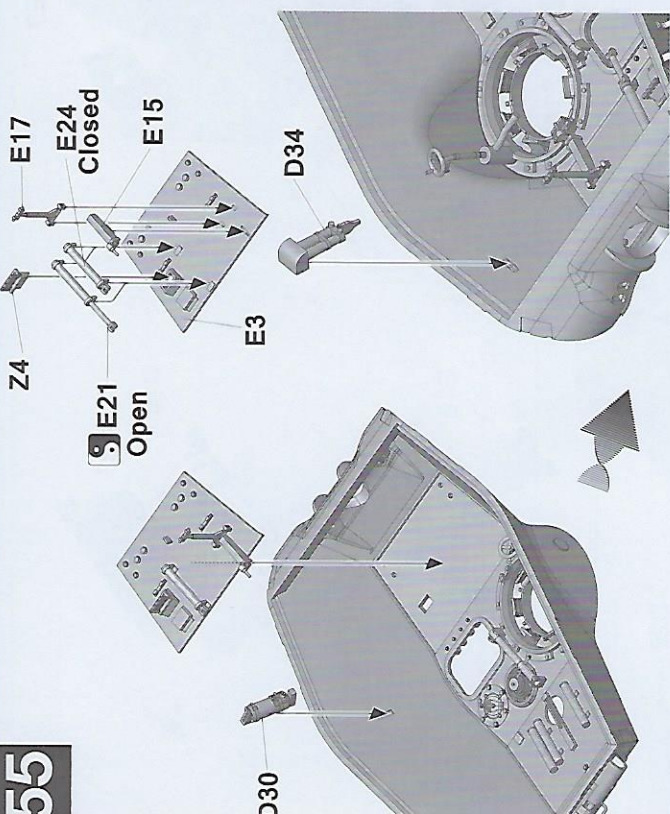

57

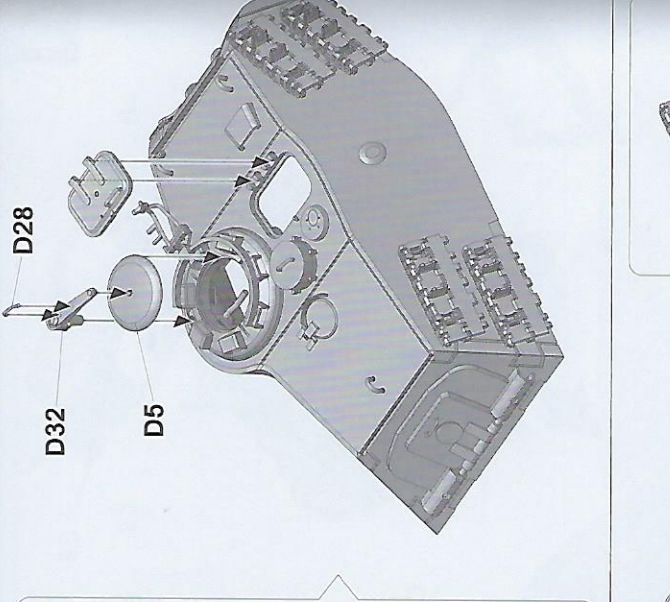
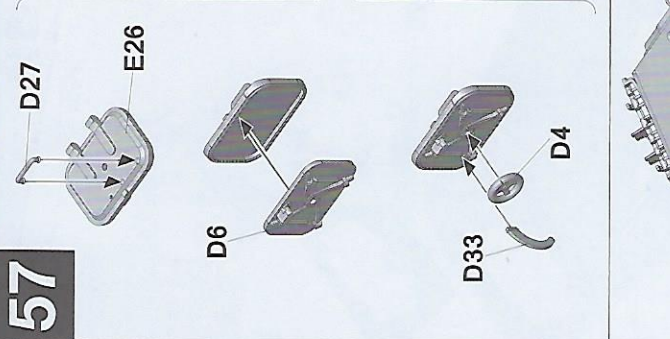

56

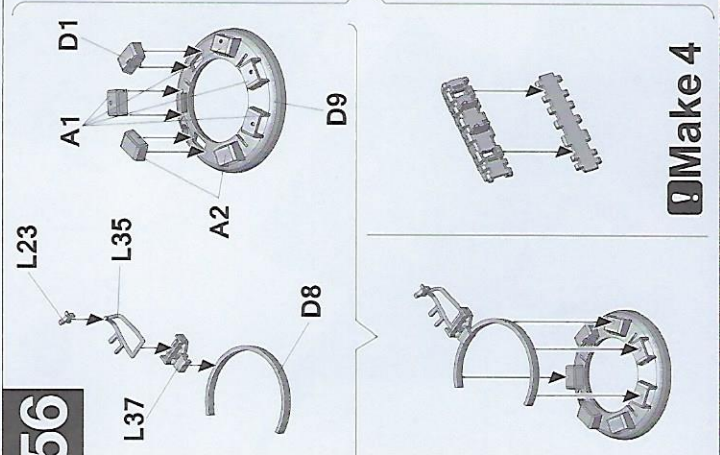

58

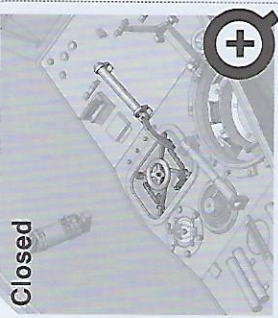
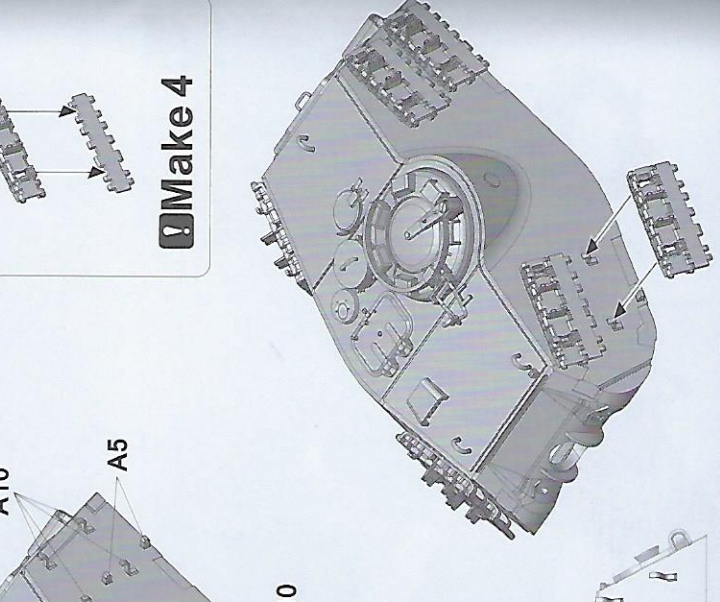
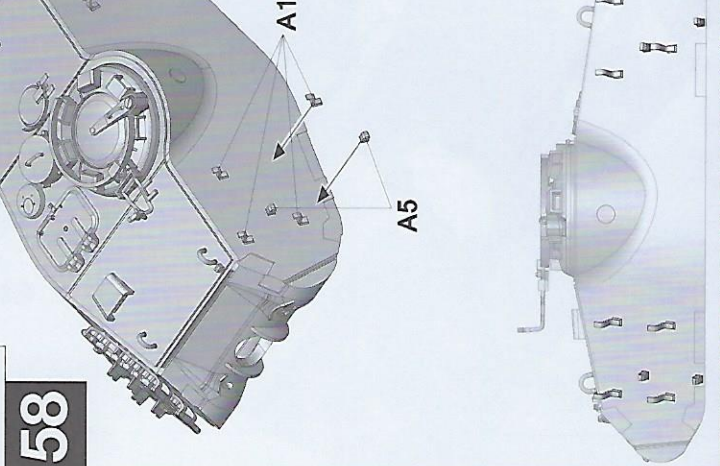

Make 4

Make 4

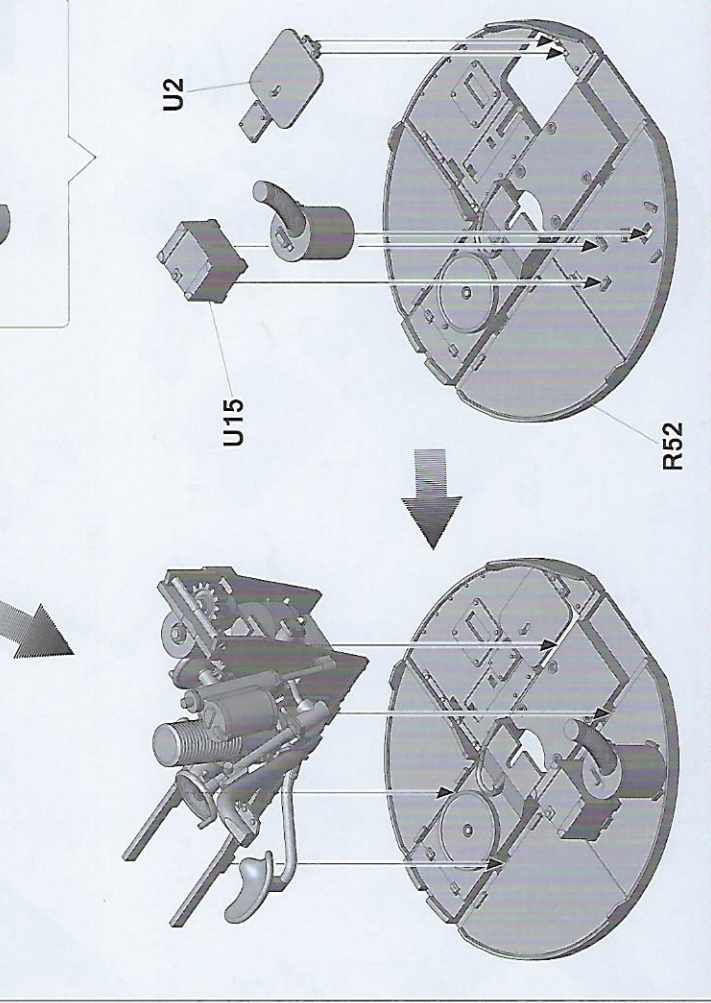
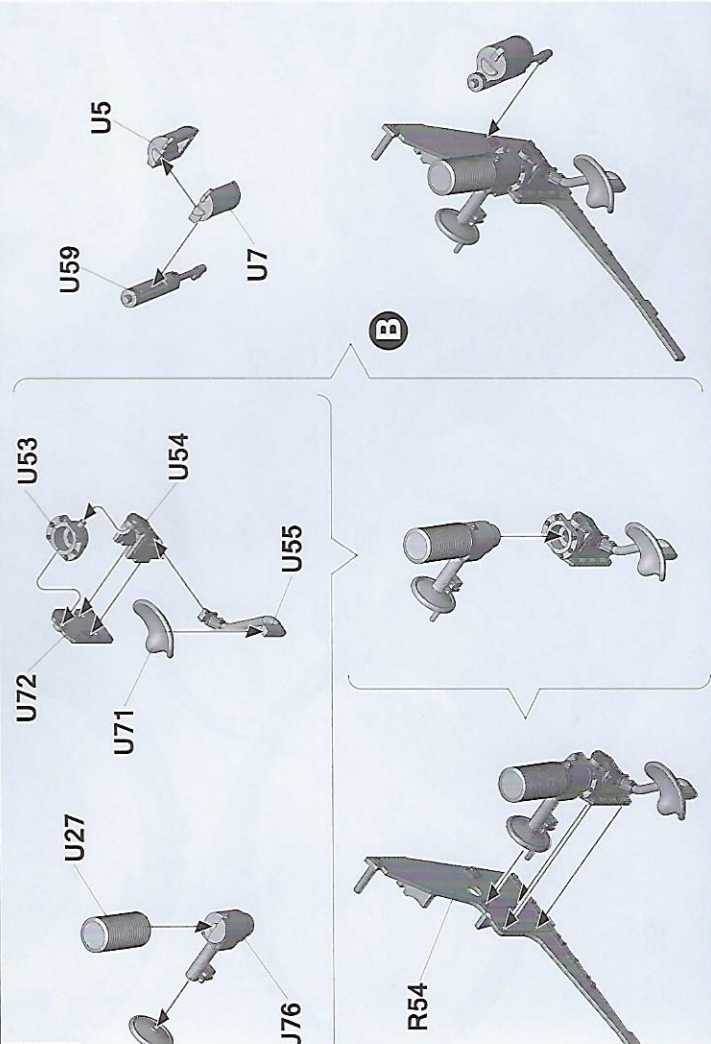
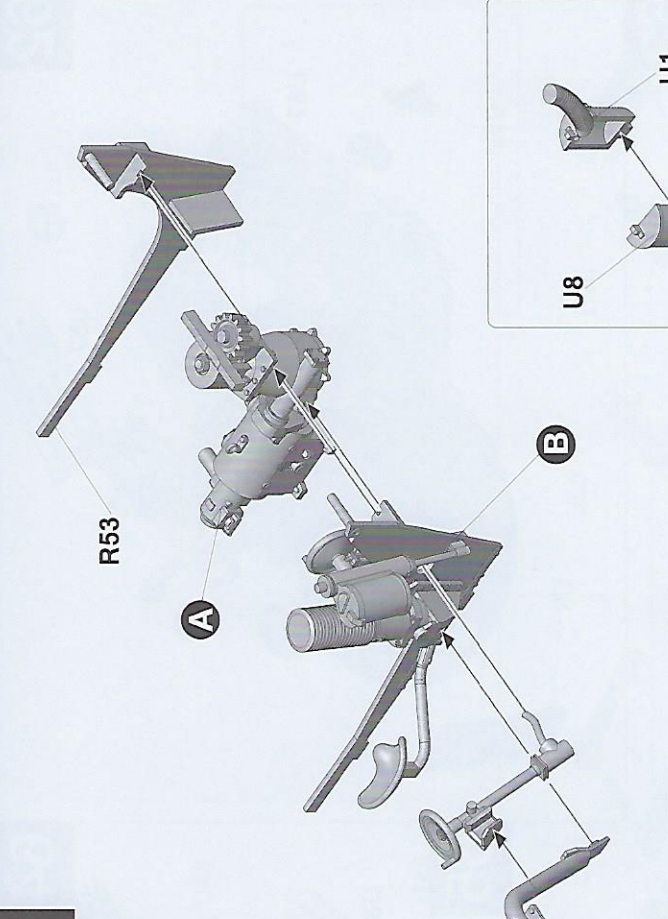
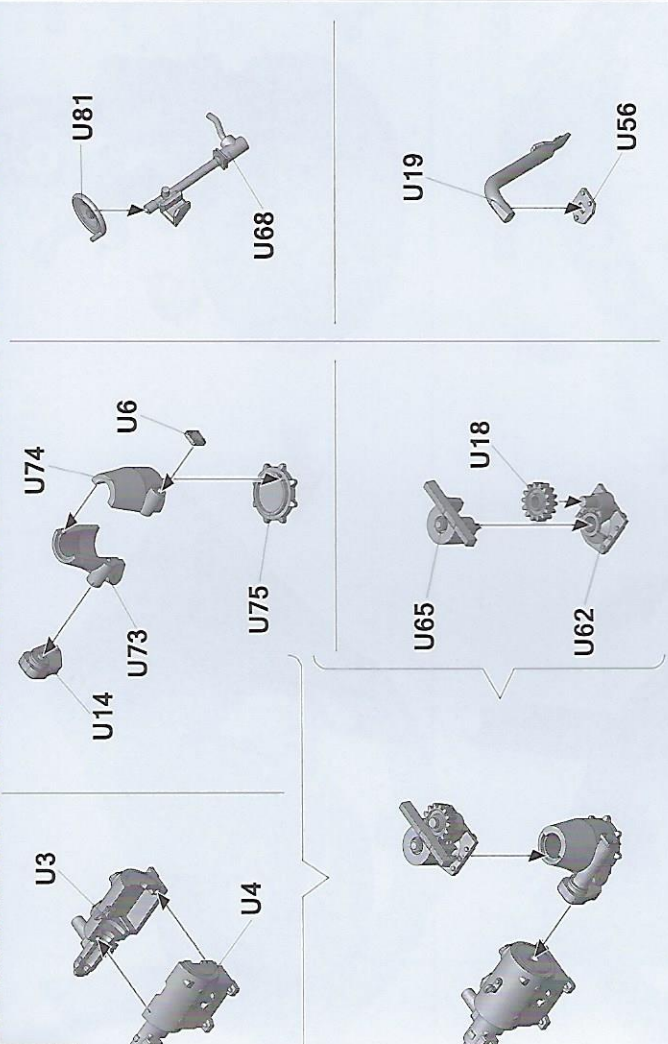

62

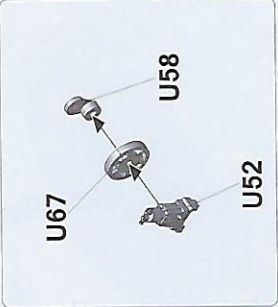
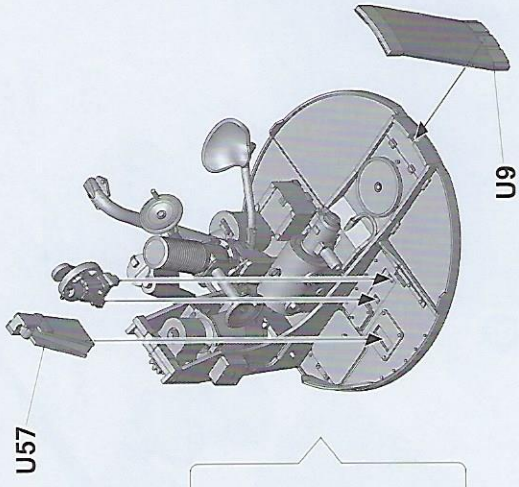

64

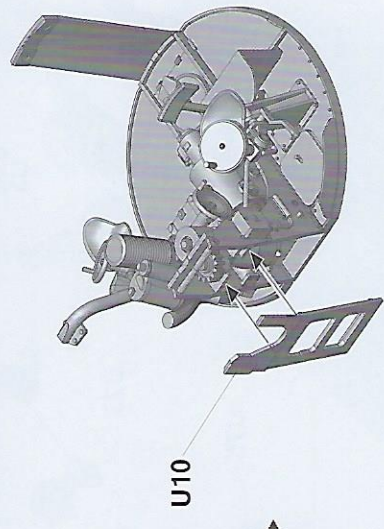
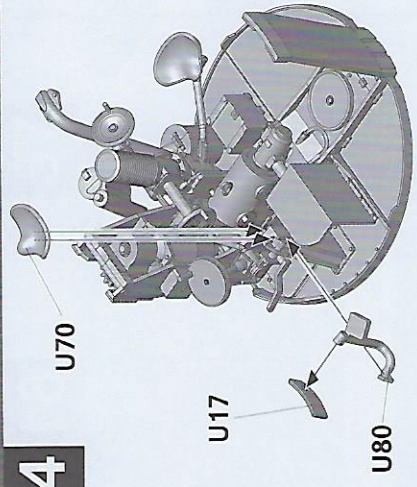

65

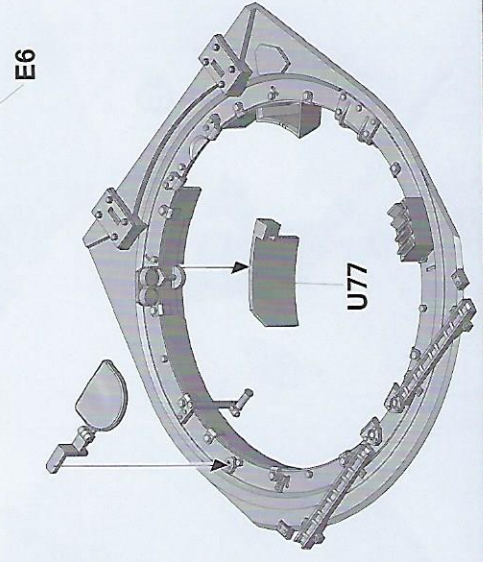
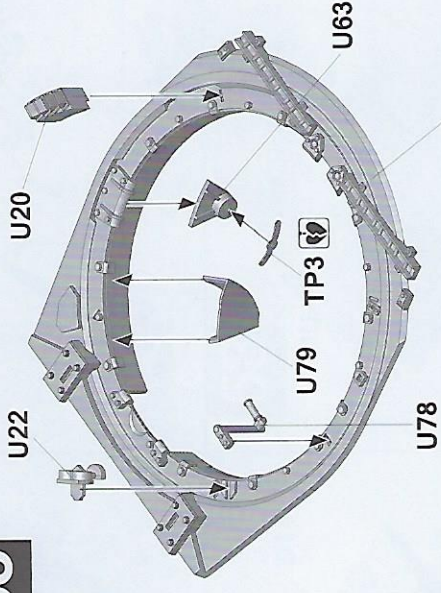

63

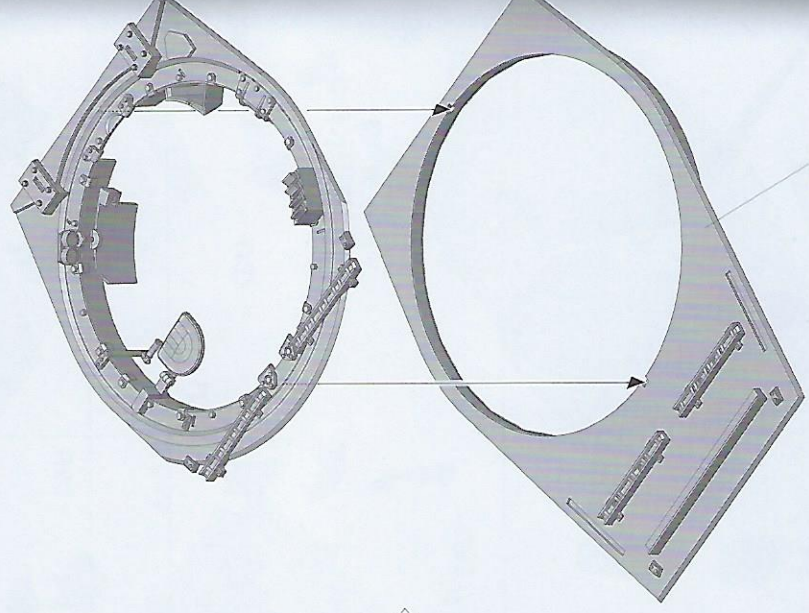
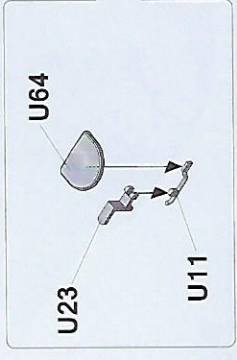
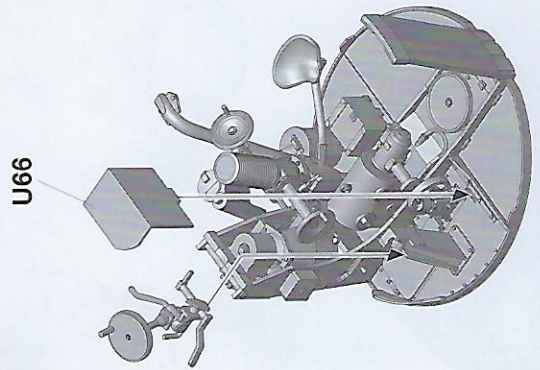
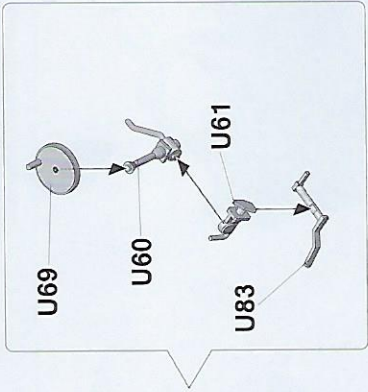

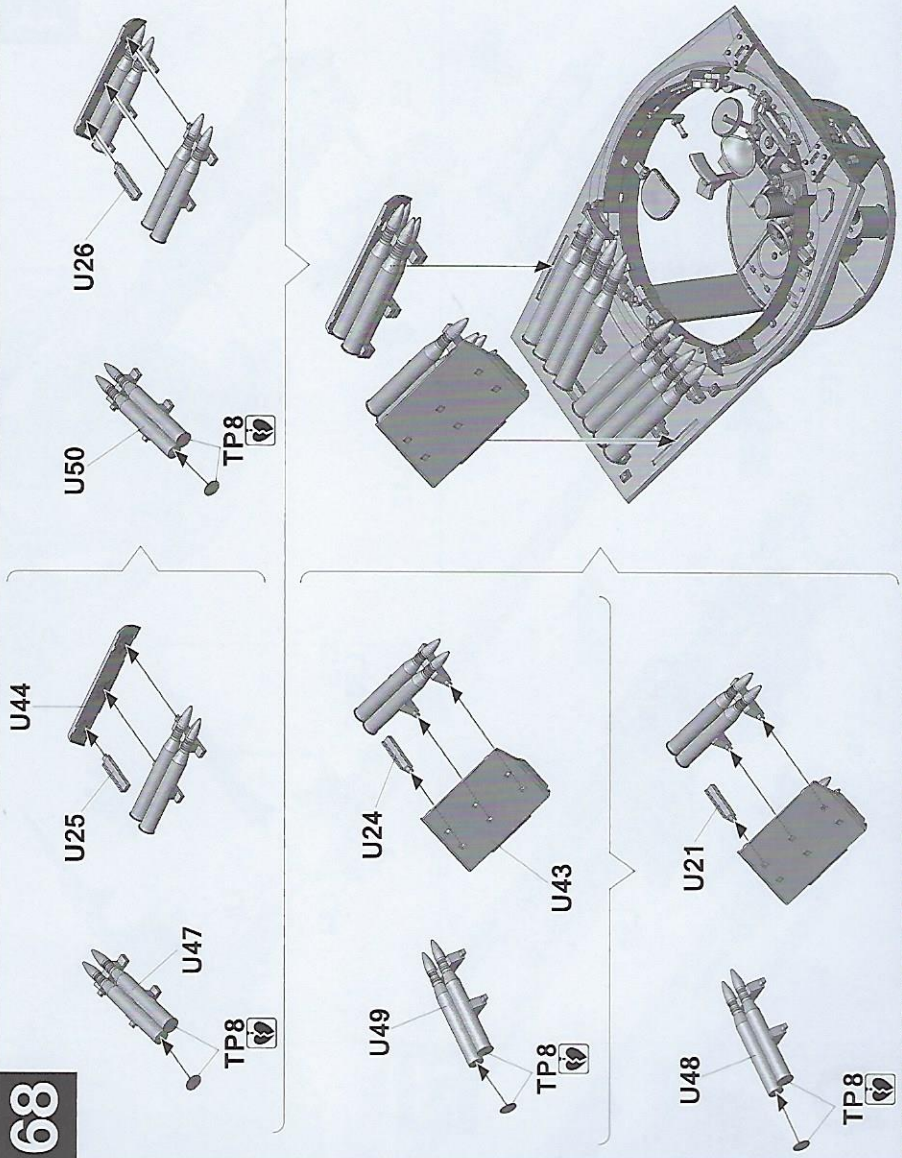
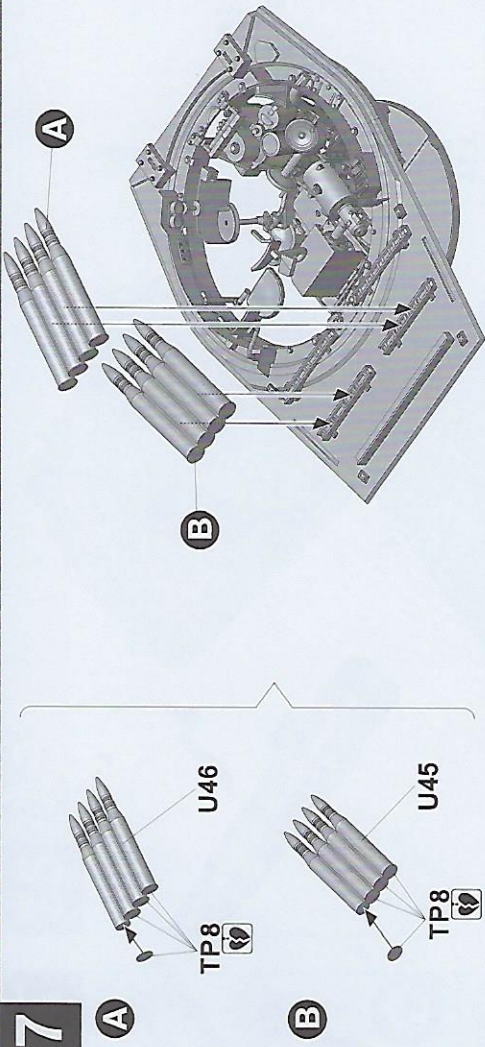
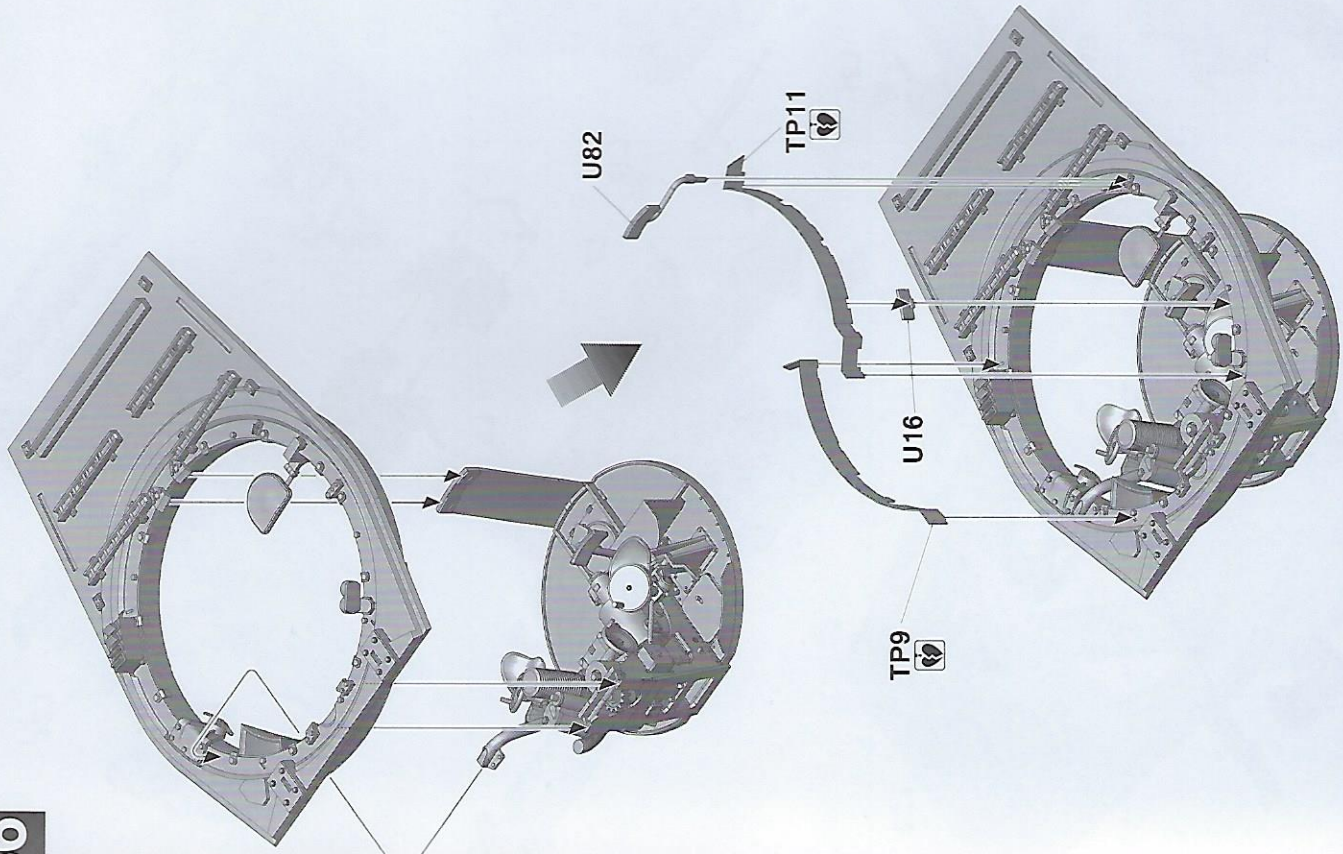

69

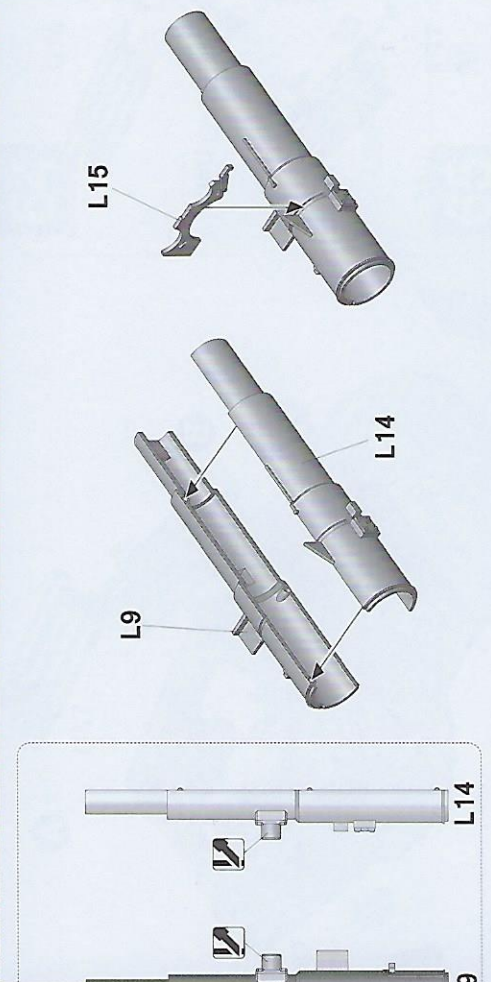

70

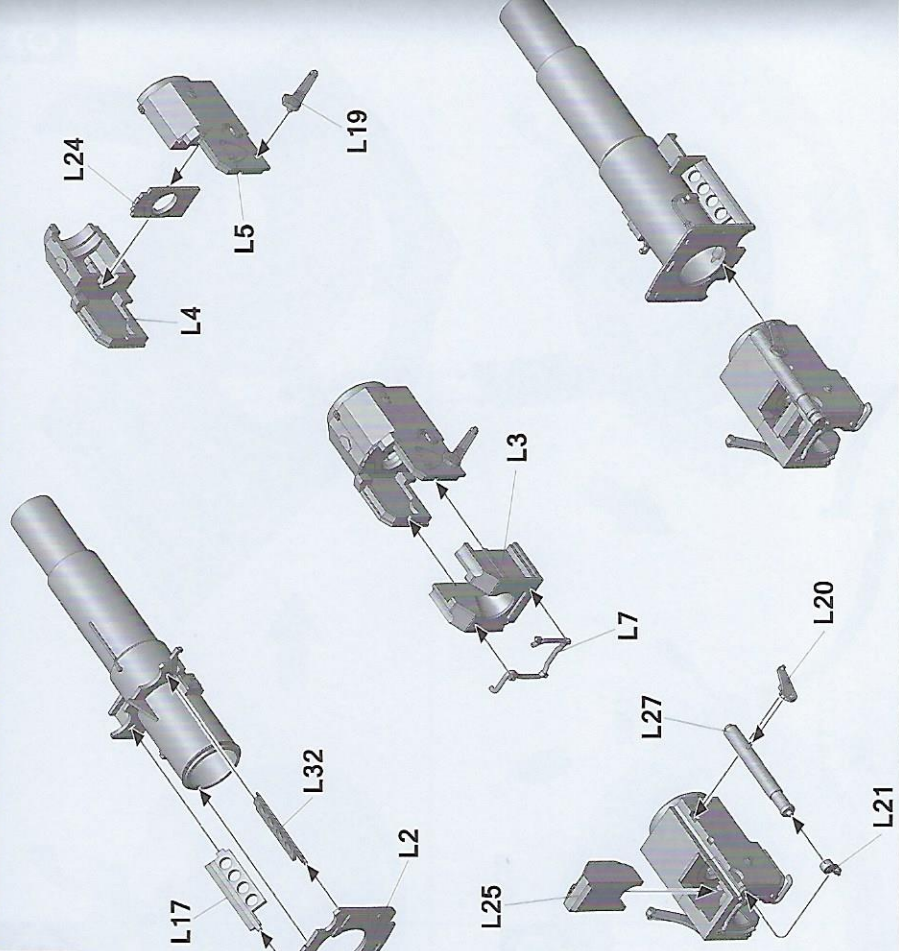

71

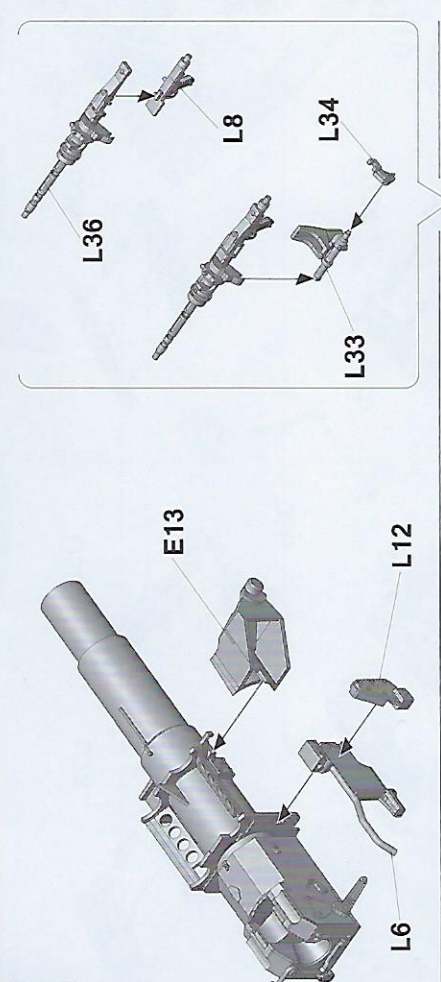

72

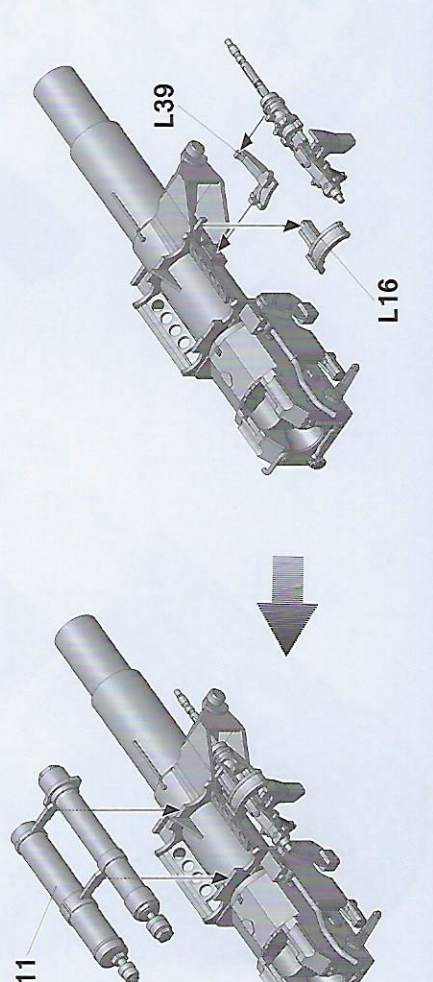
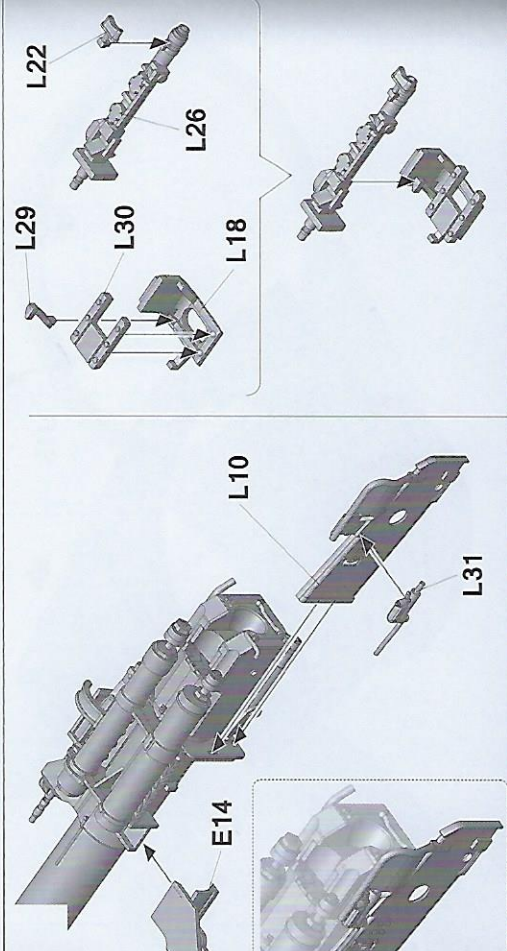

27

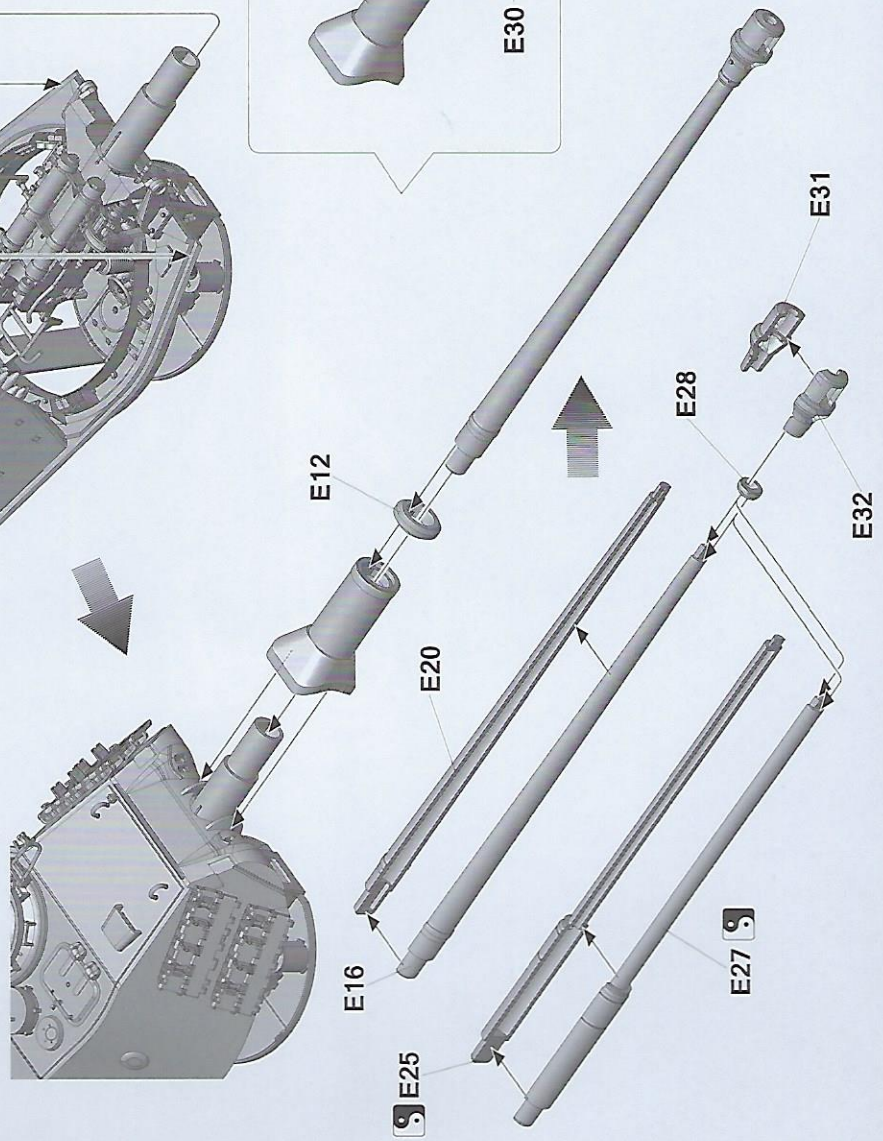
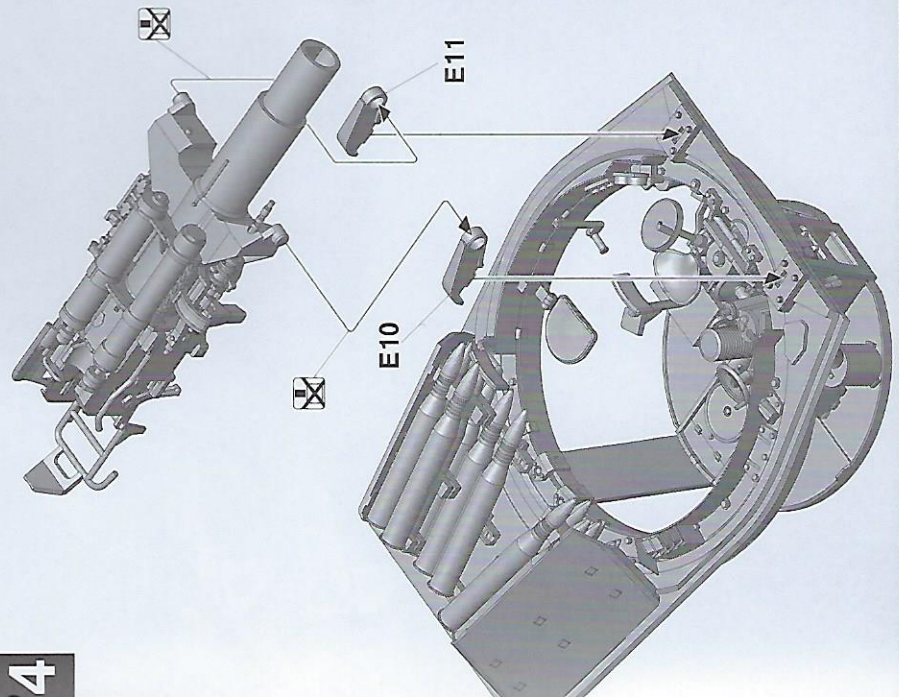
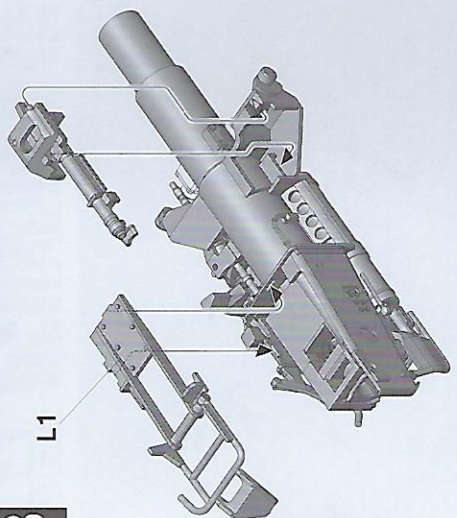

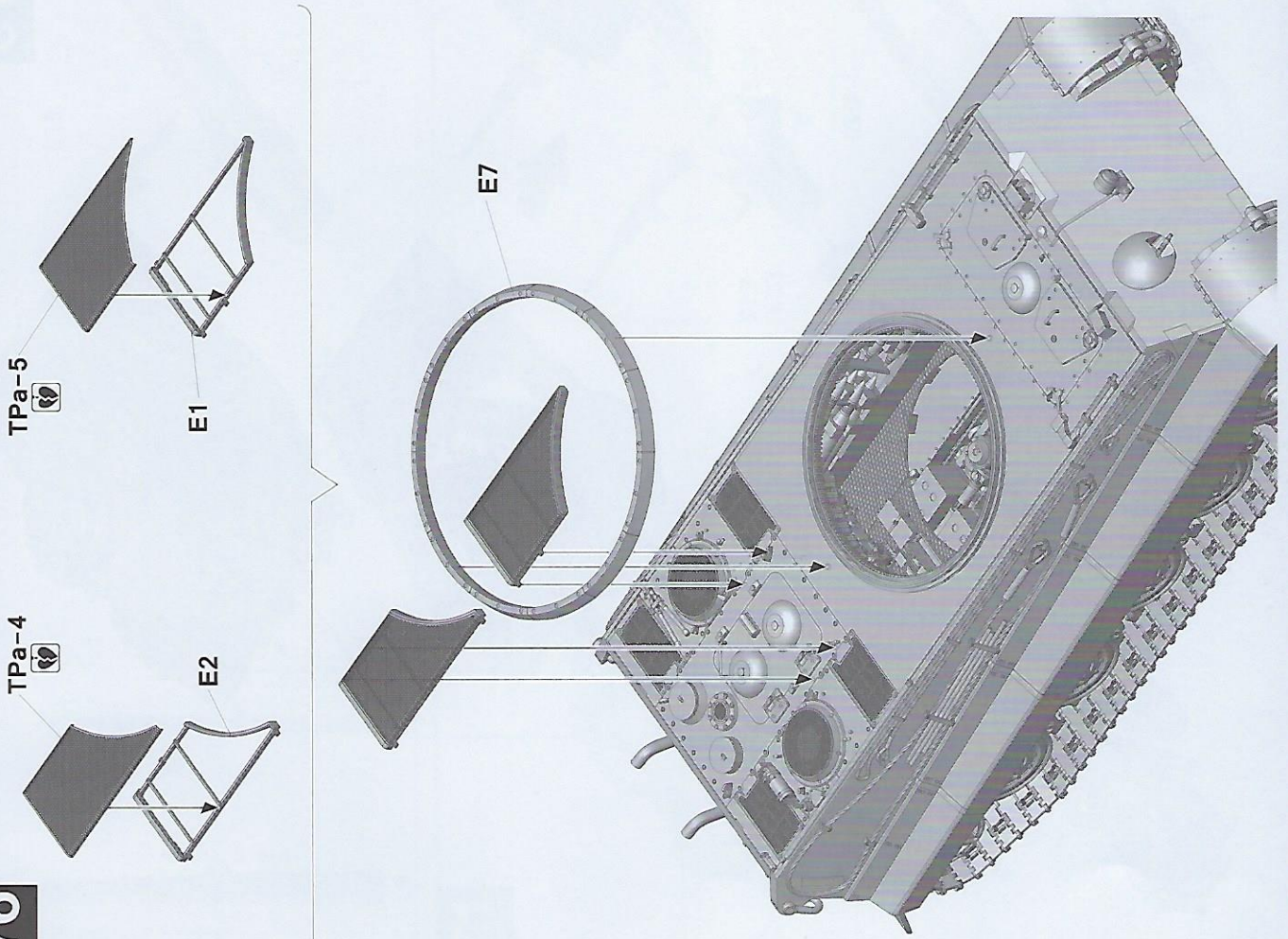
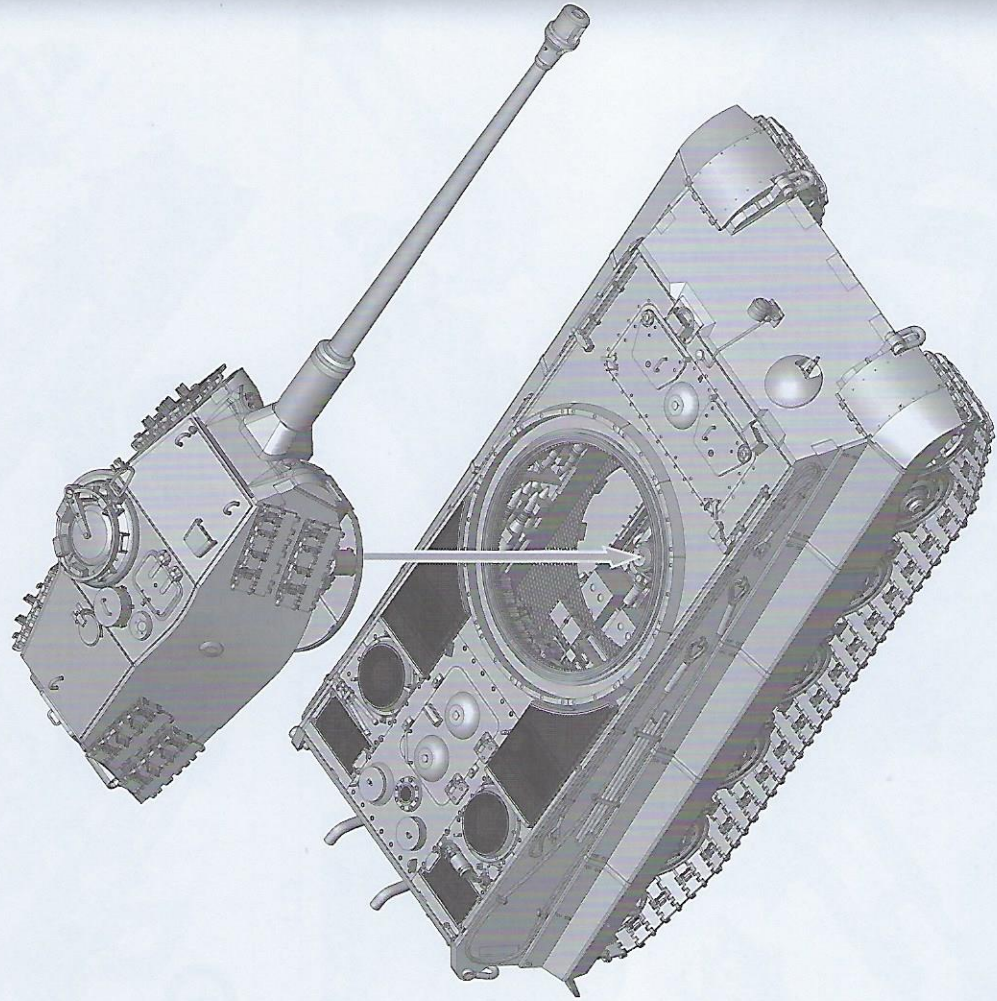

Painting and Marking Guide

- A.MIG 014 Red-brown
- A.MIG 035 Dark Tracks
- A.MIG 037 New Wood
- A.MIG 041 Dark Rust
- A.MIG 045 Gun Metal
- A.MIG 004 Old Wood
- A.MIG 002 Olivegreen Opt.2
- A.MIG 015 Schlachelbraun
- A.MIG 011 Dunkelgelb

Tiger Ausf.B, 3./s.H.Pz.Abt.503
(no 324), Mailly Le Camp,
France 07.1944.



TAKOM Sd.Kfz. 182 KingTiger Porsche Turret w/ Zimmerit Ref: 2046

Painting and Marking Guide

- A.MIG 014 Red-brown
- A.MIG 035 Dark Tracks
- A.MIG 037 New Wood
- A.MIG 041 Dark Rust
- A.MIG 045 Gun Metal
- A.MIG 004 Old Wood
- A.MIG 002 Olivegreen Opt.2
- A.MIG 015 Schlachelbraun
- A.MIG 024 Warbabbe White Camo
- A.MIG 011 Dunkelgelb

Tiger Ausf.B, 3./s.H.Pz.Abt.FHH
(no 314, commander, Uffz. Jockel),
The area west of Stuhlweissenburg,
Hungary, 22.01.1945.

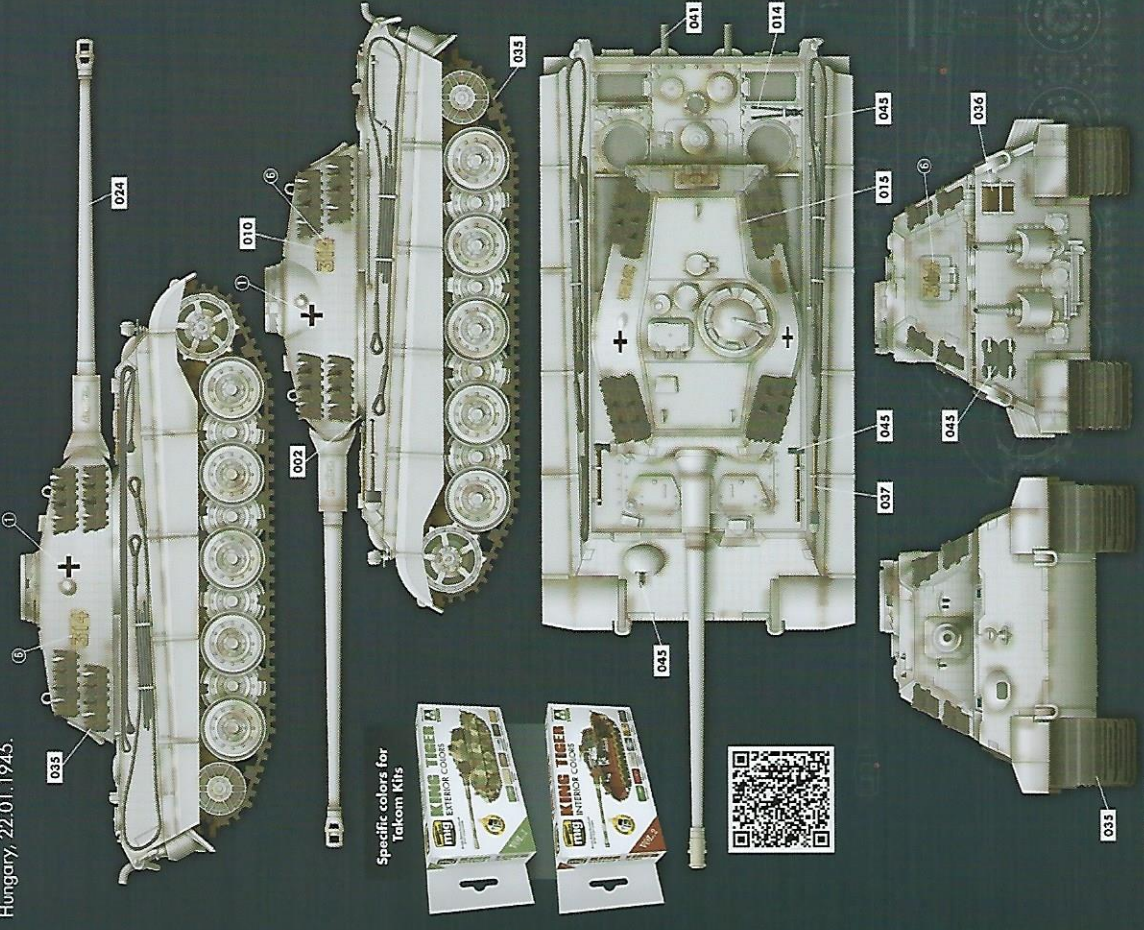

TAKOM Sd.Kfz. 182 KingTiger Porsche Turret w/ Zimmerit Ref: 2046

2016/2046

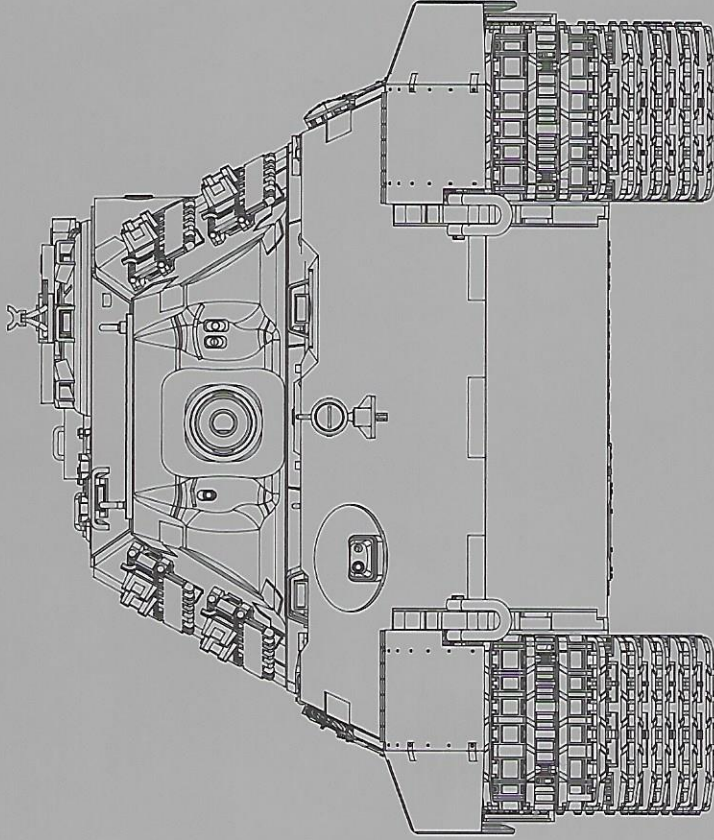

 You can find TAKOM on Facebook.com

King Tiger

..... Interior painting instruction

Henschel Turret

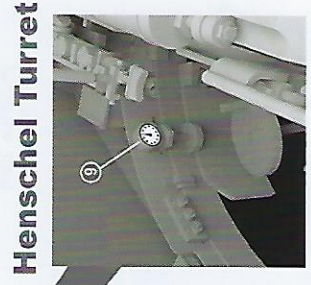
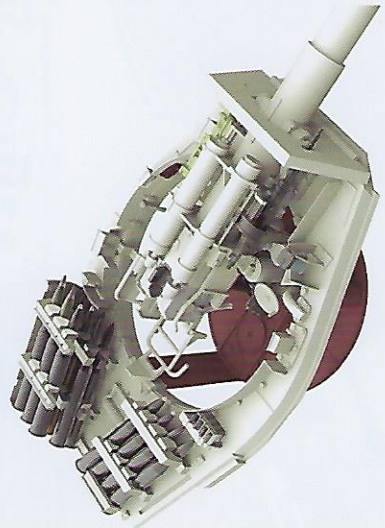

Henschel Turret

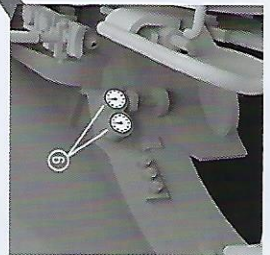
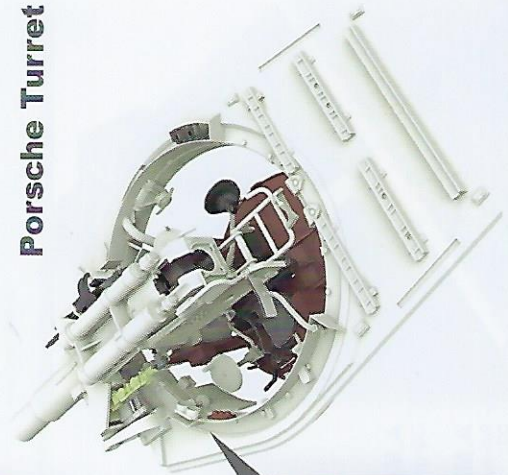

Porsche Turret



A.MIG 046
Matt Black

A.MIG 017
Cremeweiss

A.MIG 010
Dunkelgelb

A.MIG 909
Grey Light Base

A.MIG 191
Steel

A.MIG 194
Matt Aluminium

A.MIG 194
Matt Aluminium

A.MIG 032
Satin Black

A.MIG 017
Cremeweiss

A.MIG 014
Rotbraun

A.MIG 046
Matt Black

A.MIG 032
Satin Black

Porsche Turret

A.MIG 045
Gun Metal

A.MIG 014
Rotbraun

King Tiger

Interior painting instructions

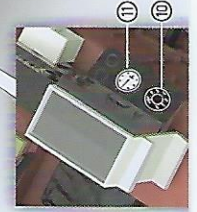
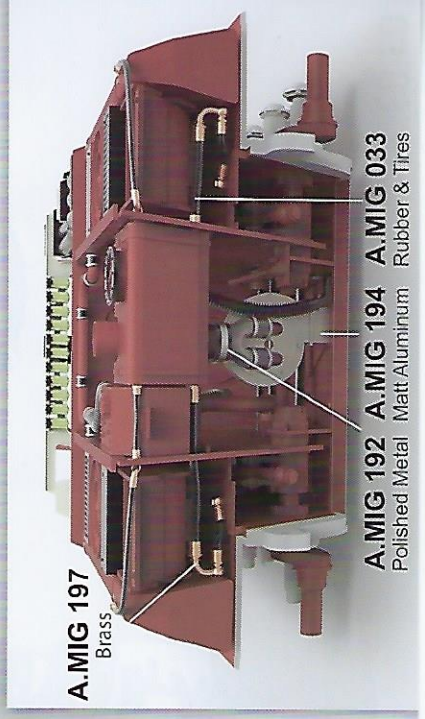
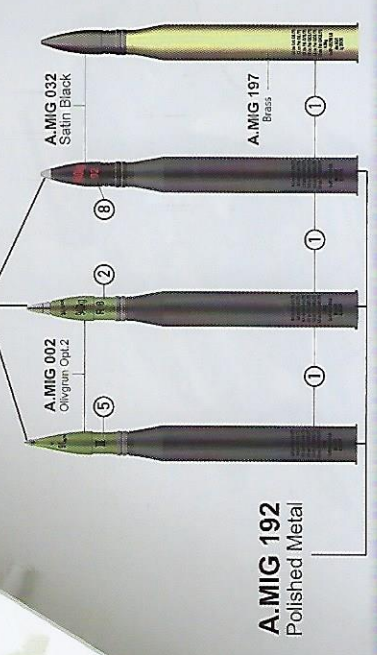
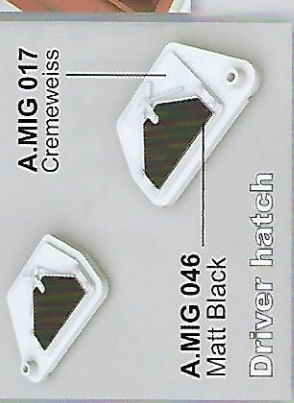
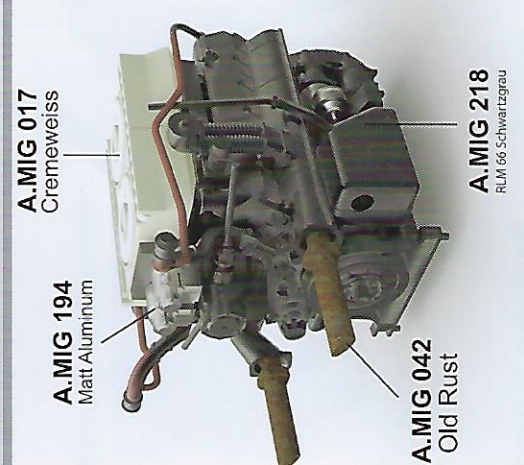
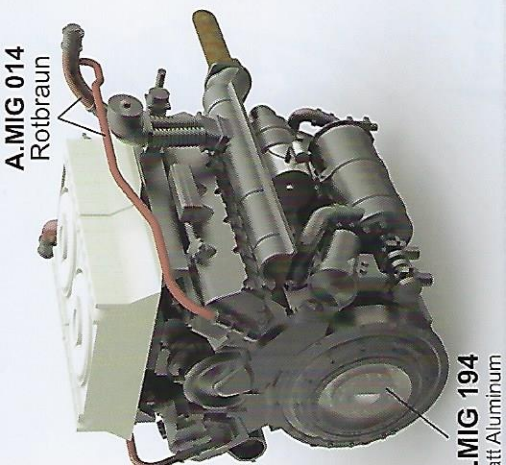
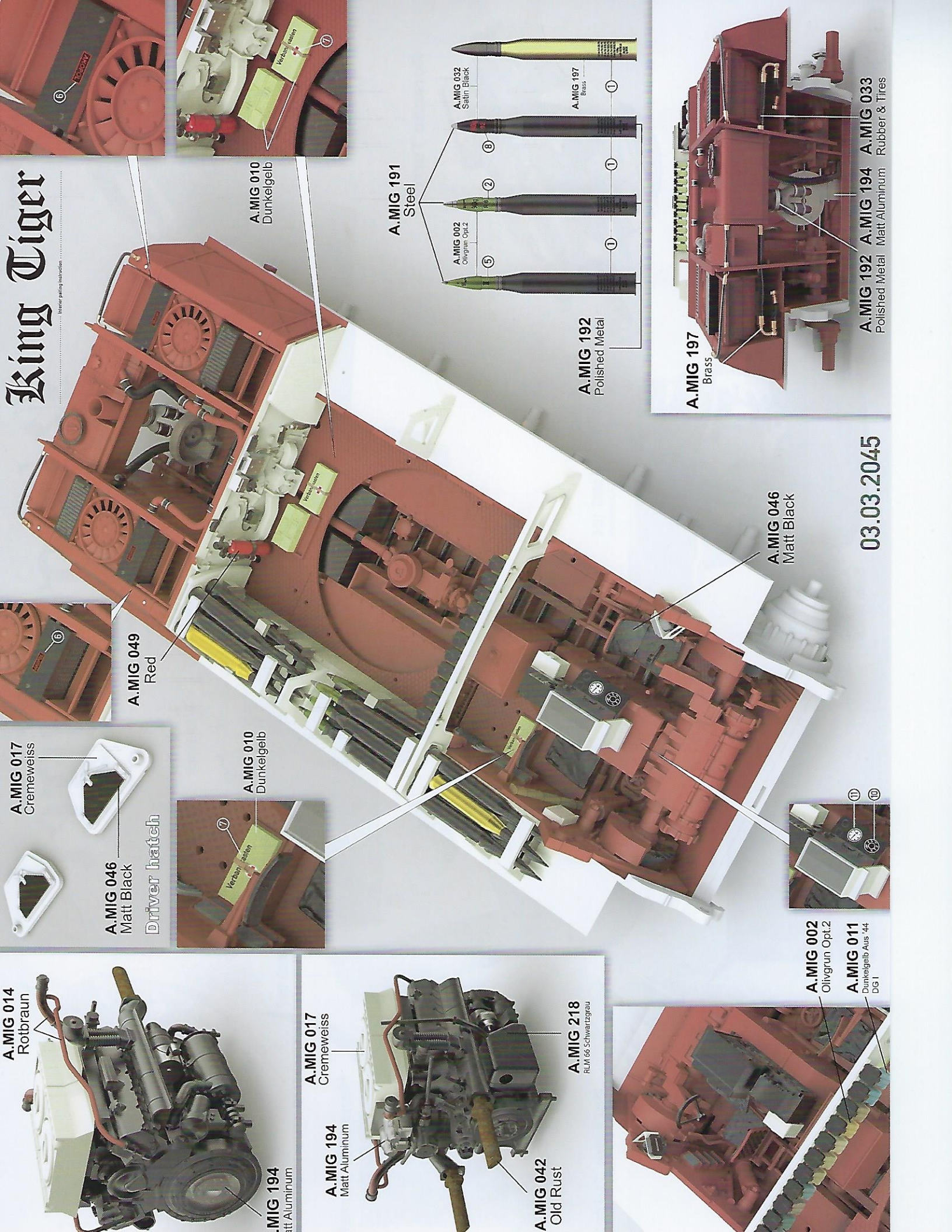

03.03.2045

PARTS

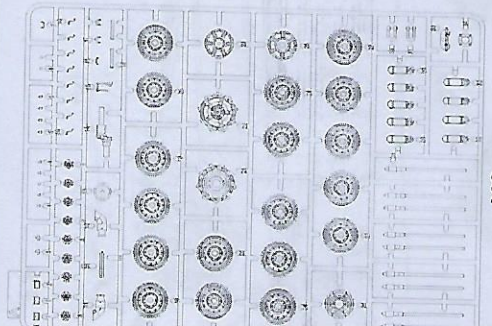

Z1

Z2

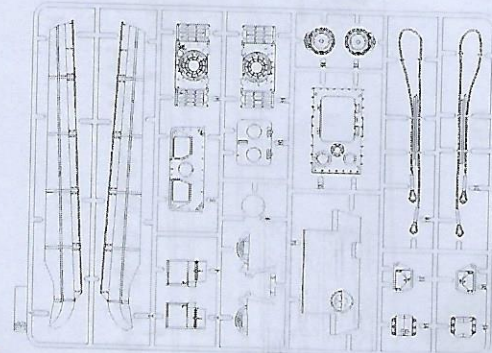

X2

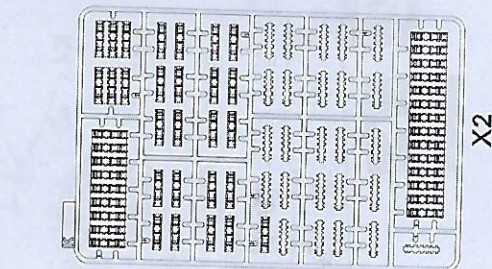
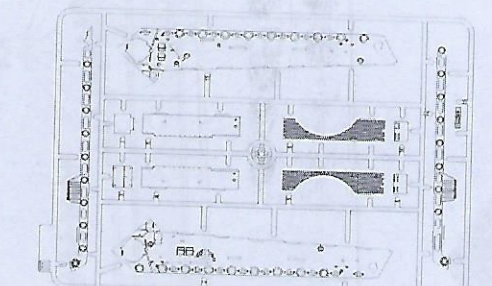
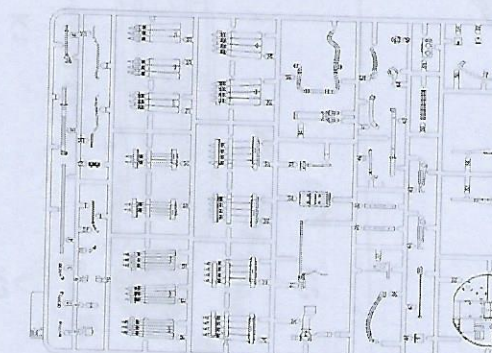
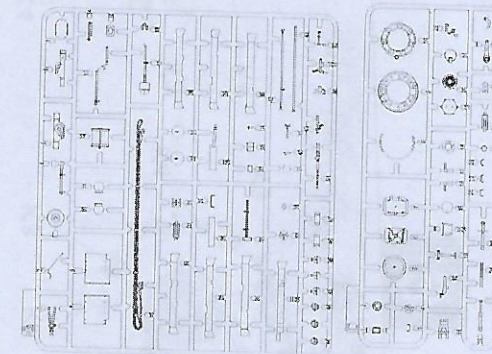

X2

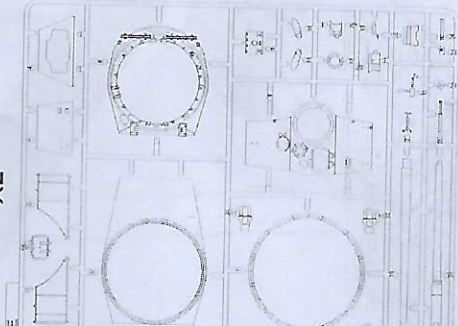

X2

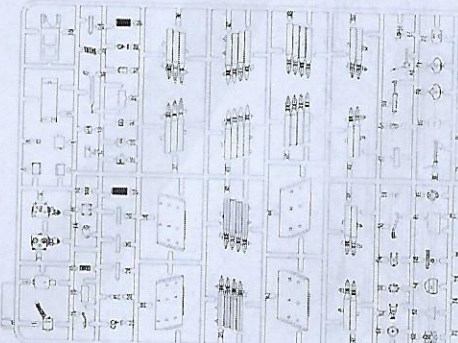
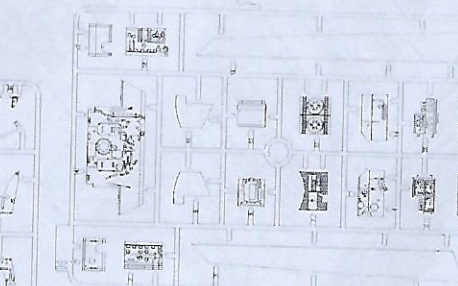
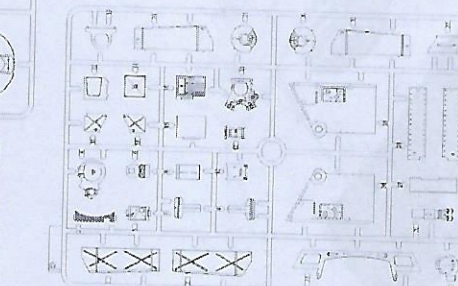
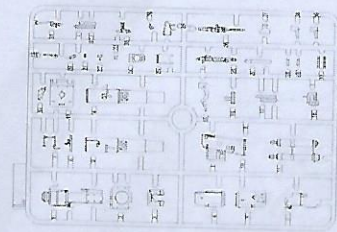
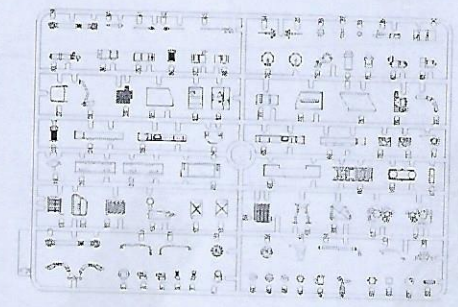

Turret



X2

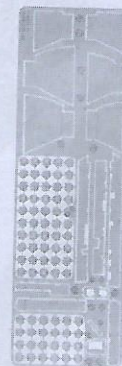

TP

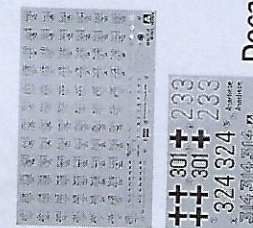

Decal

301# 238
301# 238
324 324
324 324

Lower Hull

Upper Hull

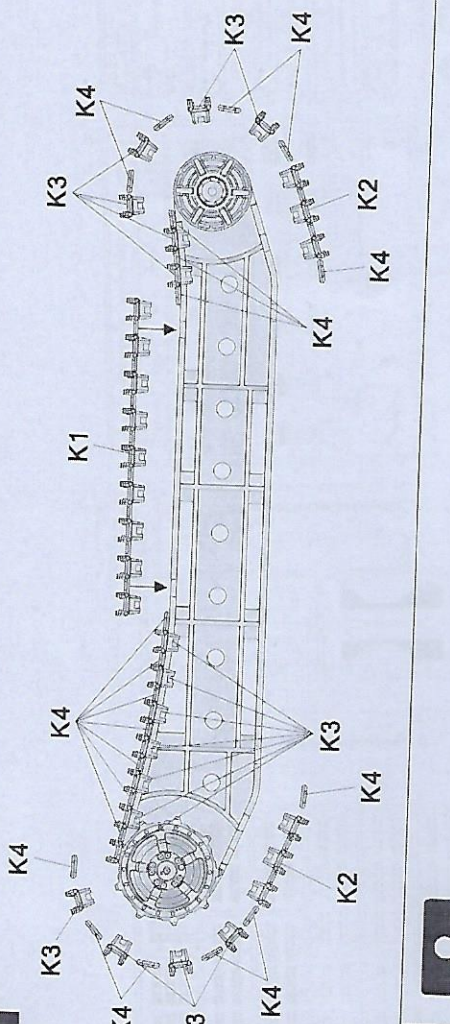
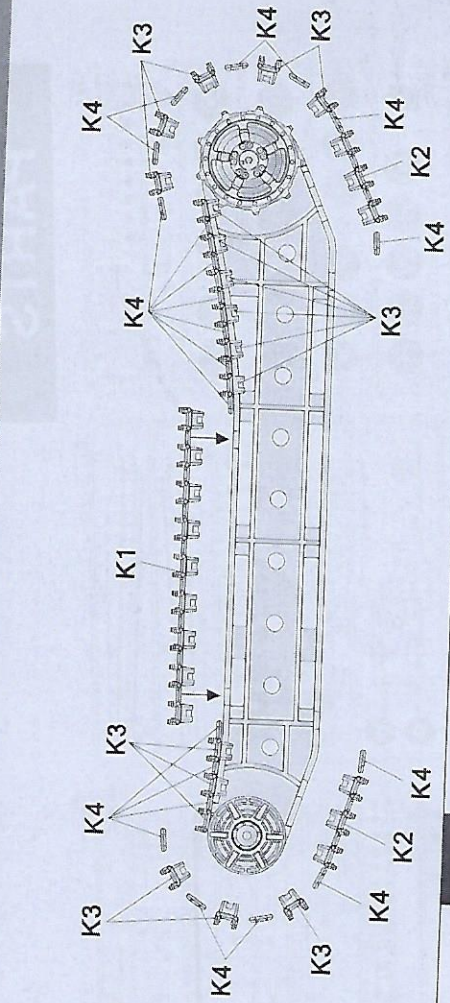

3

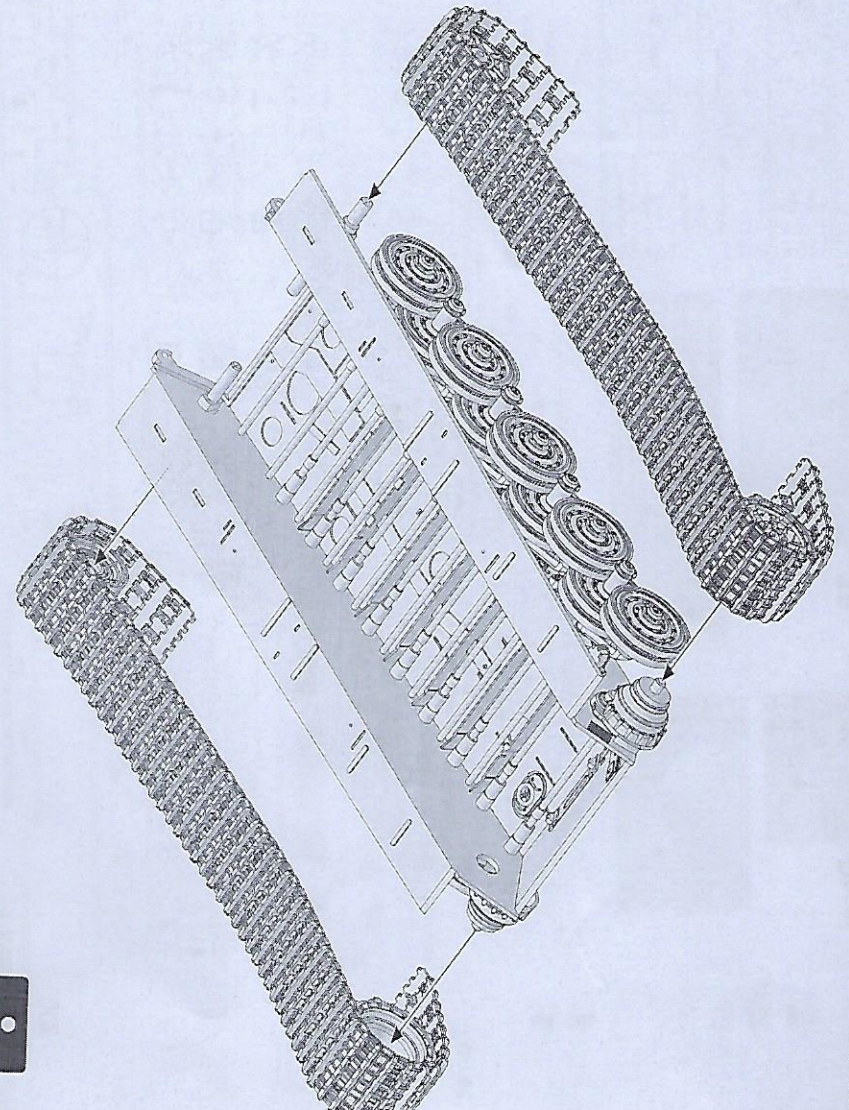
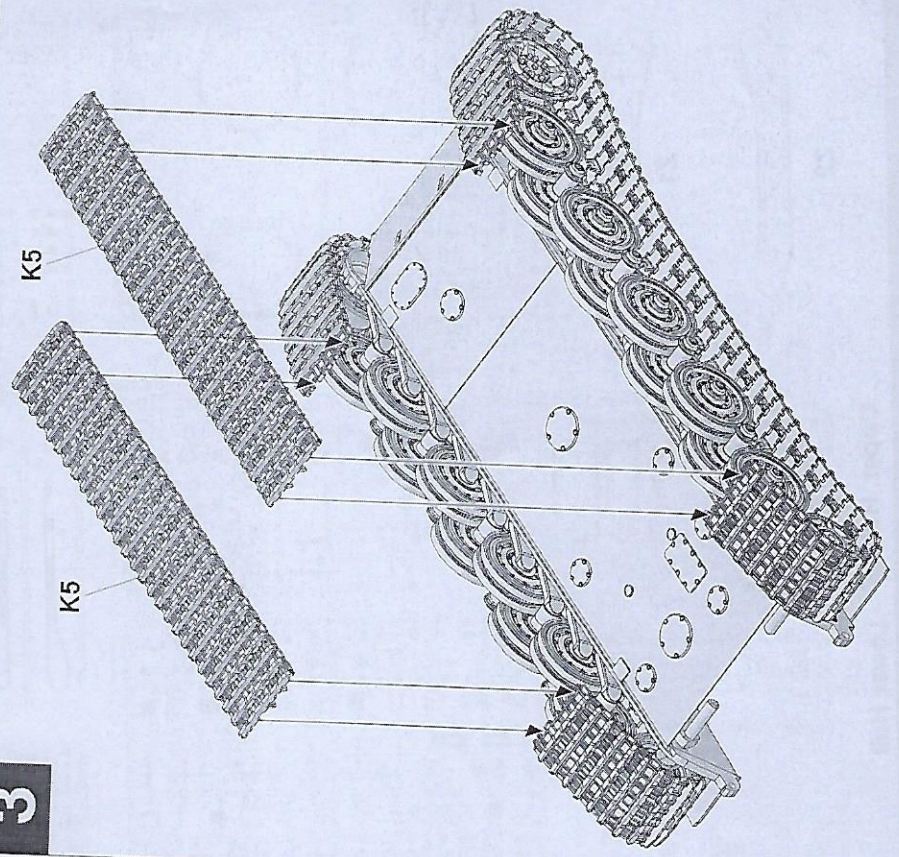

3

! Correction #2046

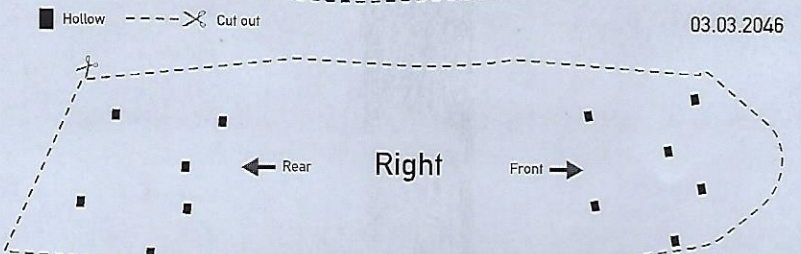
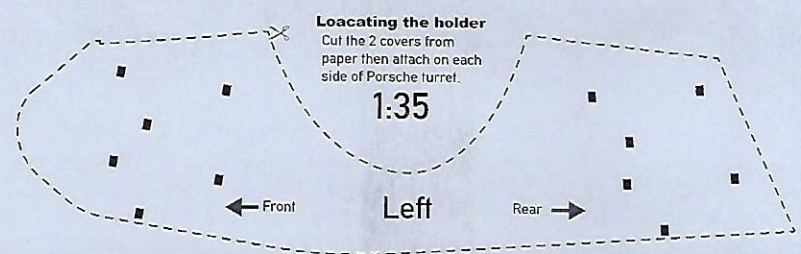
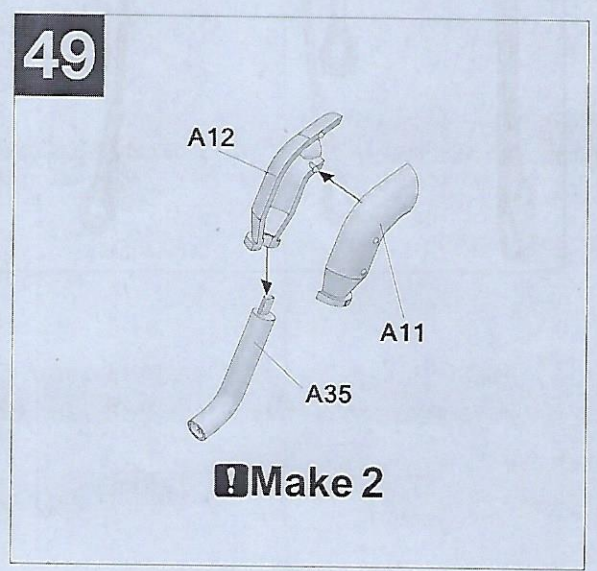
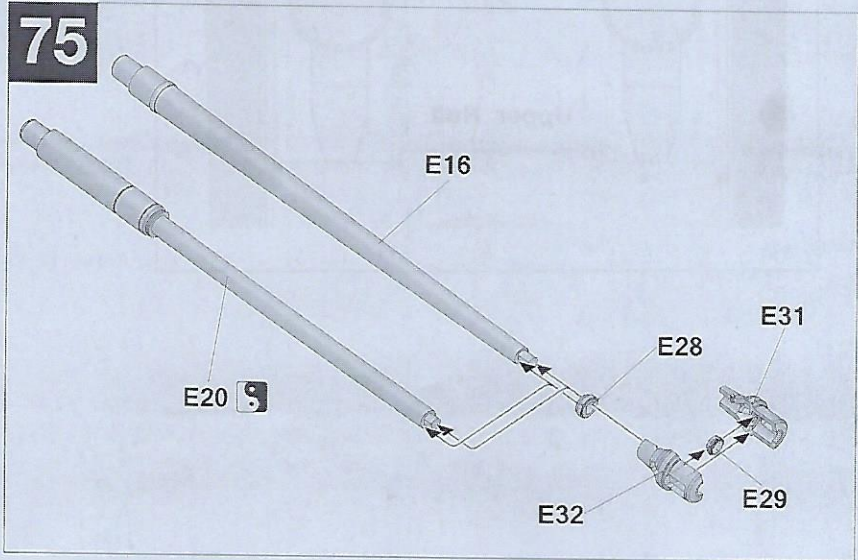
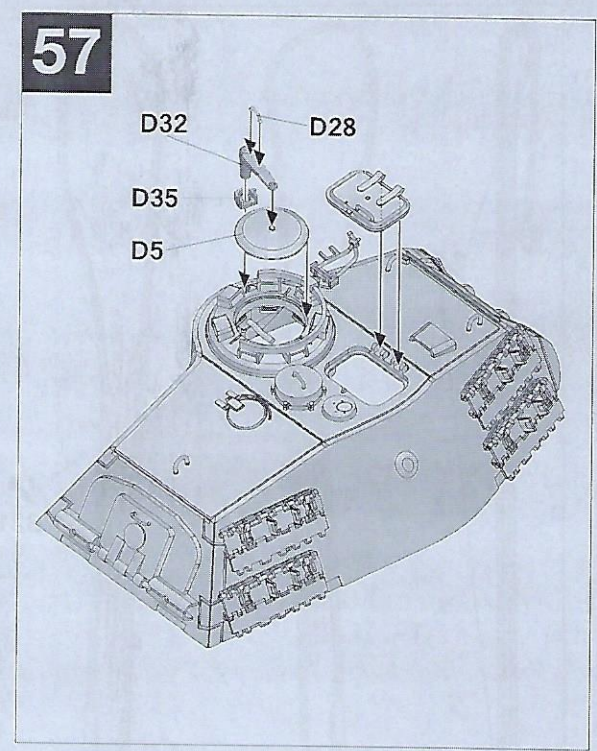
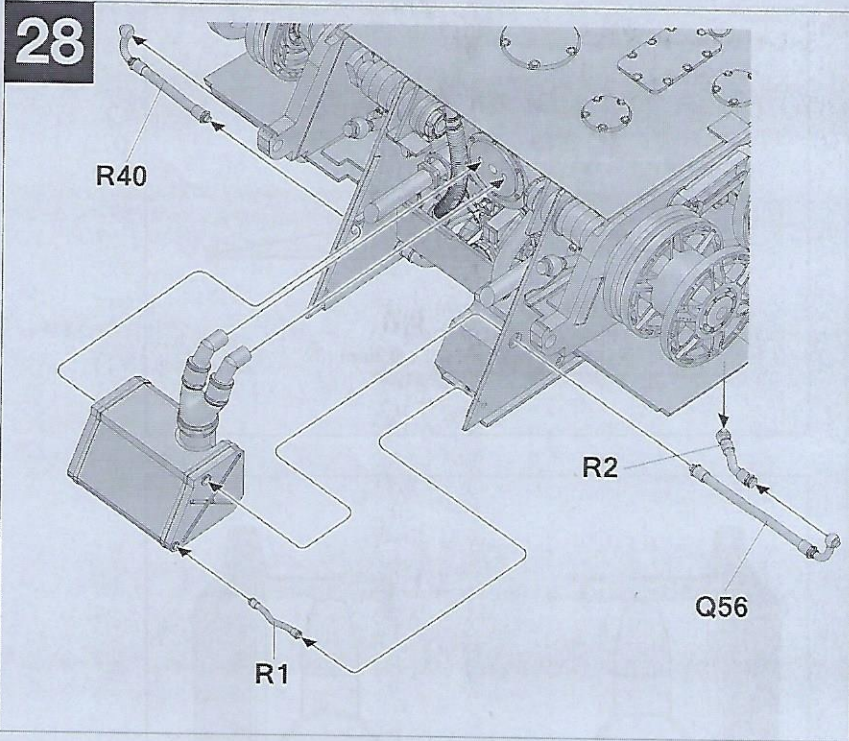

56 **58** **!** Correction #2046

