

GRUMMAN F7F-2 / 2N

TIGERCAT

STOCK No. 8844

Form No. 099 - 8844

SHEET 1 OF 2

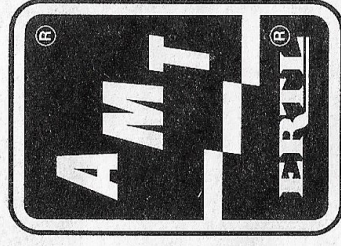

ASSEMBLY INSTRUCTIONS

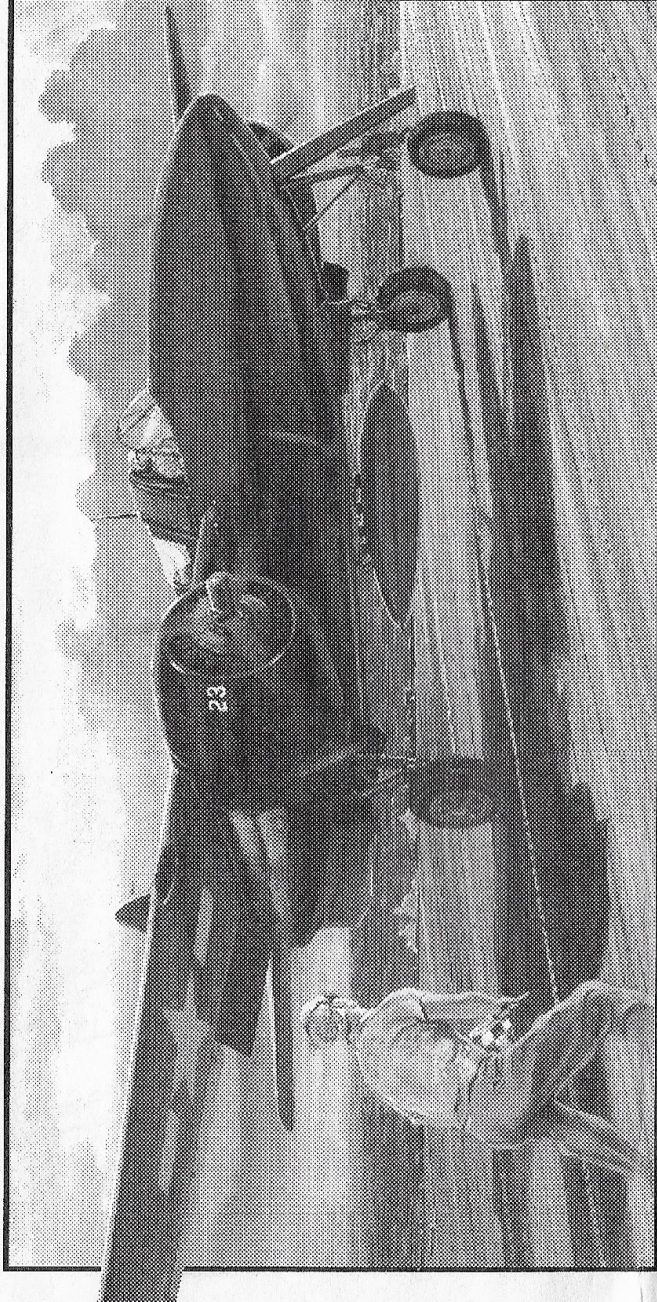

early in the production run of the F7F-1, the Navy selected Grumman to make modifications creating the model. Aircraft Bureau Number 80261, the third production -1, was modified to include a second cockpit and a radar operator via the removal of one fuselage cell. Further modification for the fitting of the APS-6 airborne radar included the deletion of the .50 caliber machine guns, although provision was made for the reinstallation of those guns for day-ear configuration. The -2N retained the standard .50 caliber wing guns and wing and fuselage ordnance bins. An 80-gallon auxiliary tank was designed to fit the rear cockpit for modification to day-fighter standard, and the complete complement of .50 caliber 20mm guns would be fitted, in addition to all bomb racks and rocket launchers.

The primary production version of the F7F-2 was the -2N night fighter. Production records are somewhat confused and, although it appears the -2 was ordered as a night fighter, photo archives verify that a number of aircraft were delivered as standard day-fighters with a metal plate fitted over the rear fuselage area of the radar operator's clear canopy. The first was flown and delivered on October 31, 1944, and the last -2N handed over to the Navy on March 8, 1945.

VMF(N)-531 was the first unit to fly the -2N. After a period of work-up, the unit shipped out for combat duty in the Pacific on July 24, 1945. The ship was nearing Guam when the first atomic bomb was dropped on Hiroshima. Upon arrival at Guam, the unit flew to Okinawa via Iwo Jima in preparation for action, arriving the day before WWII ended. In October, aircraft from VMF(N)-531 were ordered to China in a "show the flag" operation, where they remained as part of VMF(N)-533, flying armed reconnaissance missions until early 1947.

Your AMT kit provides you with the opportunity to build a highly-detailed replica of either the F7F-2 or F7F-2N. Markings for -2 Tigercats are almost painfully dull, consisting essentially of stars and bars. AMT provides you with markings for two F7F-2Ns. One aircraft, in an all-yellow scheme, is from the Naval Air Test Center at Patuxent (Pax River), circa 1950. The other scheme represents an aircraft from VF(N)-52 during carrier qualification operations on the U.S.S. Antietam on April 8, 1945.

We hope you enjoy building this fine kit.

IMPORTANT

Before you begin to assemble your model kit, study the instructions carefully and check to be sure you have received the parts that you will need. This will help you to familiarize yourself with the parts and their locations as you need. Prior to cementing parts together, be sure to "TEST" them in order to assure proper alignment and also to look for excess "FLASH" that may occur along parting lines. A sharp hobby knife or file to remove flash if necessary. If you wish to paint your model, various sub-assemblies and components should be painted before any parts are attached. During assembly, you may note that often the recommended is stated after the part name.

This model kit is molded from the finest high-impact styrene plastic. **Use only paints and cements which are specifically formulated for styrene. Read all cautions and warning labels fully.**

Because the cement will only adhere to bare plastic, it is necessary to remove any paint or "plating" from the area to which the cement is to be applied.

BUILDING TIPS FOR THE ADVANCED MODELER

For the best possible finish, your kit should be painted, even blended in color. Paint should be applied evenly, in several coats rather than one heavy coat. The first coat should not completely cover the surface. Each layer should be allowed to thoroughly dry before the next is applied.

It is important to keep your hands clean when working with model and wash parts thoroughly before painting to remove any mold release agent that may have been used during manufacture, body oil from your hands, sanding residue, and which is naturally attracted to plastic by static electricity. Use a mild solution of dish washing detergent and water. Dry your hands with a soft towel. A tack rag should be used to remove lint or dust before painting.

Parting lines and glue joints should be sanded or filed prior to painting. Because paint has a tendency to fill away from sharp edges, they should be lightly filed. Use filler putty designed for plastic to fill small gaps that may occur between parts and to blend contours. This should be done only after the first, or "primer," coat of paint is applied. Be careful not to remove any detail while sanding. When painting a multi-color scheme, the lightest color should be painted first. Use frosted, or "magic," tape to mask off the area you do not want painted. After the second color is dry to the touch, the tape can be removed. Use a very fine brush to touch up edges if necessary. If decals are to be added, do so after adding a clear coat. A final clear coat will help even out the edges between the two colors as well as set the decals.

NOTE: Federal standard colors The military services use standardized colors, each receiving a specific five digit identification number. Grays, for instance, are all 6000, and gloss paints begin with a 1, semi-gloss 2, and flat 3. Thus a gray color can be gloss (16251), semi-gloss (26251) or flat (36251).

RECOMMENDED TOOLS

HOBBY KNIFE

Use a sharp hobby knife to remove parts from the trees. The knife may also be used to remove parting lines and flash.

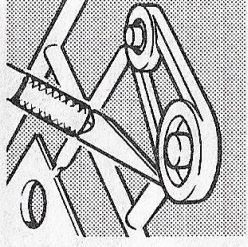

TWEEZERS

Use tweezers to hold smaller parts during assembly, painting and when applying cement.

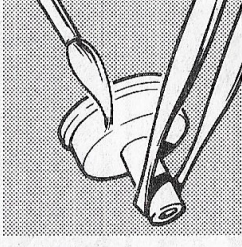

BRUSH

We recommend the use of liquid polystyrene cement. Apply with a fine brush. Use cement sparingly or a sloppy job will result.

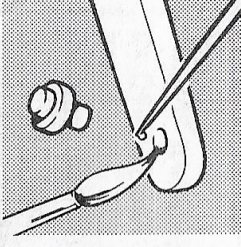

READ ALL LABELS AND WARNINGS CAREFULLY

Customer satisfaction is a priority at Ertl. Should a problem occur with this product, call us toll free: 1-800-553-4886



COCKPIT ASSEMBLY

PILOTS COCKPIT ASSEMBLY

- A: Cement the PILOT SEAT to the COCKPIT BULKHEAD.
- B: Cement the COCKPIT BULKHEAD to the COCKPIT FLOOR.
- C: Paint this assembly *Interior Green* as a unit.
- D: Paint the INSTRUMENT PANEL and the CONTROL STICK as indicated.
- E: Cement the INSTRUMENT PANEL and the CONTROL STICK to the COCKPIT FLOOR.

IMPORTANT

VERSION 1: Paint all parts *Dark Sea Blue* (FS.-15042) unless stated otherwise. (Ref. DECAL SUPPLEMENT)

VERSION 2: Paint all parts *Gloss Yellow* (FS.-13538) unless stated otherwise. (Ref. DECAL SUPPLEMENT)

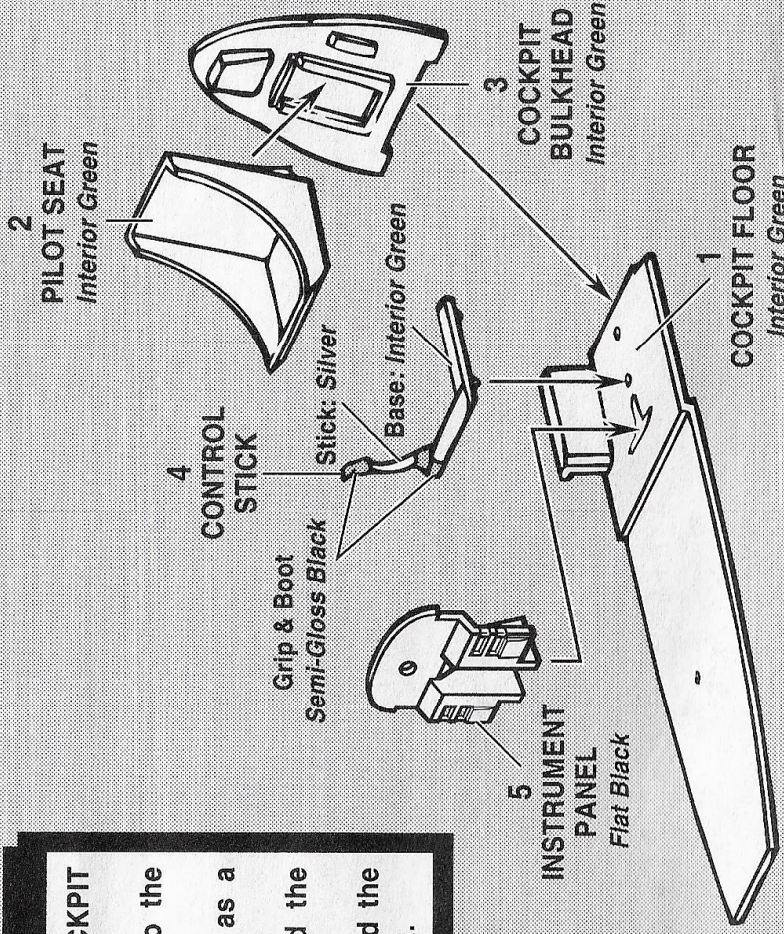

RADAR OPERATOR'S COCKPIT ASSEMBLY

- A: Cement the AFT BULKHEAD, both AFT COCKPIT WALLS and the RADAR PANEL to the AFT COCKPIT FLOOR.
- B: Paint this assembly *Interior Green* as a unit.
- C: Paint the RADAR HOOD and the RADAR PANEL as indicated.
- D: Cement the RADAR HOOD and the RADAR PANEL to the AFT COCKPIT FLOOR.

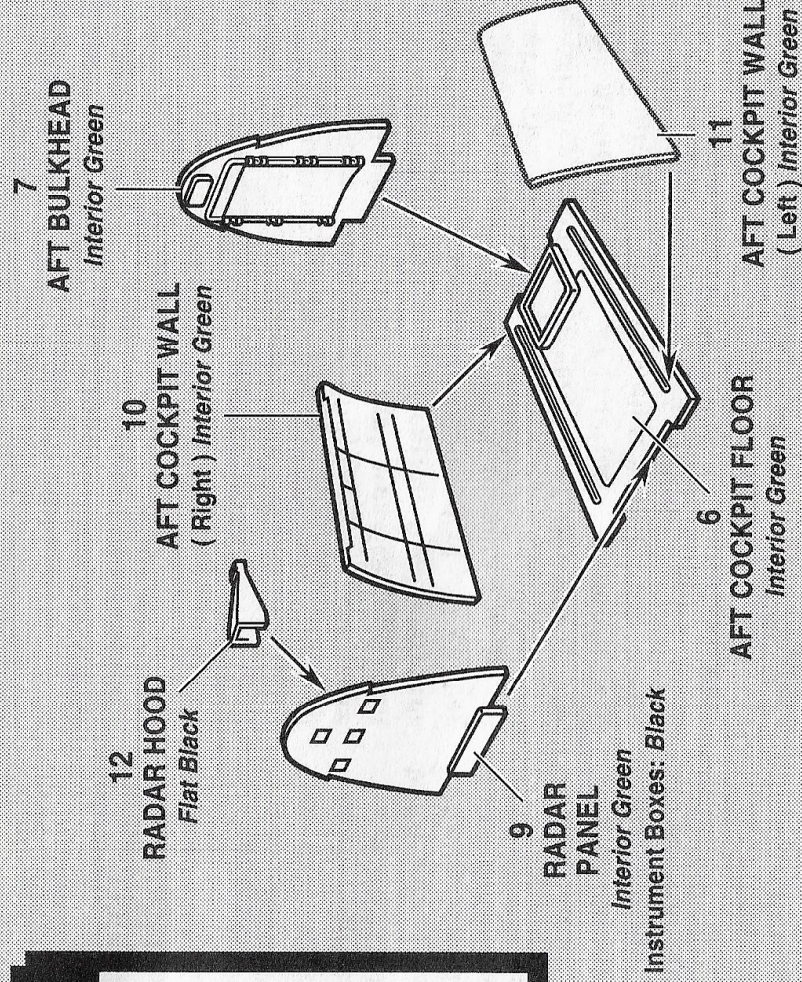

ENGINE ASSEMBLY

ENGINE ASSEMBLY

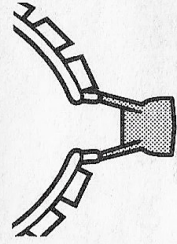

- A: Carefully trim away excess material (*Shaded Area*) from both IGNITION HARNESSSES.
- B: Cement one Front and one Rear CYLINDER ASSEMBLY together as shown and paint *Gray* as indicated.
- C: Paint the rest of the parts shown in this assembly as indicated prior to assembly.
- D: Slip (DO NOT CEMENT) the PROPELLER RETAINER through the CRANKCASE.

- E: Press the PROPELLER onto the RETAINER.
- F: Cement one IGNITION HARNESS and one FIREWALL to the CYLINDER ASSEMBLY.
- G: Cement the ENGINE COWL and the FIREWALL together.
- H: Cement the CRANKCASE to the front of the CYLINDER ASSEMBLY.

NOTE: ASSEMBLE 2 ENGINES AS SHOWN

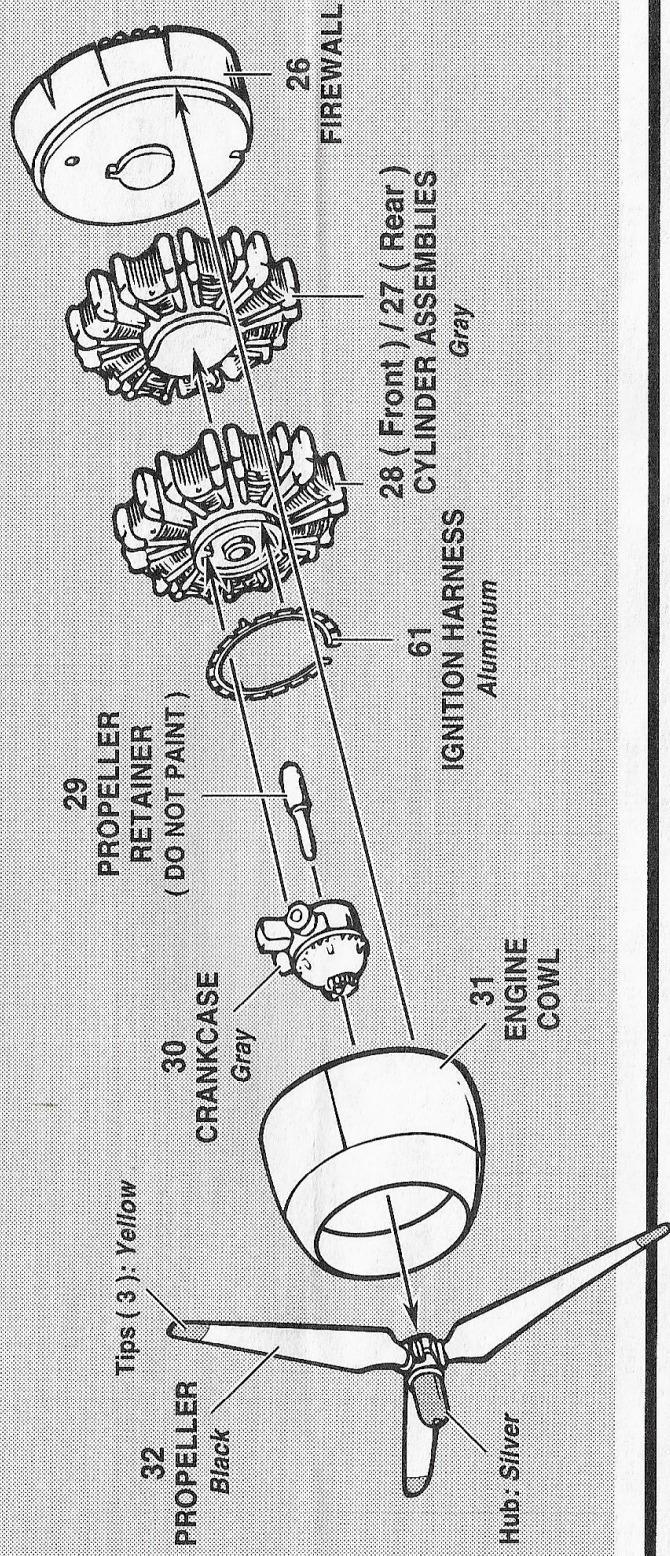

FUSELAGE ASSEMBLY

PILOT'S COCKPIT ASSEMBLY

- A: Paint the interior of both FUSELAGE HALVES *Interior Green* at both the NOSE GEAR and COCKPIT locations (*Shaded Areas*)
- B: Carefully cement the ASSEMBLED PILOT'S and RADAR OPERATOR'S COCKPITS to either FUSELAGE HALF.

- C: Cement both FUSELAGE HALVES together.
- D: Cement 2 SWAY BRACES to the bottom of the FUSELAGE as shown.

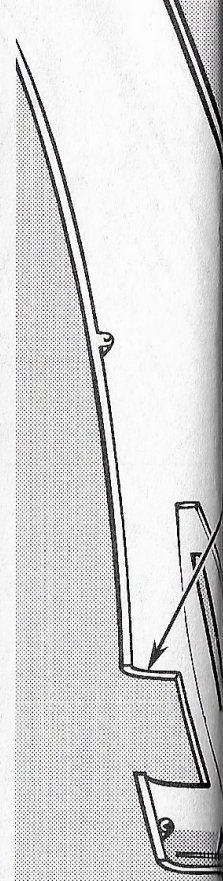

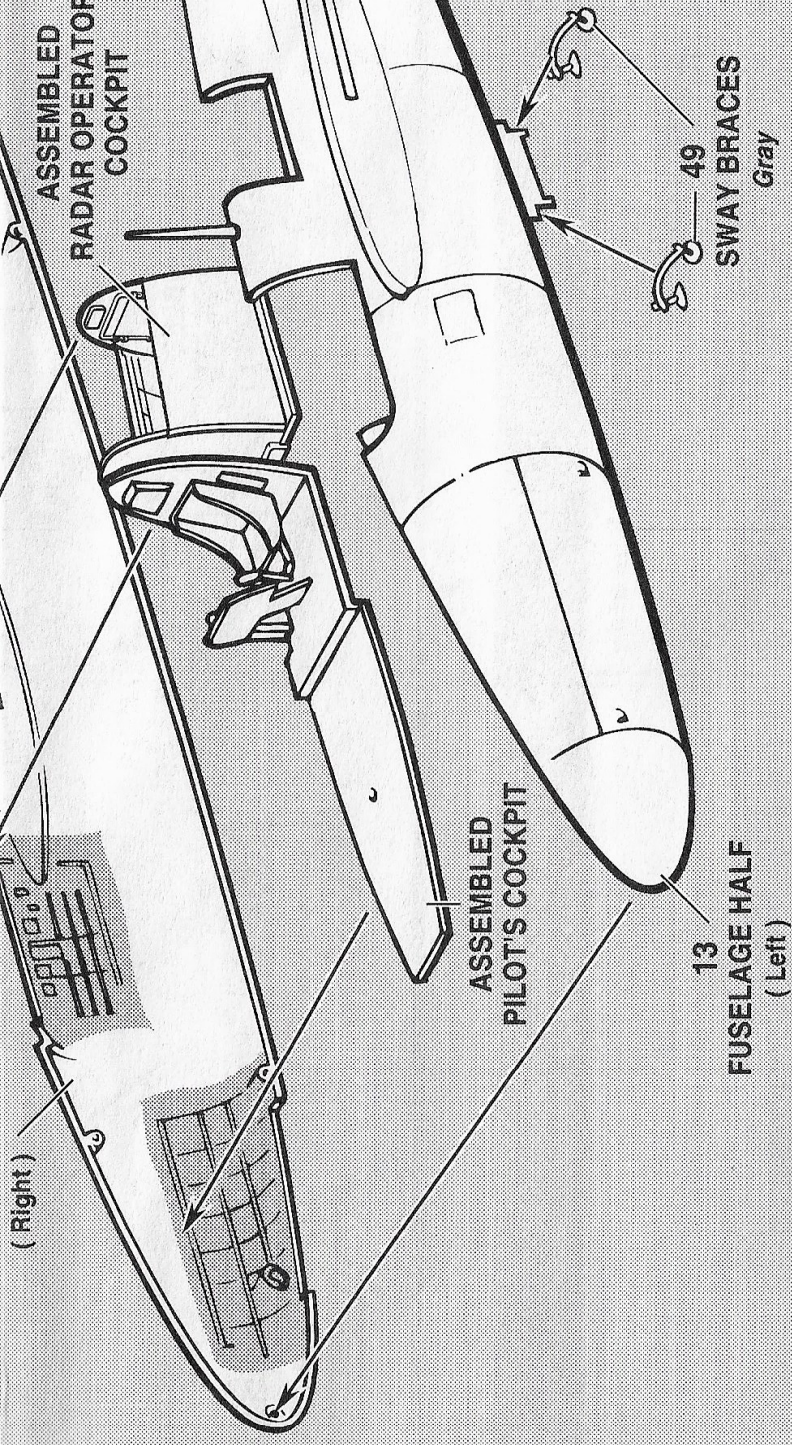

HORIZONTAL STABILIZER ASSEMBLY

LEFT HORIZONTAL STABILIZER ASSEMBLY

A: Cement both halves of the left HORIZONTAL STABILIZER together as shown.

33 LEFT HORIZONTAL STABILIZER (Upper)

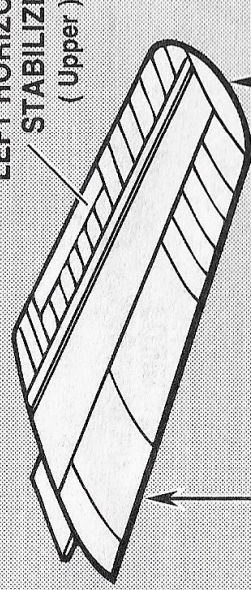

35 LEFT HORIZONTAL STABILIZER (Lower)

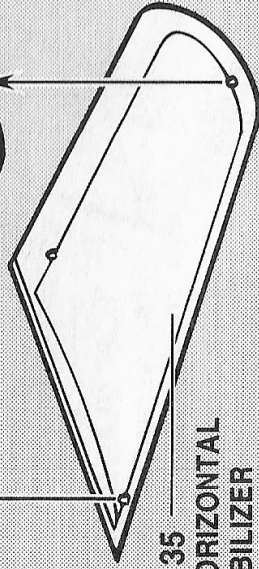

RIGHT HORIZONTAL STABILIZER ASSEMBLY

A: Cement both halves of the Right HORIZONTAL STABILIZER together as shown.

34 RIGHT HORIZONTAL STABILIZER (Upper)

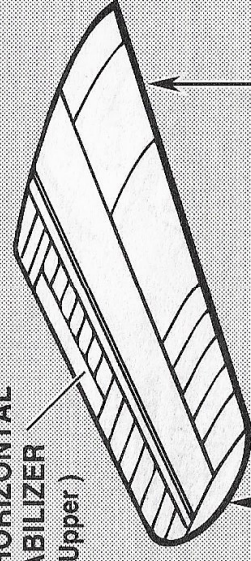

36 RIGHT HORIZONTAL STABILIZER (Lower)

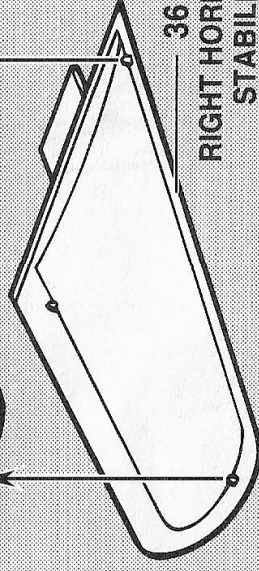

CENTERLINE FUEL TANK ASSEMBLY

CENTERLINE TANK ASSEMBLY

A: Cement both halves of the CENTERLINE FUEL TANK together as shown.

47
CENTERLINE FUEL TANK
(Upper)

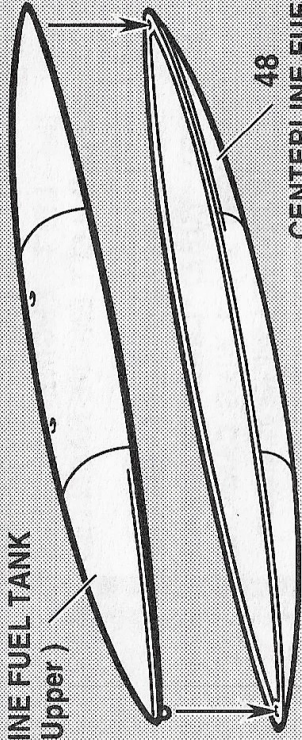

48
CENTERLINE FUEL TANK
(Lower)

ORDINANCE ASSEMBLY (VERSION 1 ONLY)

ROCKET ASSEMBLY

A: Cement both sections of the ROCKET together as shown.

NOTE: ASSEMBLE 8 ROCKETS AS SHOWN

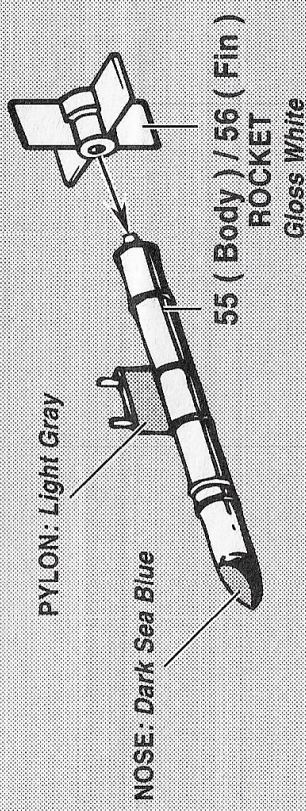

BOMB ASSEMBLY

A: Cement both sections of the BOMB together as shown.

B: Cement 2 SWAY BRACES to a BOMB PYLON as shown.

C: Cement the BOMB PYLON to the BOMB.

NOTE: ASSEMBLE 2 BOMBS AS SHOWN

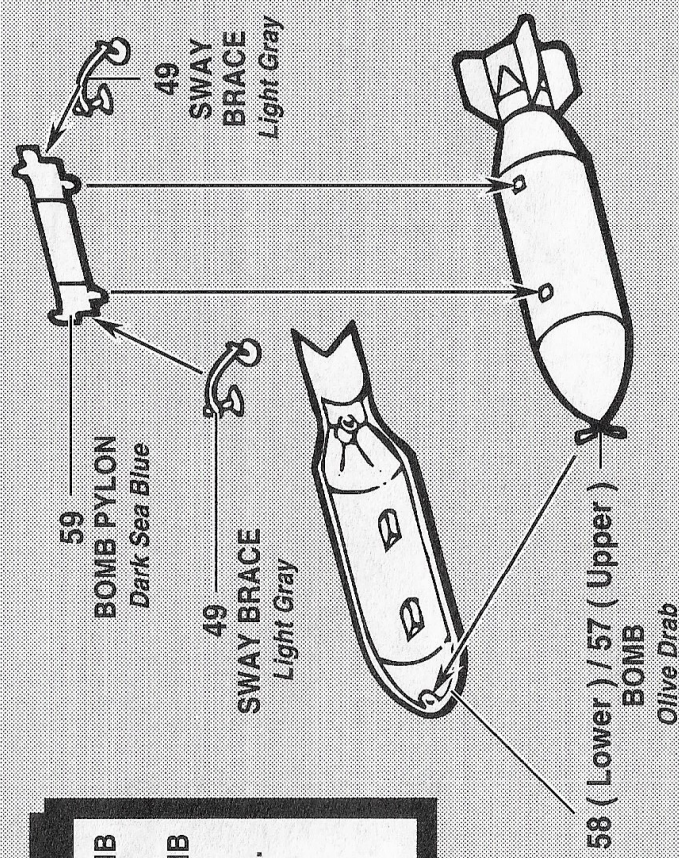

WING ASSEMBLY

LEFT WING SUB-ASSEMBLY A

- A: Carefully open the holes in the Lower LEFT WING as indicated.
- B: Cement both halves of the LEFT WING together as shown.

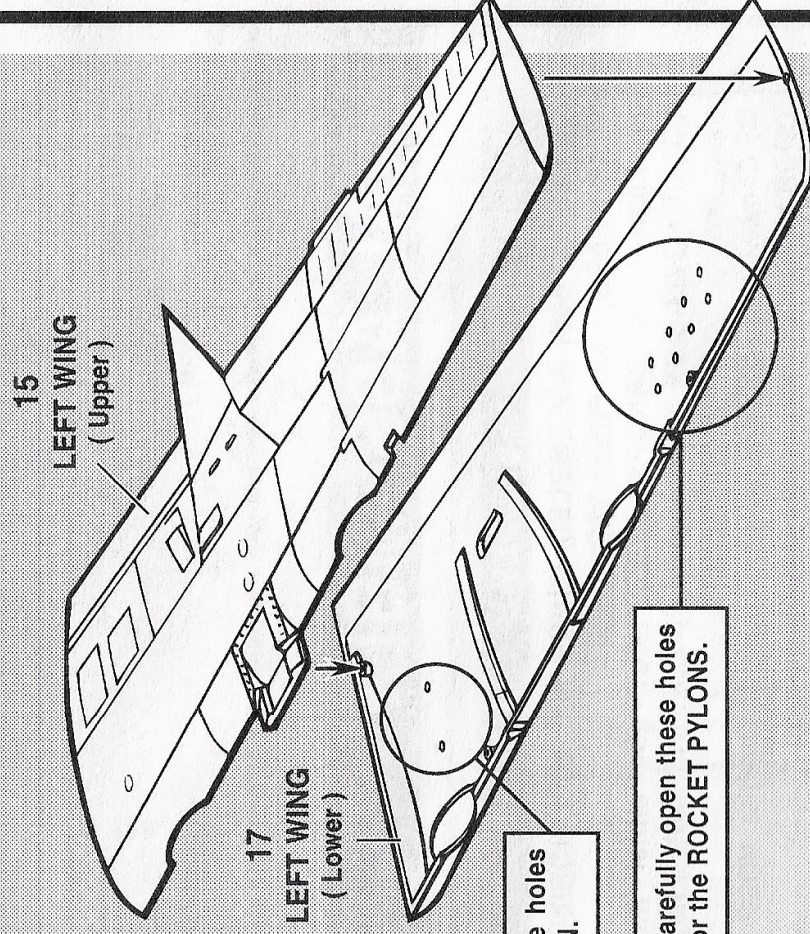

RIGHT WING SUB-ASSEMBLY A

- A: Carefully open the holes in the Lower RIGHT WING as indicated.
- B: Cement both halves of the RIGHT WING together as shown.

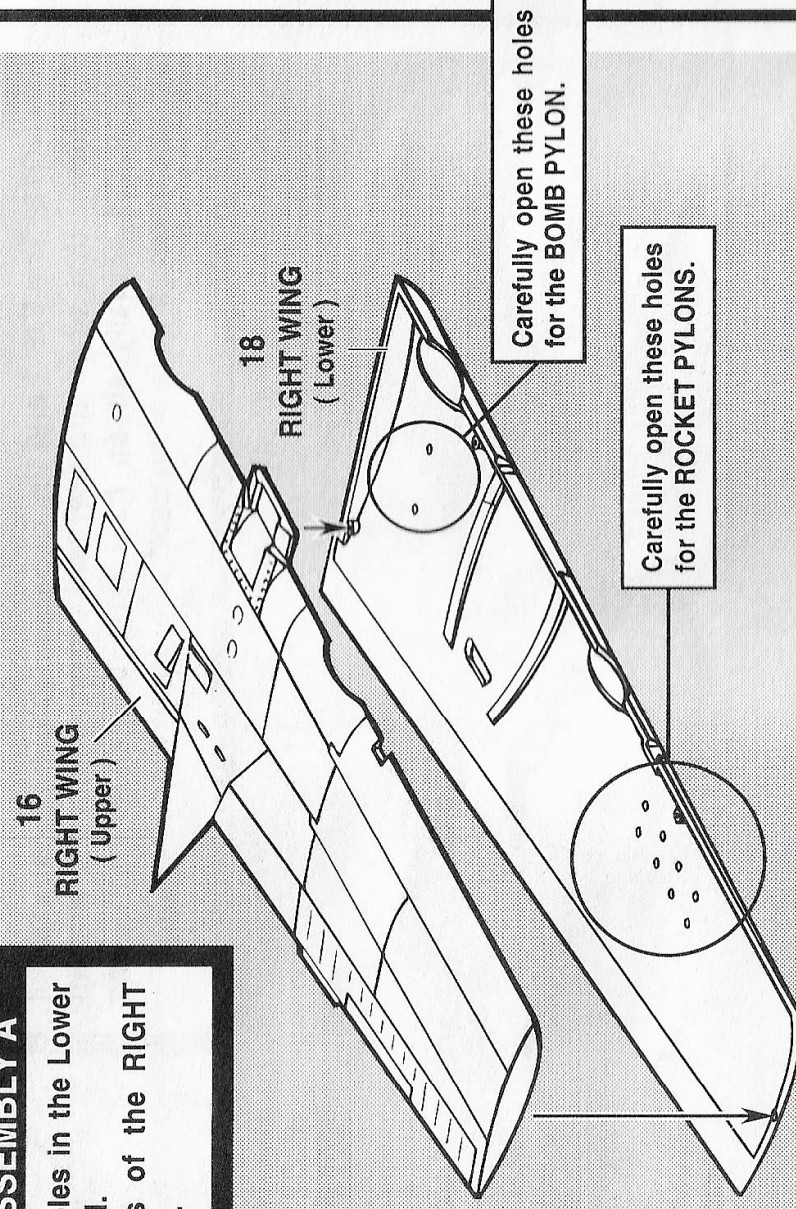

WING ASSEMBLY

LEFT WING SUB-ASSEMBLY B

A: Cement the LEFT ENGINE NACELLE BULKHEAD and both LEFT ENGINE NACELLES together as shown.

B: Cement the assembled LEFT ENGINE NACELLE, PITOT TUBE, LANDING LIGHT, LEADING EDGE LIGHT and 2 WING CANNONS to the SUB-ASSEMBLED LEFT WING as shown.

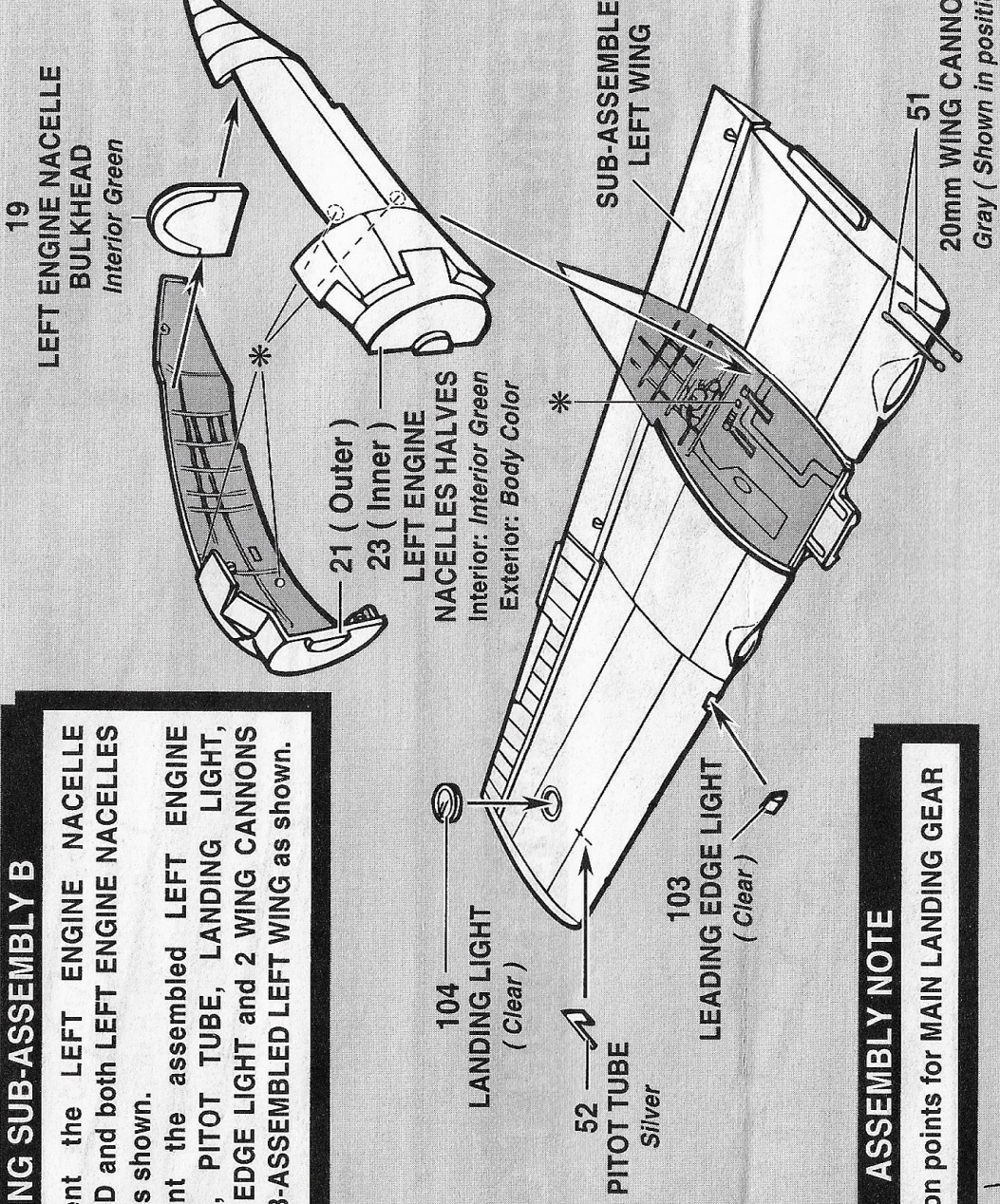

ASSEMBLY NOTE

*= Location points for MAIN LANDING GEAR

20

RIGHT ENGINE NACELLE BULKHEAD *Interior: Green*

RIGHT WING SUB-ASSEMBLY B

A: Cement the RIGHT ENGINE NACELLE BULKHEAD and both RIGHT ENGINE NACELLES together as shown.

B: Cement the assembled RIGHT ENGINE NACELLE and 2 WING CANNONS to the SUB-ASSEMBLED RIGHT WING as shown.

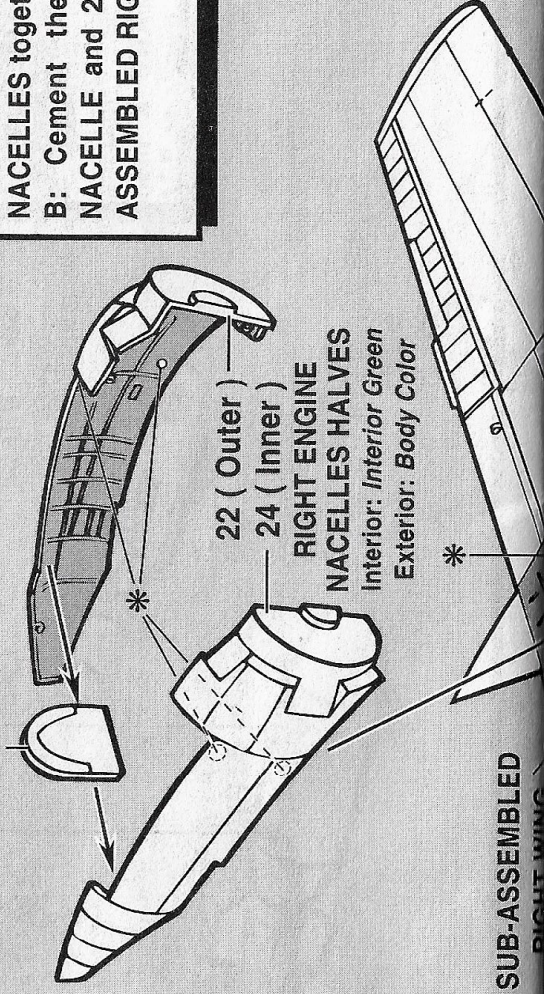

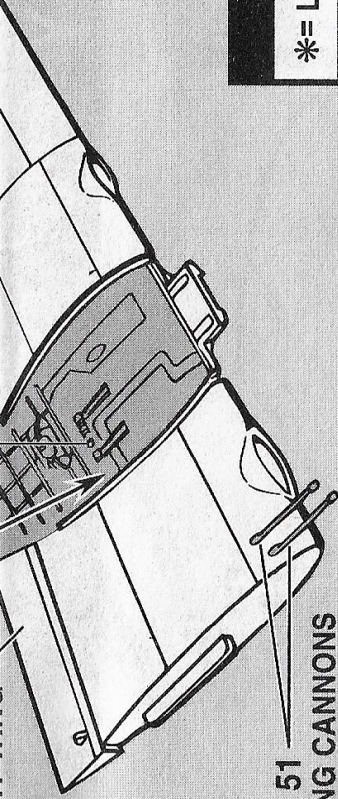

51
20mm WING CANNONS
Gray (Shown in position)

ASSEMBLY NOTE

*= Location points for MAIN LANDING GEAR

FINAL ASSEMBLY

LEFT WING SUB-ASSEMBLY B

- A: Cement both ASSEMBLED WINGS and both HORIZONTAL STABILIZERS to the FUSELAGE.
- B: Cement the CANOPY, WINDSHIELD and either the AFT CANOPY (VERSION 1) or the AFT COVER (VERSION 2) in place as shown.
- C: Cement the ASSEMBLED NOSE GEAR and the NOSE GEAR DOOR together.
- D: Cement the NOSE GEAR ASSEMBLY in place.
- E: Cement the LADDER to the indentation below and behind the WING on the left side of the FUSELAGE.
- F: Cement both halves of the TAIL STAND together and paint as

NOTE: The F7F-2 and the F7F-2N TIGERCATS were so tail heavy that when the fuel tanks were empty the aircraft would actually sit on their tails. 55 gallon drums and wood boxes were often used to prop up the tail section.

ASSEMBLED
RIGHT HORIZONTAL
STABILIZER

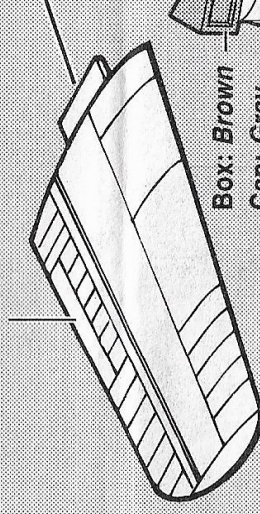

Box: Brown
Can: Gray

53 (Right)
TAIL S

ASSEMBLED
RIGHT WING

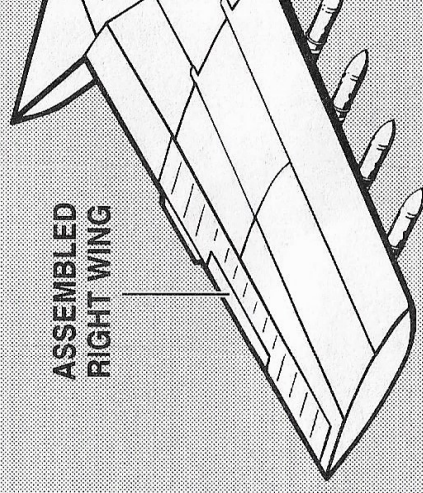

LEFT WING FINAL ASSEMBLY

A: Cement the ASSEMBLED LEFT ENGINE NACELLE, LEFT MAIN LANDING GEAR, 1 BOMB, 4 ROCKETS and both LEFT MAIN LANDING GEAR DOORS to the SUB-ASSEMBLED LEFT WING as shown.

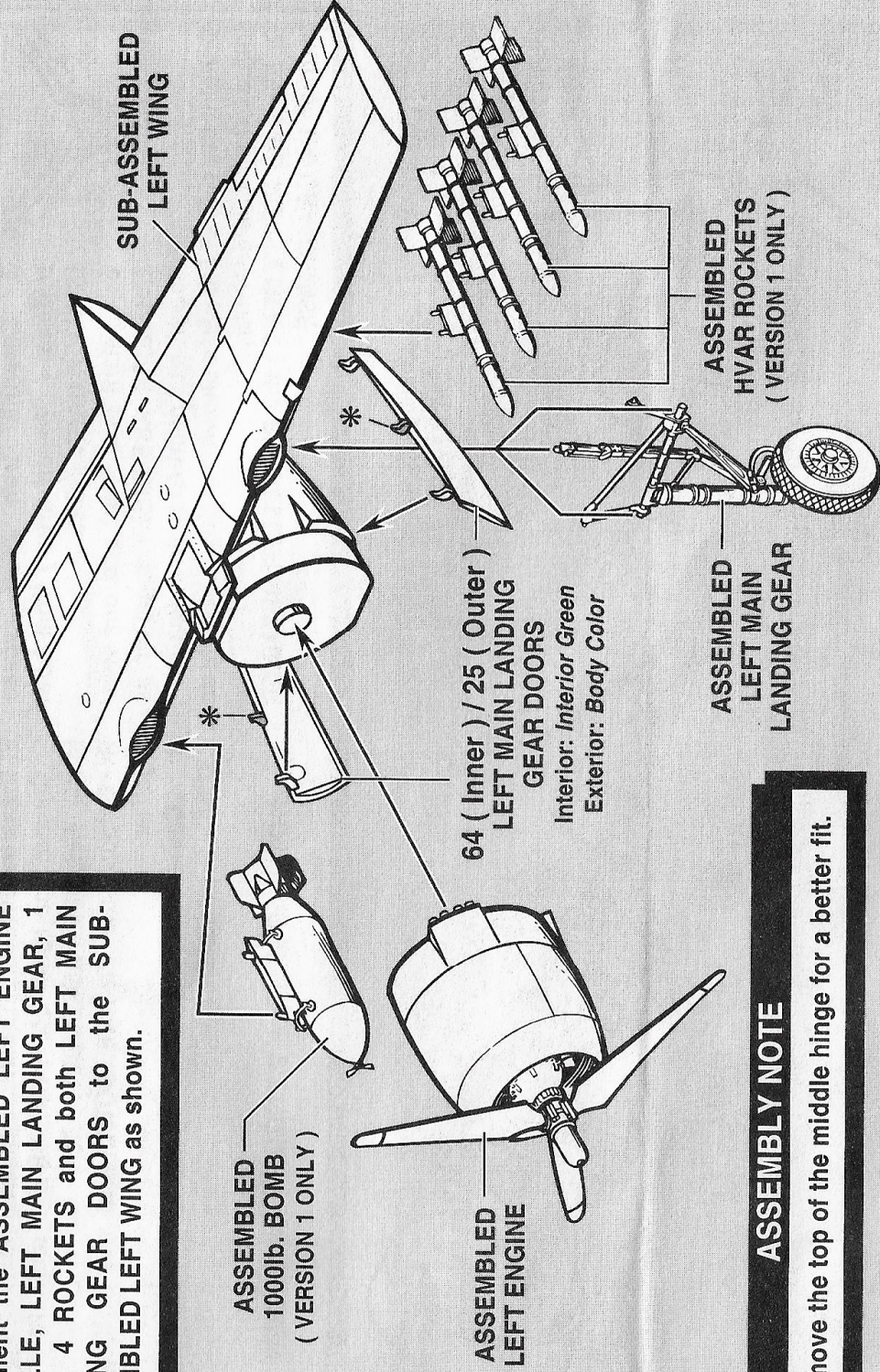

ASSEMBLY NOTE

*= Remove the top of the middle hinge for a better fit.

RIGHT WING FINAL ASSEMBLY

A: Cement the ASSEMBLED RIGHT ENGINE NACELLE, RIGHT MAIN LANDING GEAR, 1 BOMB, 4 ROCKETS and both RIGHT MAIN LANDING GEAR DOORS to the SUB-ASSEMBLED RIGHT WING as shown.

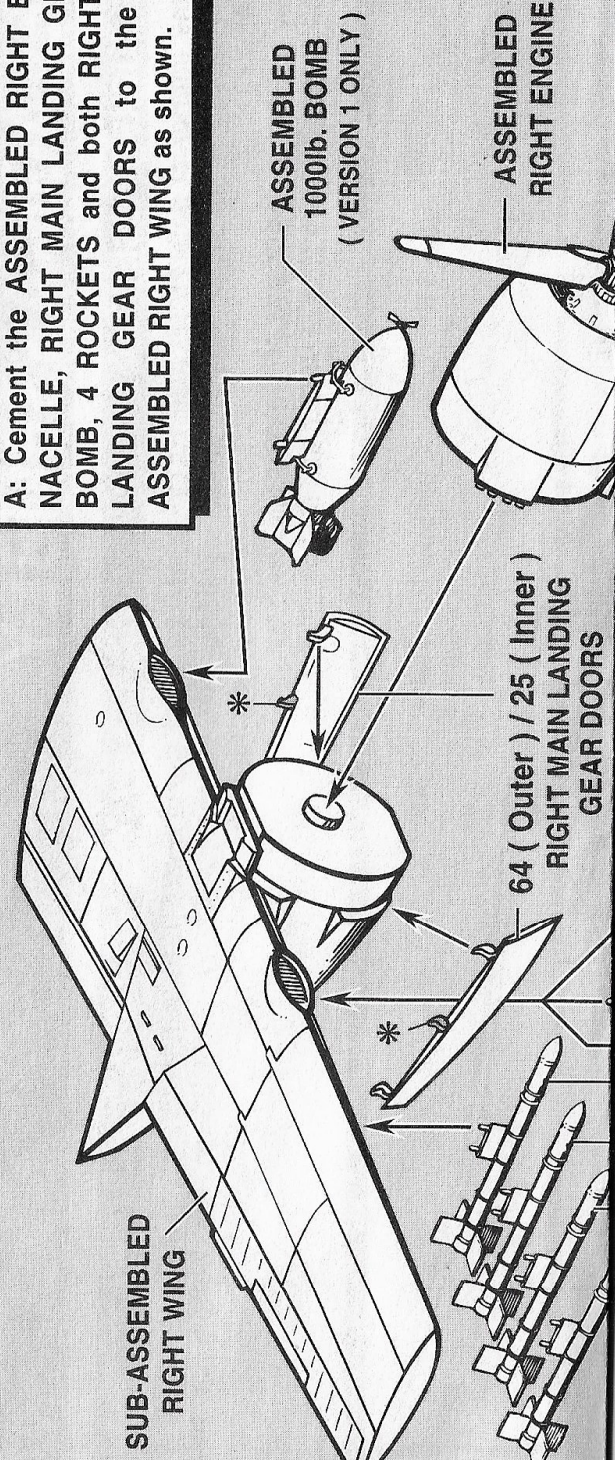

Interior: Interior Green
Exterior: Body Color

ASSEMBLED
RIGHT MAIN
LANDING GEAR

ASSEMBLED
HVAR ROCKETS
(VERSION 1 ONLY)

ASSEMBLY NOTE

*= Remove the top of the middle hinge for a better fit.

ASSEMBLED
LEFT HORIZONTAL
STABILIZER

60
AFT COVER
Body Color
(F7F - 2)

105
AFT CANOPY
(Clear)
(F7F - 2N)

102
CANOPY
(Clear)

101
WINDSHIELD
(Clear)

ASSEMBLED
LEFT WING

50
LADDER
Aluminum

ASSEMBLED
CENTERLINE
FUEL TANK
Cement to pylon
on the bottom of
the fuselage

ASSEMBLED
NOSE GEAR
Cement to 'bosses'
on each side of the gear
opening and to the hole
bottom of the cockpit floor

ASSEMBLED
FUSELAGE

44
NOSE GEAR DOOR
Interior: Interior Green
Exterior: Body Color

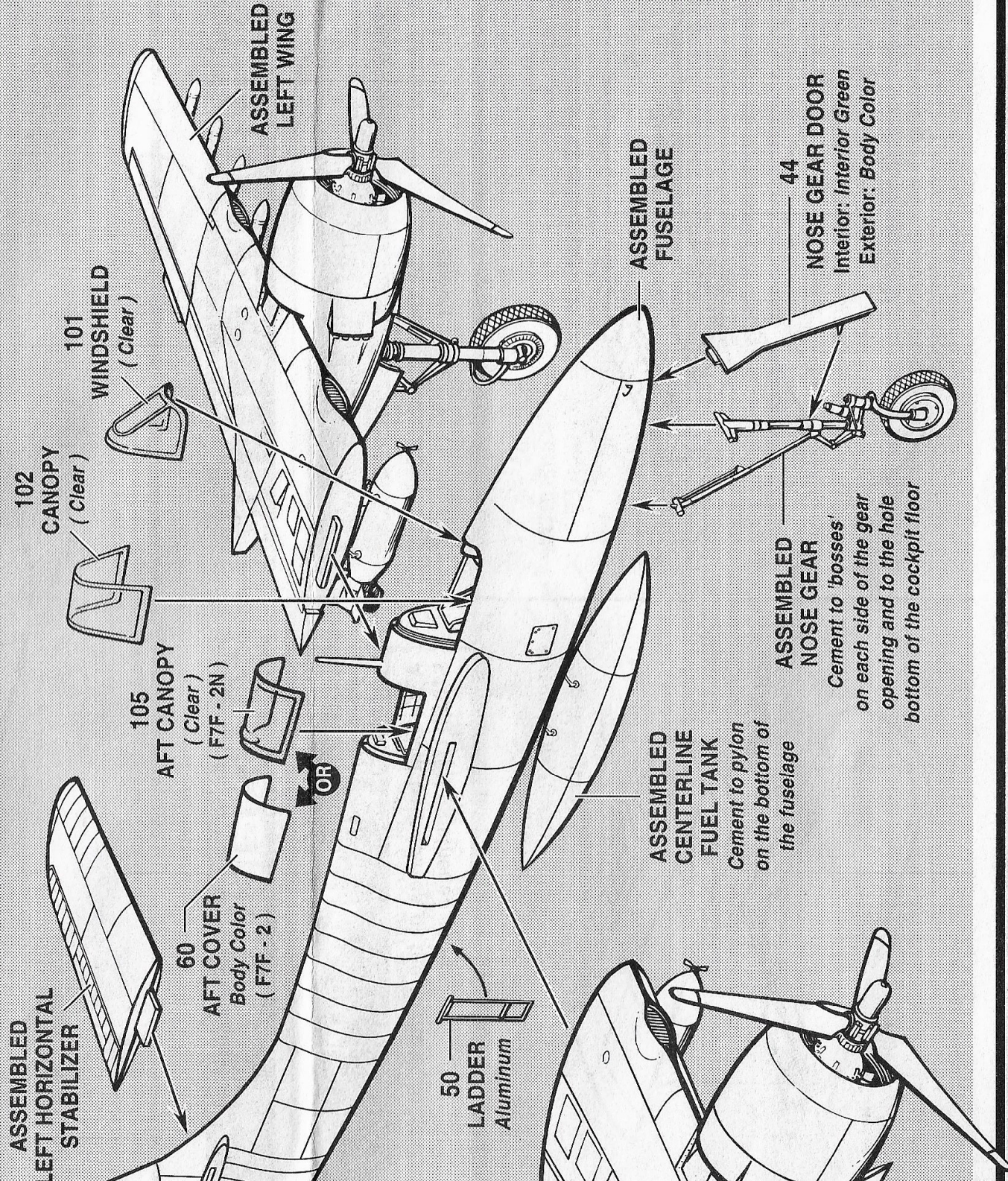
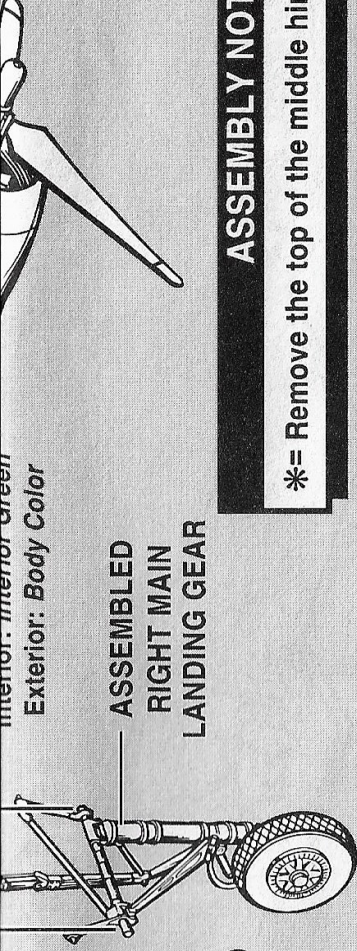

GRUMMAN F7F-2N

TIGERCAT

DECAL APPLICATION INSTRUCTIONS
VERSION 2

DECALS

- Choose the decals you want to put on your kit and use a scissors to cut it from the decal sheet.
- Dip the decal in a cup of lukewarm water for about fifteen seconds to loosen the decal from the backing paper.
- Place the decal in position and slide the decal off the backing paper and onto the model.
- Use a soft, damp cloth to gently rub away any water bubbles under the decal.

STOCK No. 8844

Form No. 099 - 1295

SHEET 2 OF 2

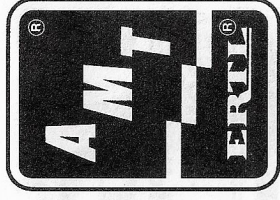

F7F-2N TIGERCAT (BuNo 80330)
as seen at the Naval Air Test
Center in 1948.

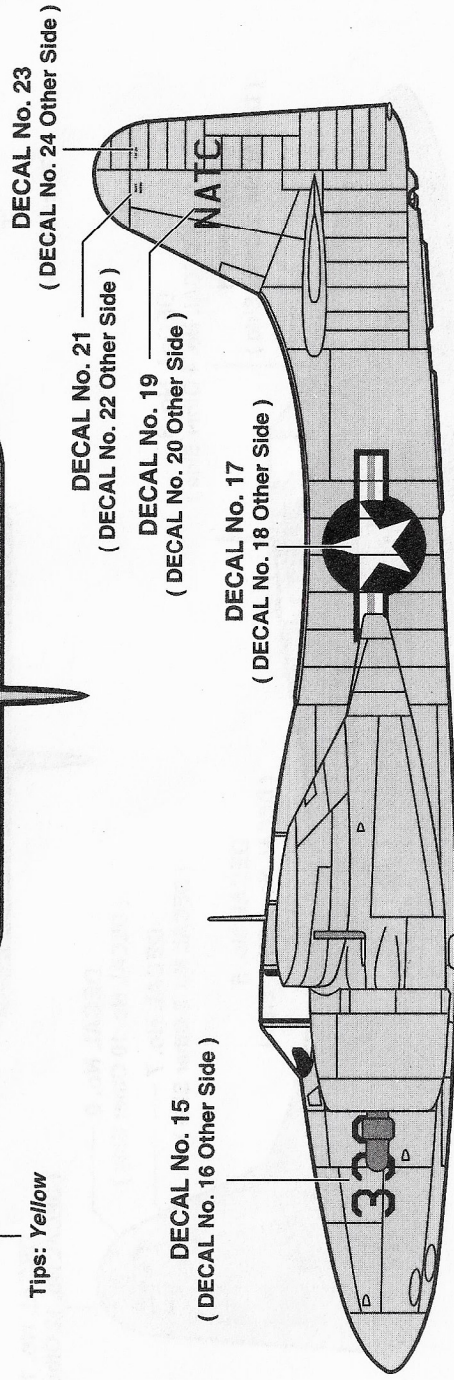
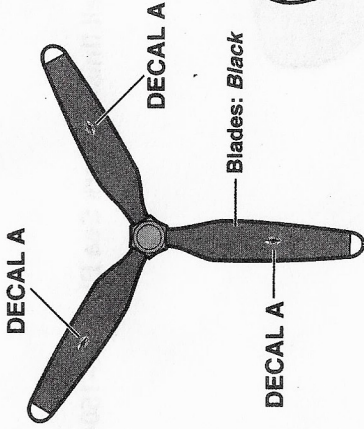
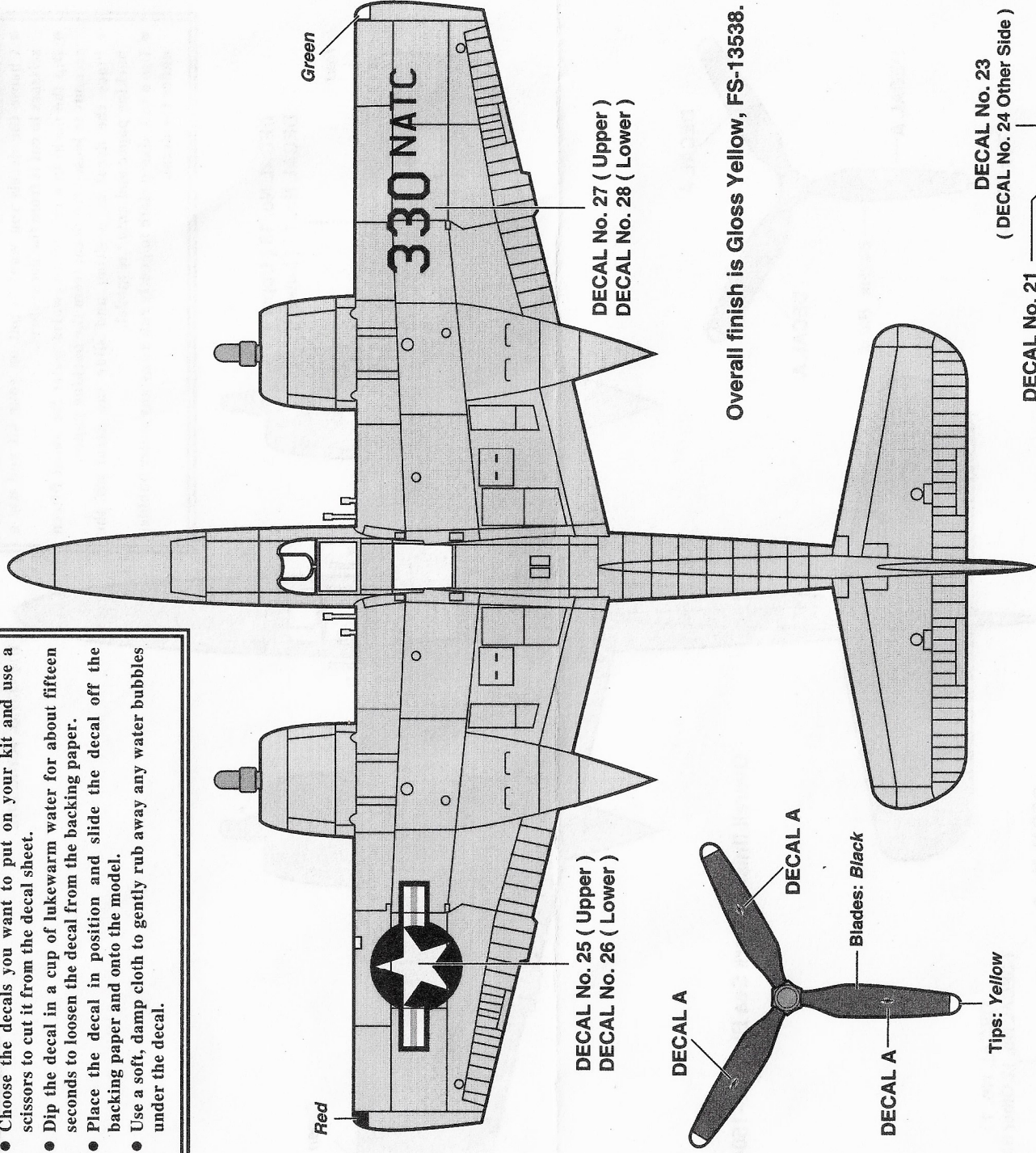

GRUMMAN F7F-2N TIGERCAT

DECAL APPLICATION INSTRUCTIONS VERSION 1

STOCK No. 8844
Form No. 099 - 1295
SHEET 2 OF 2

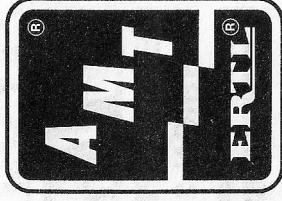

DECALS

- Choose the decals you want to put on your kit and use a scissors to cut it from the decal sheet.
- Dip the decal in a cup of lukewarm water for about fifteen seconds to loosen the decal from the backing paper.
- Place the decal in position and slide the decal off the backing paper and onto the model.
- Use a soft, damp cloth to gently rub away any water bubbles under the decal.

F7F-2N TIGERCAT (BuNo 80323)
from VF(N)-52 as seen during carrier
qualifications on April 8, 1945 aboard
the U.S.S. Antietam.

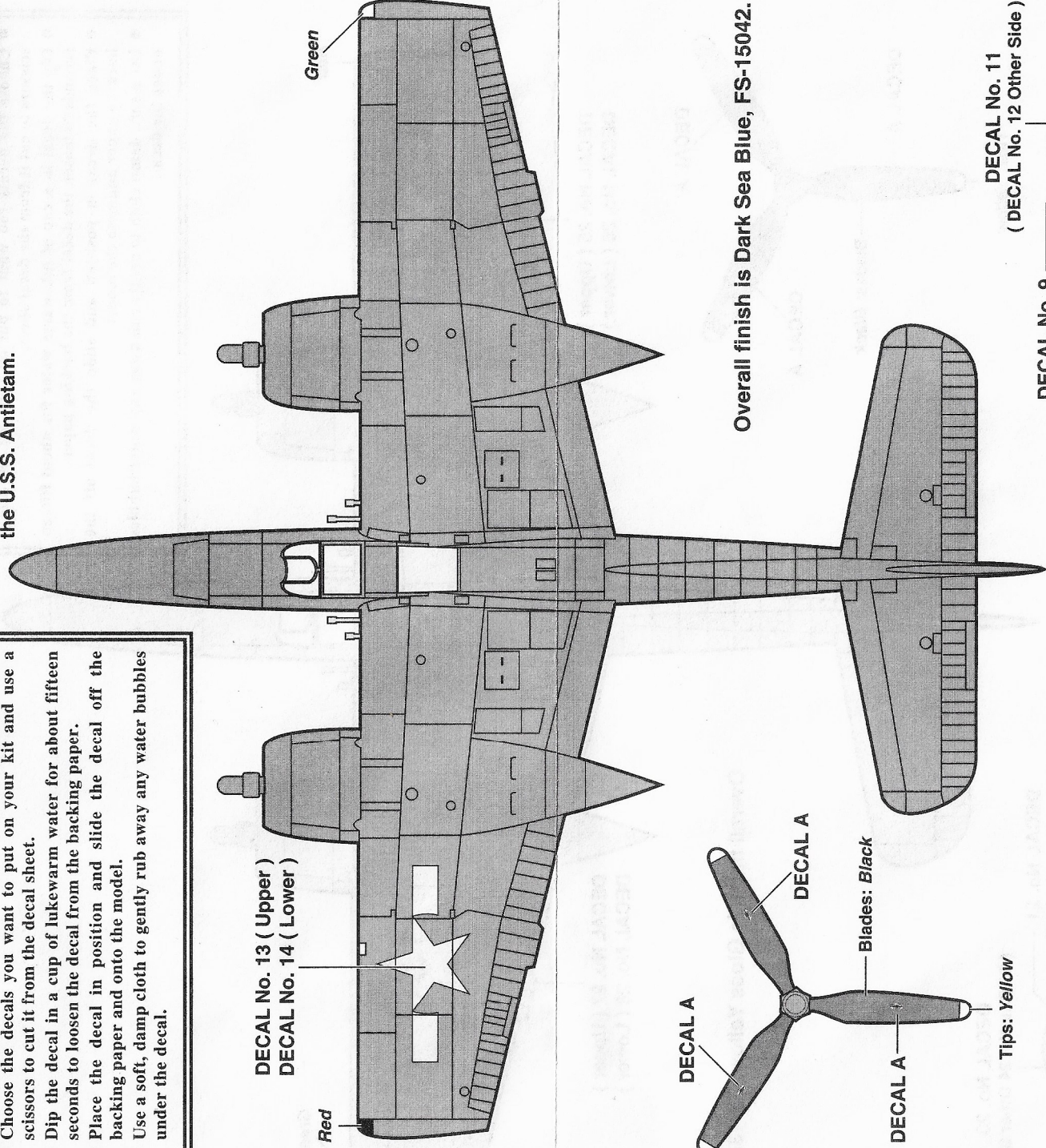

Overall finish is Dark Sea Blue, FS-15042.

