

## 1:48 SCALE PLASTIC KIT



### intro

#### Spanish Civil War and Legion Condor

The Spanish Civil War was fought from 1936 to 1939 between the Republicans, who were loyal to the democratic, left-leaning Second Spanish Republic, led by the government of Manuel Azaña, and the Nationalists, led by General Francisco Franco. The Nationalists won, and Franco then ruled Spain for the next 36 years, from April 1939 until his death in November 1975.

The Nationalist opposition was led by a group of officers of the Spanish Republican Armed Forces, originally under the leadership of General José Sanjurjo. However, Sanjurjo died in an aircraft accident, and Franco emerged as the leader.

The conflict developed into an international affair shortly after its beginning. Most countries declared their neutrality, but some others engaged in the conflict for political reasons. One of the first countries involved was Germany, sympathizing with the Nationalists. After some rather sporadic activities, Germany created the Legion Condor, an expeditionary unit consisting of both ground and air forces. The air force assets of Legion Condor consisted of K/88 bombing unit, J/88 fighter unit, A/88 tasked with observation duties, AS/88 naval observation unit, plus VB/88 and VJ/88 training units.

The Luftwaffe sent several aircraft types to Spain, with Ju 52s first, followed by He 51s. The first six He 51s were sent on board the Usaramo together with German pilots on the 6th of August, 1936. Initially, the German pilots conducted training of selected Spanish pilots only, and two of them recorded their first aerial victories on He 51s on the 18th of August, 1936. Shortly afterwards, the German pilots also started combat flying and although more aerial victories were achieved, with the rising strength of the opposition air forces, it became obvious that the plane was already obsolete and vulnerable as an interceptor. It did not stop deliveries of the He 51s in its B-1 and C-1 versions, and the type was used mainly for ground attack missions. The true interceptor appeared in the Spanish skies in mid 1937, when the first production variants of the Bf 109 appeared. The newest and most advanced fighter of the time then ruled the Spanish theatre till the end of the conflict with great success. Some 131 Bf 109s were sent (some sources citing up to 136), including the V3, V4 and V5 prototypes. The B, C and D marks followed, with supplies peaking with Bf 109E-1s and E-3s.

#### Early Messerschmitt Bf 109s

One of the most famous fighter aircraft of all time was conceived by Willy Messerschmitt, a designer who had never before designed a military aircraft, choosing to concentrate for whatever reasons on sport and civilian transport types. Taking this into consideration, winning the competition for the new standard Luftwaffe fighter looked like a small miracle. But Messerschmitt was well aware of what he was doing, and he adopted the best of his design philosophies to create a compact and lightweight air plane with a wing of rather small area to achieve high maximum speeds. At the end of the day, it was the higher speed along with some other aspects, such as the ease of construction of the Bf 109's trapezoid wing in comparison to the more complex shape of its main and final opponent, the He 112, that swung the competition in favour of the Messerschmitt design.

The first prototype Bf 109 V1 took off for the very first time on May 28th, 1935, but only with a provisional installation of a British Rolls Royce Kestrel engine, as the intended Jumo 210D unit was not available at the time. But subsequent prototypes and production marks A, B and C were already powered by the Jumo engine only to find out that more power was needed, which led to the adoption of the DB 601 engine for the Bf 109E version.

The birth of the Bf 109 essentially coincided with the start of the Spanish Civil War, and because of the participation of the Legion Condor, it was quite logical to take advantage of the situation and prove the new fighter in actual combat. During September and November 1936, the V3 and V4 prototypes were sent to Spain, followed by the first Bf 109B-1 in December. In a short period of time, the new C and D versions were supplied and even the final interwar version, the Bf 109E-3 tasted combat over the Iberian Peninsula prior to Second World War involvement.

#### Heinkel He 51B

The first German fighter airplane to record an aerial victory after the end of the Great War was the Heinkel He 51. It was a design of the Heinkel company, already producing numerous successful aircraft types, but lagging behind Arado when it came to design of fighter aircraft. The Heinkel H.D. 43 prototype was rejected in comparison trials with the Arado Ar 65. As a result, and in view of the fact the resurrection of the German air force was nearing promising huge contracts, Ernst Heinkel hired Siegfried and Walter Günther, brothers who were young and promising designers, to create a new Heinkel fighter. They began with cooperation on the He 49 design and then upgraded it to develop the He 51. It was quite an elegant air plane thanks to the aesthetic touch of Walther Günther, but also quite big and underpowered for a fighter. Moreover, the new plane was not as forgiving of pilot mistakes as was the Arado Ar 65E, was also less maneuverable and suffered from a rather poor view from the cockpit during take off and landing. Despite these issues, the He 51 became one of the symbols of the newborn Luftwaffe, once the Nazi party took control of Germany. Under the promotional Reklame-Staffel wings, the He 51 demonstrated the rising power of German military force at numerous occasions. The birth of the new Luftwaffe was officially announced on March 1st, 1935, and shortly after that, the new He 51B version was introduced. It differed from He 51A in details, the only noticeable difference being the installation of the external fuel tank under the fuselage. For maritime use with Küstenjagdgeschwader 136 tasked with coastline patrolling, the float version He 51B-2 was also introduced.

At the dawn of the Spanish Civil War, the He 51 was already obsolete, and after an initial period of German involvement, serving in the interceptor role, the plane was tasked with air-to-ground missions. For this role, three bomb racks for small 10 kg bombs were installed, this version being designated as the He 51C-1. The He 51 was still in service with the Luftwaffe at the beginning of the Second World War, but only as a trainer. On the other hand, the Spanish Air Force used surviving aircraft until 1952.



Carefully read instruction sheet before assembling. When you use glue or paint, do not use near open flame and use in well ventilated room. Keep out of reach of small children. Children must not be allowed to suck any part, or pull vinyl bag over the head.



Před započítím stavby si pečlivě prostudujte stavební návod. Při používání barev a lepidel pracujte v dobře větrané místnosti. Lepidla ani barvy nepoužívejte v blízkosti otevřeného ohně. Model není určen malým dětem, mohlo by dojít k požití drobných dílů.

## INSTRUCTION SIGNS \* INSTR. SYMBOL \* INSTRUKTION SINNBILDEN \* SYMBOLES \* 記号の説明



OPTIONAL  
VOLBA



BEND  
OHNOUT



OPEN HOLE  
VYVRTAT OTVOR



SYMMETRICAL ASSEMBLY  
SYMETRICKÁ MONTÁŽ



REMOVE  
ODŘÍZNOUT



REVERSE SIDE  
OTOČIT



APPLY EDUARD MASK  
AND PAINT  
POUŽÍT EDUARD MASK  
NABARVIT

## PARTS



## DÍLY



## TEILE



## PIÈCES



## 部品

## PLASTIC PARTS

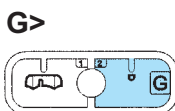
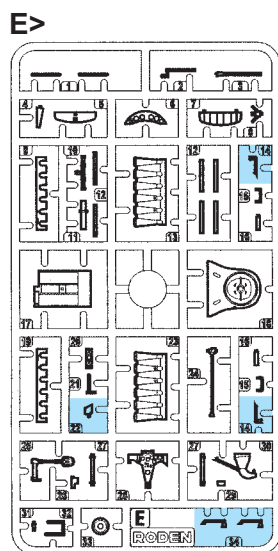
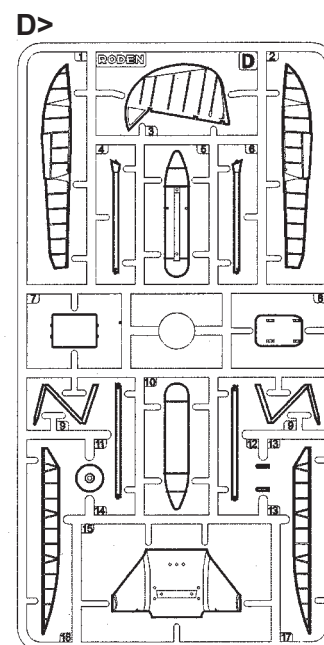
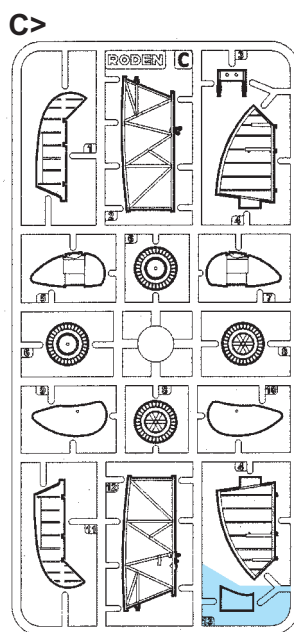
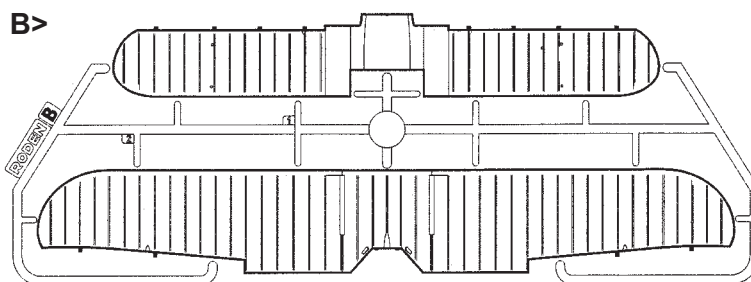
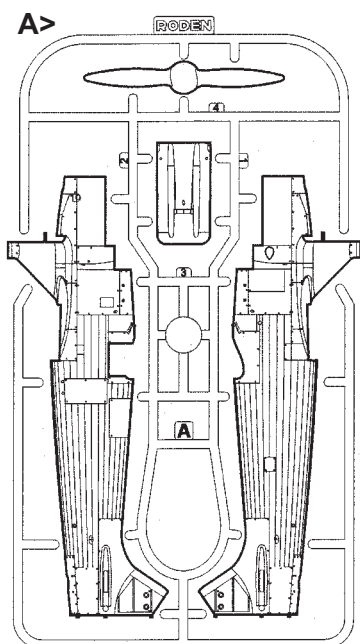

## PE - PHOTO ETCHED DETAIL PARTS

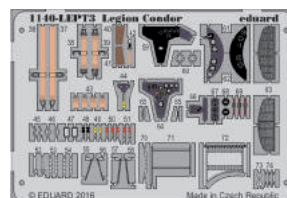
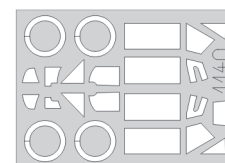
eduard  
MASK

-Parts not for use. -Teile werden nicht verwendet. -Pièces à ne pas utiliser. -Tyto díly nepoužívejte při stavbě. - 使用しない部品

## COLOURS



## BARVY



## FARBEN



## PEINTURE



## 色

GSI Creos (GUNZE)		
AQUEOUS	Mr.COLOR	
H 8	C8	SILVER
H 11	C62	FLAT WHITE
H 12	C33	FLAT BLACK
H 33	C81	RUSSET
H 37	C43	WOOD BROWN
H47	C41	RED BROWN
H 67	C115	LIGHT BLUE
		RLM 65

AQUEOUS	Mr.COLOR		
H 70	C60	GRAY	RLM 02
H 77	C137	TIRE BLACK	
H 303	C303	GREEN	RLM 62
H 338	C308	GRAY	RLM 63
H 406	C406	BROWN	RLM 61
Mr.METAL COLOR			
	MC214	DARK IRON	

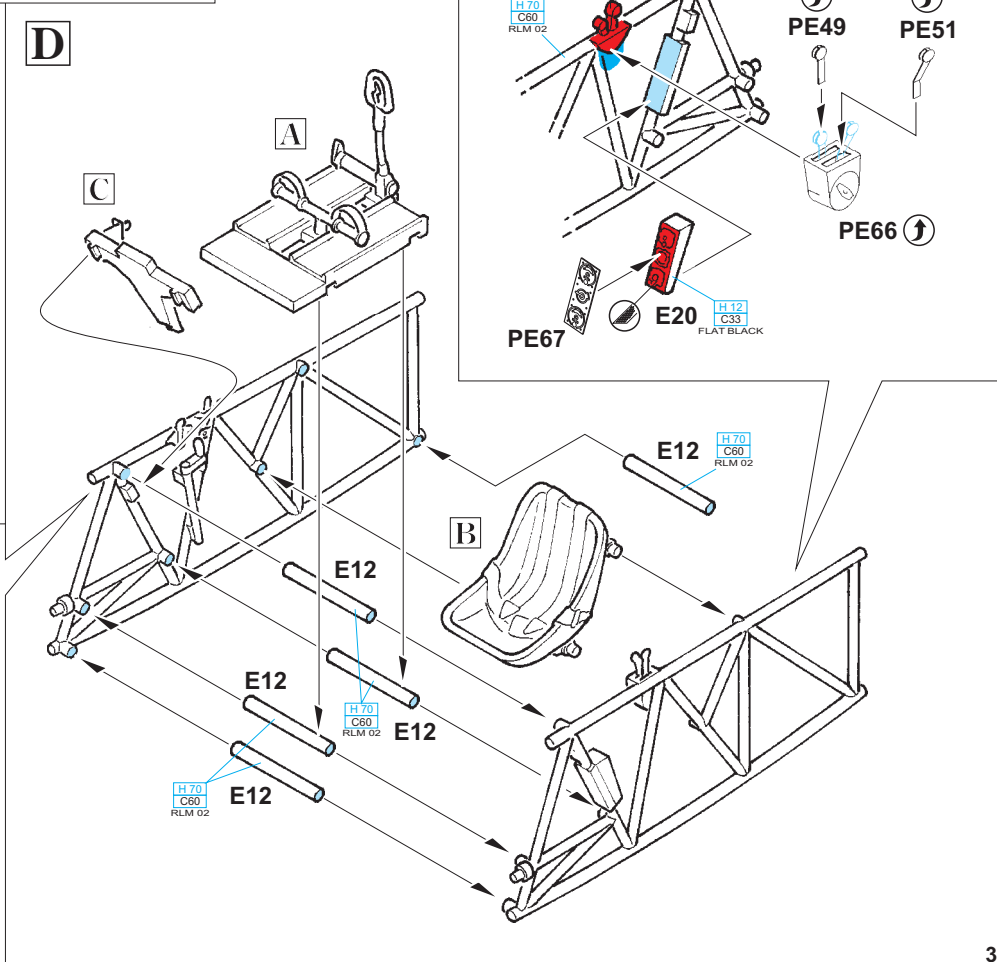
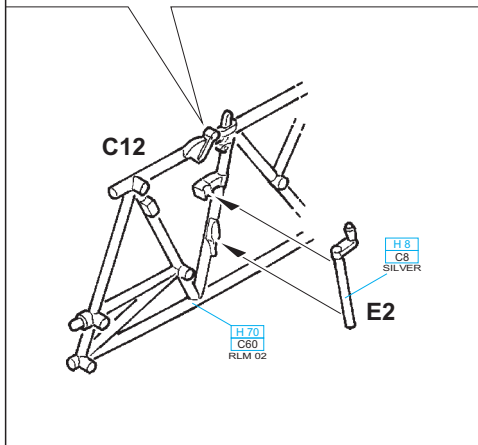
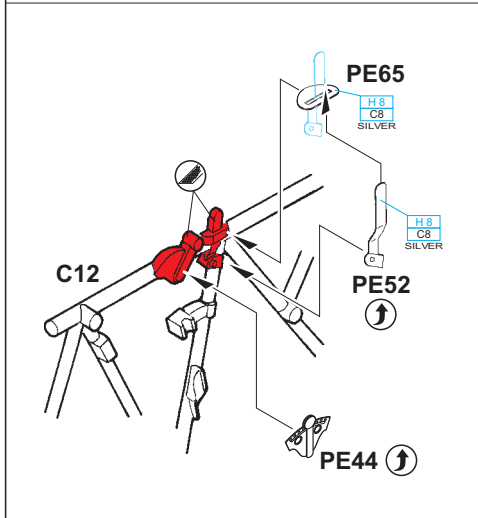
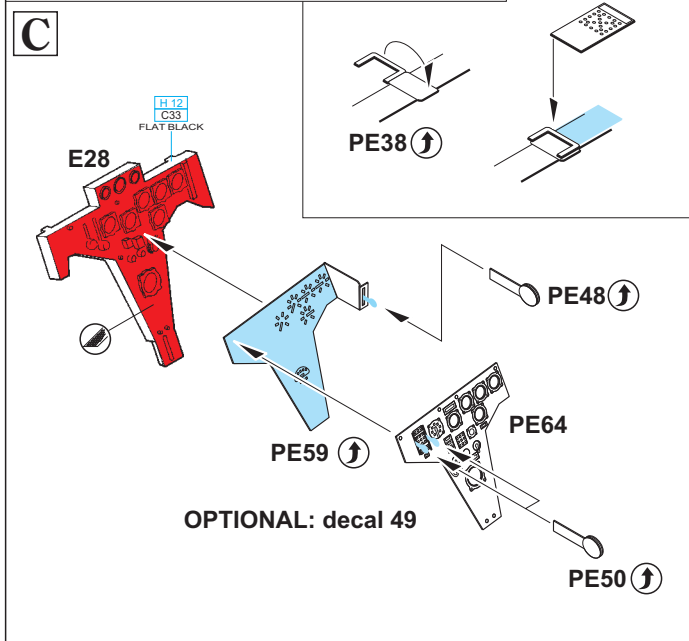
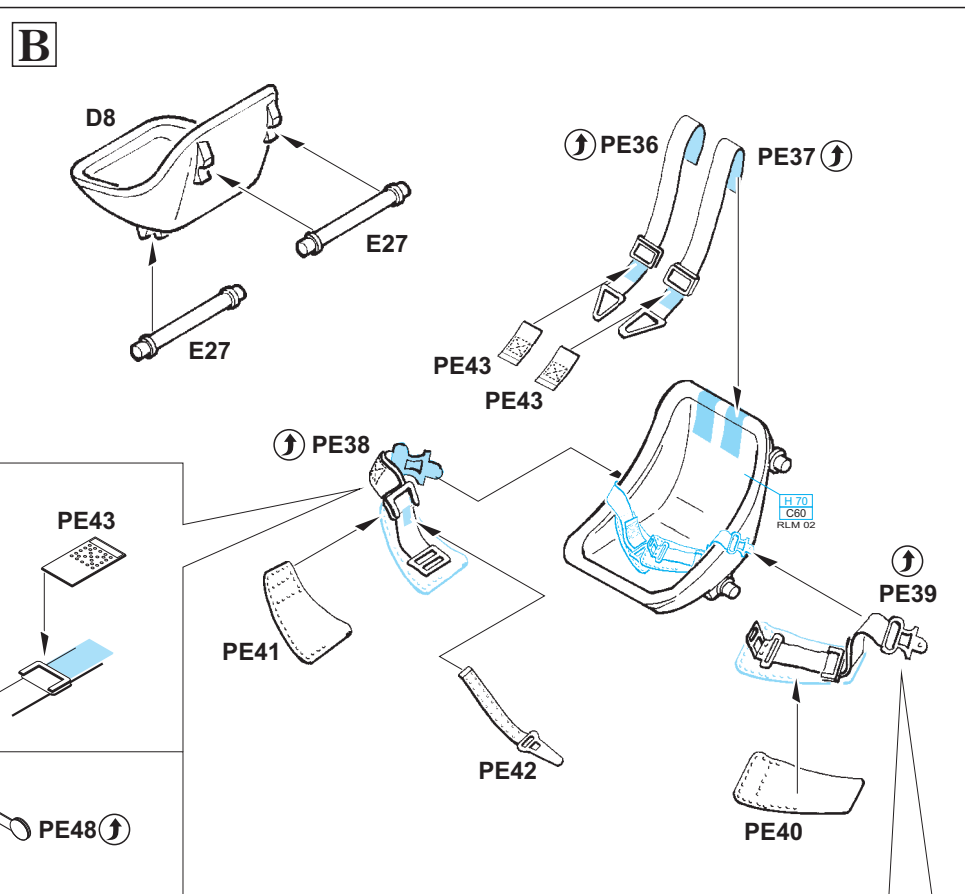
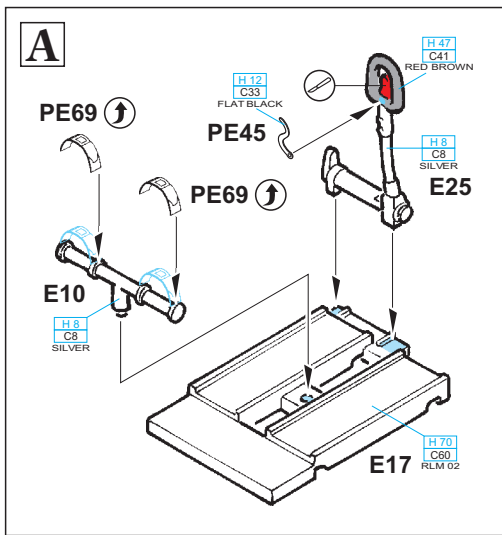

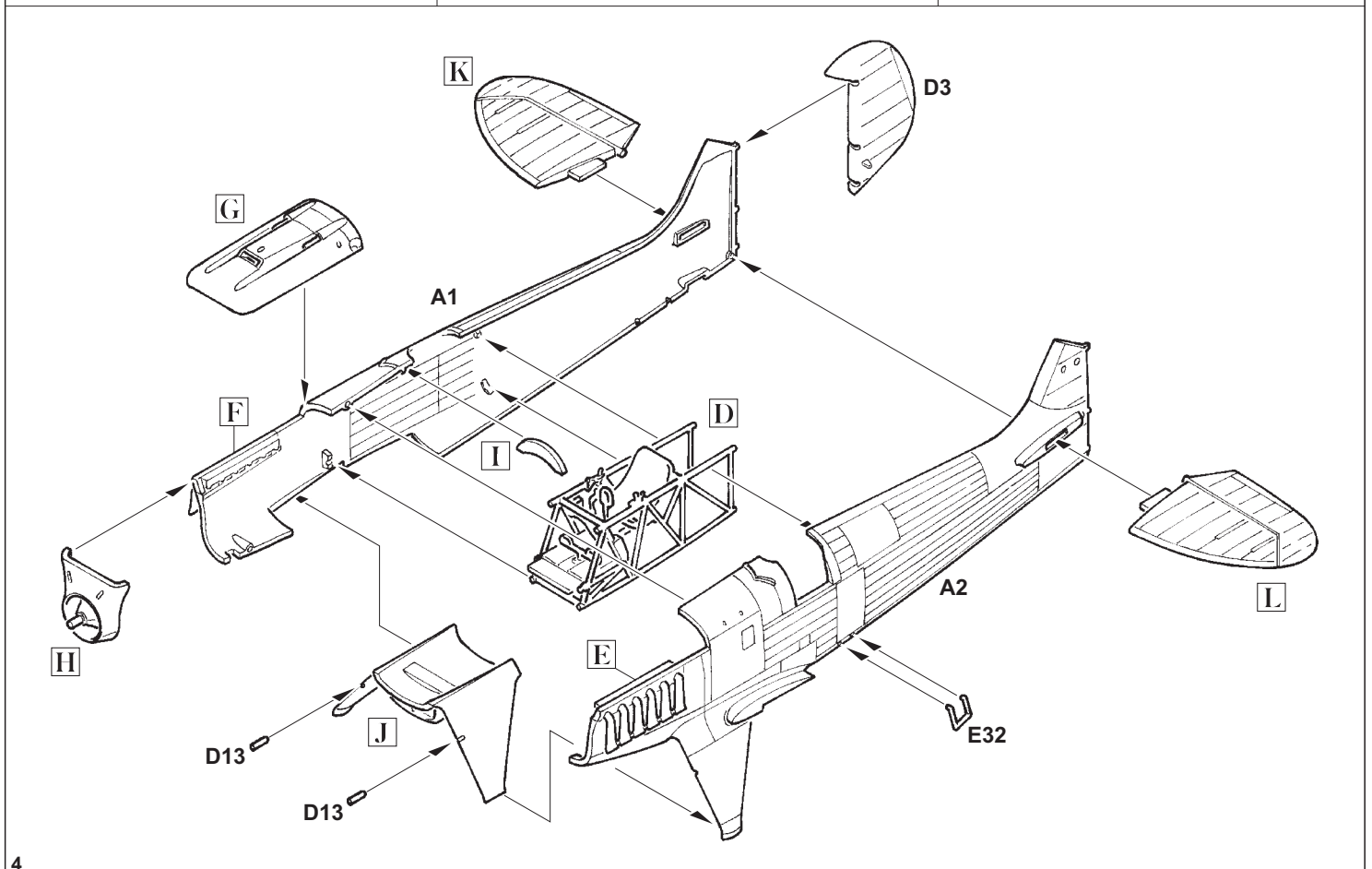
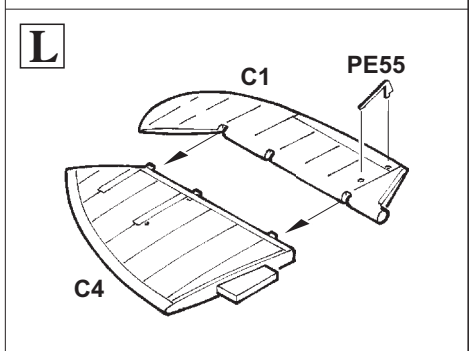
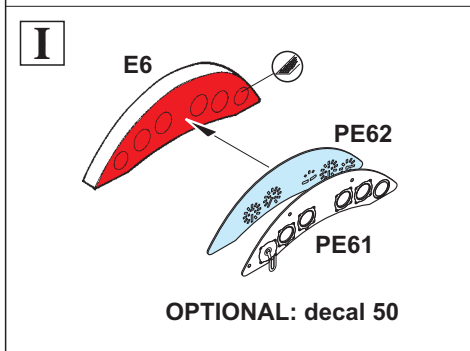
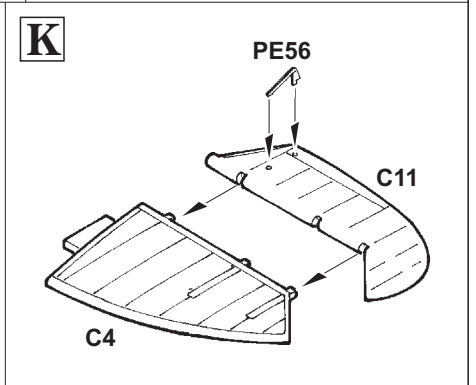
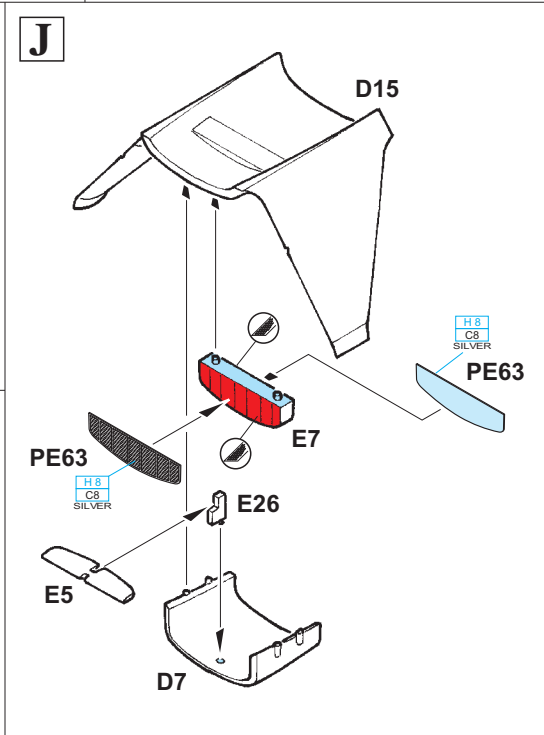
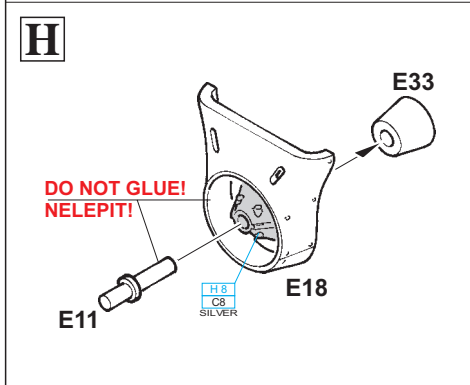
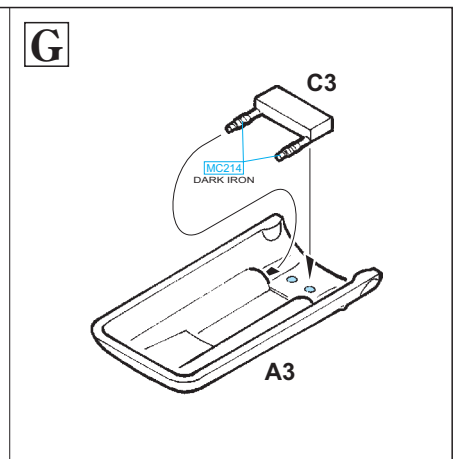
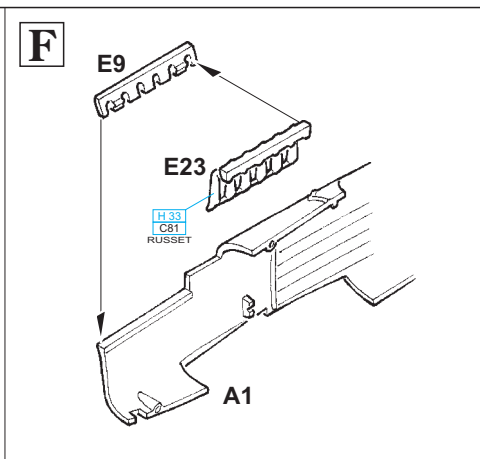
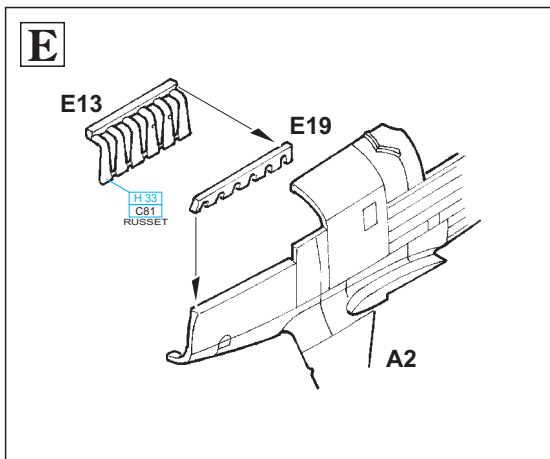



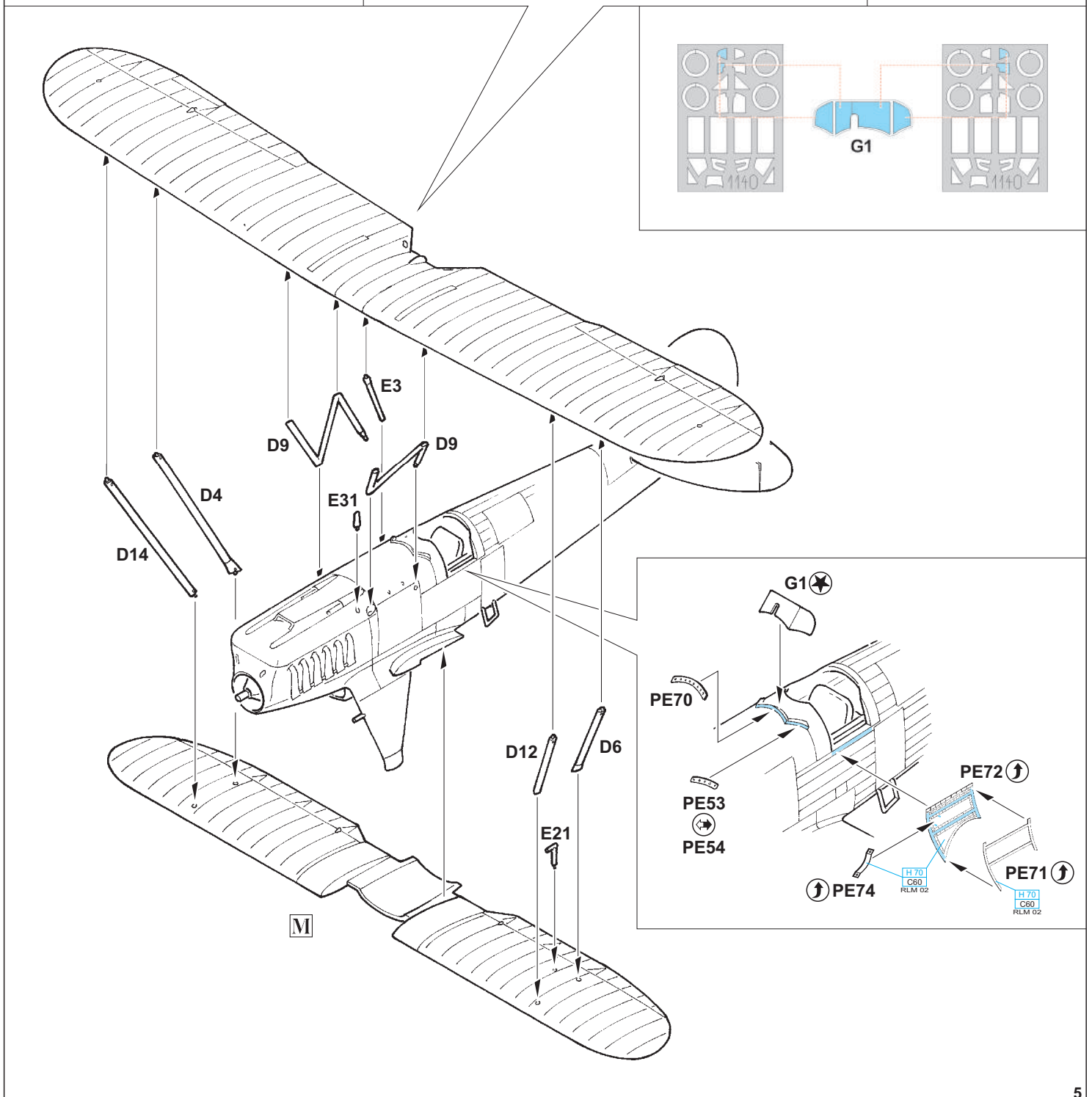
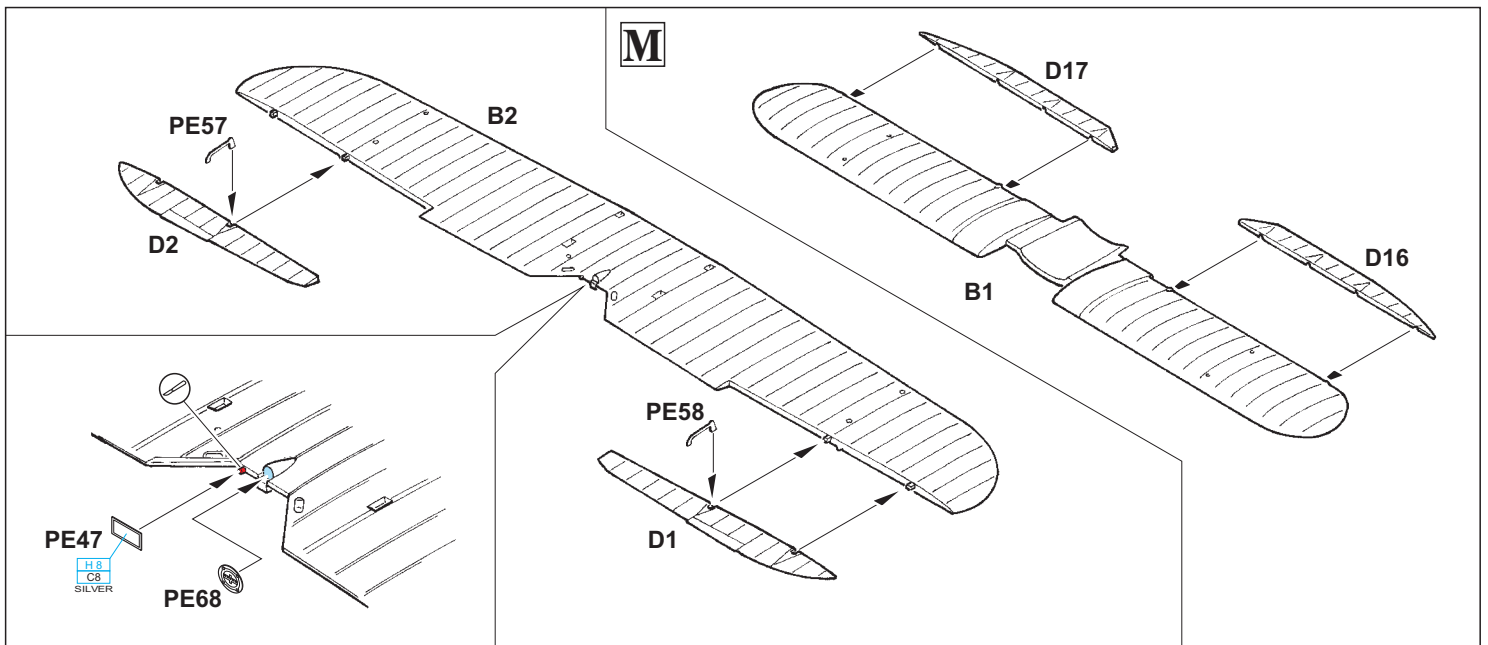

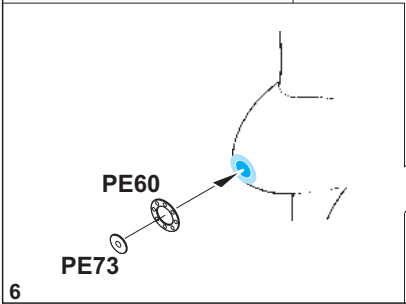
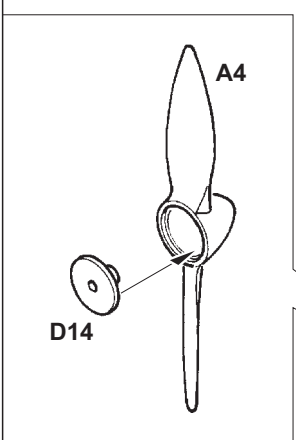
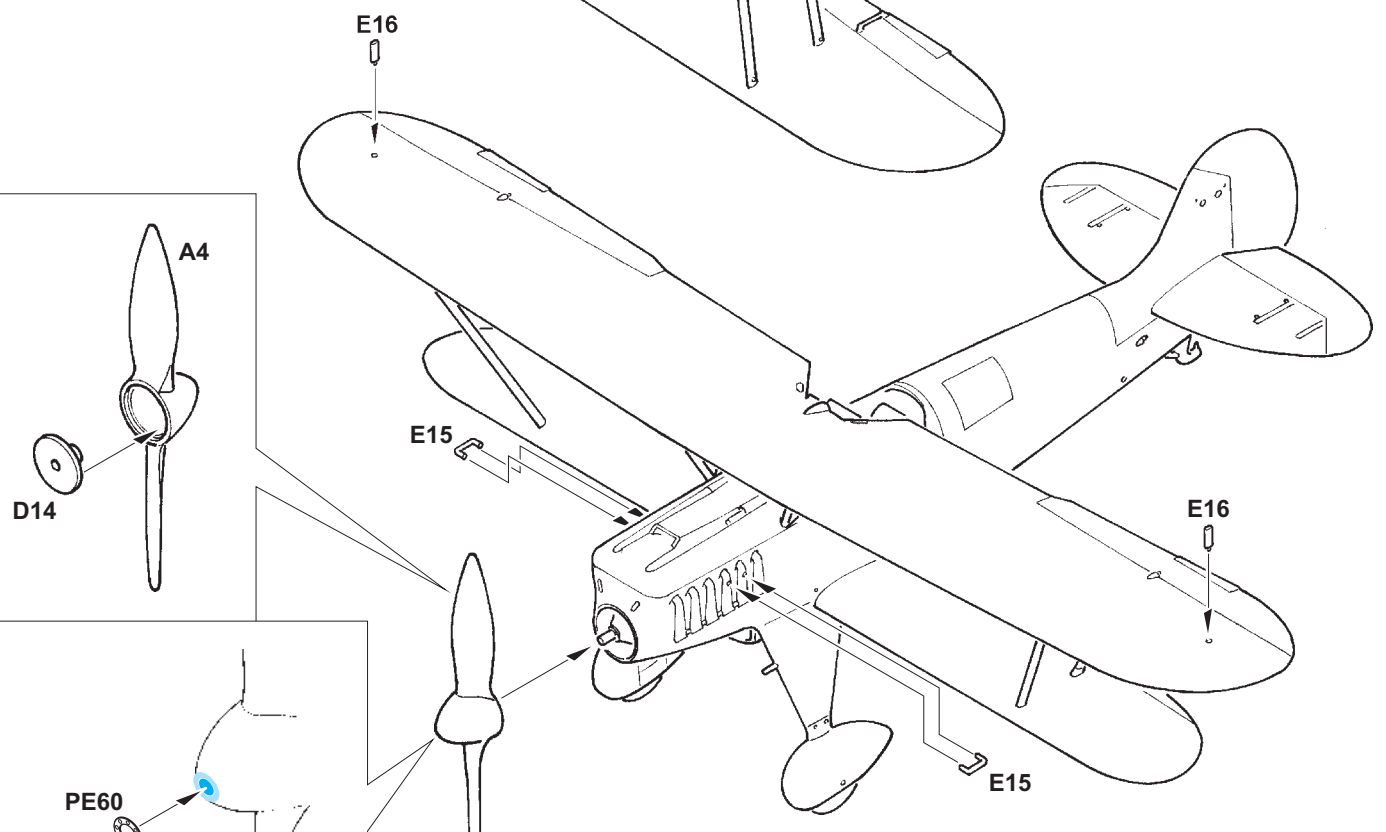
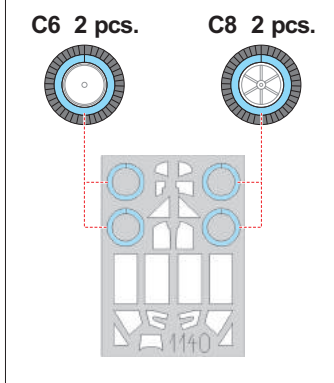
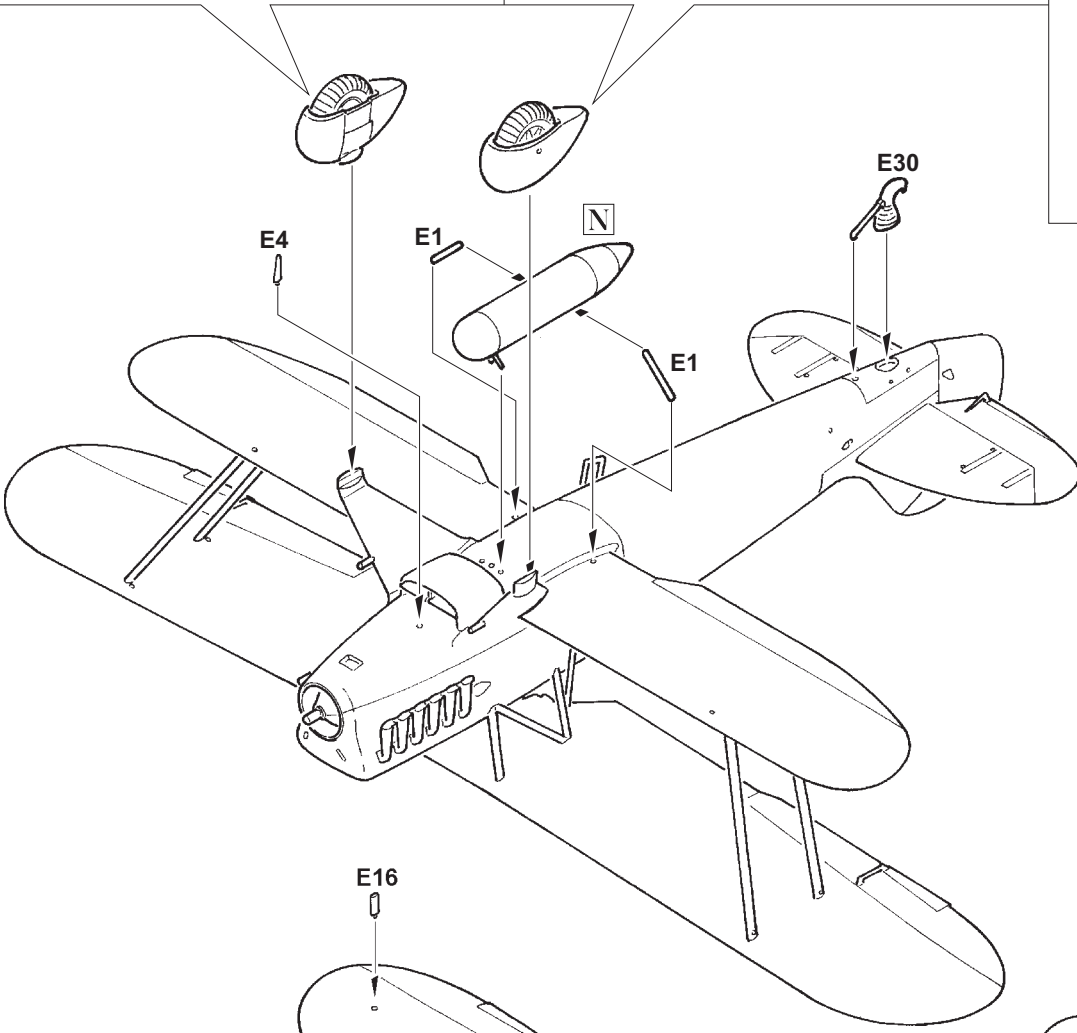
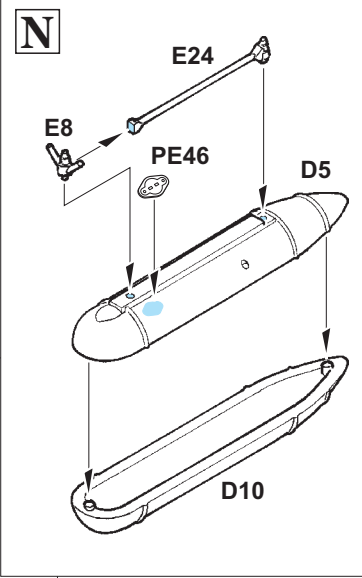
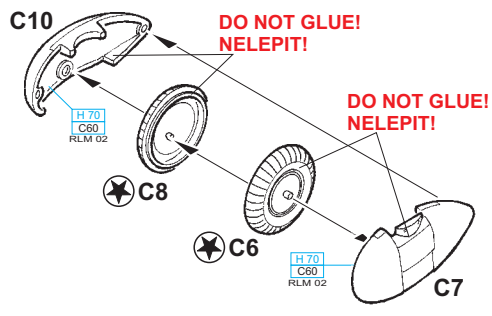
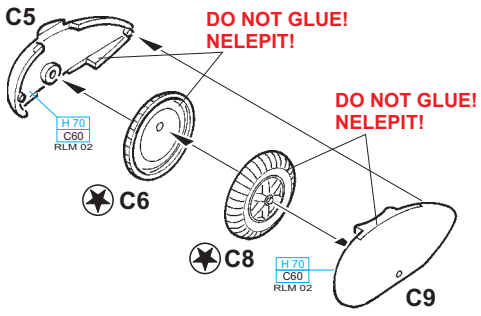

ATTENTION



UPOZORNĚNÍ



ACHTUNG



ATTENTION



注意



Carefully read instruction sheet before assembling. When you use glue or paint, do not use near open flame and use in well ventilated room. Keep out of reach of small children. Children must not be allowed to suck any part, or pull vinyl bag over the head.



Před započítím stavby si pečlivě prostudujte stavební návod. Při používání barev a lepidel pracujte v dobře větrané místnosti. Lepidla ani barvy nepoužívejte v blízkosti otevřeného ohně. Model není určen malým dětem, mohlo by dojít k požití drobných dílů.

INSTRUCTION SIGNS \* INSTR. SYMBOLS \* INSTRUKTION SINNBILDEN \* SYMBOLES \* 記号の説明

OPTIONAL  
VOLBABEND  
OHNOUTOPEN HOLE  
VYVRTAT OTVORSYMMETRICAL ASSEMBLY  
SYMETRICKÁ MONTÁŽREMOVE  
ODŘÍZNOUTREVERSE SIDE  
OTOČITAPPLY EDUARD MASK  
AND PAINT  
POUŽÍT EDUARD MASK  
NABARVIT

PARTS



DÍLY



TEILE



PIÈCES



部品

## PLASTIC PARTS

A&gt;

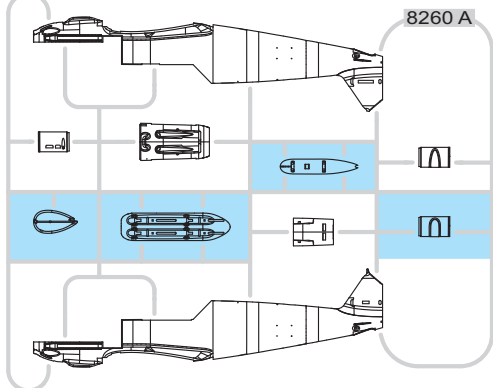

B&gt;

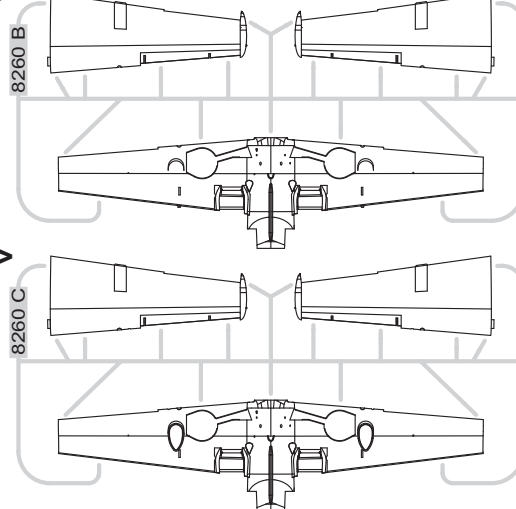

F&gt;

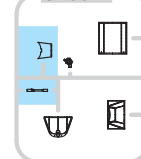

D&gt;

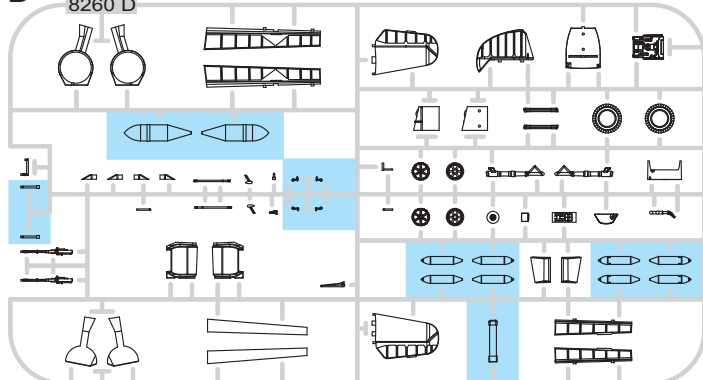

E&gt;

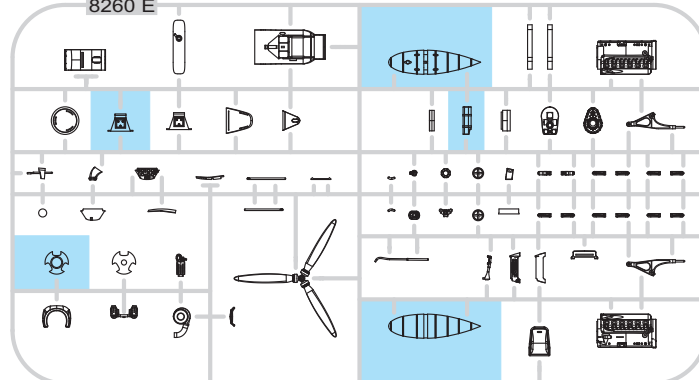

## PE - PHOTO ETCHED DETAIL PARTS

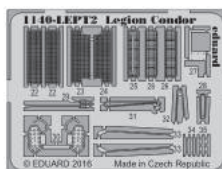
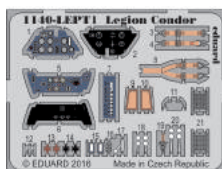

-Parts not for use. -Teile werden nicht verwendet. -Pièces à ne pas utiliser. -Tyto díly nepoužívejte při stavbě. - 使用しない部品

COLOURS



BARVY



FARBEN



PEINTURE



色

GSI Creos (GUNZE)			
AQUEOUS	Mr.COLOR		
H2	C2	BLACK	
H3	C3	RED	
H11	C62	FLAT WHITE	
H12	C33	FLAT BLACK	
H33	C81	RUSSET	
H47	C41	RED BROWN	
H65	C18	BLACK GREEN	RLM 70
H67	C115	LIGHT BLUE	RLM 65

AQUEOUS	Mr.COLOR		
H70	C60	GRAY	RLM 02
H77	C137	TIRE BLACK	
H303	C303	GREEN	
H308	C308	GRAY	
H413	C113	YELLOW	RLM 04
Mr.METAL COLOR			
	MC213	STEEL	
	MC214	DARK IRON	
	MC218	ALUMINIUM	

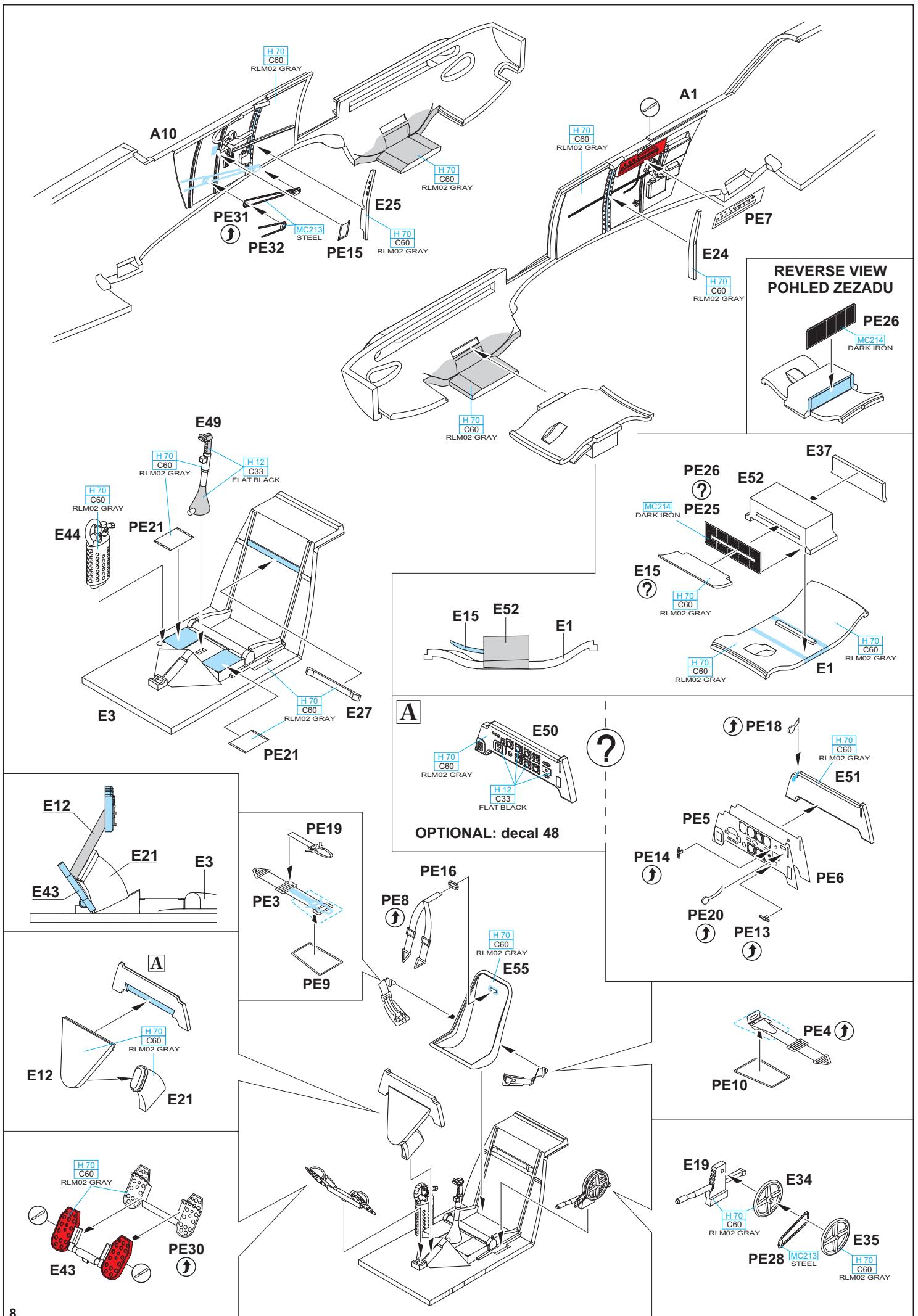



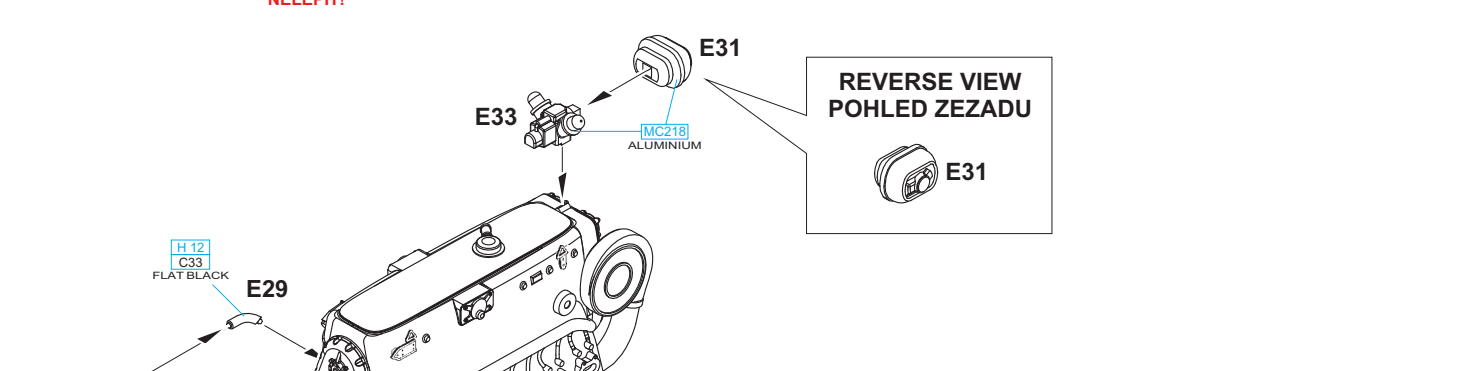
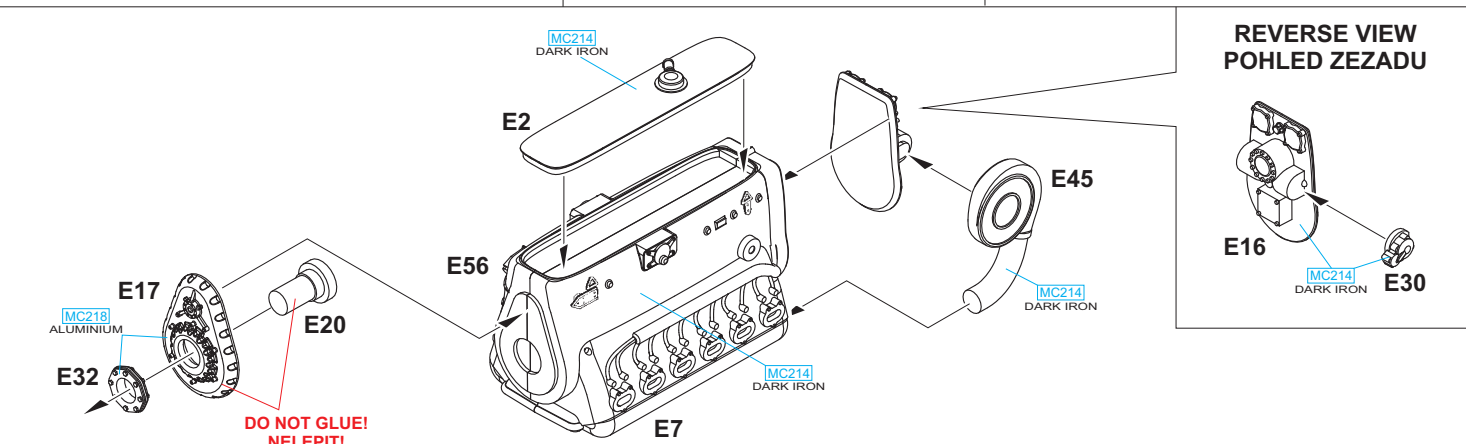
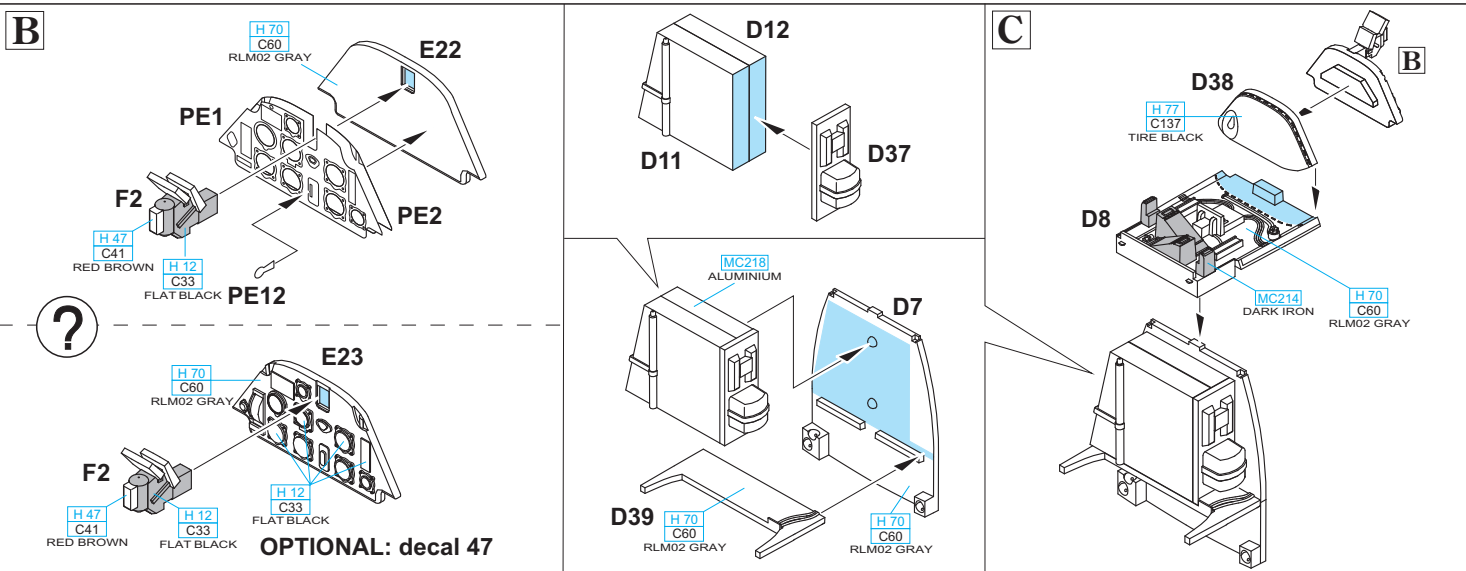

**E48 - FIRST**    **E48 - PRVNÍ**  
**E18 - NEXT**    **E18 - DRUHÝ**

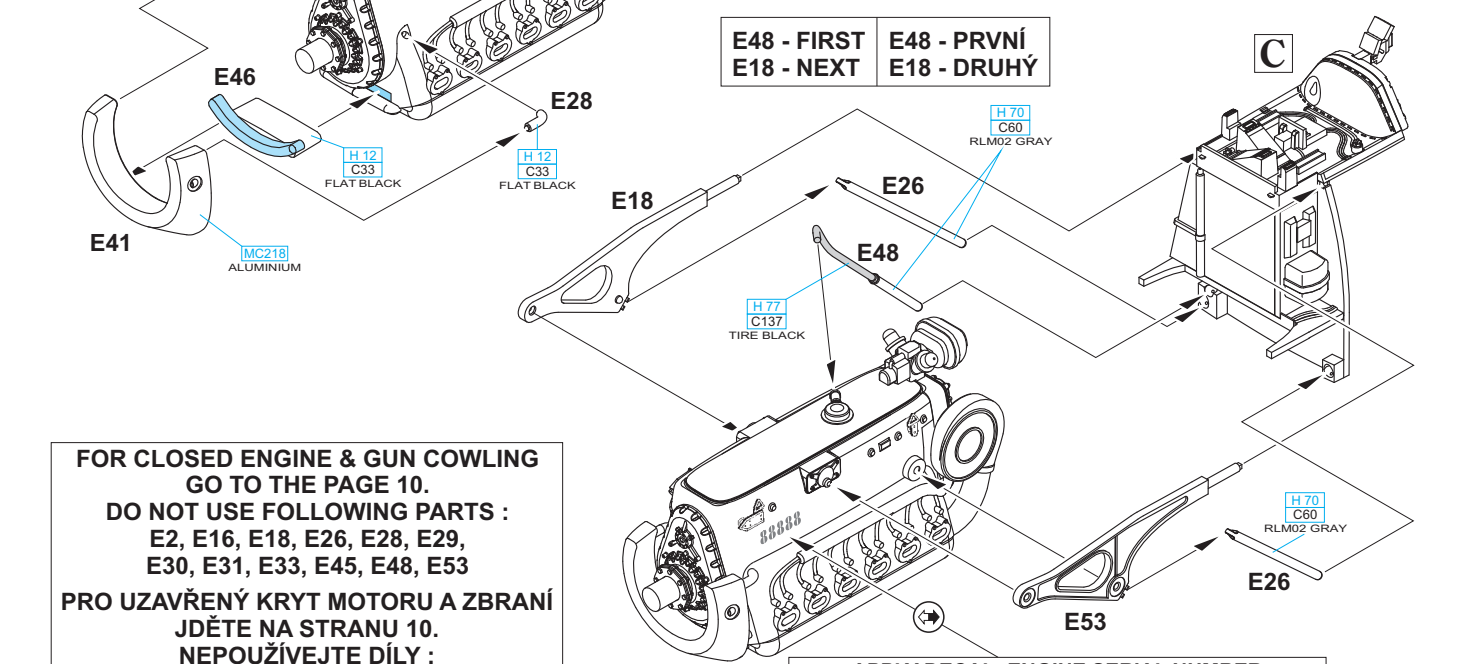

**FOR CLOSED ENGINE & GUN COWLING  
GO TO THE PAGE 10.  
DO NOT USE FOLLOWING PARTS :**  
E2, E16, E18, E26, E28, E29,  
E30, E31, E33, E45, E48, E53

**PRO UZAVŘENÝ KRYT MOTORU A ZBRANÍ  
JDĚTE NA STRANU 10.  
NEPOUŽÍVEJTE DÍLY :**  
E2, E16, E18, E26, E28, E29,  
E30, E31, E33, E45, E48, E53

**APPLY DECAL- ENGINE SERIAL NUMBER  
SEE YOUR REFERENCE FOR THE EXACT NUMBER  
SÉRIOVÉ ČÍSLO MOTORU- POUŽIJTE OBTISK  
DĚLE VLASTNÍCH PODKLADŮ**

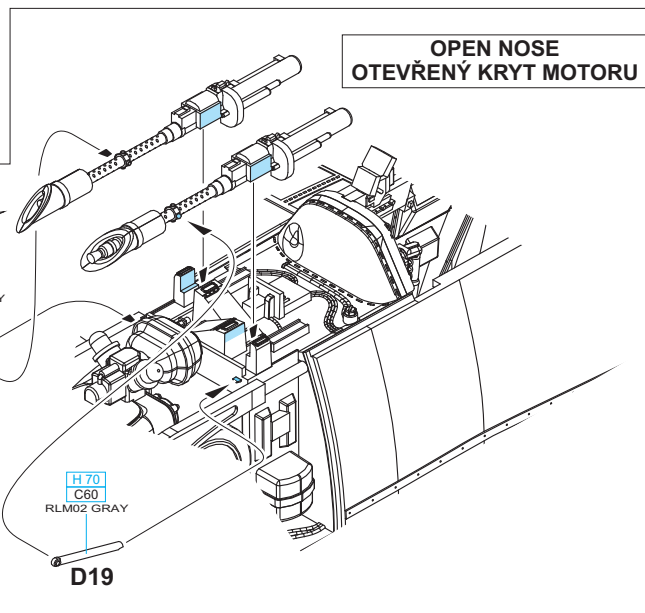
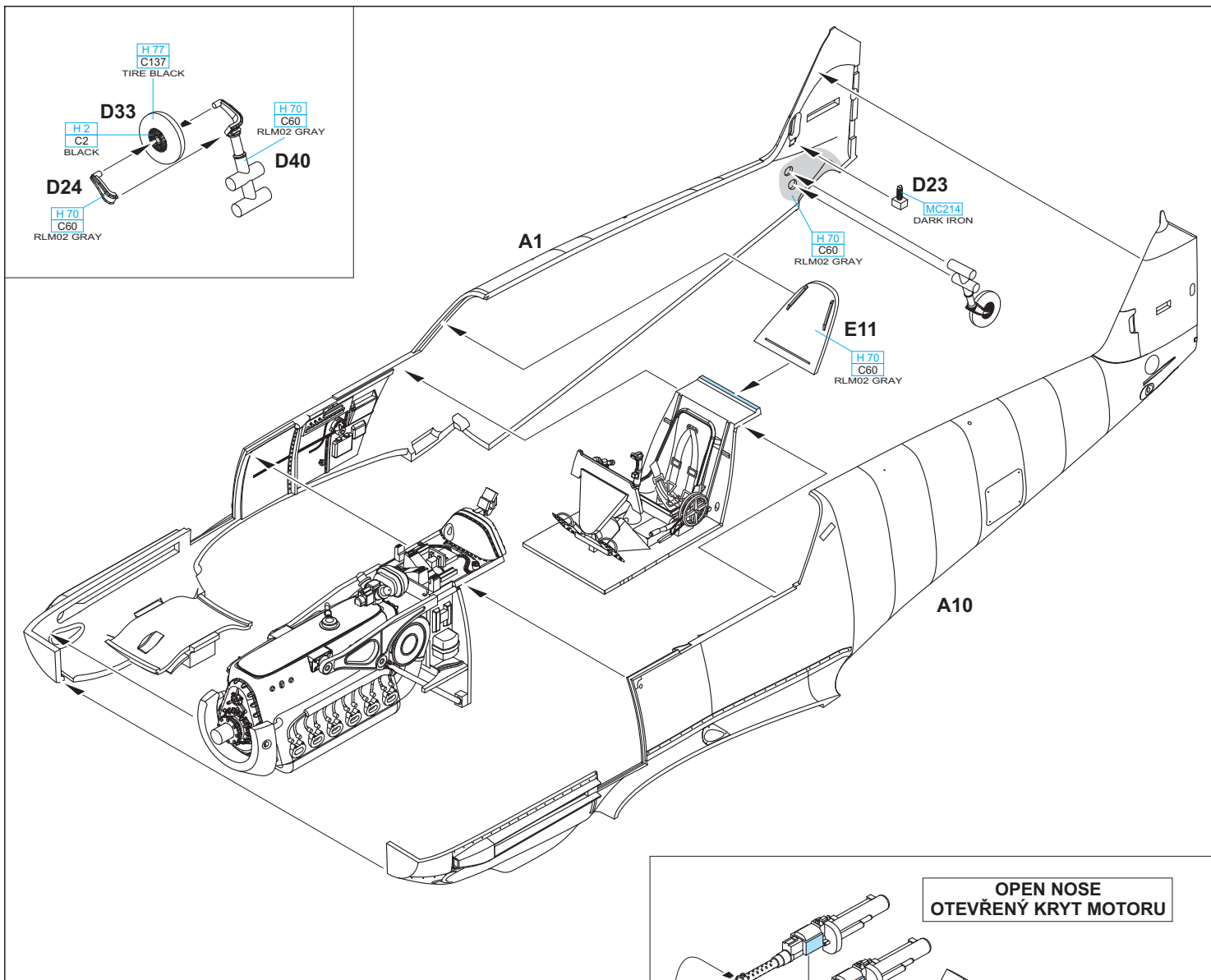

2 pcs.

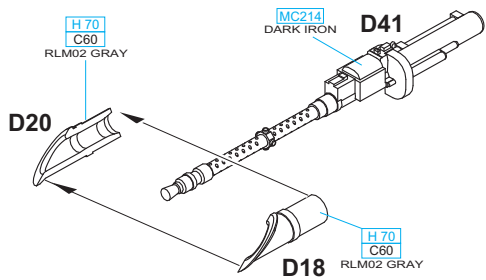

**EXHAUST PIPES INSTALLATION**  
**INSTALACE VÝFUKOVÝCH NÁTRUBKŮ**

1.

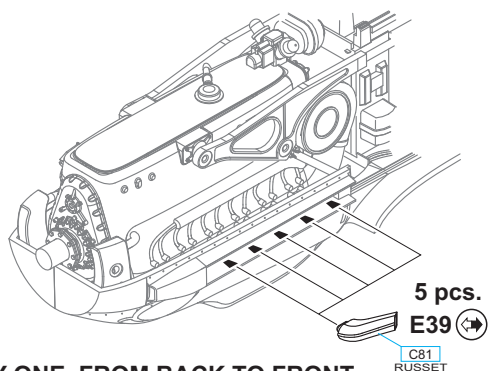

2.

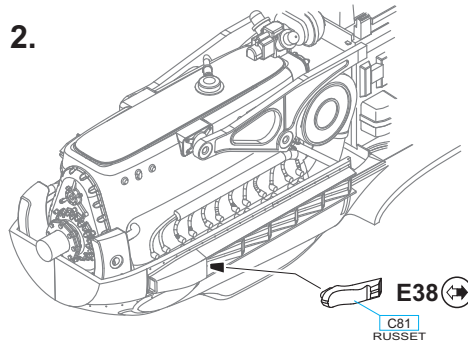

- ONE BY ONE, FROM BACK TO FRONT  
- JEDEN PO DRUHÉM, ODZADU DOPŘEDU

- E38 FITS WITHOUT THE GLUE  
- E38 NENÍ NUTNÉ LEPIT

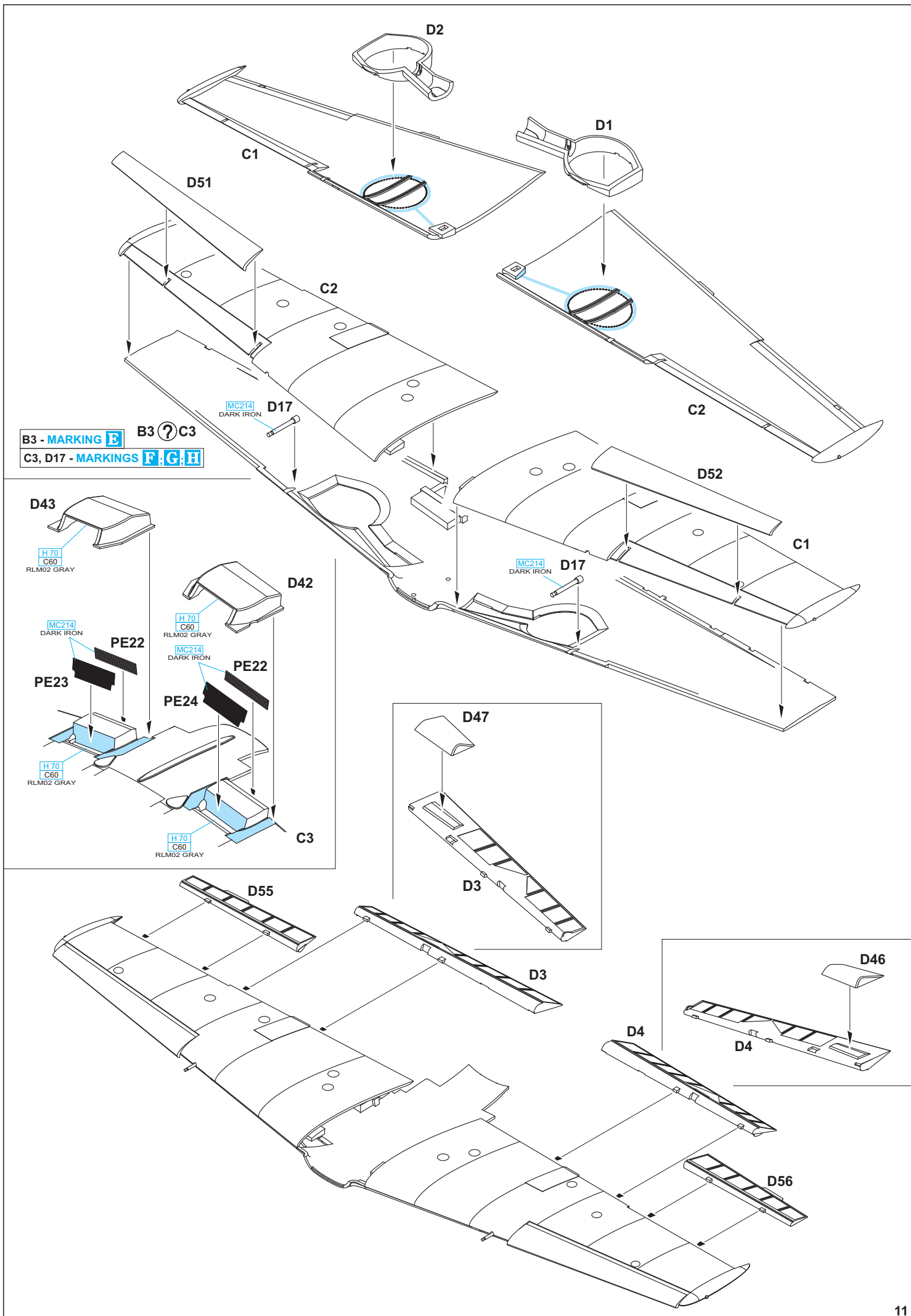

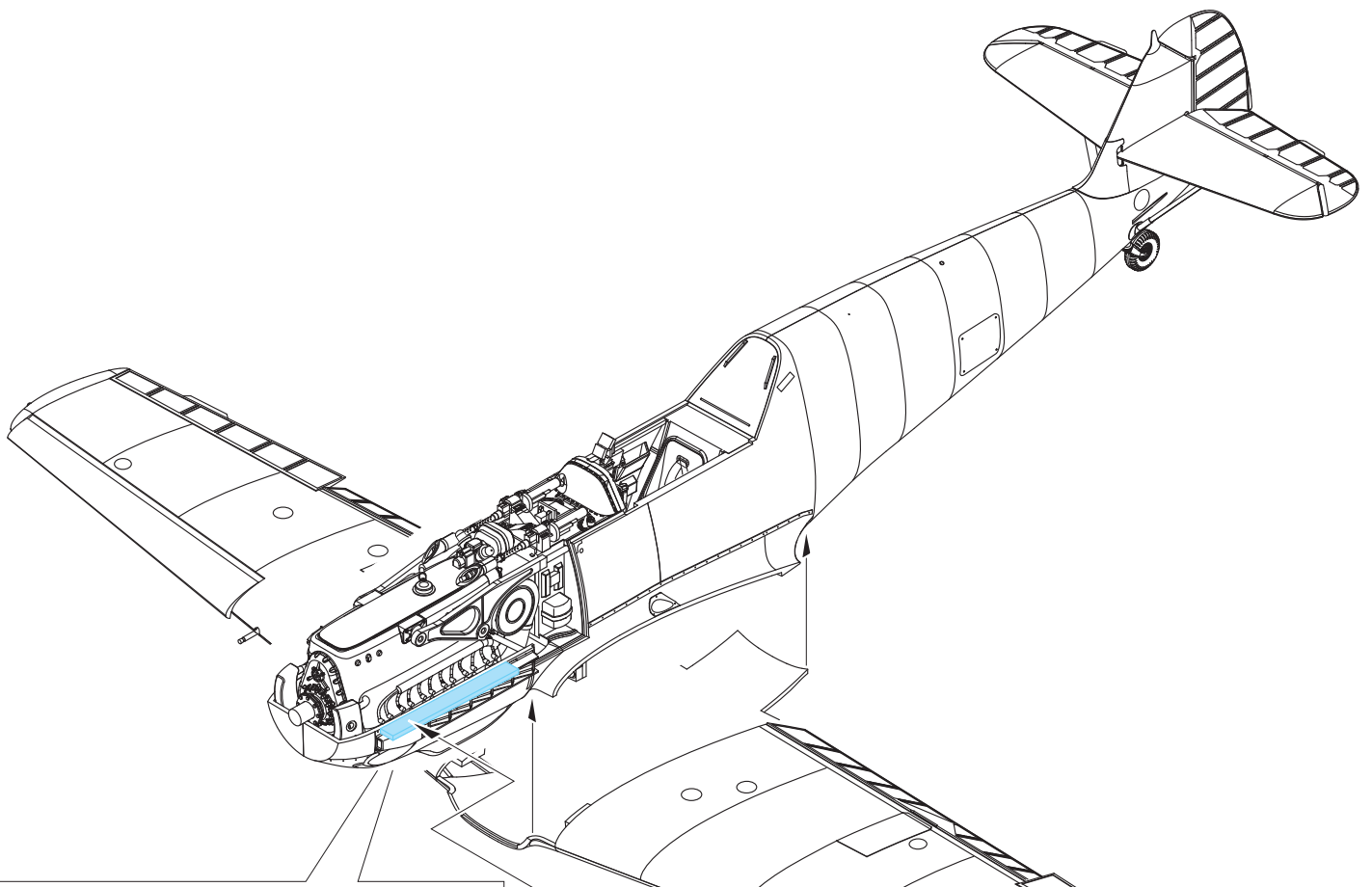

**E13**  
 H 70  
 C60  
 RLM02 GRAY

**A1, A10**

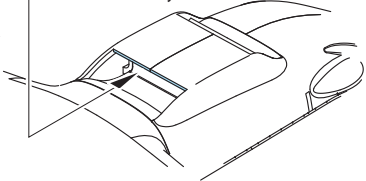

**E6** → **E5**  
 H 70  
 C60  
 RLM02 GRAY

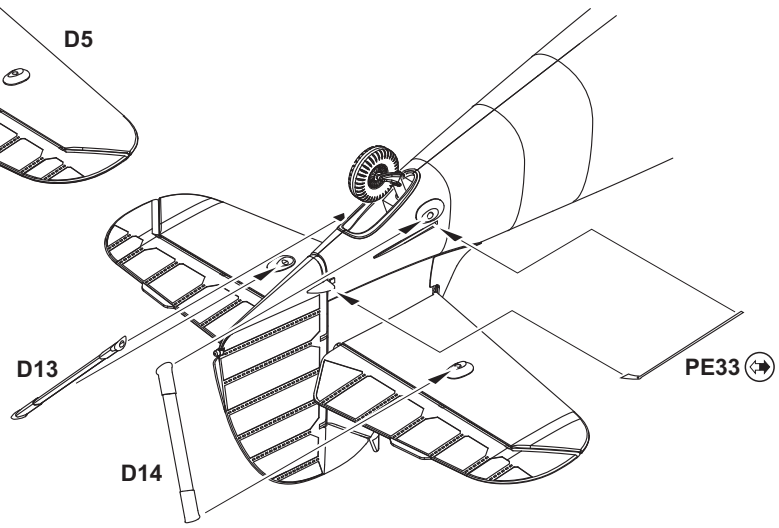
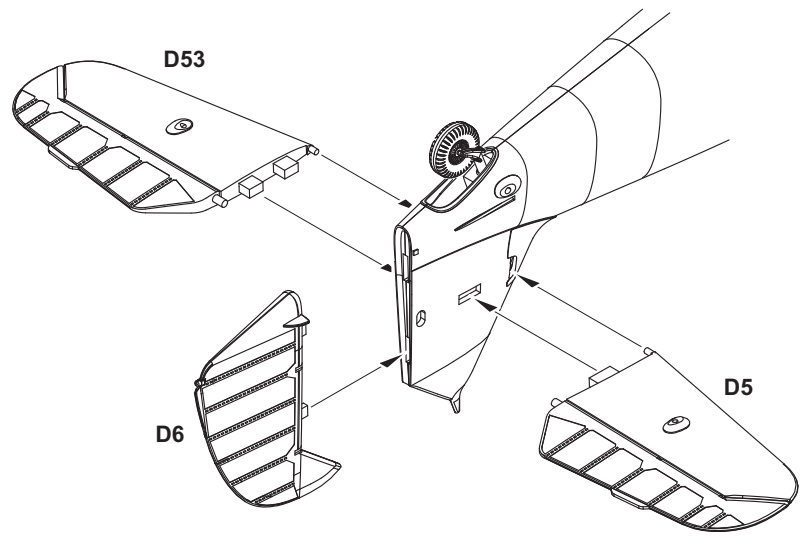

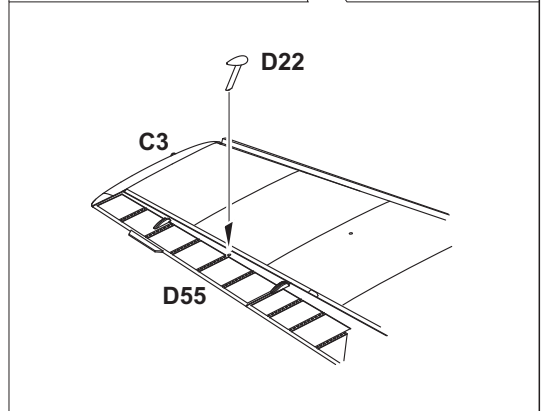
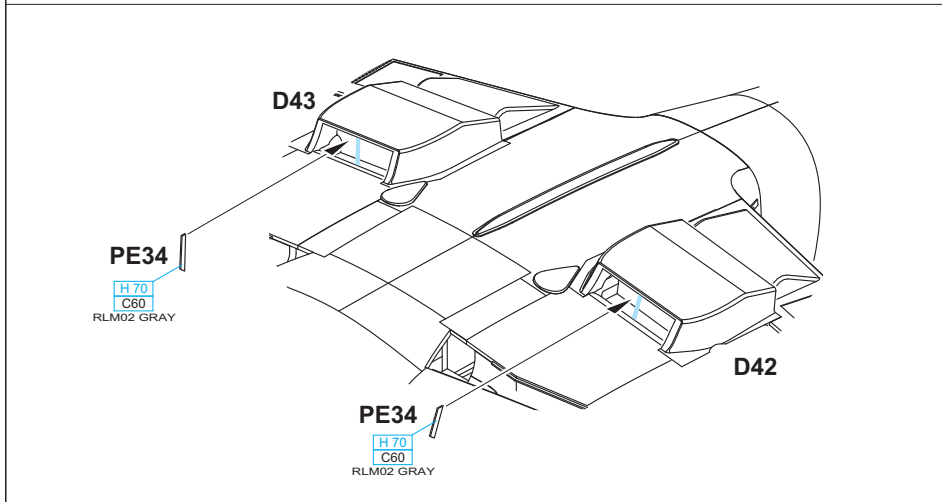
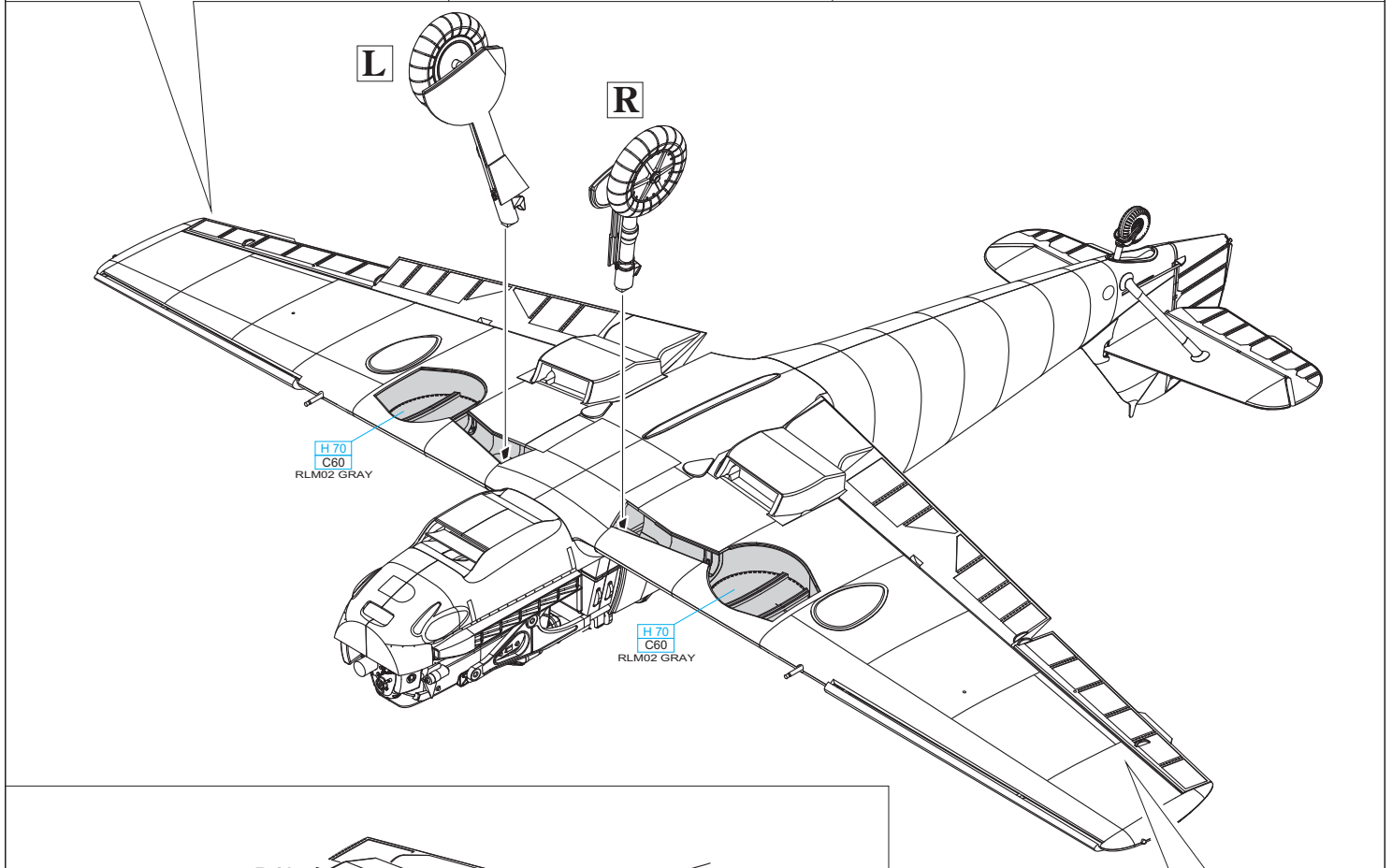
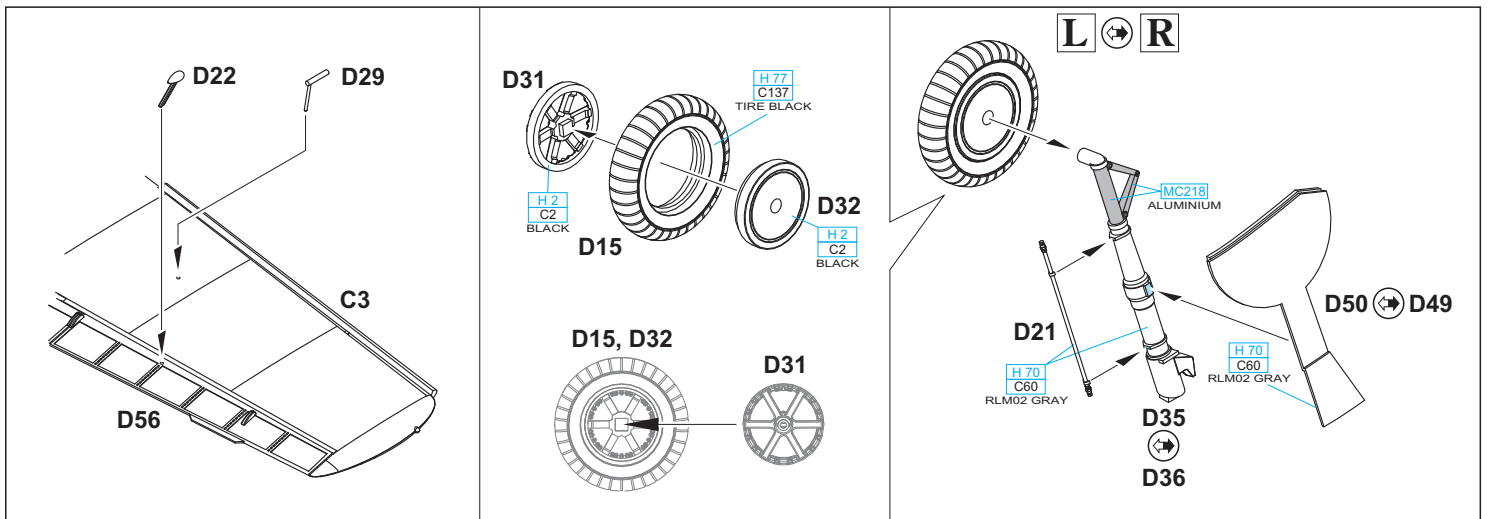

THE CORRECT POSITION OF THE UNDERCARRIAGE LEGS  
 SPRÁVNÁ POZICE PODVOZKOVÝCH NOH





FOR CLOSED NOSE  
SEE PAGE 10  
PRO ZAVŘENÉ KRYTY  
VIZ STR. 10

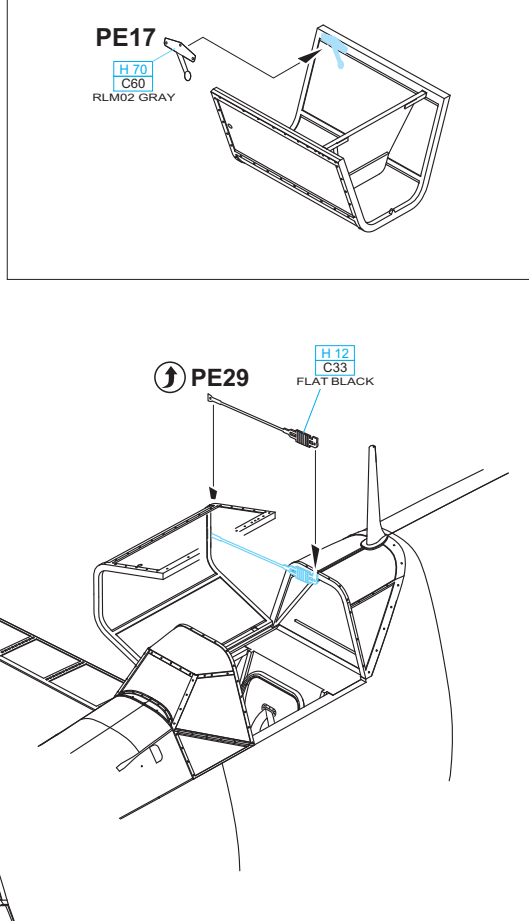
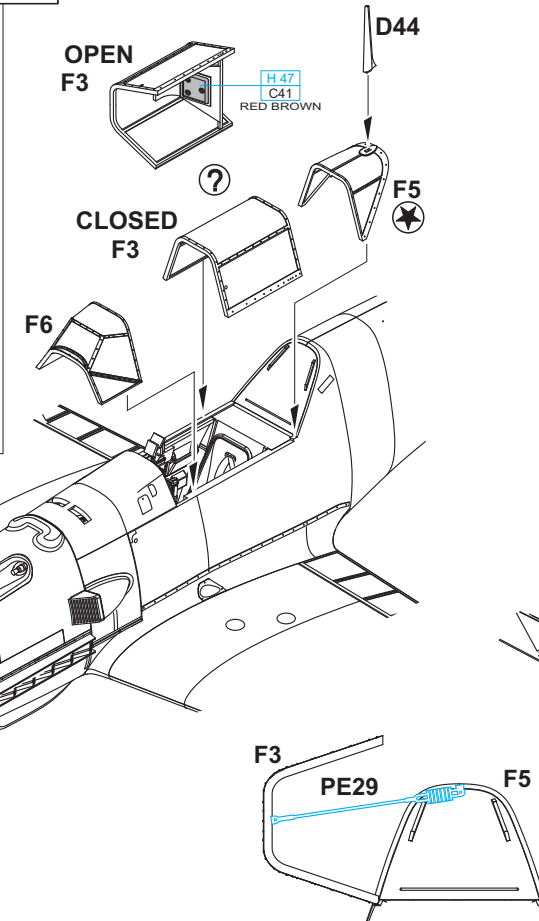
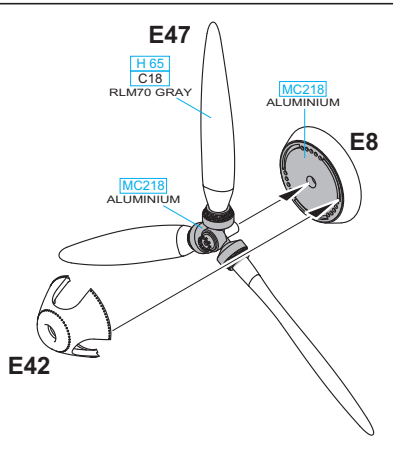
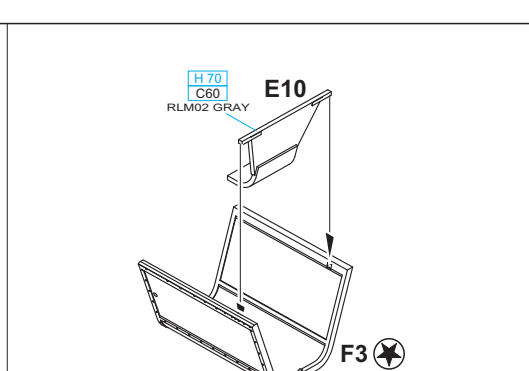
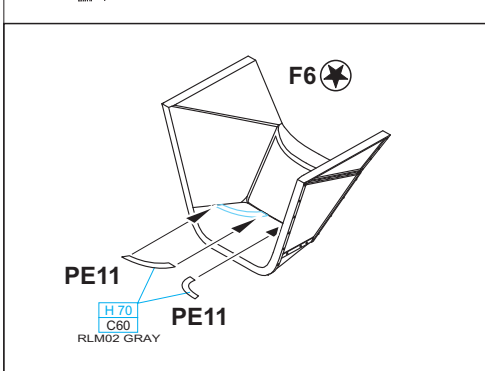
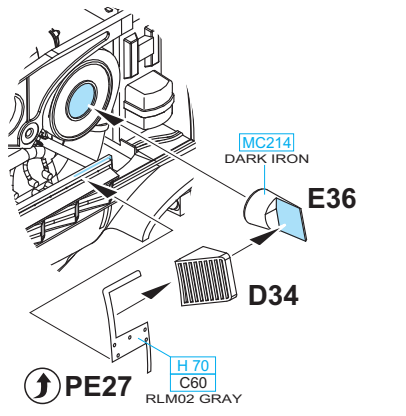
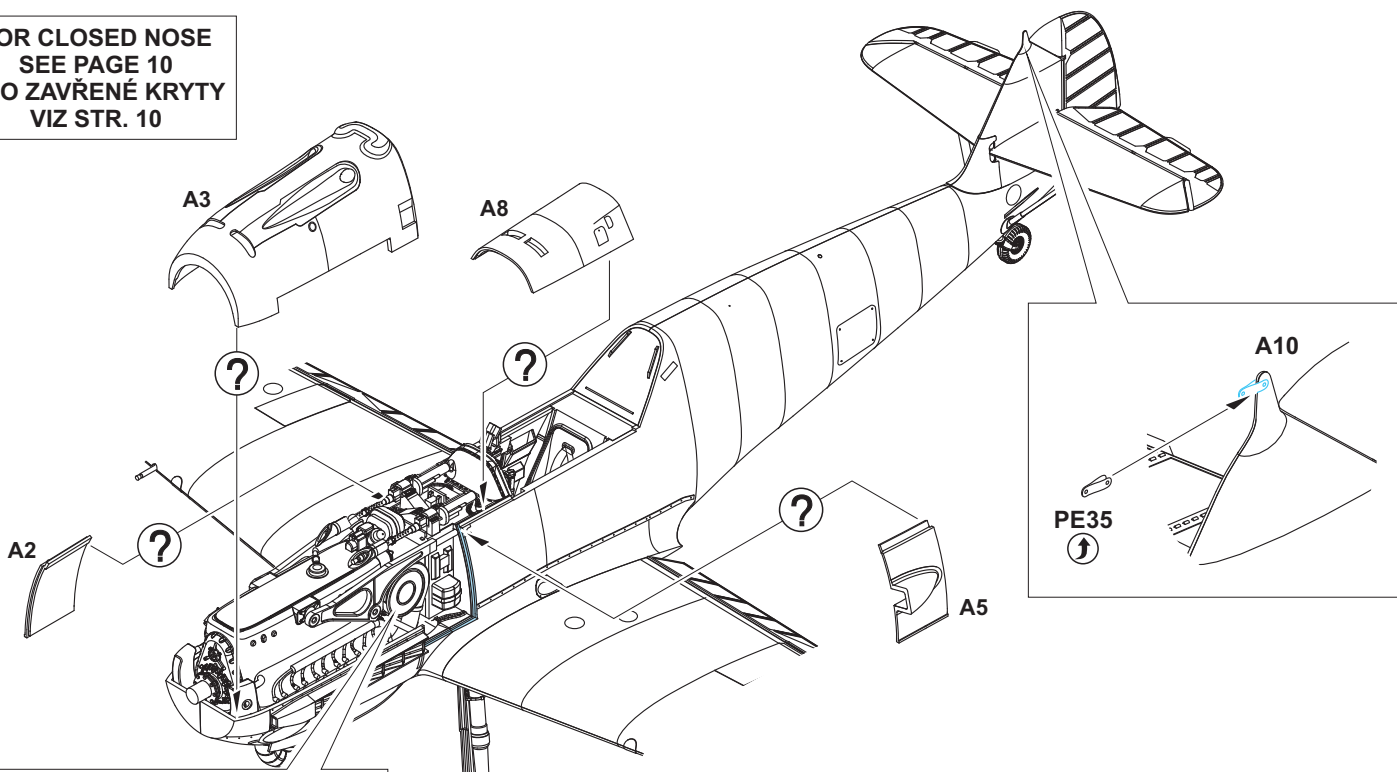

FOR CLOSED ENGINE COMPARTMENT ONLY

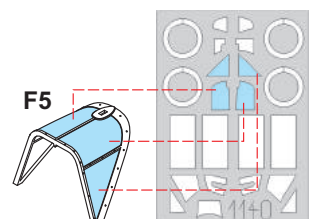
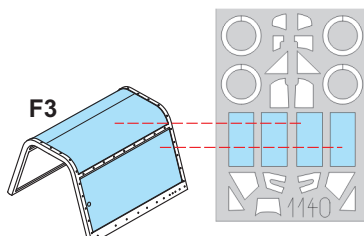
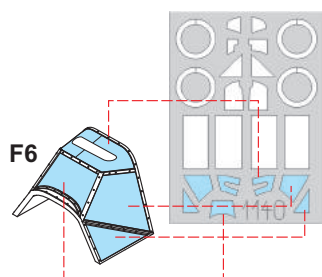
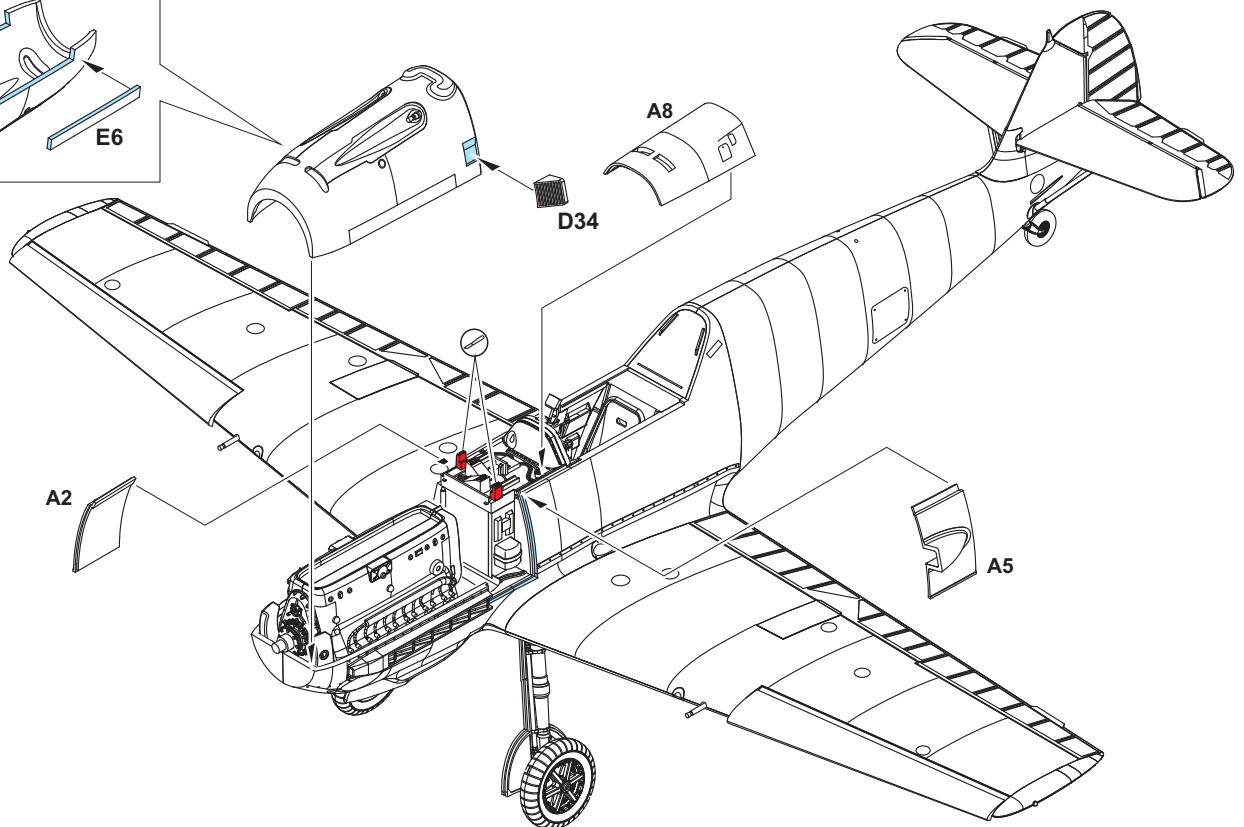
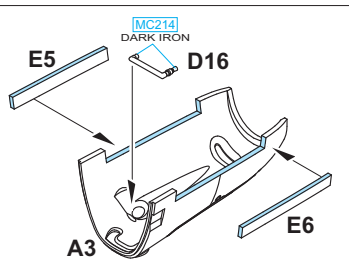
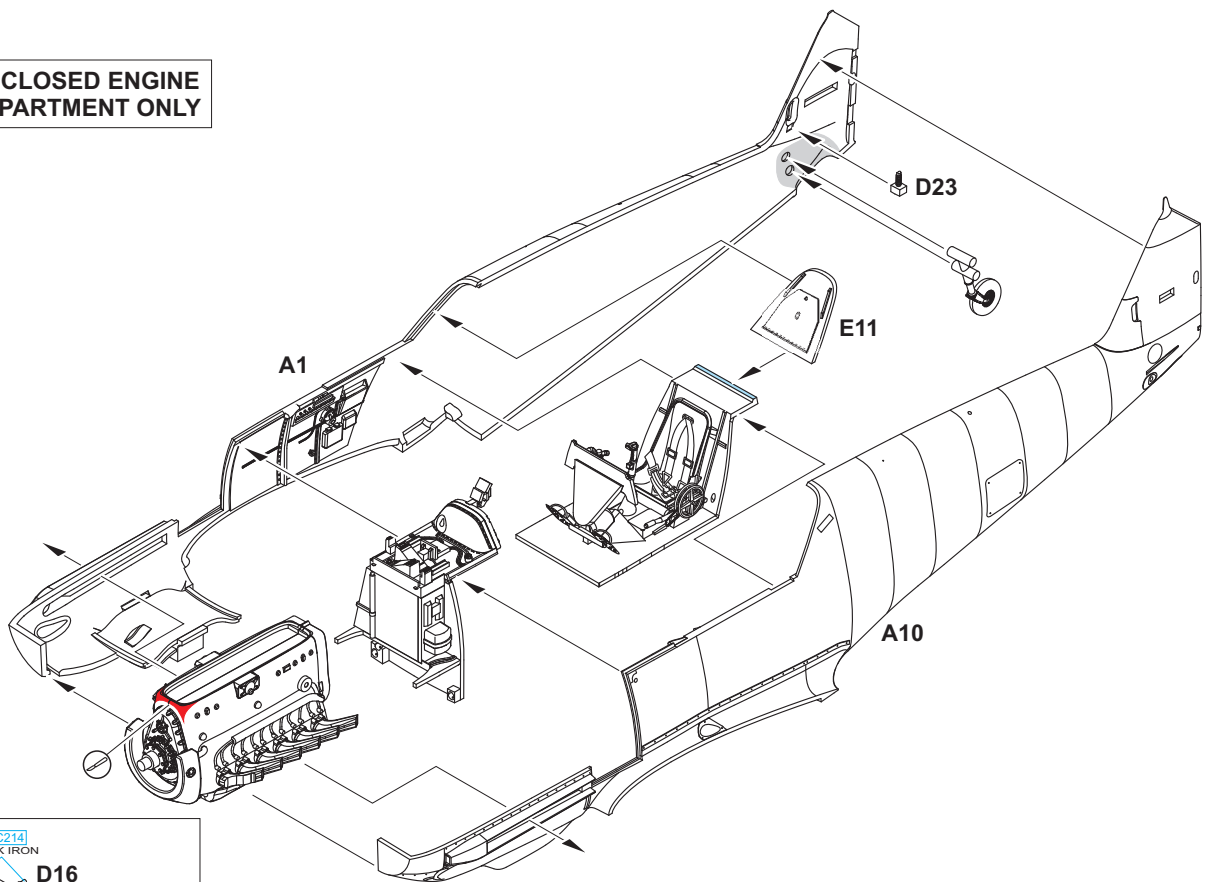

# A He 51B-1, Oblt. Hannes Trautloft, 2. J/88, Ávila, Spain, Fall 1936

This plane was flown by Hannes Trautloft, future and popular commander of JG 54. Trautloft was one of the first six fighter pilots sent to Spain. He scored his first victory on August, 25th 1936, but was himself shot down five days later, becoming the first German pilot shot down in the Spanish Civil War. He managed to crash land his He 51 and avoid capture, allowing him to raise his score in Spain to five victories. During the Second World War, he served in several command posts before being appointed commander (Geschwaderkommodore) of JG 54 on August 25th, 1940. After recording 20 aerial victories, he was awarded the Knight's Cross (Ritterkreuz des Eisernen Kreuzes) for the achievement, as well as for outstanding command of his unit, on the 27th of July, 1941. From December 4th, 1941, the planes of JG 54 began to sport the personal symbol of Trautloft's, the familiar green heart, so the unit became known as Grünherz-Geschwader. Trautloft recorded 58 victories prior to his appointment as Inspector of Eastern Fighters (Jagdflieger Inspizient Ost). Later, he was promoted to a post covering all day fighters. He is also known for his personal involvement in saving the lives of 160 American airmen sentenced to death in the Buchenwald concentration camp. Trautloft arranged for their transport to Luft Stalag III. Following the rebellion of prominent fighter commanders against Göring, Trautloft was released from his inspecting position and commanded the Fourth Flying School (4. Flieger Schule Division) in Strassburg. He entered service with the new Bundesluftwaffe as Brigade General in 1957 and acted as inspector until 1970. He passed away on 11th of January, 1995.

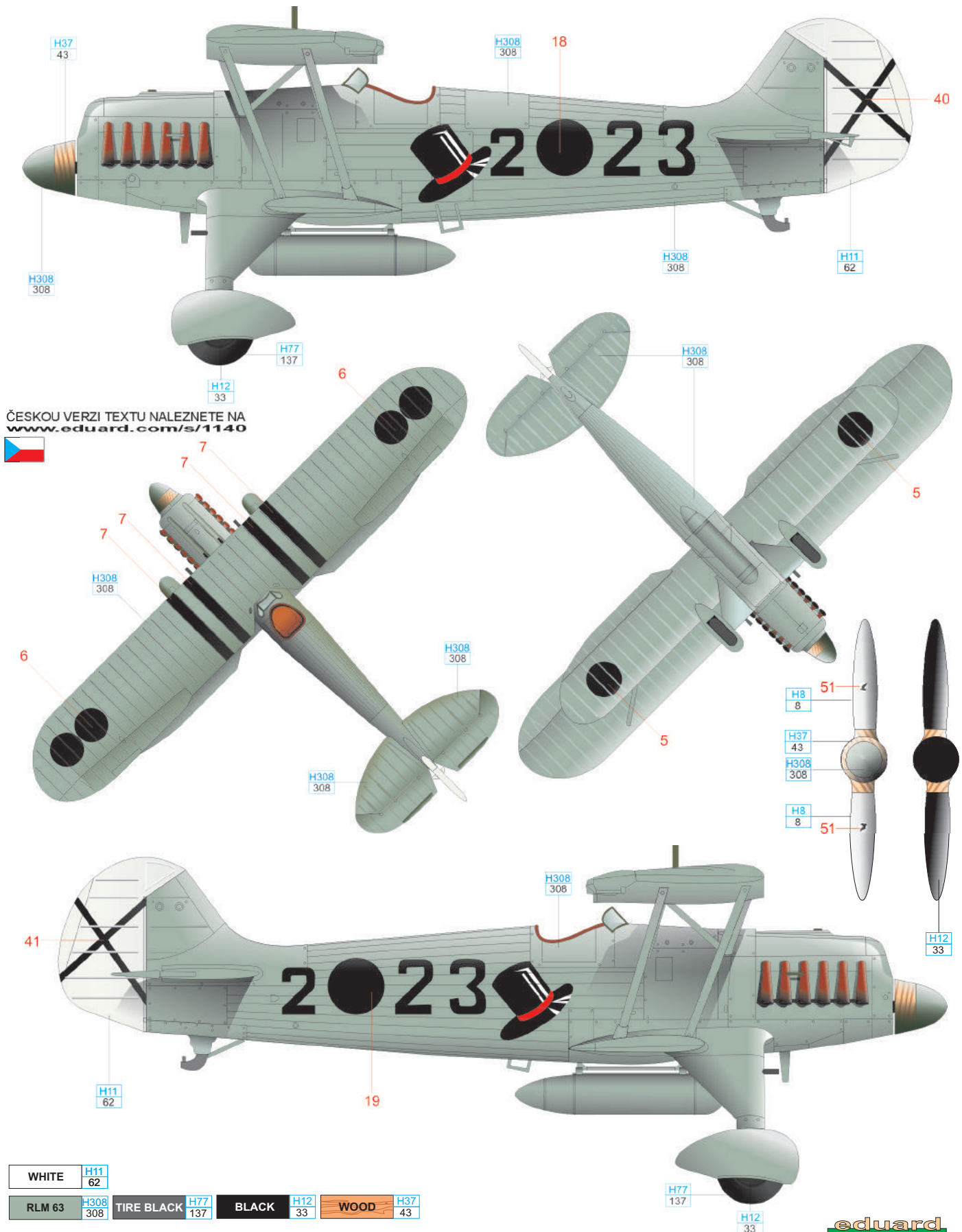

ČESKOU VERZI TEXTU NALEZNETE NA  
[www.eduard.com/s/1140](http://www.eduard.com/s/1140)



WHITE	H11 62	TIRE BLACK	H77 137	BLACK	H12 33	WOOD	H37 43
-------	--------	------------	---------	-------	--------	------	--------



# B Heinkel He 51C-1, Adolf Galland, 3. J/88, Calamocha, Spain, Spring 1938

The personal mount of Adolf Galland is sometimes portrayed in an upper surface three tone camouflage, but it is likely the third colour (RLM 61) was applied only after the plane was handed over from 3. J/88 to the Nationalist Gruppo de Cadena 4-G-2. Galland had the Maltese Cross as a personal symbol during the Spanish Civil War, having it painted in the black fuselage circle. Galland flew almost all of his 300 missions in Spain with this particular aircraft and, as he recalled 'there was hardly any part of the plane without a change or repair'. There was also the usual Mickey Mouse rendition (symbol of 3. Staffel) painted on the port side of the fuselage, plus the inscription 'Limon' under the cockpit for some period of time. The He 51C-1, with the bomb racks removed, did not differ from the He 51B-1 version. Galland did not score a single kill in Spain, a fact mainly resulting from his quite long service as a non flying staff officer during the first part of his Legion Condor mission, and also by flying only He 51s tasked with ground attack missions. He made up for it during the Second World War, scoring 94 victories prior to becoming General of Fighter Pilots (General der Jagdflieger) on the 22nd of November 1941. Following the rebellion of prominent fighter commanders against Hermann Göring, Galland was demoted and relieved of his post, but was allowed to form Jagdverband 44 (JV 44) for Me 262 operational use as an interceptor. He scored seven kills flying the jet and ended the war with a score of 104. Galland was held in military custody for two years after the war, and from 1948 he acted as consultant to the Argentine Air Force. Later, he became a successful businessman. Galland died on 9th of February, 1966 at the age of 94. He was one of only 27 German soldiers honoured with the Iron Knight's Cross with Oak Leaves, Swords and Diamonds.



# C Heinkel He 51B-1, Harro Harder, 1. J/88, Battle of Brunete, Spain, July 1937

The personal aircraft of Hpt. Harro Harder, Staffelfkapitän of 1. J/88, as it appeared during the Battle of Brunete (from July 6th to 25th, 1937). Later, the non-regulation swastika on the fuselage and upper wing was modified to the white 'X' form. Harder eventually achieved eleven air victories during the Spanish Civil War, but only one flying the He 51, when he shot down a Republican I-16 near Bilbao on the 4th of January, 1937. He recorded all of his following victories flying the Bf 109. In total, he managed to shoot down 17 aircraft before being shot down himself in a Bf 109E-3 close to the Isle of Wight on August 12th, 1940. At the time, he was Gruppenkommandeur of III./JG 53, taking over after the death of Werner Mölders just a month prior to his own death.

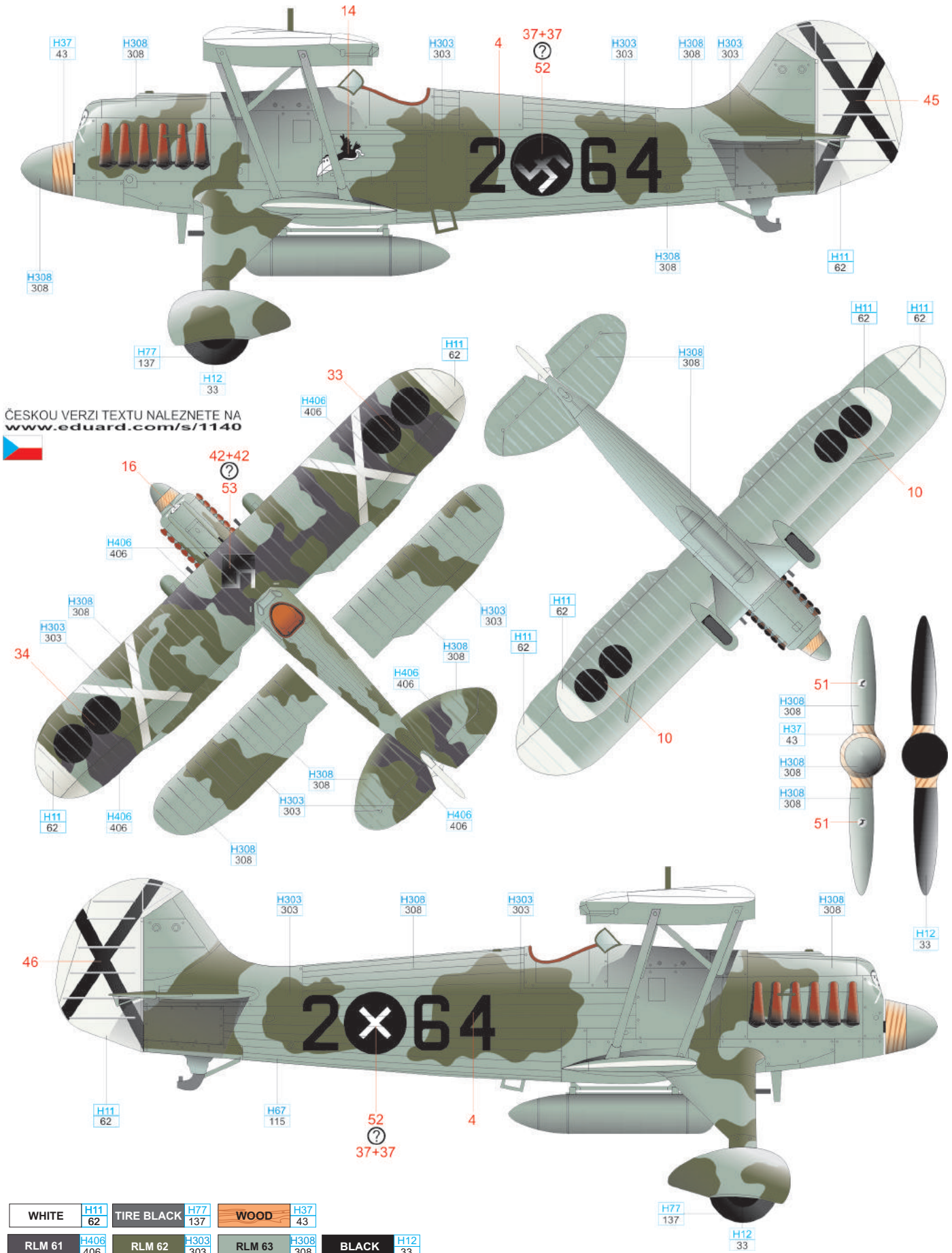



# D Heinkel He 51B-1, Stabsarzt Dr. Heinrich Neumann, Medical Battalion San/88, Spain, 1938

This colourful aircraft was used by Stabsarzt (Captain) Dr. Heinrich Neumann, member of San/88 medical unit. Neumann, an amateur pilot, used to borrow different aircraft for travelling to observe his patients. He crashed one He 51 (No. 2-85) while landing in December 1937, but the accident did not discourage him from further flying. He used this plane belonging to 3. J/88 in 1938. The plane had a red cross painted in a black roundel and also sported a defensive German inscription „Tut mir nicht's ich tu Euch auch nicht's“ (Do not do anything to me, as I am not doing anything to you!) and the inscription 'Annelis' under the cockpit. The Mickey Mouse badge was the marking of 3. J/88. Neumann was awarded the Spanish Cross in Silver (Spanienkreuz in Silber) for his service in Spain. He was assigned to the new 7. Parachute Division (7. Flieger-Division) later in 1938, undergoing full parachute training. He subsequently took part in many paratroop combat operations, including the Invasion of Crete, where he also commanded the troops directly in combat. From 1942 he served as division surgeon in Russia. Neumann was a brave man credited with many awards, including the Knight's Cross. He practised medicine in Hamburg after the war and died on May 19 of 2005.

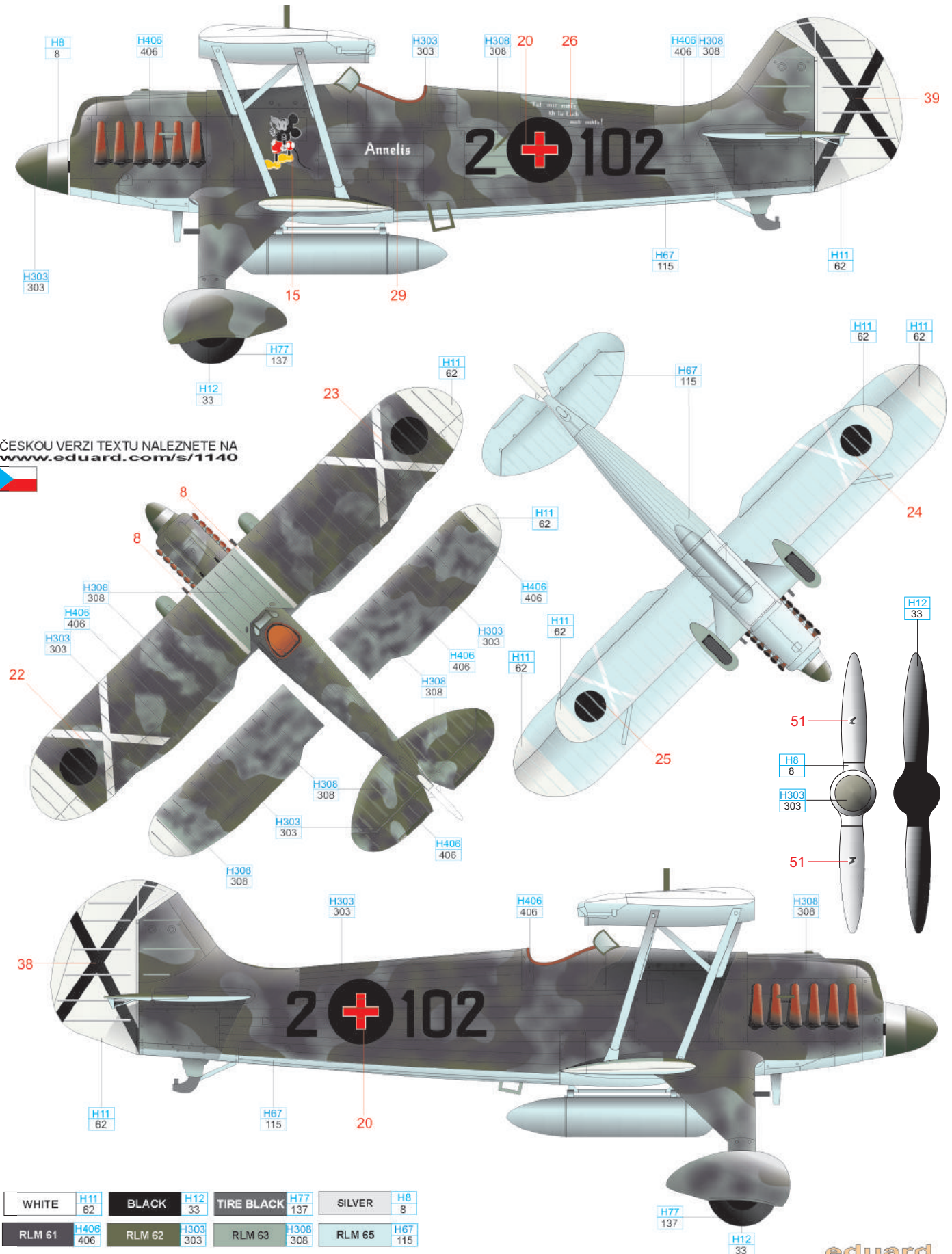

ČESKOU VERZI TEXTU NALEZNETE NA  
[www.eduard.com/s/1140](http://www.eduard.com/s/1140)



WHITE	H11 62	BLACK	H12 33	TIRE BLACK	H77 137	SILVER	H8 8
RLM 61	H406 406	RLM 62	H303 303	RLM 63	H308 308	RLM 65	H67 115

# E Bf 109E-1, Oblt. Siebelt Reents, Staffelkapitän 1. J/88, León, Spain, Spring 1939

Aircraft of 1. J/88 sported the emblem known as 'Wooden Eye' (Holzauge) on the port side of the fuselage, and the originator of it was Siebelt Reents. He was also commanding officer of the unit from the 2nd of September, 1938. Reents recorded his only aerial victory in Spain, shooting down a Polikarpov I-16 on February 6th, 1939. During the Second World War, he served mainly as a ground attack pilot and flew with a wide variety of units and areas, including Africa. There, he attacked ground targets flying a Bf 109F-4 Trop with tremendous success. He, for example, seriously damaged a British destroyer, hitting it with two bombs. From the spring of 1943, he acted as commanding officer of the training unit II./SG 101 located at the Paris-Orly airfield. After this break he returned to operational flying as an interceptor pilot in Romania. Wounded in combat, he returned to training new attack pilots. Reents passed away at the ripe old age of 101, on 11th of May 2012.

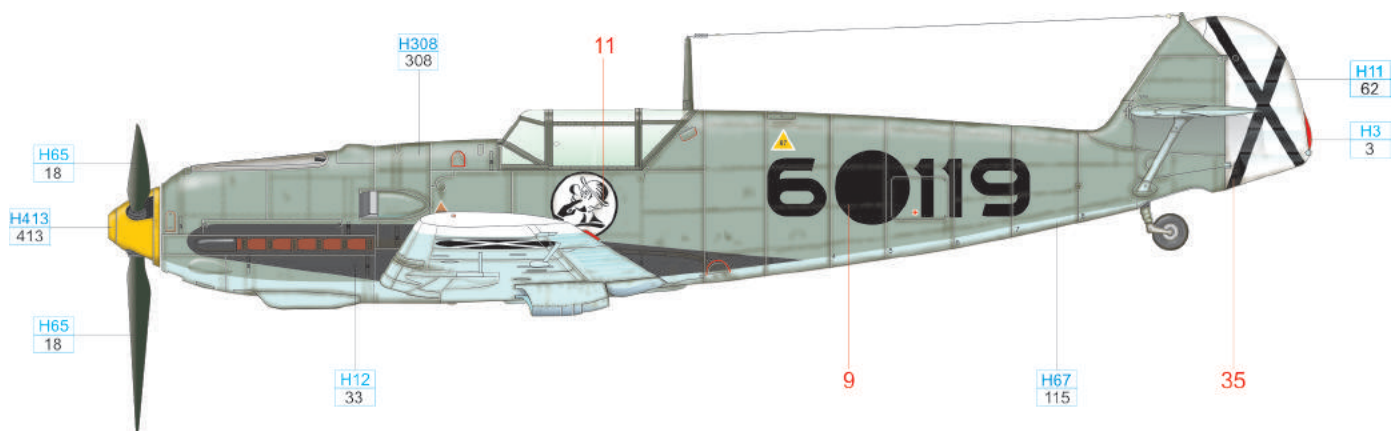

ČESKOU VERZI TEXTU NALEZNETE NA [www.eduard.com/s/1140](http://www.eduard.com/s/1140)

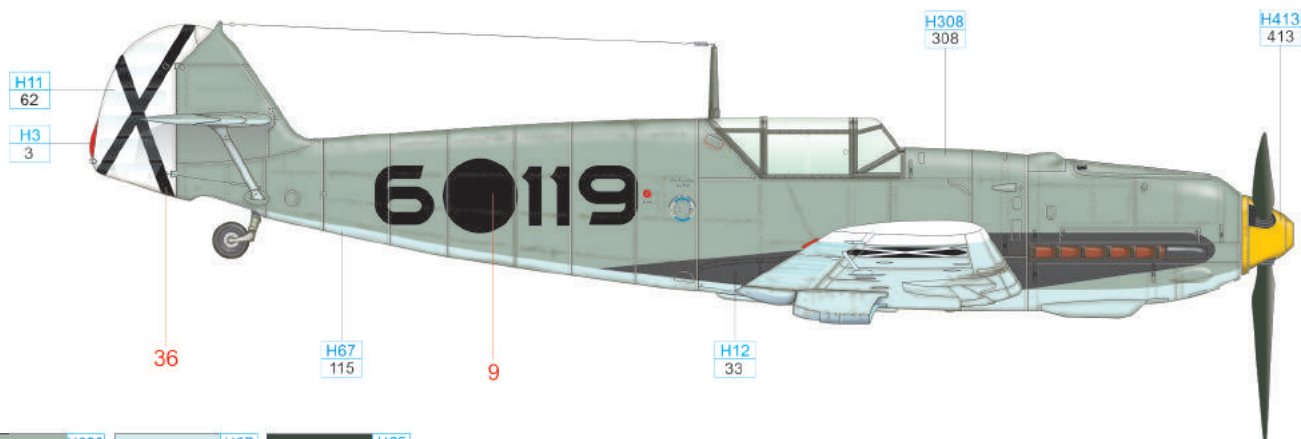
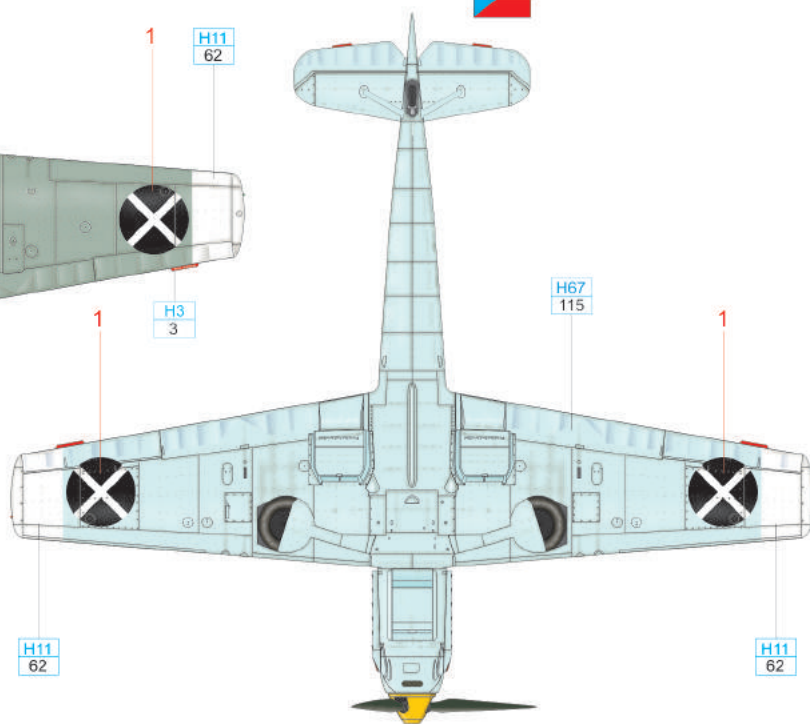
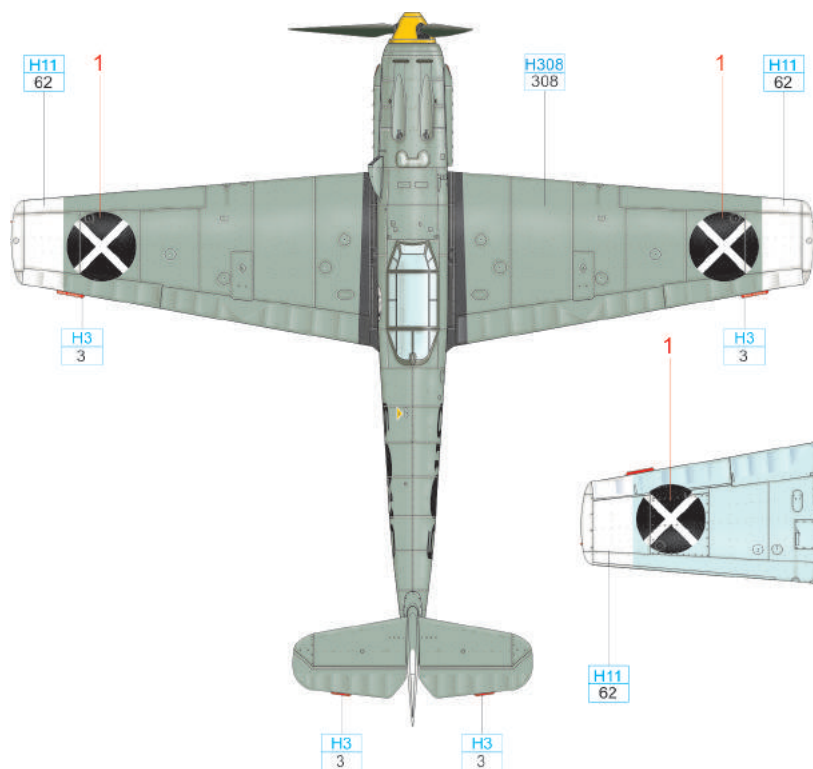

RLM 63	H308 308	RLM 65	H67 115	RLM 70	H65 18
RED	H3 3	WHITE	H11 62	BLACK	H12 33
				RLM 04	H413 413



# F Bf 109E-3, Oblt. Hans Schmoller-Haldy, 3. J/88, Spain, 1938

Hans Schmoller-Haldy was sent to Spain just at the end of the war, so it is no surprise he did not score any victory there. His Messerschmitt sported a personal emblem – the overflowing beer glass with the letters 'CP' on it. They stand for Cardinal Puff and refer to the famous beer drinking game originating in the USA during prohibition. It seems likely Schmoller-Haldy was a great fan of both beer and the game... During the Second World War, he served with JG 54 and recorded 14 aerial victories. Later, he served as a member of Galland's fighter command staff. After the war, Schmoller-Haldy entered service with the post war Bundesluftwaffe with the rank of Brigadier General.

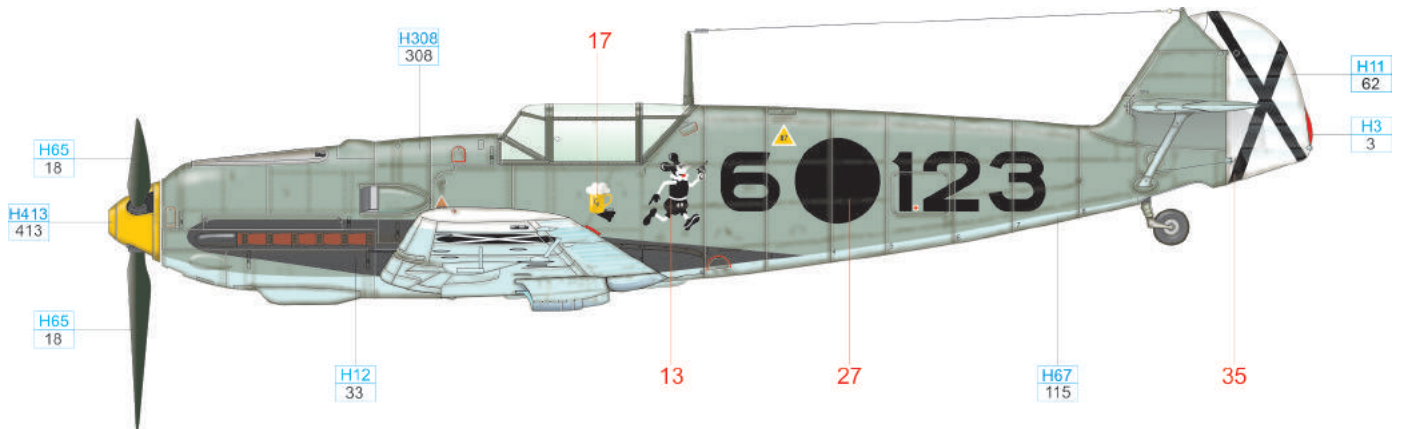

ČESKOU VERZI TEXTU NALEZNETE NA  
[www.eduard.com/s/1140](http://www.eduard.com/s/1140)

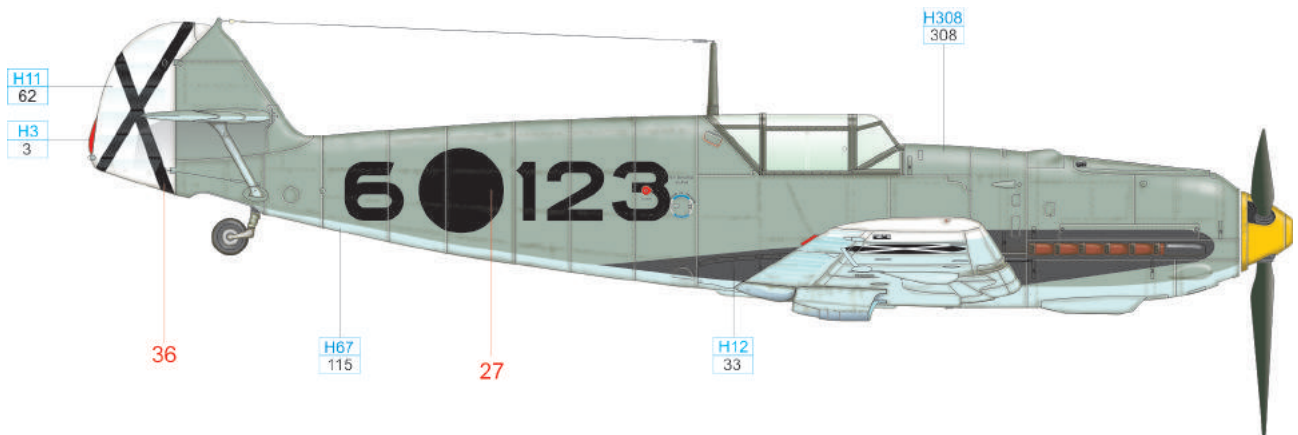
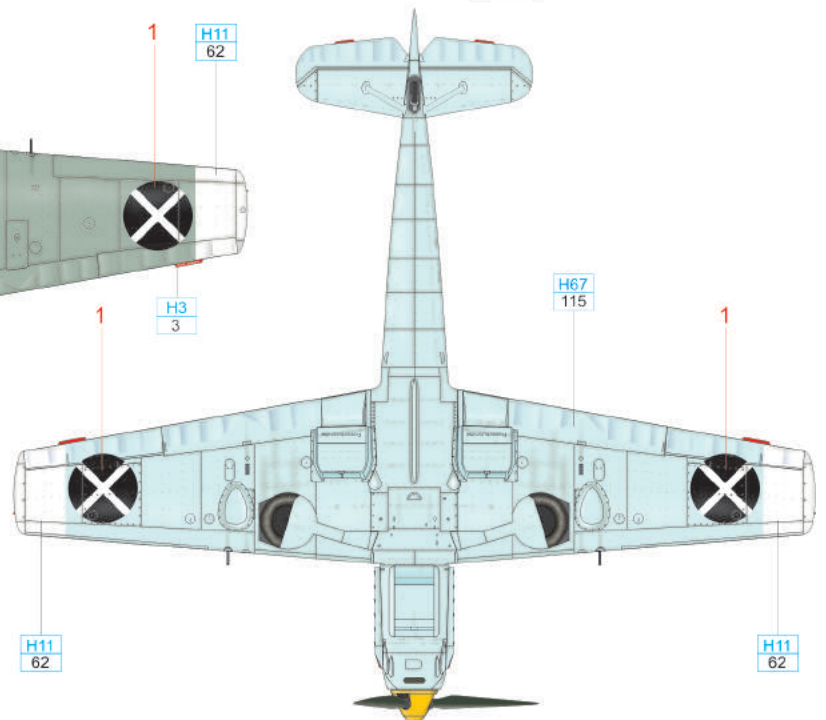
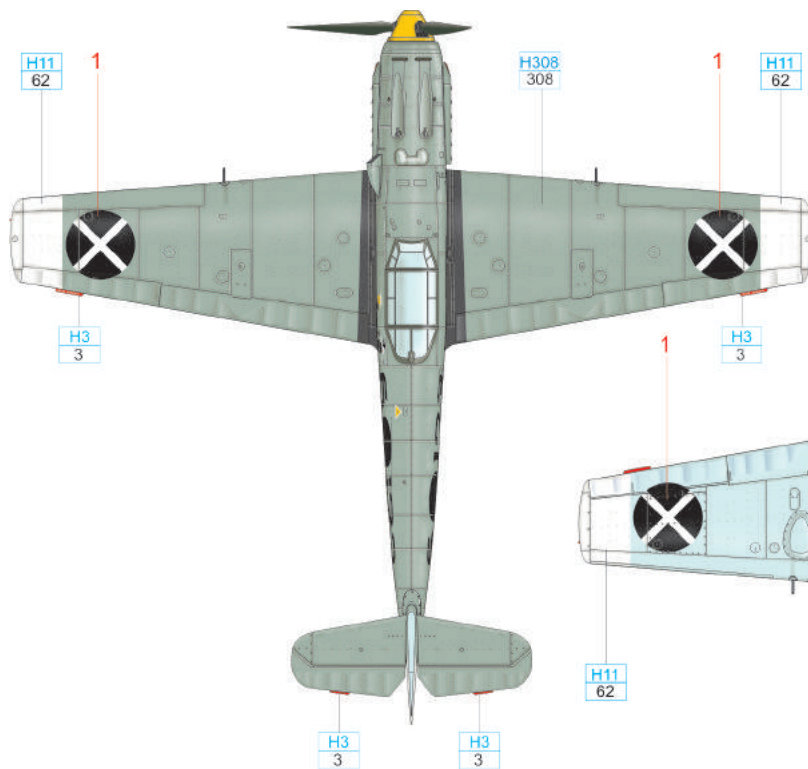

RLM 63	H308 308	RLM 65	H67 115	RLM 70	H65 18
RED	H3 3	WHITE	H11 62	BLACK	H12 33
				RLM 04	H413 413

# G Bf 109E-3, 2. J/88, Catalunyan Front, Spain, Early 1939

This aircraft, with the typical Top Hat marking of 2.J/88, also sported the inscription 'Mors-Mors!' on the port side of the engine cowl. The slogan is a slang answer to the ancient Hamburg greeting 'Hummel Hummel!'. It is unknown, whether this part of the greeting was painted on the starboard side of the cowl. It is also unknown, which pilot flew this plane, but the above mentioned greeting indicates, it was probably a man with some connections to the famous harbour city. It is unfortunately not clear which colour was applied on the upper surfaces of Bf 109s serving in Spain. Some sources insist on light green-grey RLM 63, while others support the darker RLM 62 as the correct colour. Undersurfaces were certainly RLM 65.

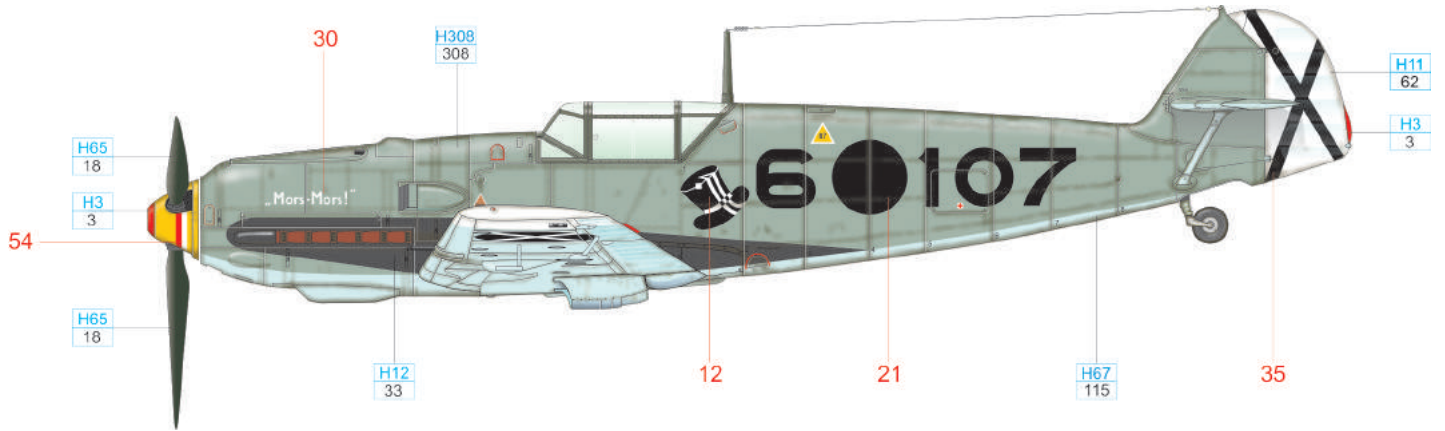

ČESKOU VERZI TEXTU NALEZNETE NA  
[www.eduard.com/s/1140](http://www.eduard.com/s/1140)

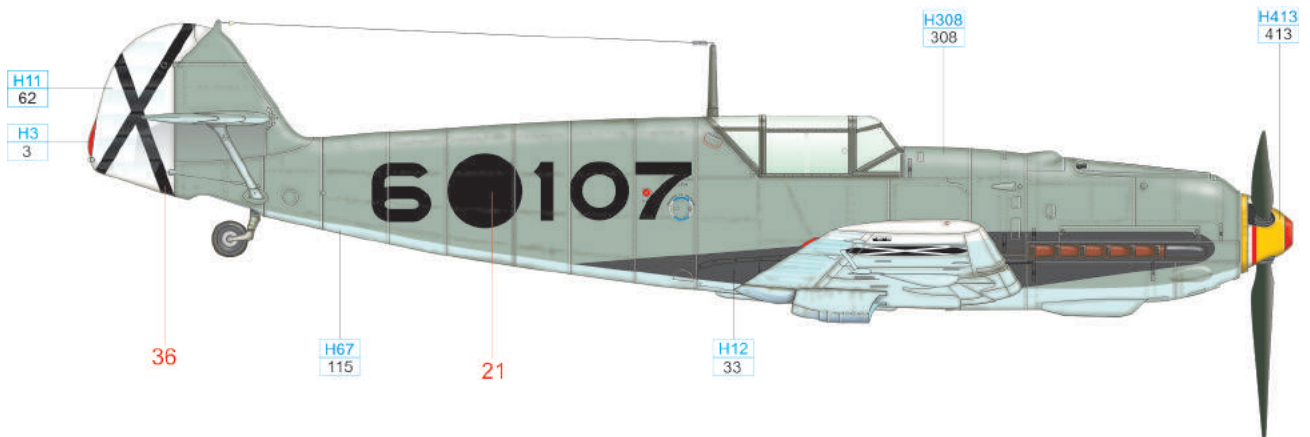
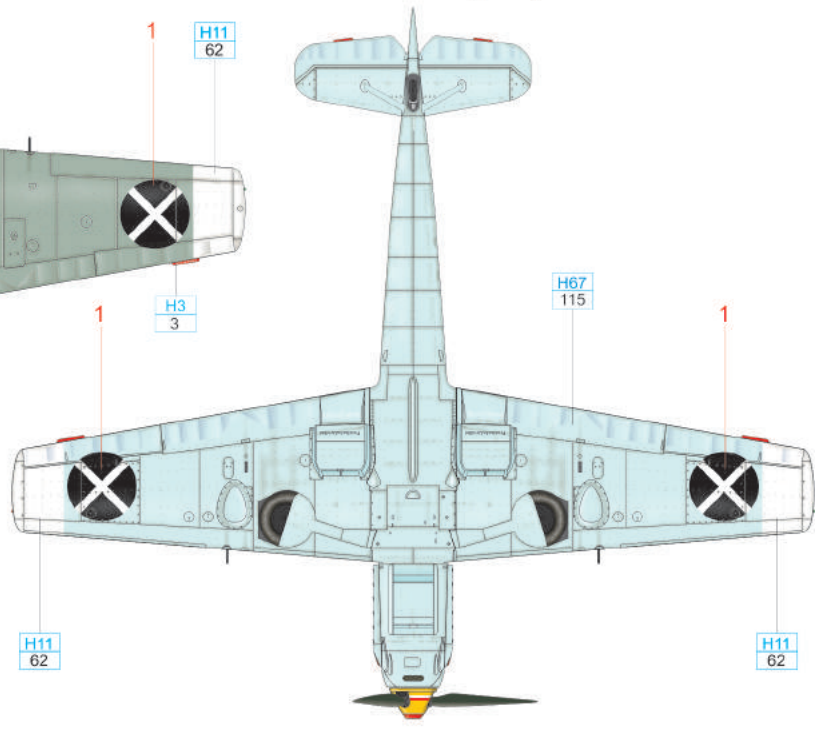
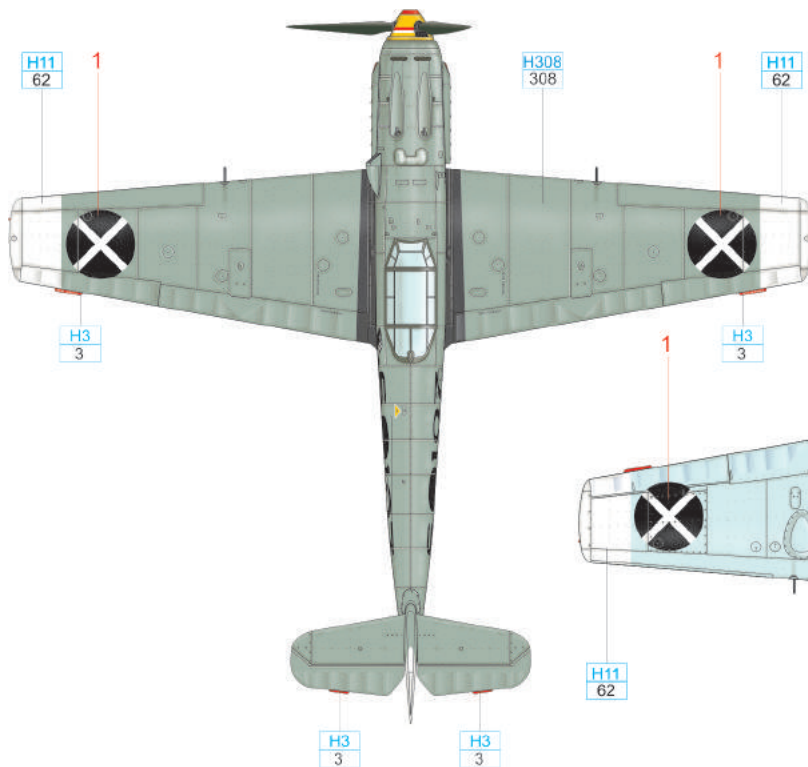

RLM 63	H308 308	RLM 65	H67 115	RLM 70	H65 18
RED	H3 3	WHITE	H11 62	BLACK	H12 33
				RLM 04	H413 413

# H Bf 109E-3, Lt. Kurt Sochatzy, 3.J/88, Spain, Spring 1939

This was the aircraft of Austrian-born pilot Kurt Sochatzy, who served with Legion Condor from February to June 1939. He did not get any kills in that timeframe, but was honoured for his service with a Spanish Bronze Cross with Swords. On his return to Germany, Sochatzy was transferred to I./JG 76. He participated in the Polish campaign and was promoted to the rank of Oberleutnant. In January 1940, Sochatzy was appointed to Jagdfliegerschule 5, where he trained such future aces as Hans-Joachim Marseille and Walter Nowotny. Sochatzy was appointed Staffelkapitän of 7./JG 3 and after operations over the Channel without a victory, he led the unit during Operation Barbarossa. On the 26th of June, 1941 he claimed his first victory, shooting down an SB-2. His tally rose to 38 aerial victories plus 27 aircraft on the ground along with two trains destroyed. After those achievements, he was shot down during combat with an Il-2 and saved himself by resorting to his parachute, but was captured after landing and arrested. He returned home in 1947.

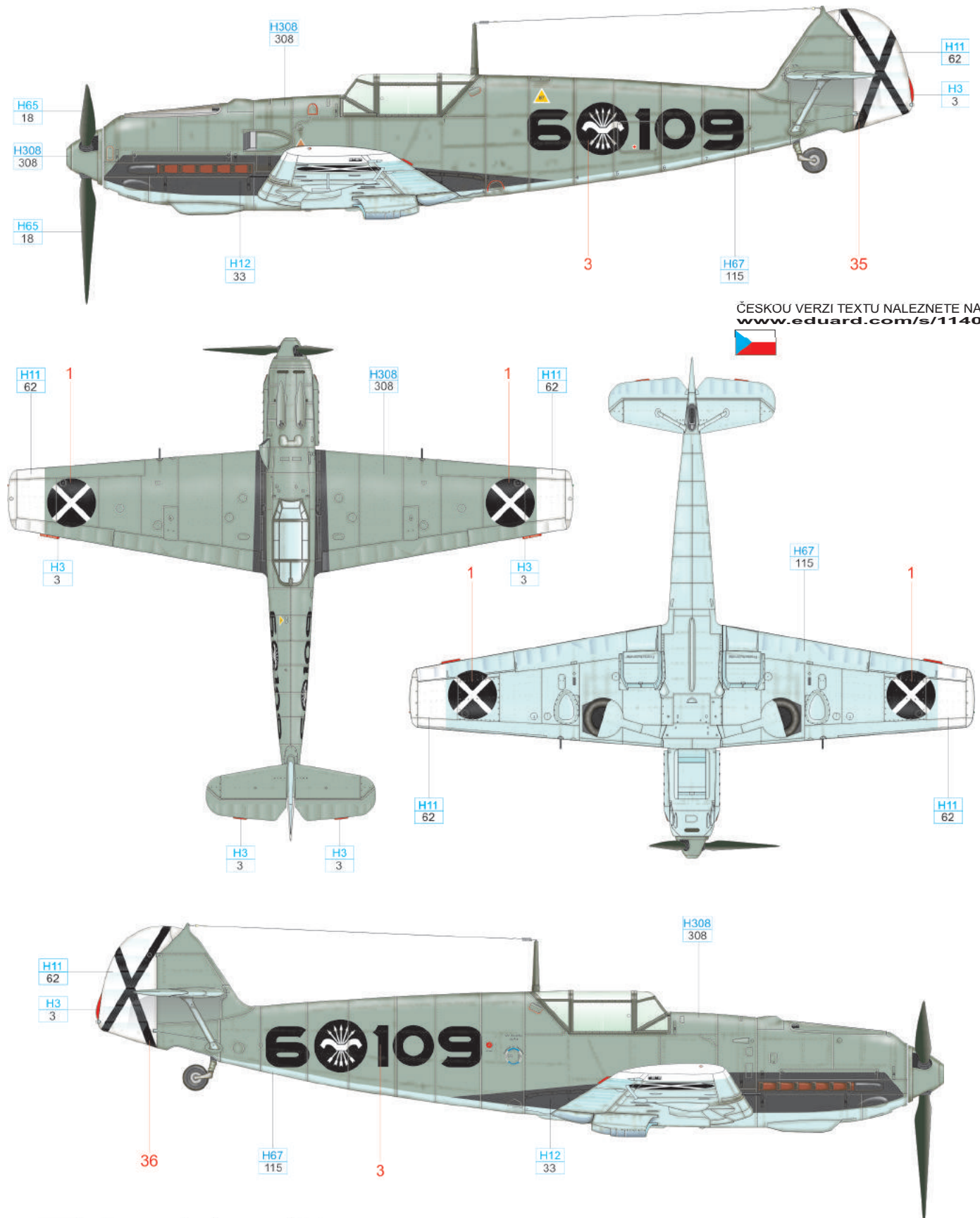

ČESKOU VERZI TEXTU NALEZNETE NA  
[www.eduard.com/s/1140](http://www.eduard.com/s/1140)



RLM 63	H308 308	RLM 65	H67 115	RLM 70	H65 18
RED	H3 3	WHITE	H11 62	BLACK	H12 33



