

ACADEMY

HOBBY MODEL KITS

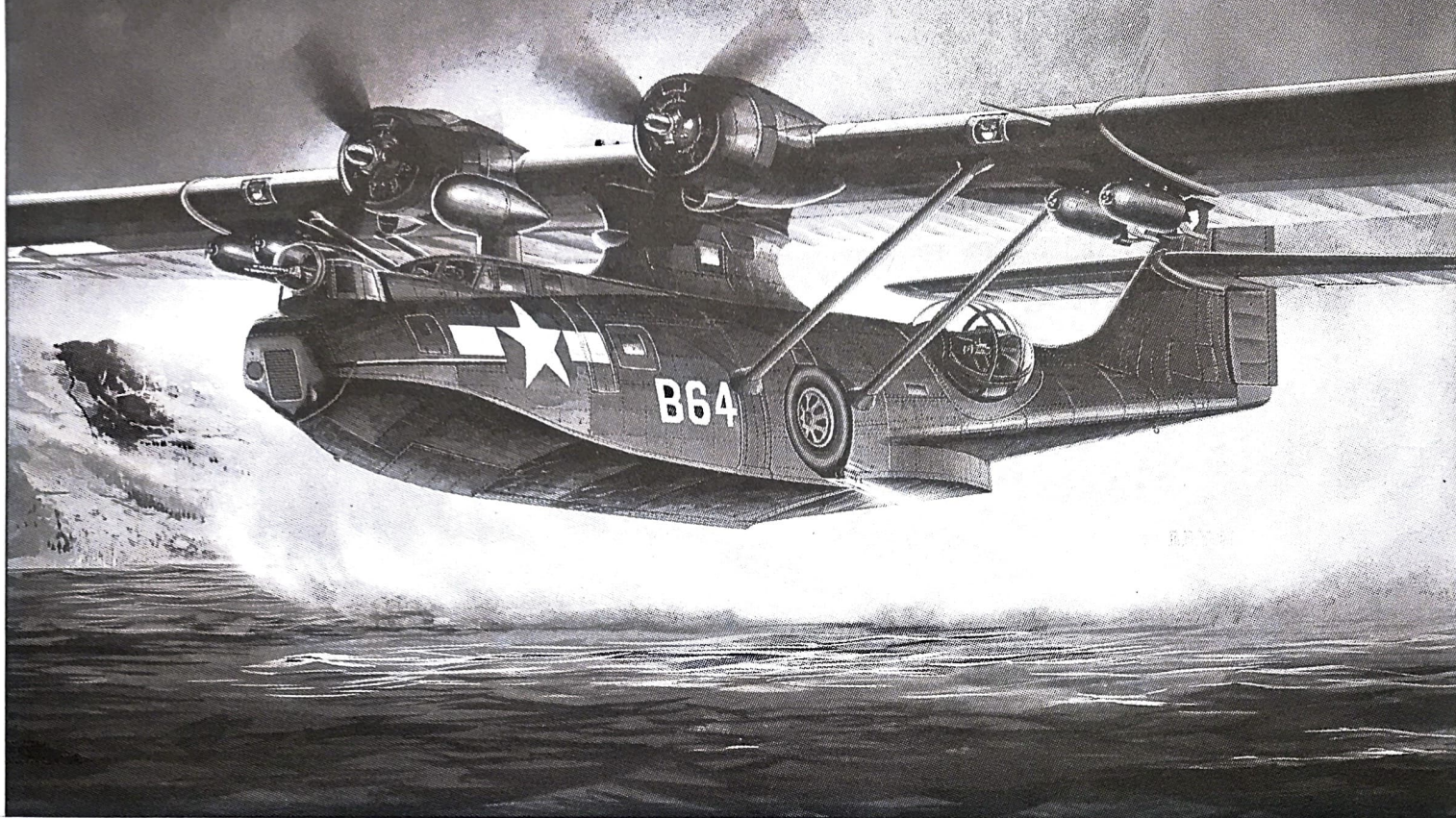

1/72 SCALE

PBY-5A BLACK CAT

The earlier PBY-2 and PBY-5 Catalina flying boats were faster and more attractive to look at, but it was the **Black Cat Squadrons** that wrote some of the most interesting chapters in the history of the War in the Pacific. Their search and attack capability was the perfect answer to the Japanese tactics of moving men and supplies at night by ship or barge to re-supply their out-of-the-way garrisons in the western Pacific.

The early RADAR installed on the PBY-5A Catalinas was crude and very limited, but it worked well enough that the **Black Cats** were able to sink over 10,000 tons and seriously damage another 24,000 tons of Japanese merchant shipping in their night attacks.

Because of its amphibian landing gear, the **PBY-5A** had the advantage of operating from island landing strips or seaplane tenders, but this came at a price. Because of the added weight of retractable landing gear, the **PBY-5A** was slower and couldn't fly as high as the earlier pure seaplane versions.

SPECIFICATIONS:

Wingspan:	104.25 feet	Length:	64.67 feet
Height:	21.25 feet	Max. Speed:	186 mph @ 6,700 feet
Service Ceiling:	15,100 feet	Range:	2,590 miles
Armament:	3 x 0.50 machine guns, 1 x 0.30 machine guns, bombs 4 x 1,000 pounds		

ENGLISH	FRENCH	GERMAN	SPANISH	ITALIAN
BLACK	NOIR	SCHWARZ	NEGRO	NERO
SILVER	ARGENT	SILBERN	PLATA	ARGENTO
GUNMETAL	METALLIC	METALLIC	METALICO	METALLICO
METALLIC	METALLIC	METALLIEK	METALICO	METALLICO
GRAY	GRIS	GRAU	GRIS	GRIGIO
YELLOW	JAUNE	GELB	AMARILLO	GIALLO
GREEN	VERT	GRÜN	VERDE	VERDE
FLAT	TERNE	GLANZLOSES	APAGADO	OPACO



Cement Parts
Coller
Kleben
Pegar
Incollare
Colar
Kleben



Do Not Cement Parts
Ne Pas Coller
Nicht Kleben
No Pegar
Non Incollare
NÃO Colar
Niet Kleben



Optional Parts
Choix
Auswahlmöglichkeit
Elección
Scelta
Opção
Keuze



Repeat Operation
Répéter l'opération
Vorgang Wiederholen
Repetir la operación
Repetir a Operação
Herhalen

1 INTERIOR ASSEMBLY

MAIN LANDING GEAR

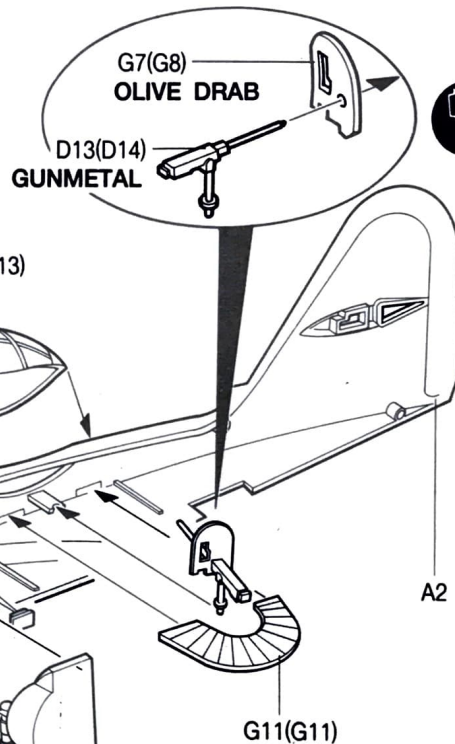
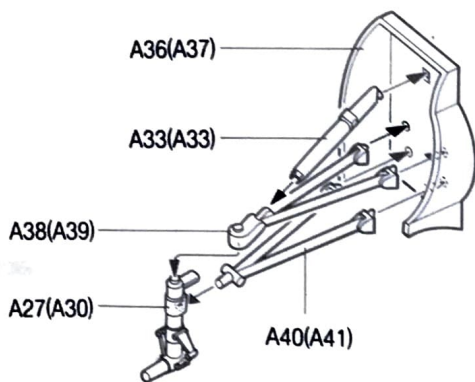

CHROMATE GREEN Interior.

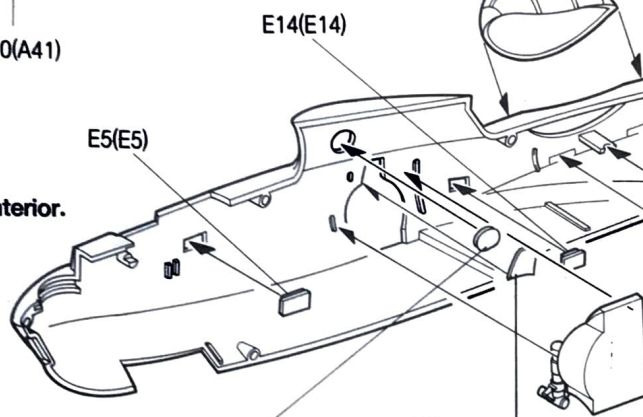

A26(A28) Use only for flying version.

INSTRUMENT PANEL

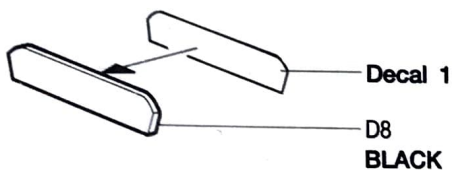

CONTROL HANDLES

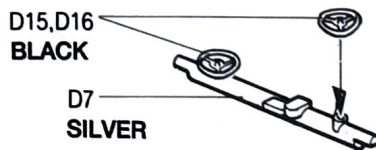

BOW TURRET

Early Version

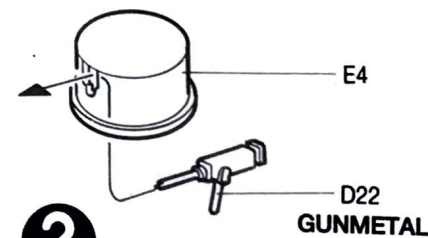

Late Version

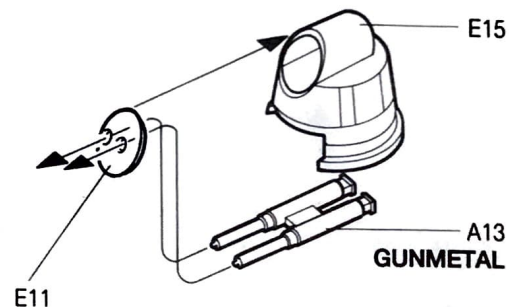

COCKPIT

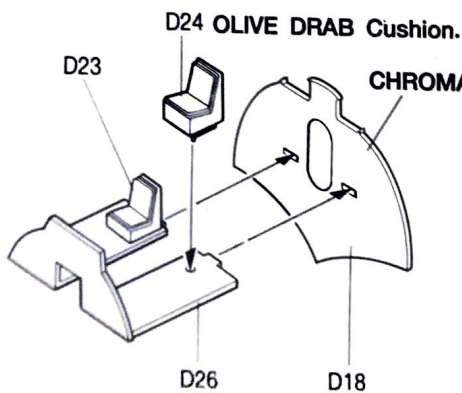

GUNNER'S POSITION

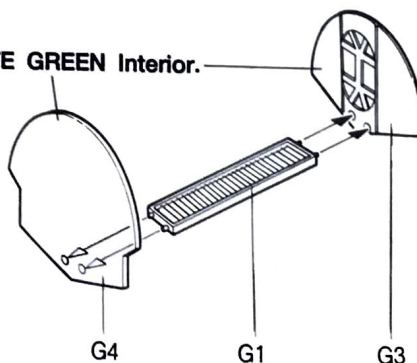

2 FUSELAGE ASSEMBLY

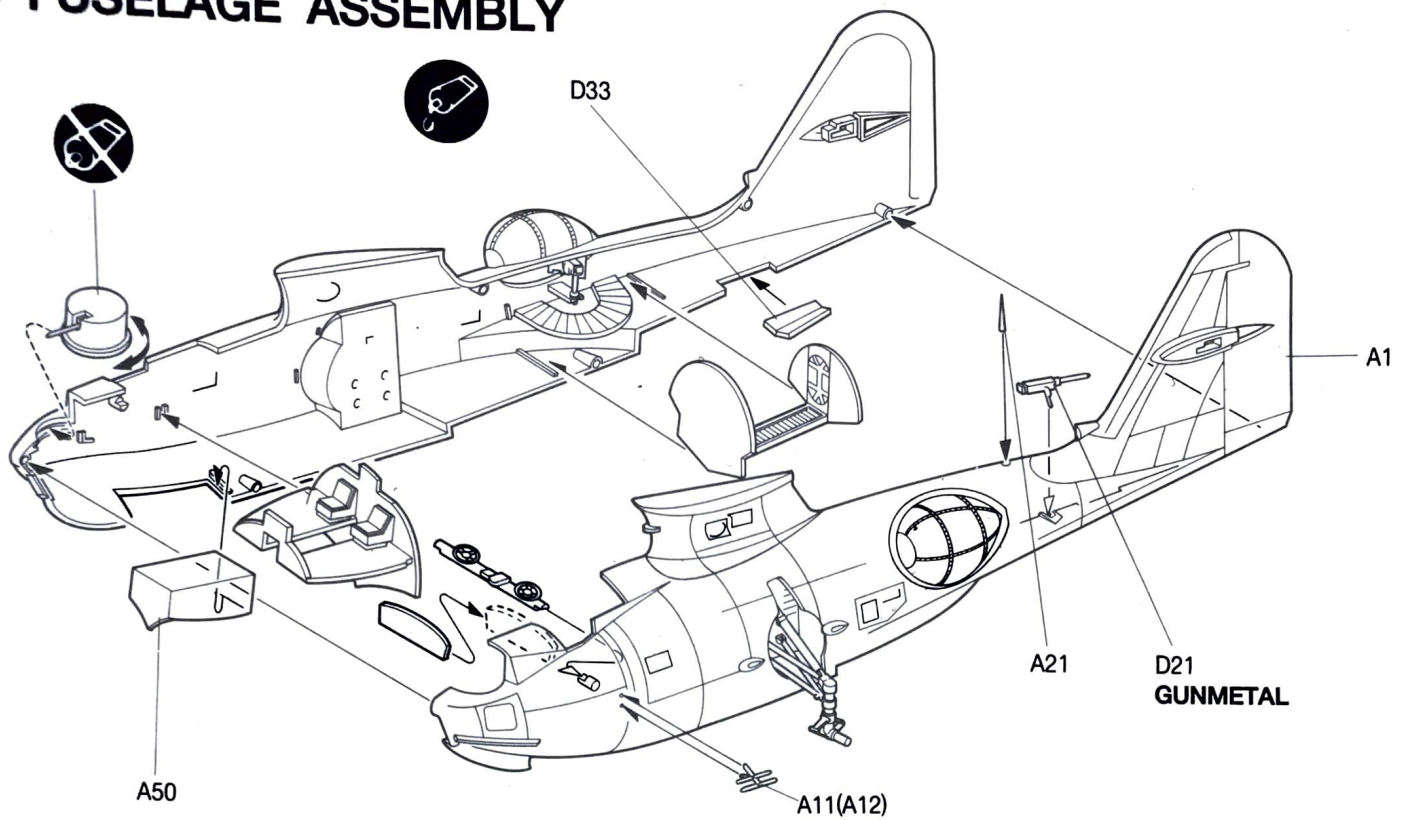

3 WING ASSEMBLY(Center)

ENGINE ASSEMBLY

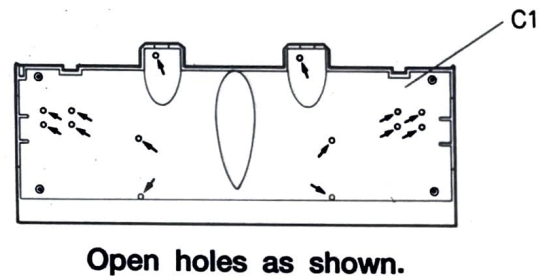
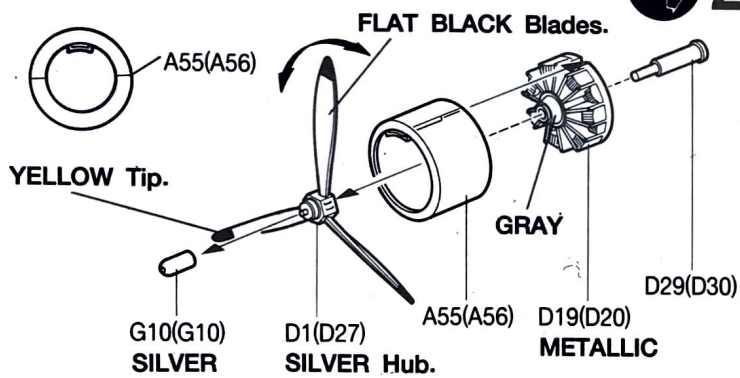

BOMB ASSEMBLY

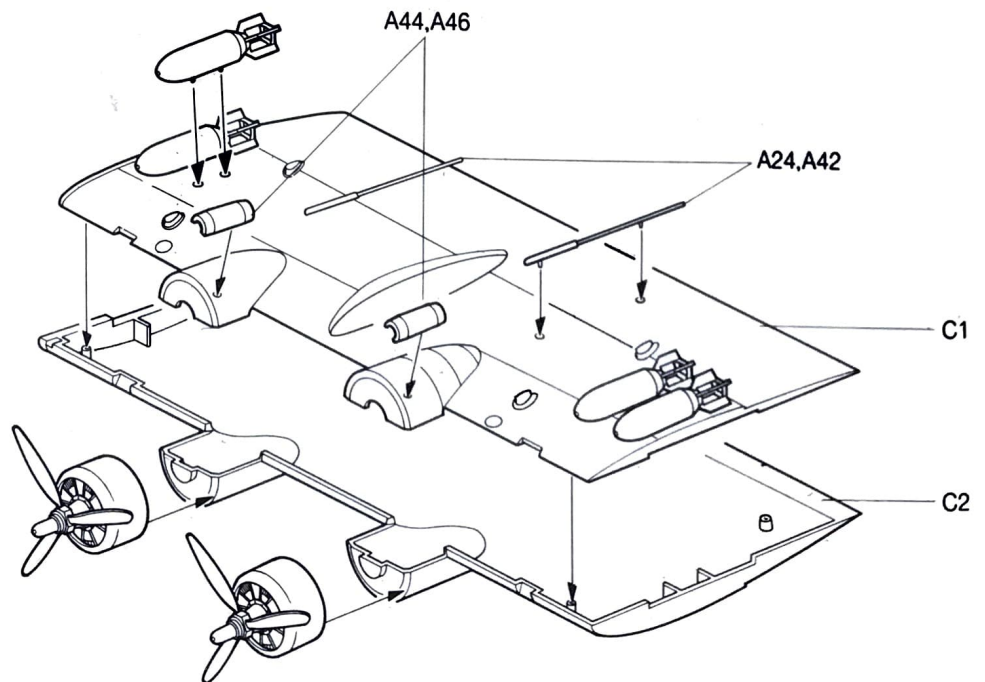
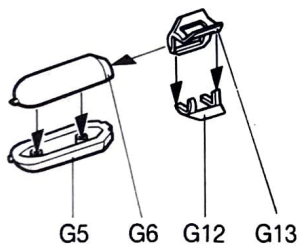

4 WING ASSEMBLY(Right & Left)

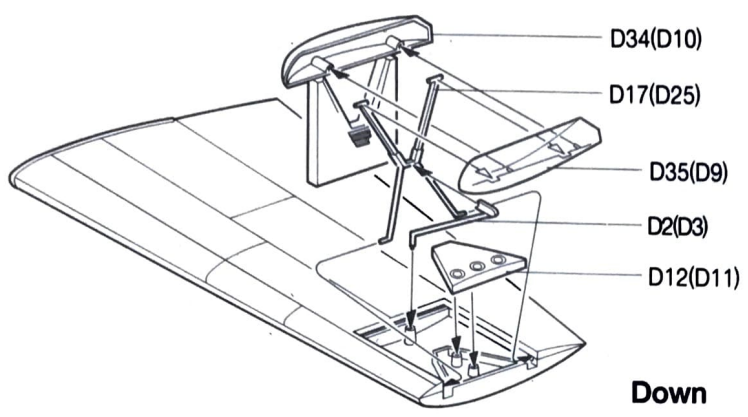

Down

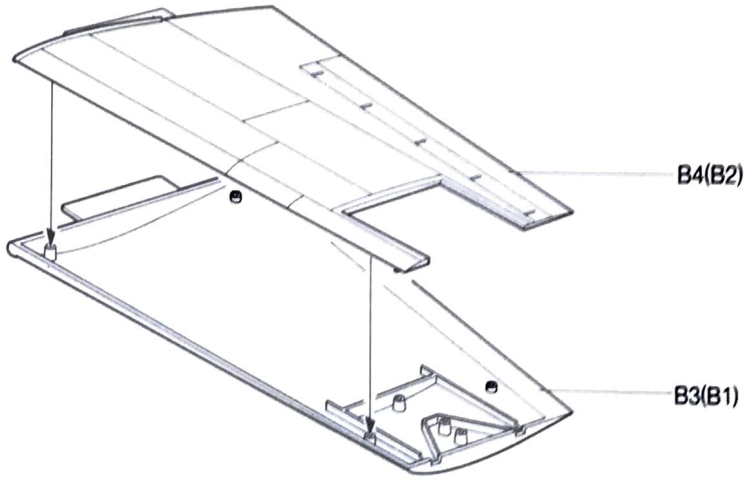

Up

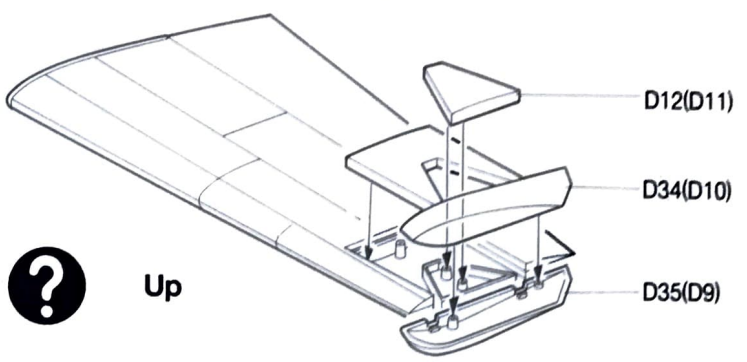

5 WING INSTALLATION

EXHAUST ASSEMBLY

Early Version



Late Version

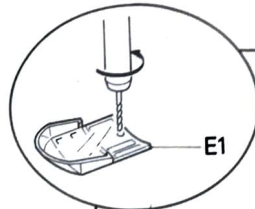
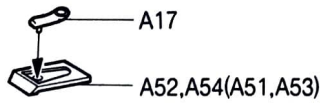

LATE VERSION

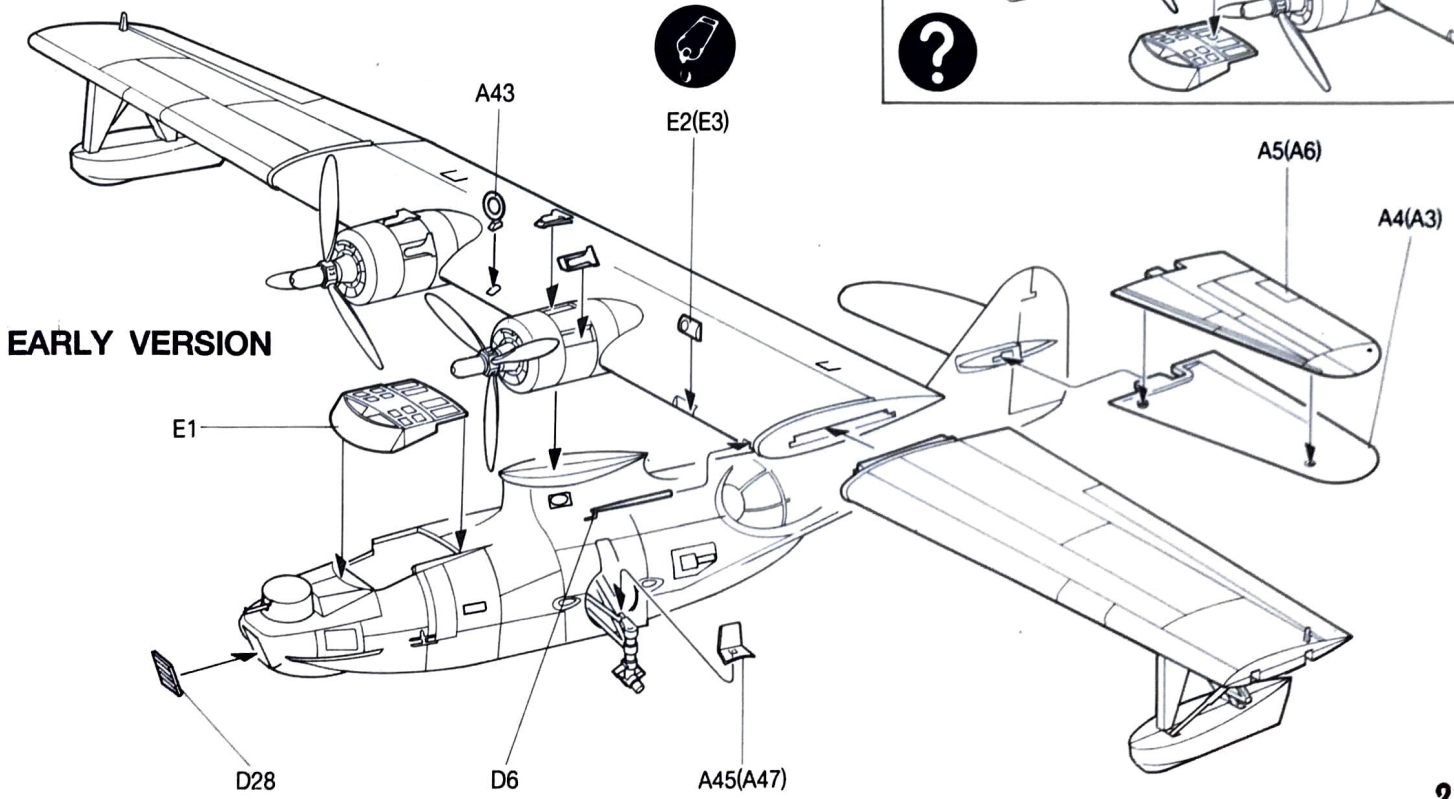
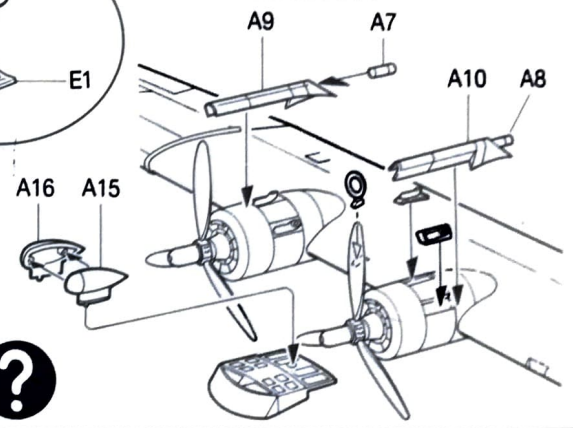

EARLY VERSION

6 FINAL ASSEMBLY

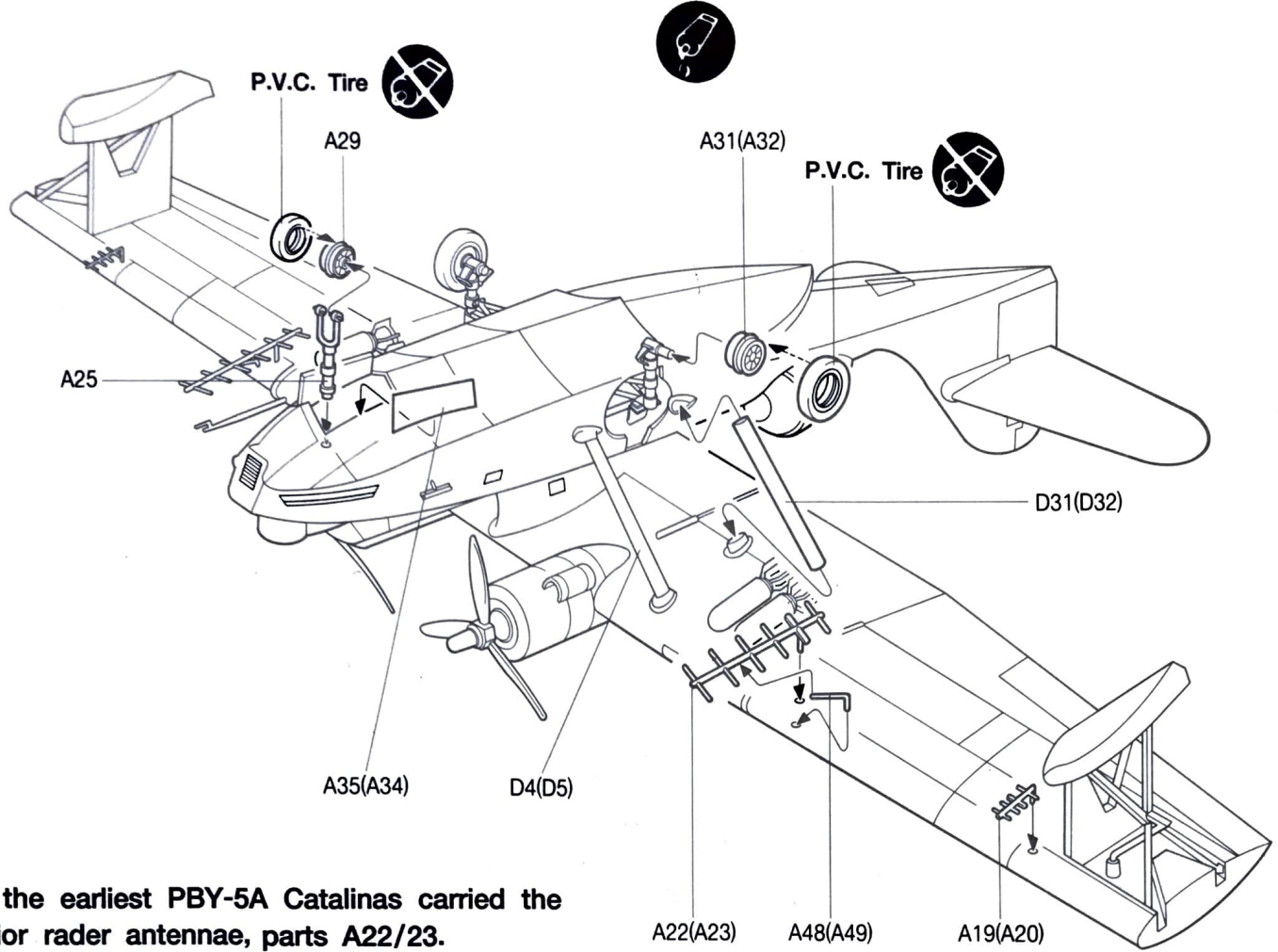

Only the earliest PB5A Catalinas carried the exterior rader antennae, parts **A22/23**.

PAINTING AND DECAL PLACEMENT

Aircraft is overall **FLAT BLACK F.S.37038**.

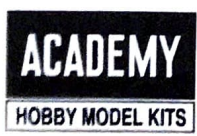
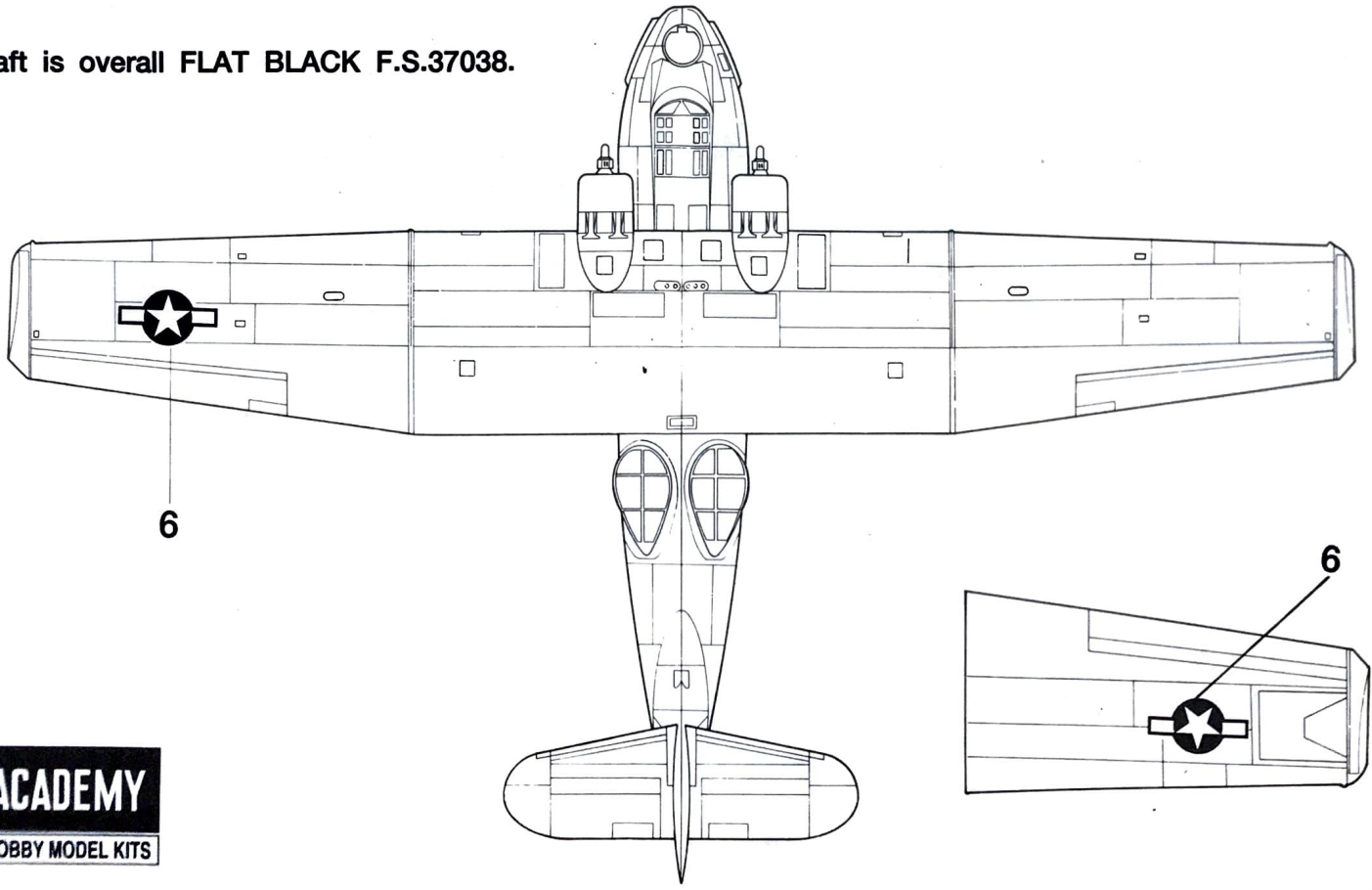

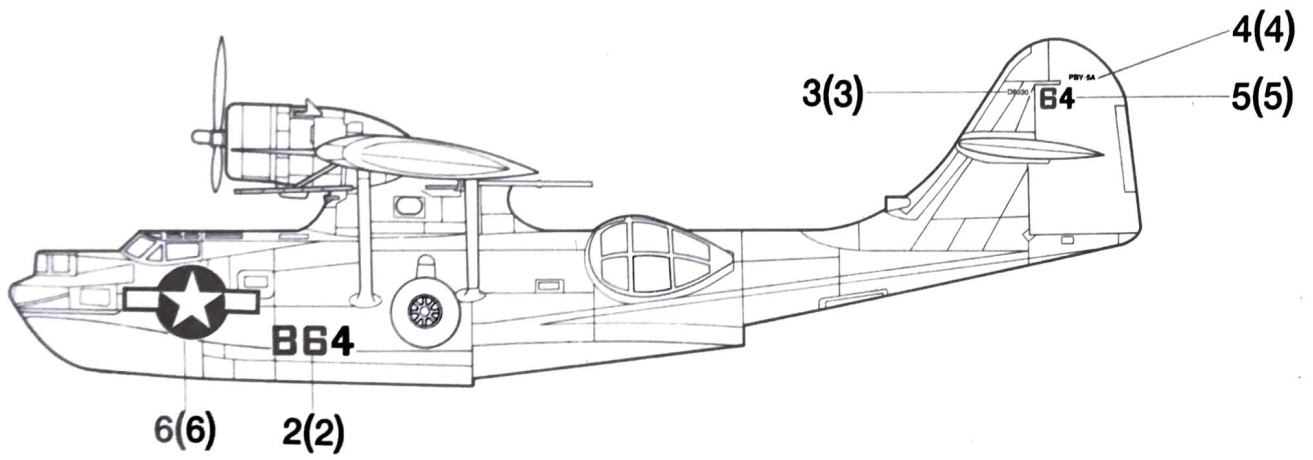

PARTS LOCATING DIAGRAM

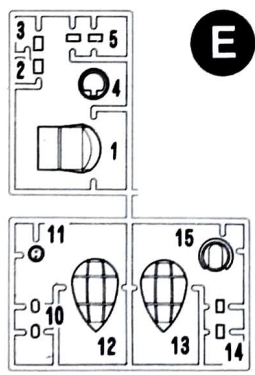
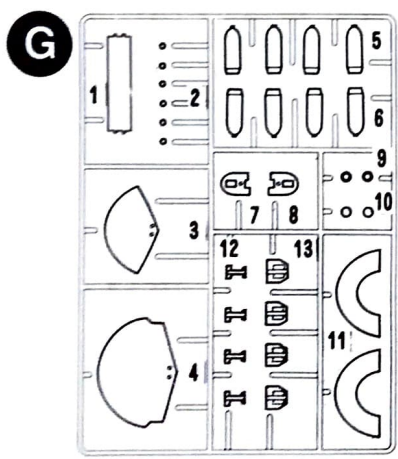
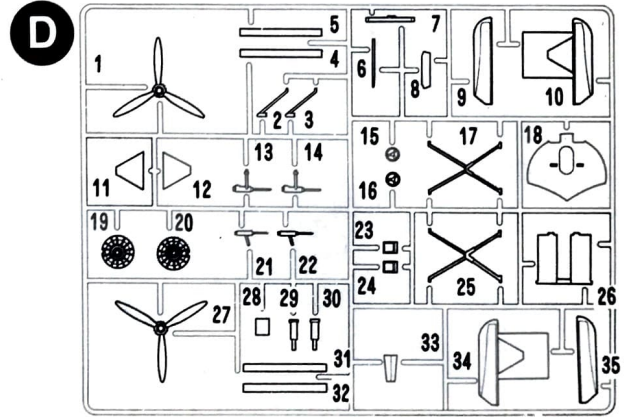
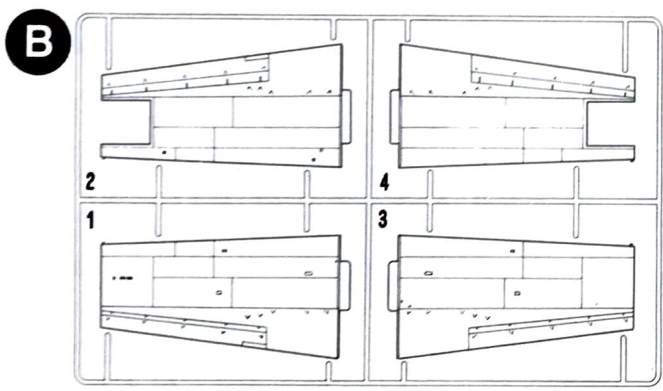
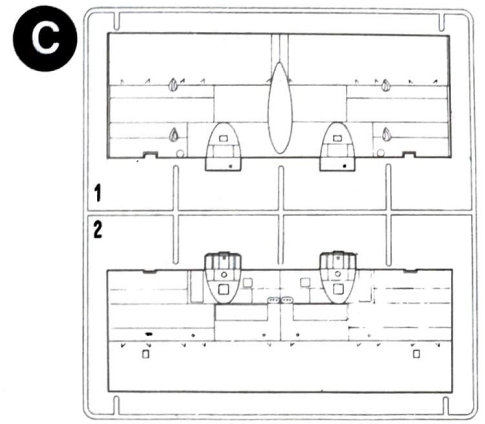
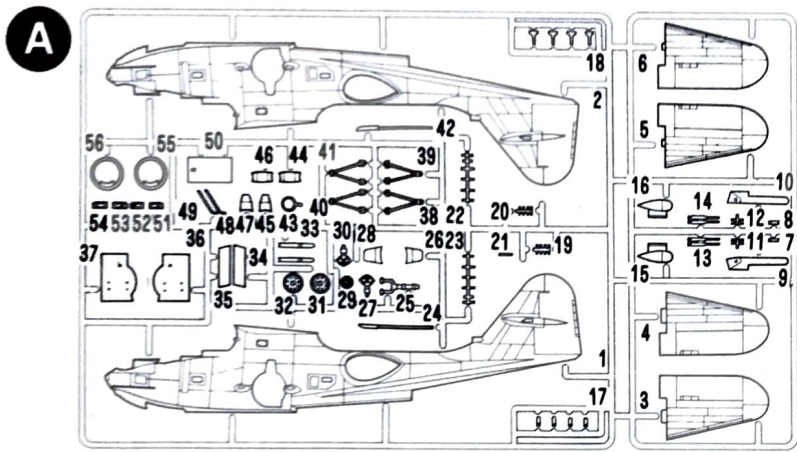

Unused parts: G2, G9, A14