



Sopwith F.1 Camel RFC

ATTENTION



UPOZORNĚNÍ



ACHTUNG



ATTENTION



注意



Carefully read instruction sheet before assembling. When you use glue or paint, do not use near open flame and use in well ventilated room. Keep out of reach of small children. Children must not be allowed to suck any part, or pull vinyl bag over the head.



Před započítím stavby si pečlivě prostudujte stavební návod. Při používání barev a lepidel pracujte v dobře větrané místnosti. Lepidla ani barvy nepoužívejte v blízkosti otevřeného ohně. Model není určen malým dětem, mohlo by dojít k požití drobných dílů.



lire soigneusement la fiche d'instructions avant d'assembler. Ne pas utiliser de colle ou de peinture à proximité d'une flamme nue, et aérer la pièce de temps en temps. Garder hors de portée des enfants en bas âge. Ne pas laisser les enfants mettre en bouche ou sucer les pièces, ou passer un sachet vinyl sur la tête.



Von dem Zusammensetzen die Bauanleitung gut durchlesen. Kleber und Farbe nicht nahe von offenem Feuer verwenden und das Fenster von Zeit zu Zeit Belüftung öffnen. Bausatz von kleinen Kindern fernhalten. Verhüten Sie, daß Kinder irgendwelche Bauteile in den Mund nehmen oder Plastiktüten über den Kopf ziehen.



組み立てる前に必ず説明書をお読み下さい。接着剤や塗料をご使用の際は、窓を開けて十分な換気をおこない、火のそばでは使用しないで下さい。小さな子供の手の届かない所に必ず保管してください。部品や破片を噛んだり、なめたり、飲んだりすると大変危険です。又、部品を取り出した後のビニール袋は、小さな子供が頭から被ったりすると窒息する恐れがありますので、破り捨てて下さい。

INSTRUKTION SIGNS



INSTR. SYMBOLY



INSTRUKTION SINNBILDEN



SYMBOLES



記号の説明



OPTIONAL
FACULTATIF
NACH BELIEBEN
VOLBA
選択する



BEND
PLIER SIL VOUS PLAIT
BITTE BIEGEN
OHNOUT
折る



OPEN HOLE
FAIRE UN TROU
OFFNEN
VYVRTAT OTVOR
穴を開ける



SYMETRICAL ASSEMBLY
MONTAGE SYMÉTRIQUE
SYMMETRISCHE AUFBAU
SYMETRICKÁ MONTÁŽ
左右均等に組み立てる



NOTCH
L INCISION
DER EINSCHNITT
ZÁŘEZ
切る



REMOVE
RETIRER
ENTFERNEN
ODŘÍZNOUT
移す



APPLY EXPRESS MASK
AND PAINT BEFORE
GLUING
POUŽÍT EXPRESS MASK
NABARVIT PŘED SLEPENÍM



GUNZE			APPROXIMATE COLOR MATCH			
AQUEOUS	Mr.COLOR		TAMIYA	HUMBROL	REVELL	TESTORS
H 12	33	BLACK / SCHWARTZ / NOIR / ČERNÁ	XF 2	34	5	1768
H 13	3	RED / ROT / ROUGE / ČERVENÁ	XF 9	73		
H 25	34	BLUE / BLAU / BLEU / MODRÁ	X 14	48		
H 37	43	WOOD BROWN / HOLZ / BOIS / DŘEVO	XF 55	110	88	2021
H 53	13	GREY / GRAU / GRIS / ŠEDÁ		128	374	1741
H 84	42	BROWN / BRAUN / BRUN / HNĚDÁ	XF 10	98		
H 85	45	CLEAR DOPED LINEN / LINNEN / TOILE / PLÁTNO		71	314	
H 309	309	GREEN / GRÜN / VERT / ZELENÁ	XF 13	116		1710
H 338	338	GRAY / GRAU / GRIS / ŠEDÁ		32	9	1788
Mr.METAL COLOR						
MC211		CHROM SILVER / CHROMSILBER / CROMÉ / CHROM	X 11	11	90	1290
MC213		STEEL / STAHL / ACIER / OCEL	XF 16			1424
MC214		DARK IRON / DUNKEL EISEN / KOV. ČERNÁ	X 10	53		1795
MC215		COPPER / KUPFER / CUIVRE / MĚĎ	XF 6	12	93	
MC218		ALUMINIUM / ALUMINIUM / ALUMINIUM / HLINÍK	XF 56	56	99	1781



<A>

PLASTIC PARTS

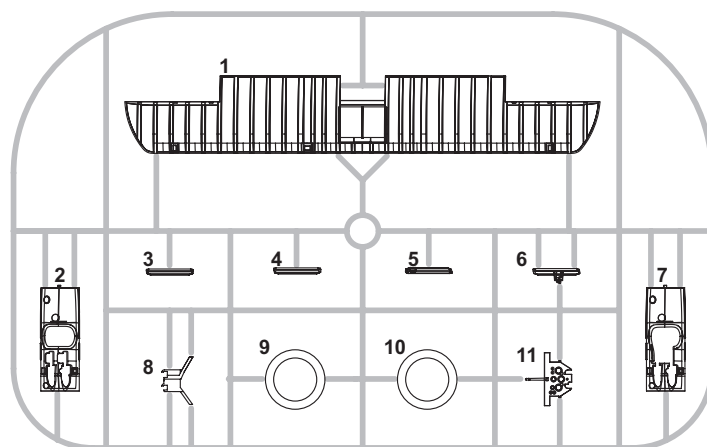
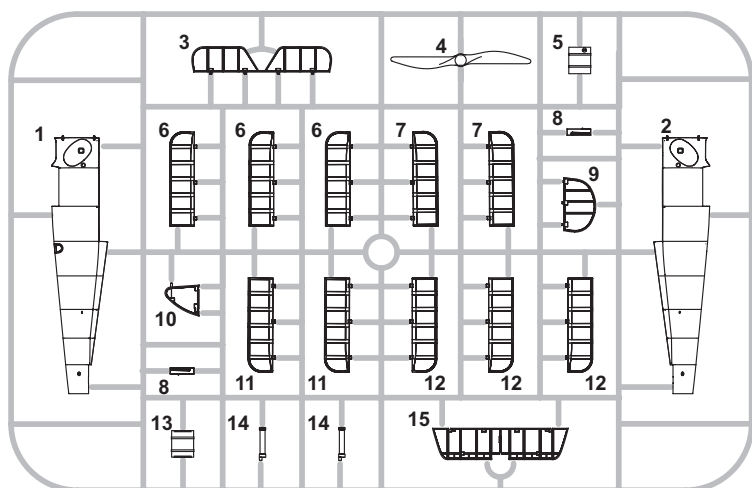

<C>

<D>

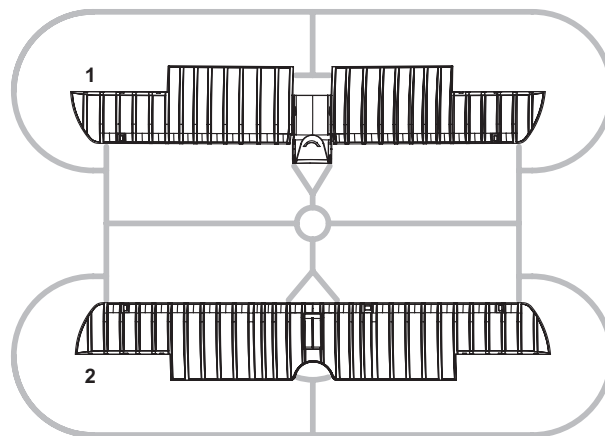
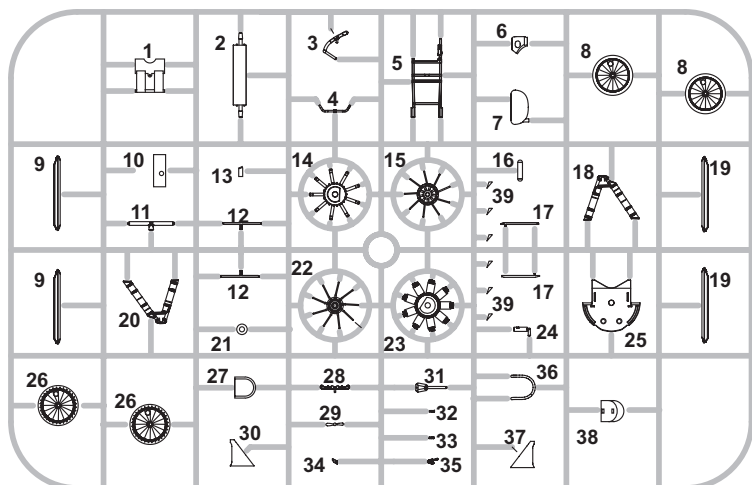

PE - PHOTO ETCHED DETAIL PARTS

<F>

eduard
Express Mask

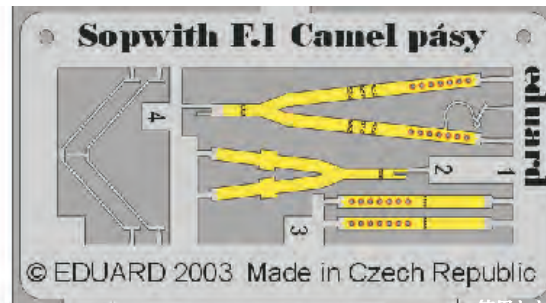
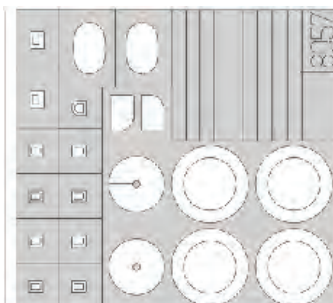
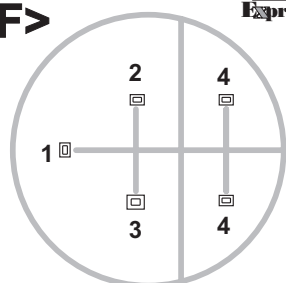

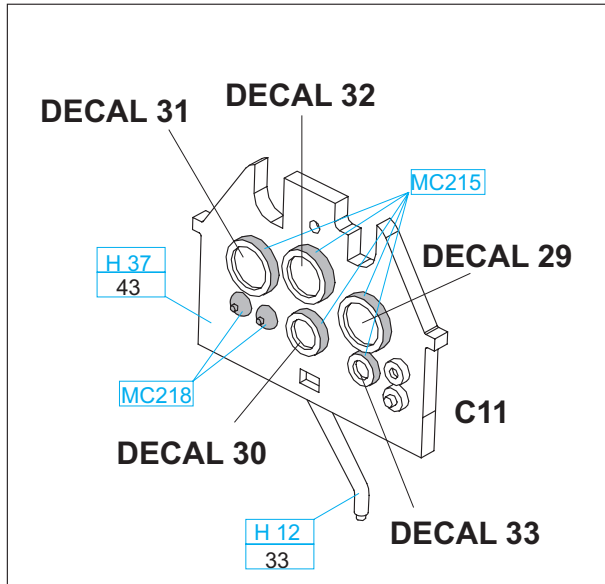
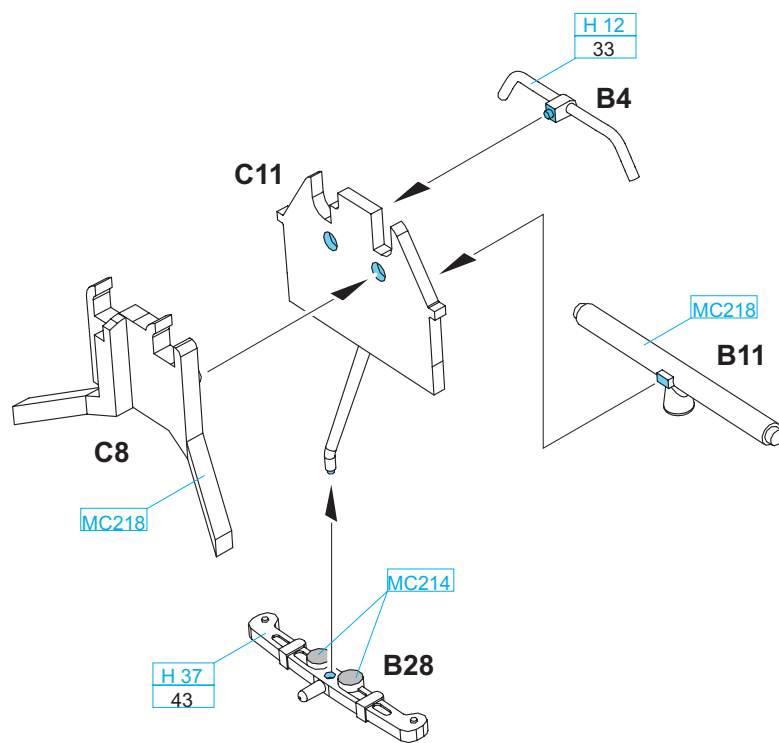
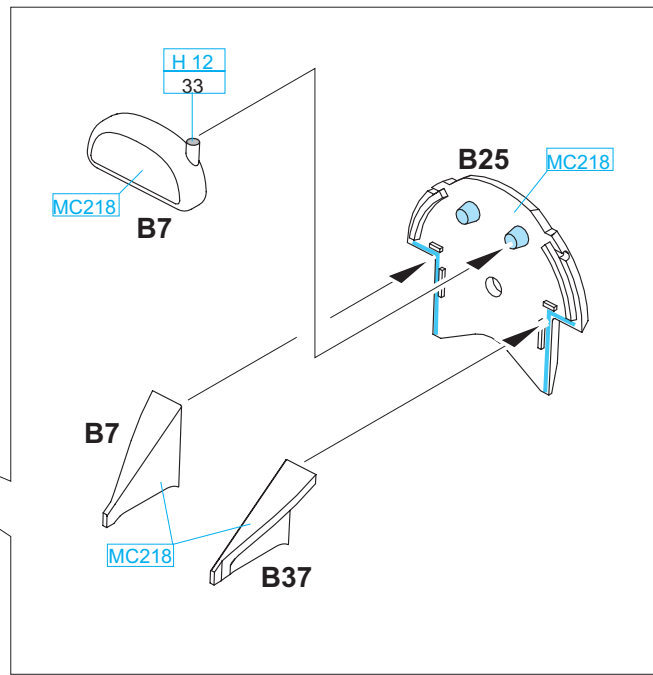
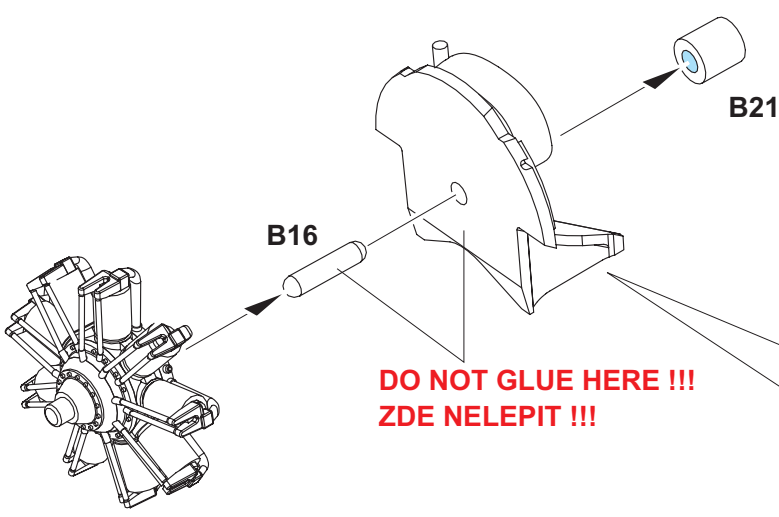
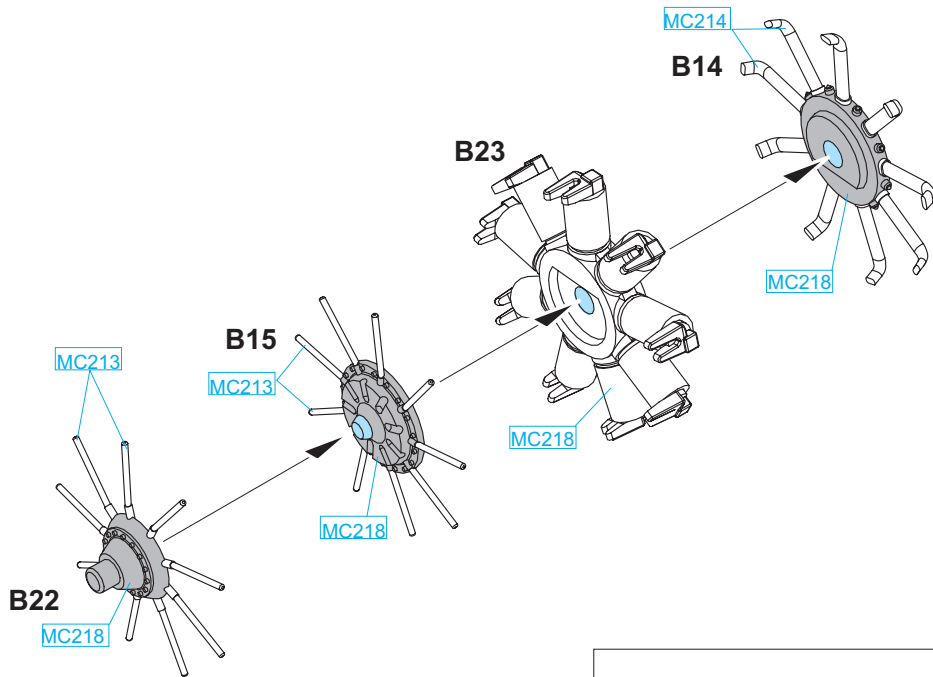

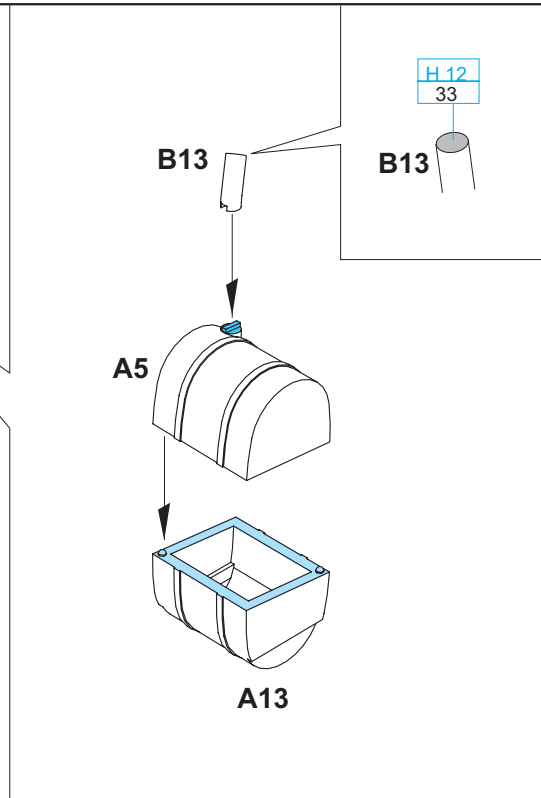
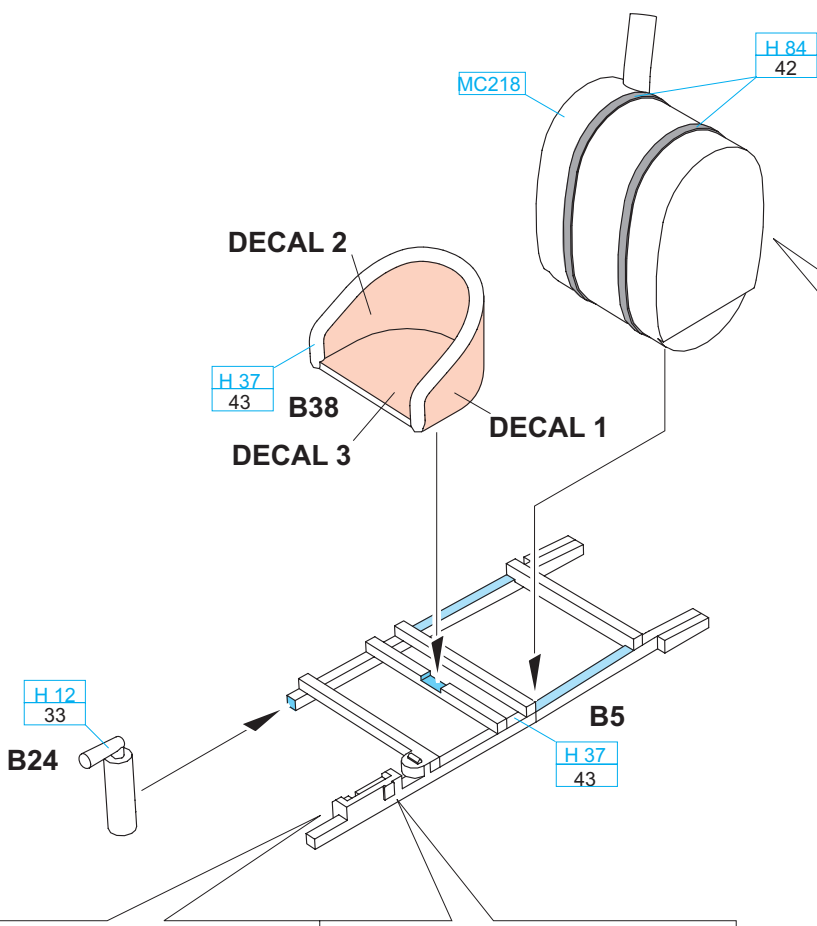

DECAL

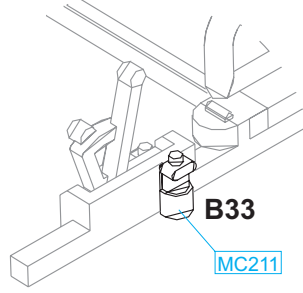
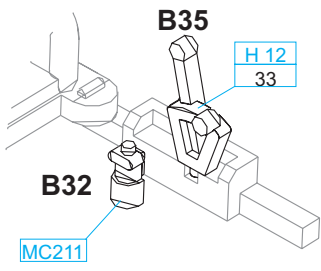
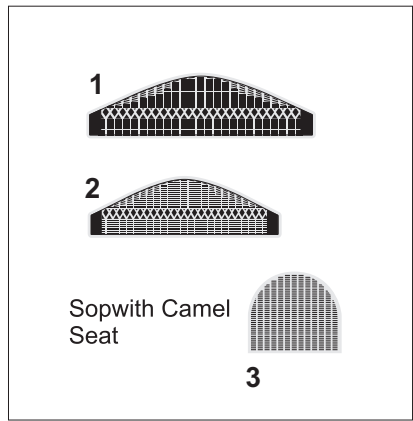

2

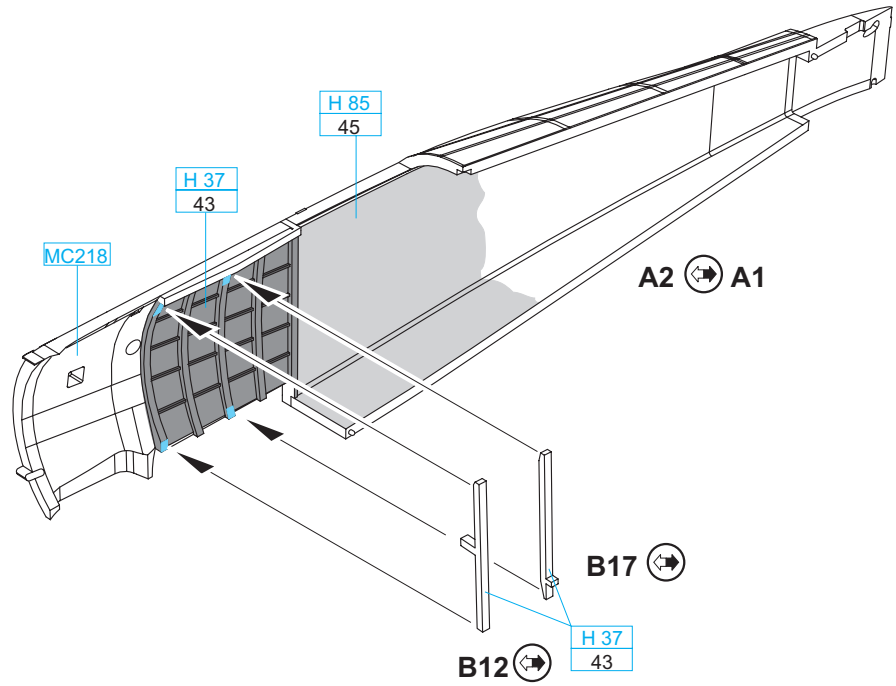

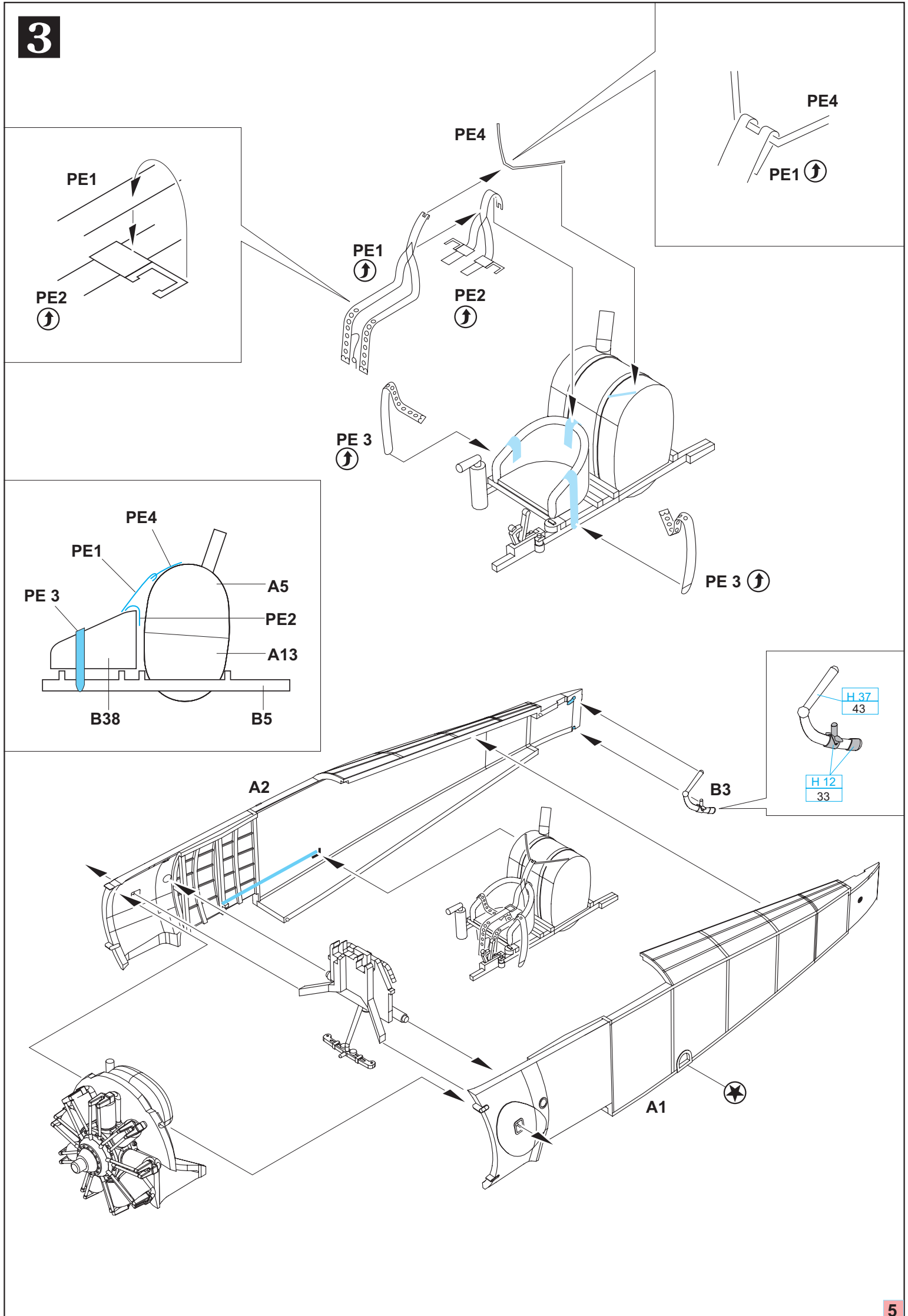

4

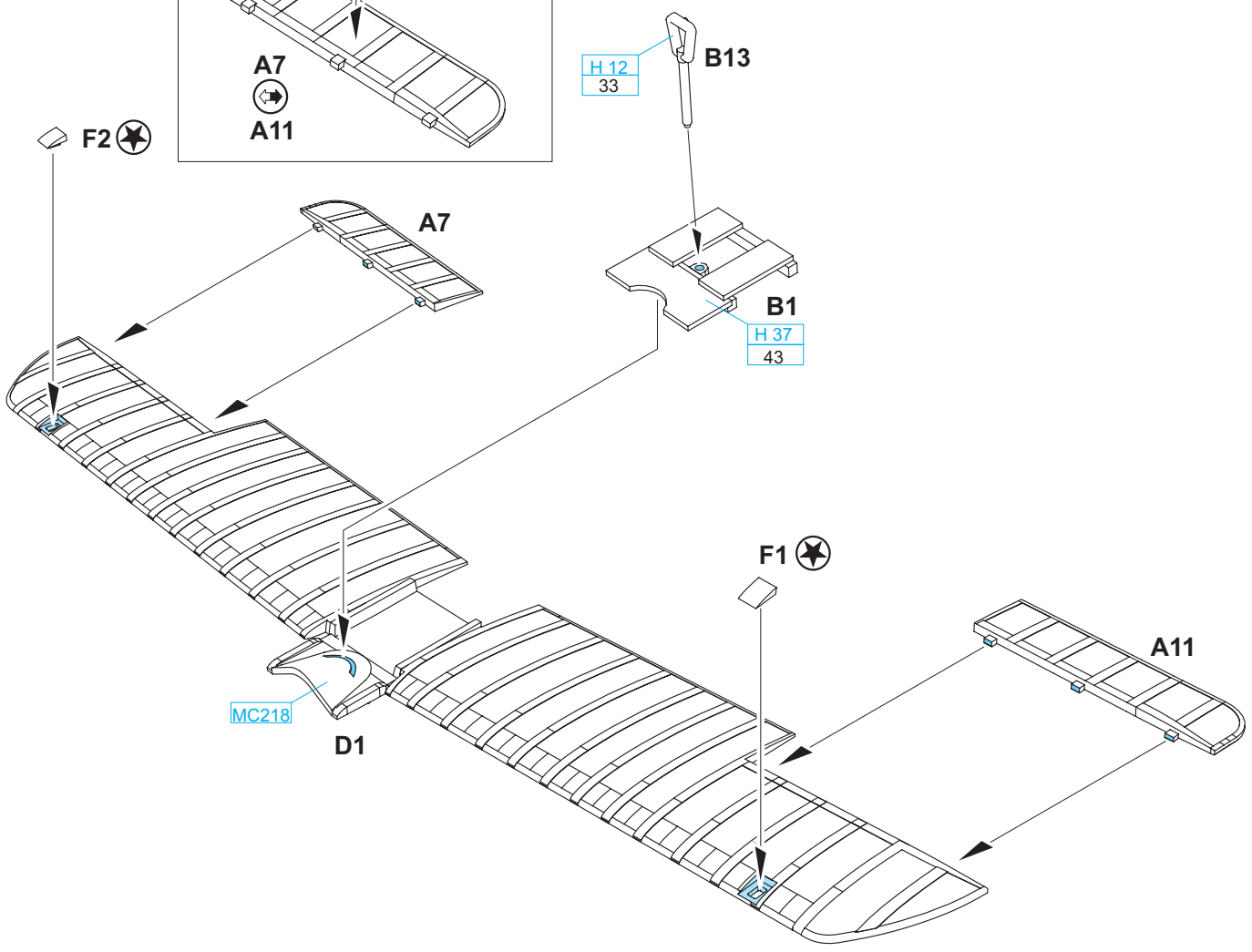
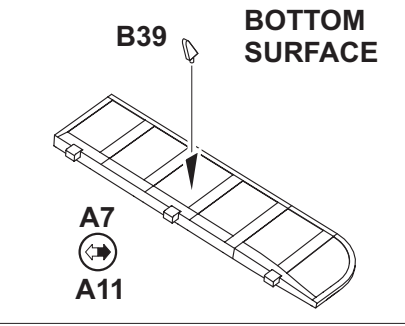

5

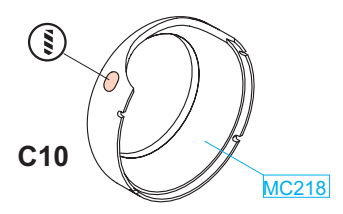
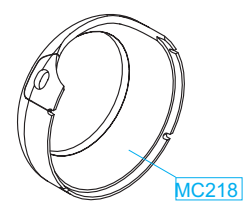
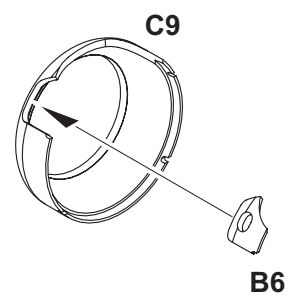
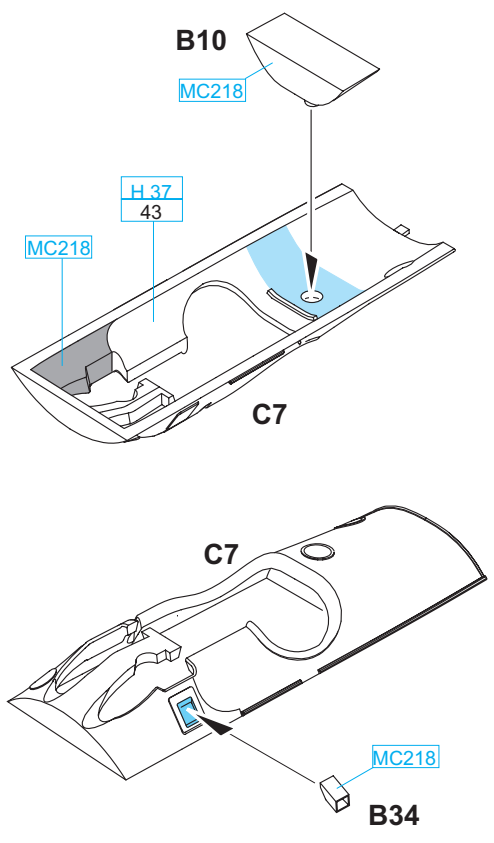

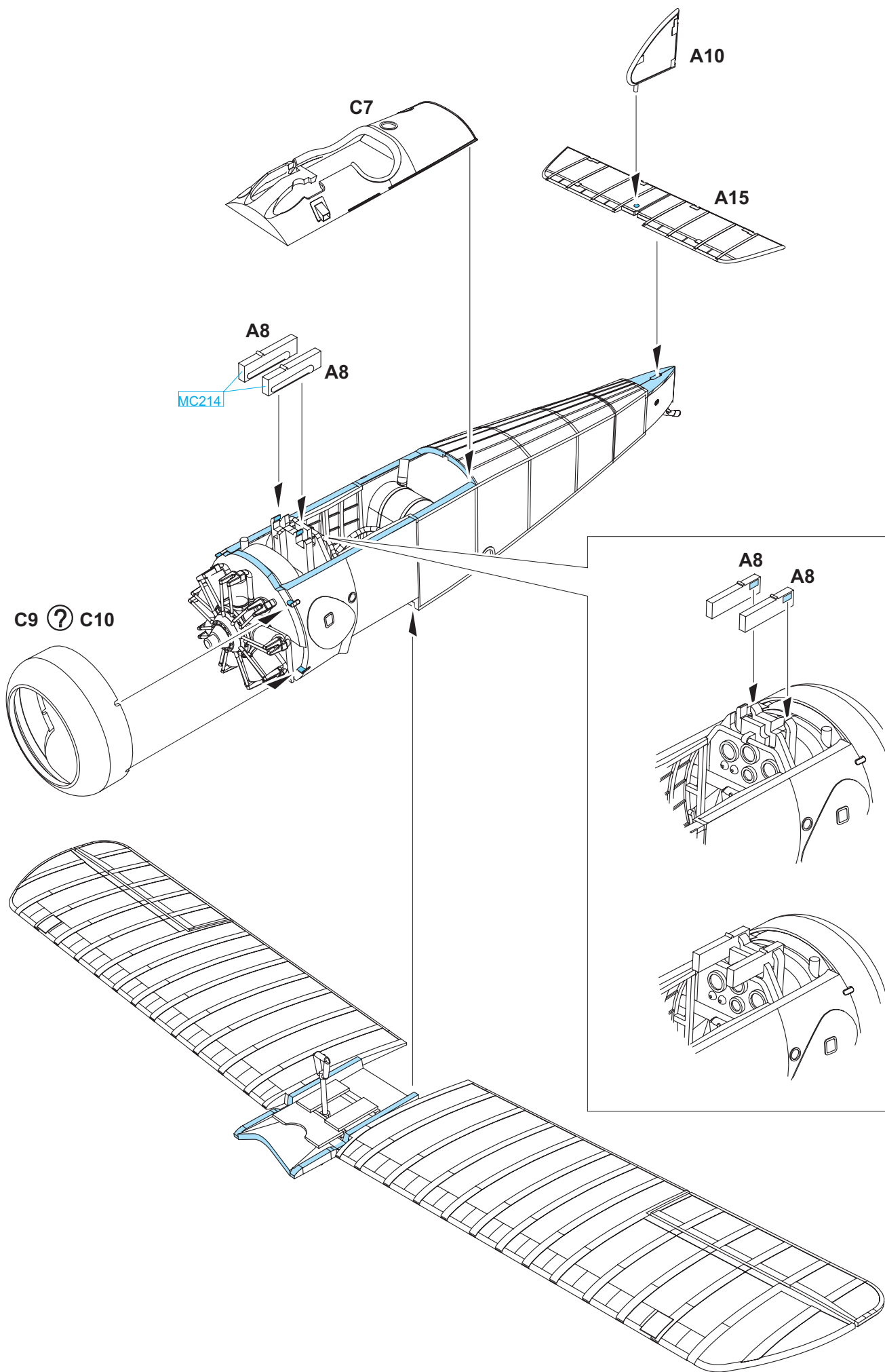

7

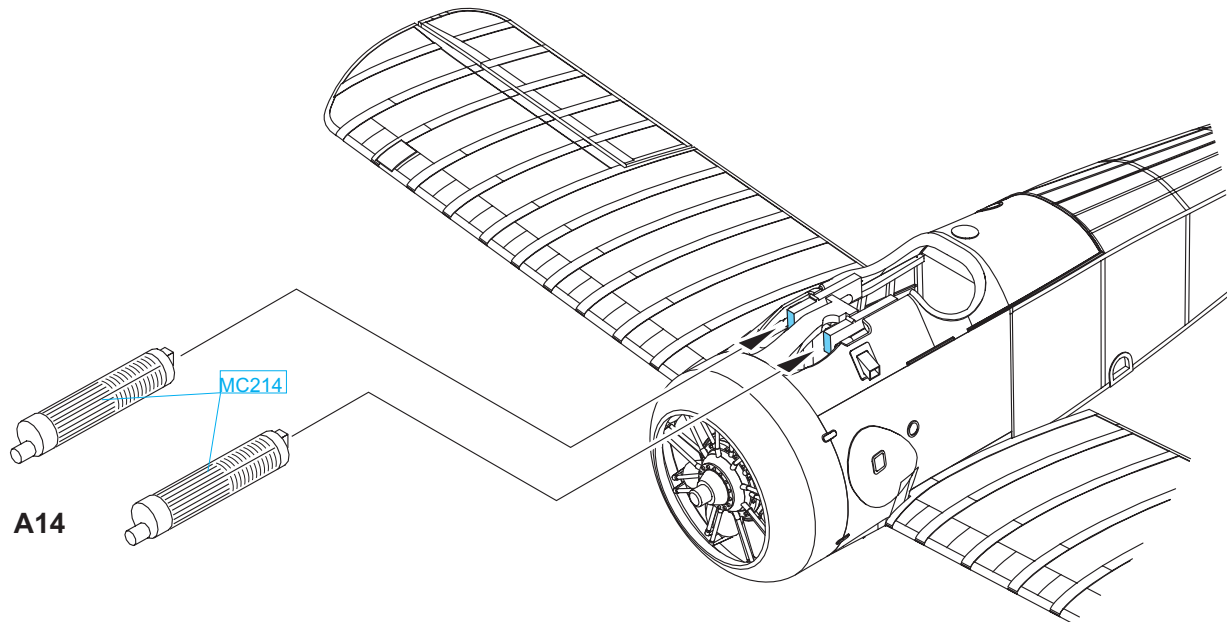

8

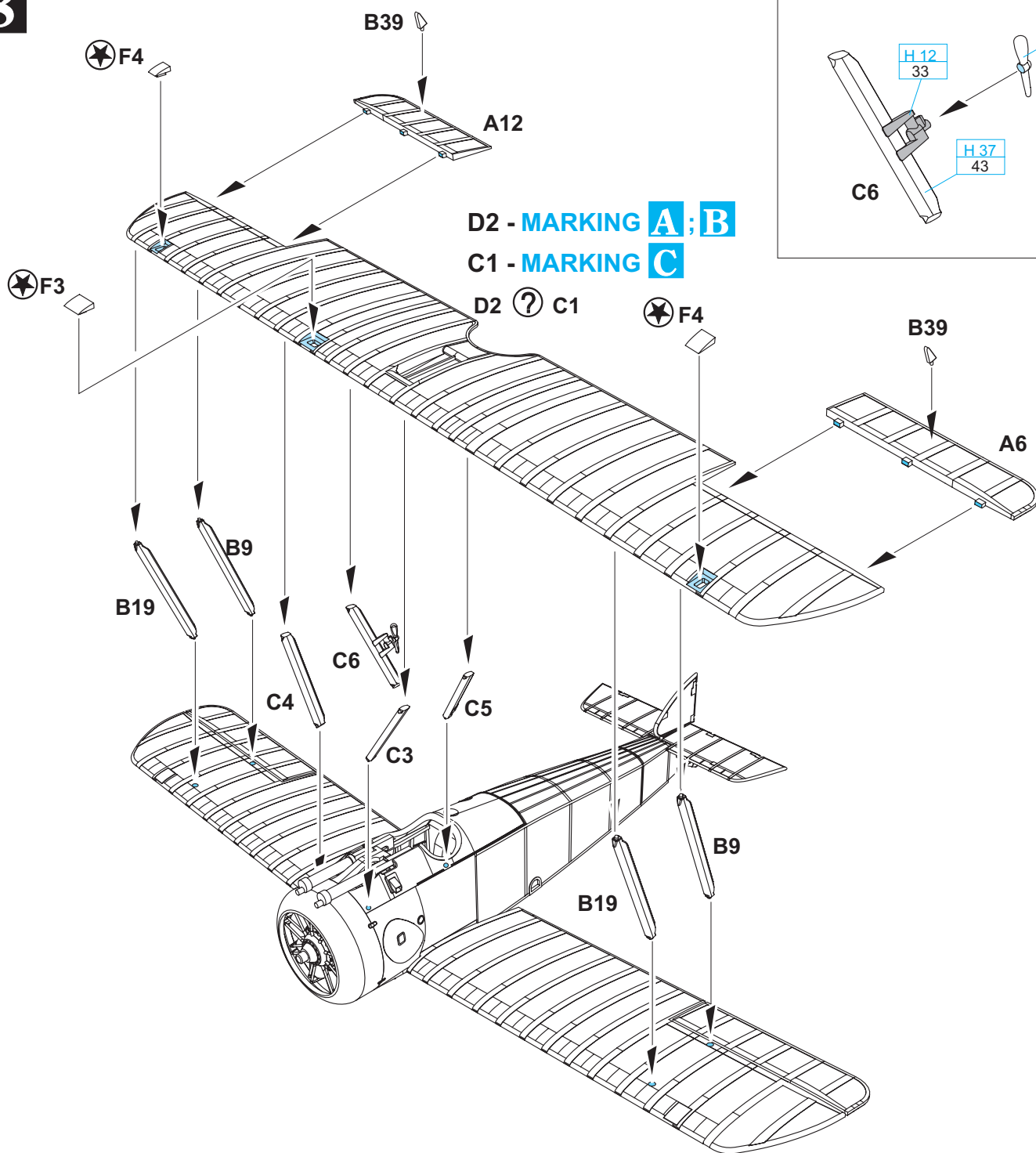

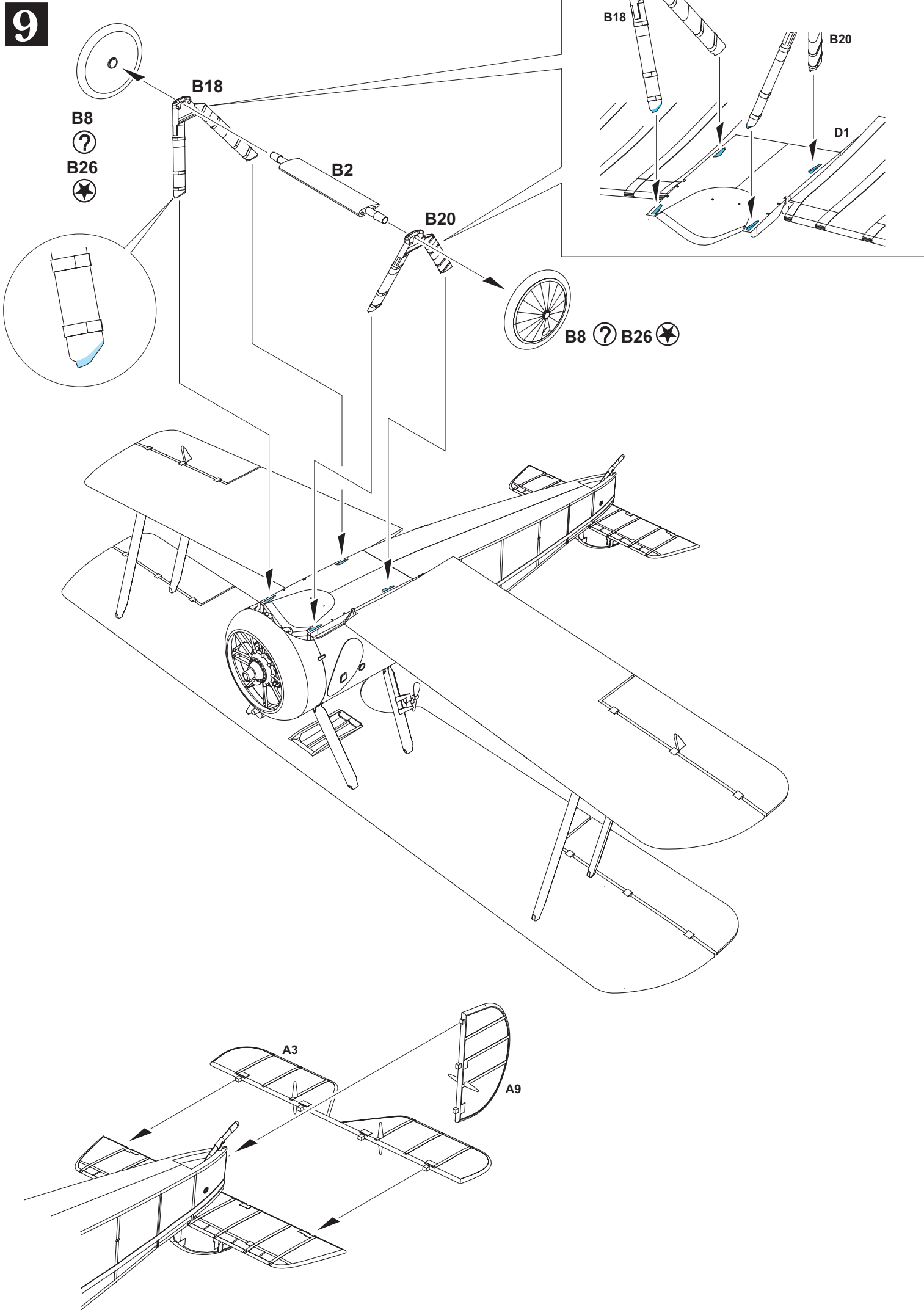

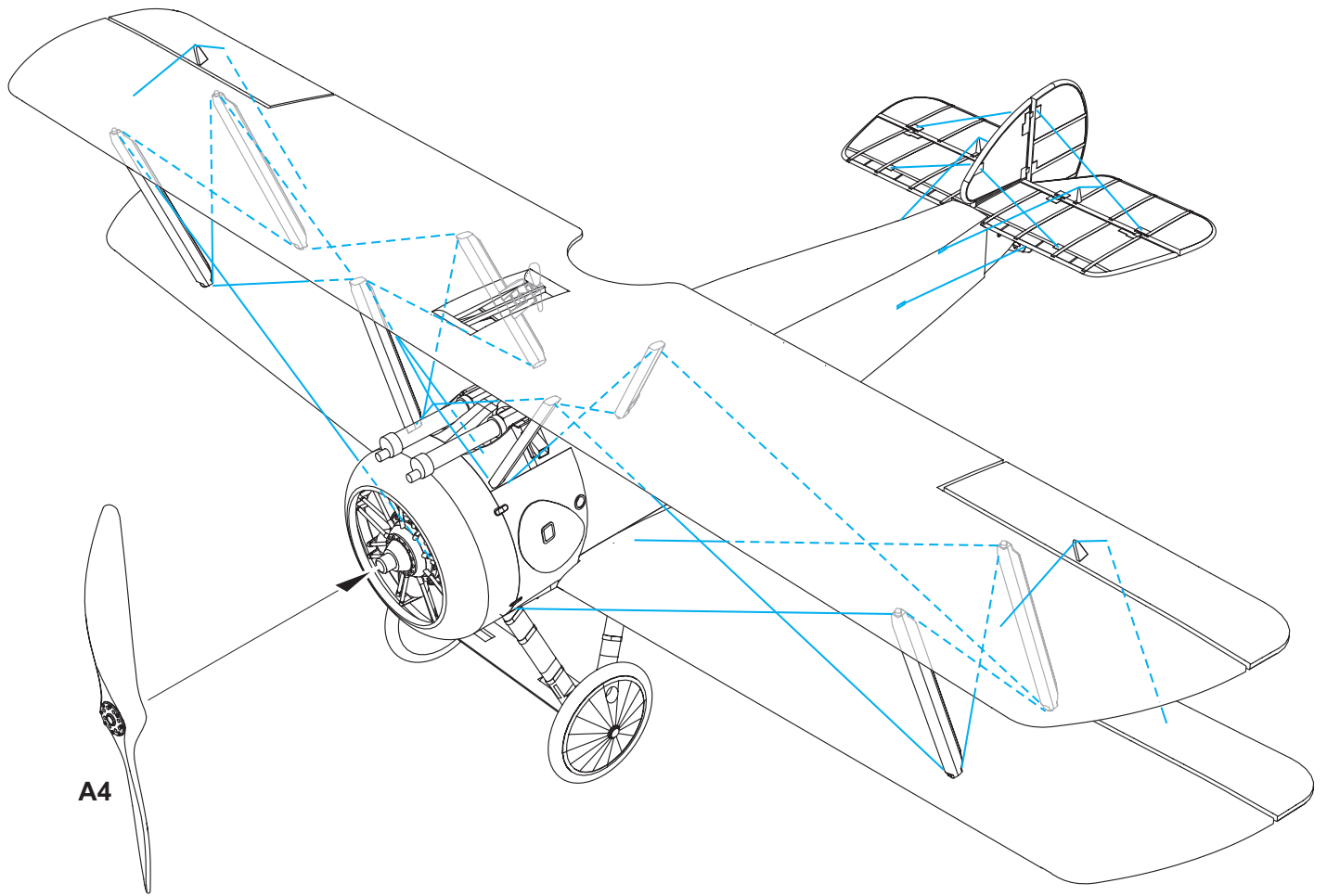
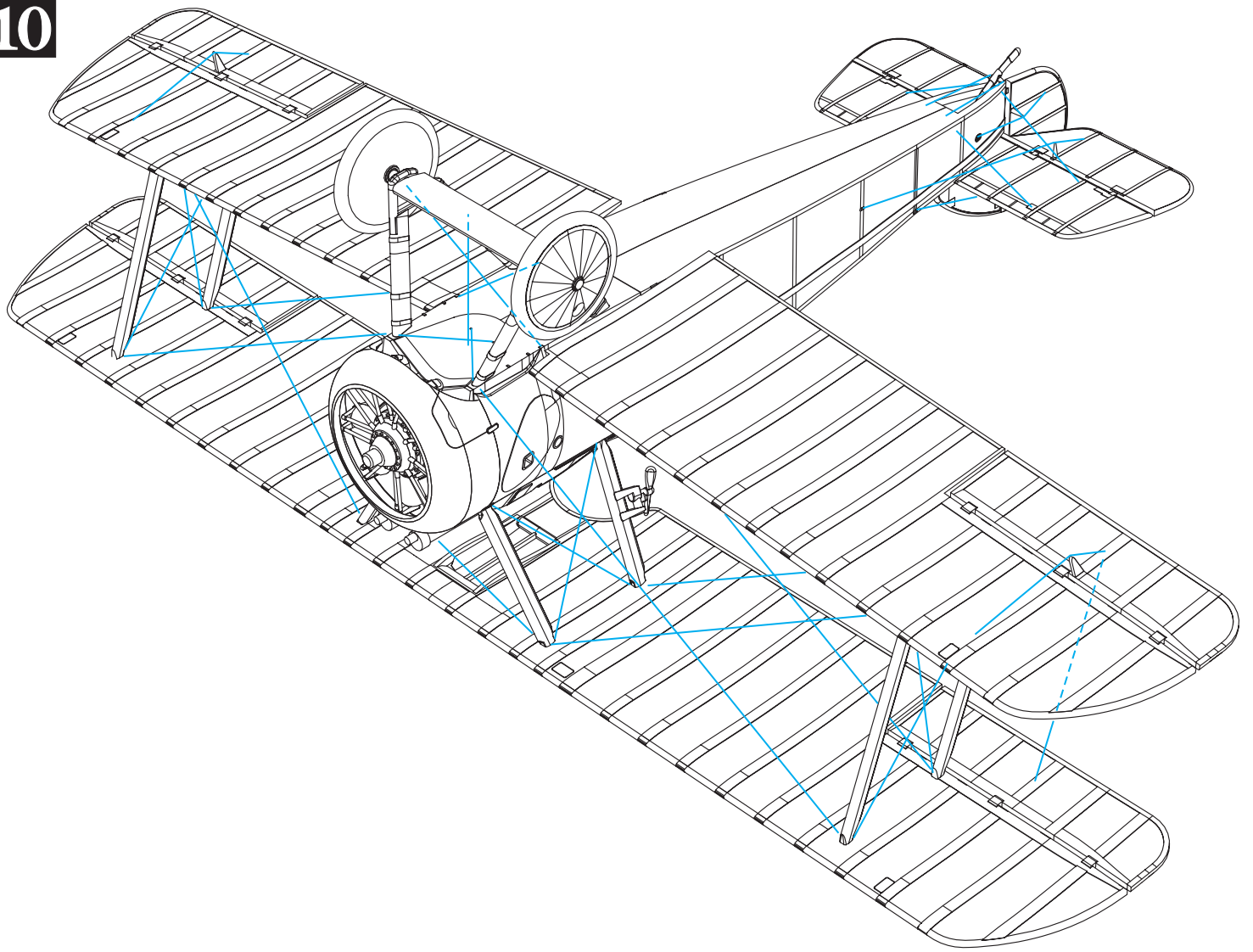

A4

8057

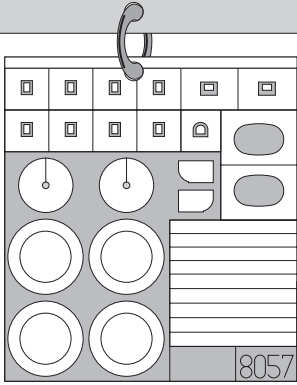

2 pcs. B8 (?) B26

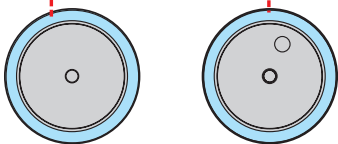
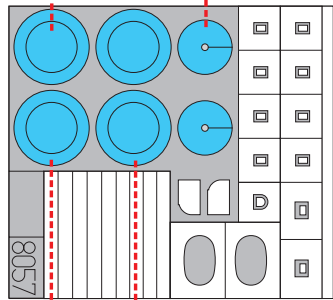
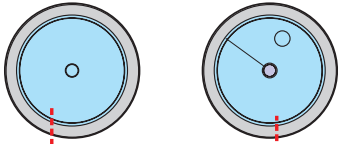

2 pcs. B8 (?) B26

MARKING A

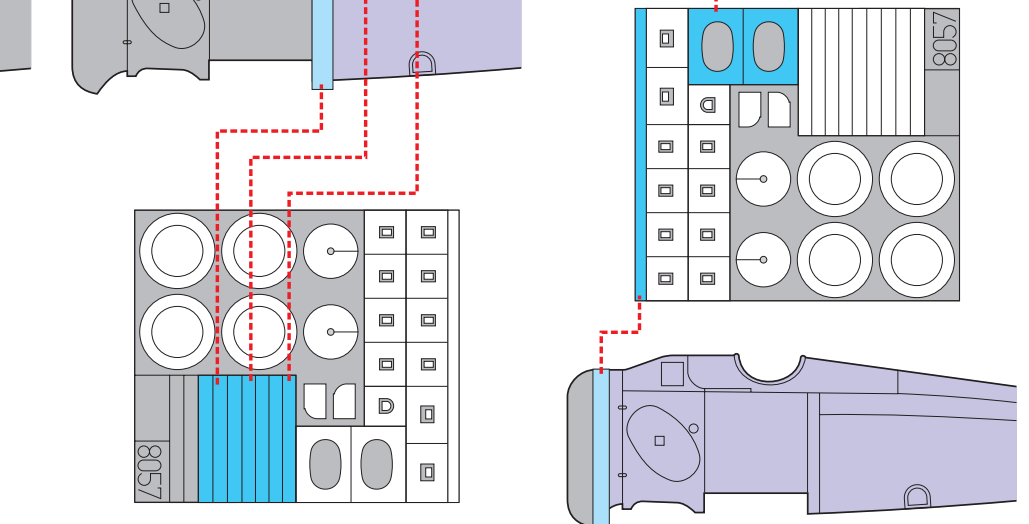
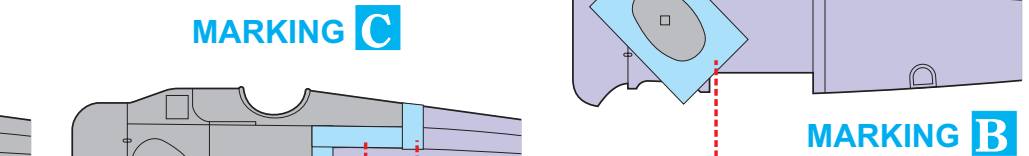
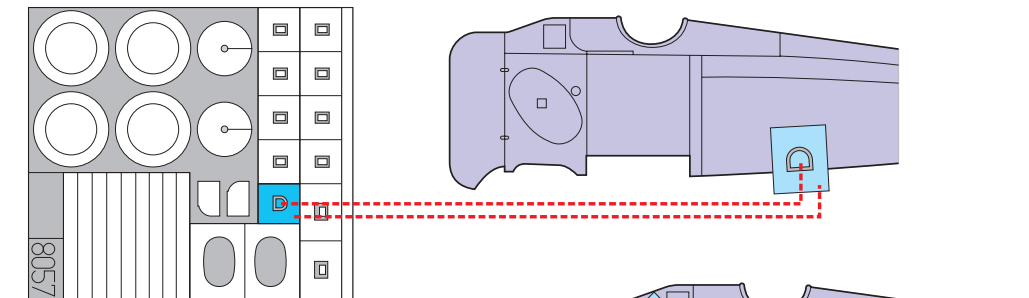
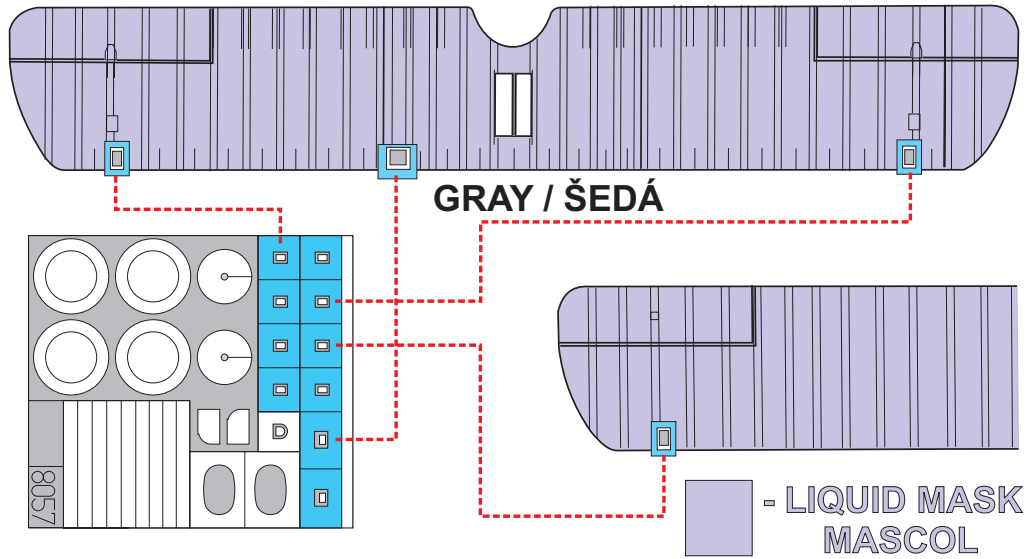
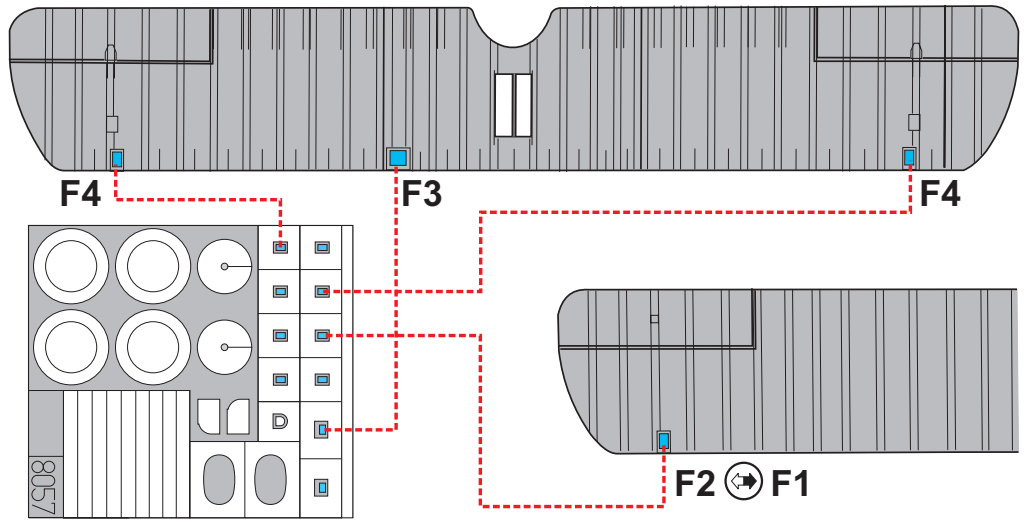
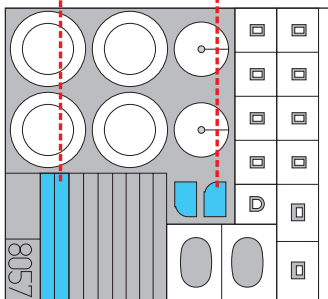
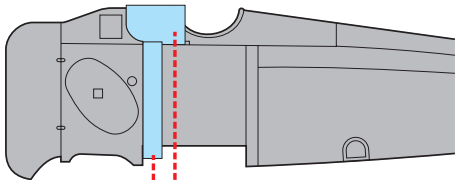

A Sopwith Camel F.1 B7270, Capt Roy Brown, No 209 Sqn, Bertangles, France, April 1918

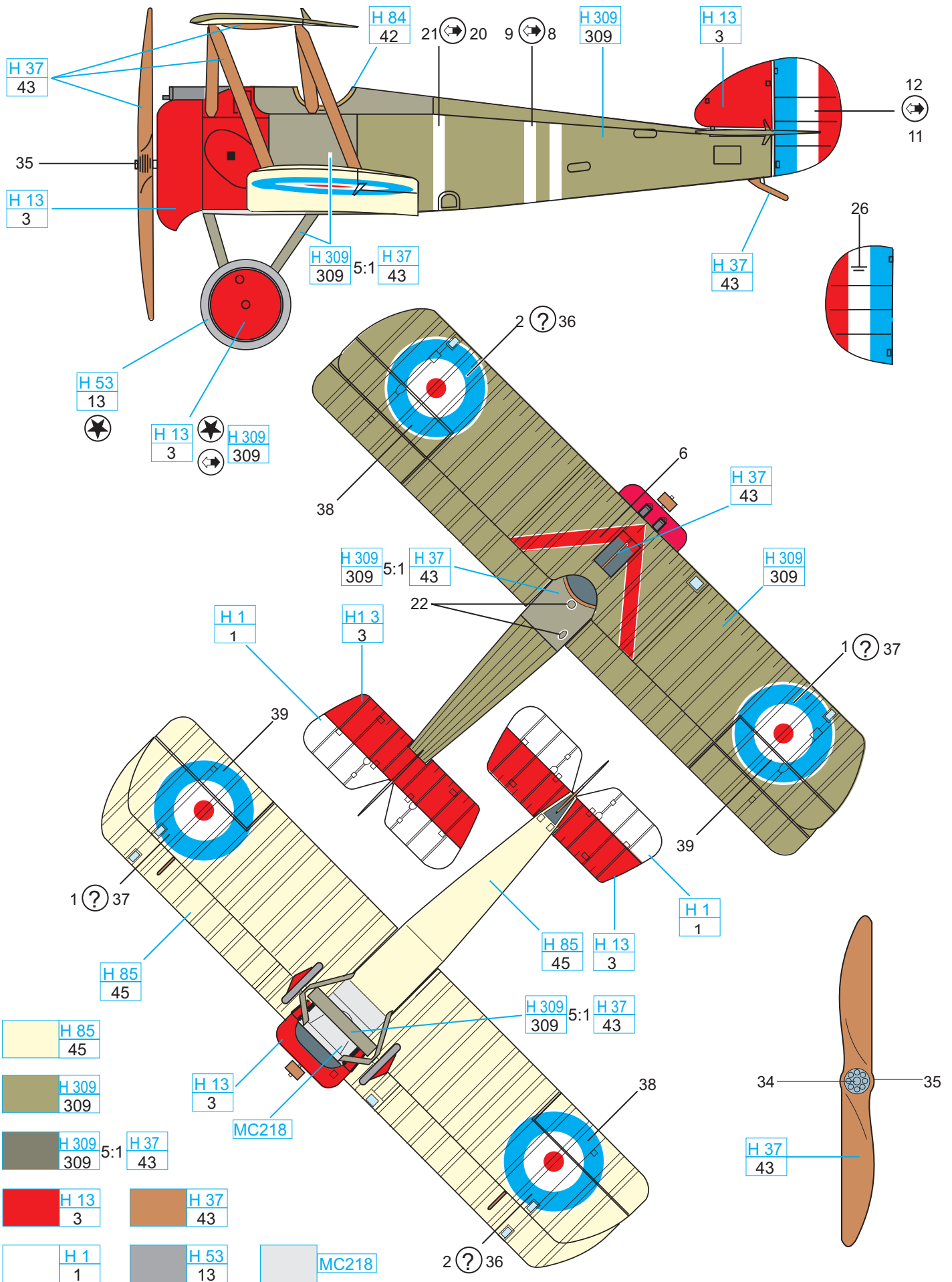

B Sopwith Camel F.1 B2455, Lt E.G.Forder, No 28 Sqn, Italy, May 1918

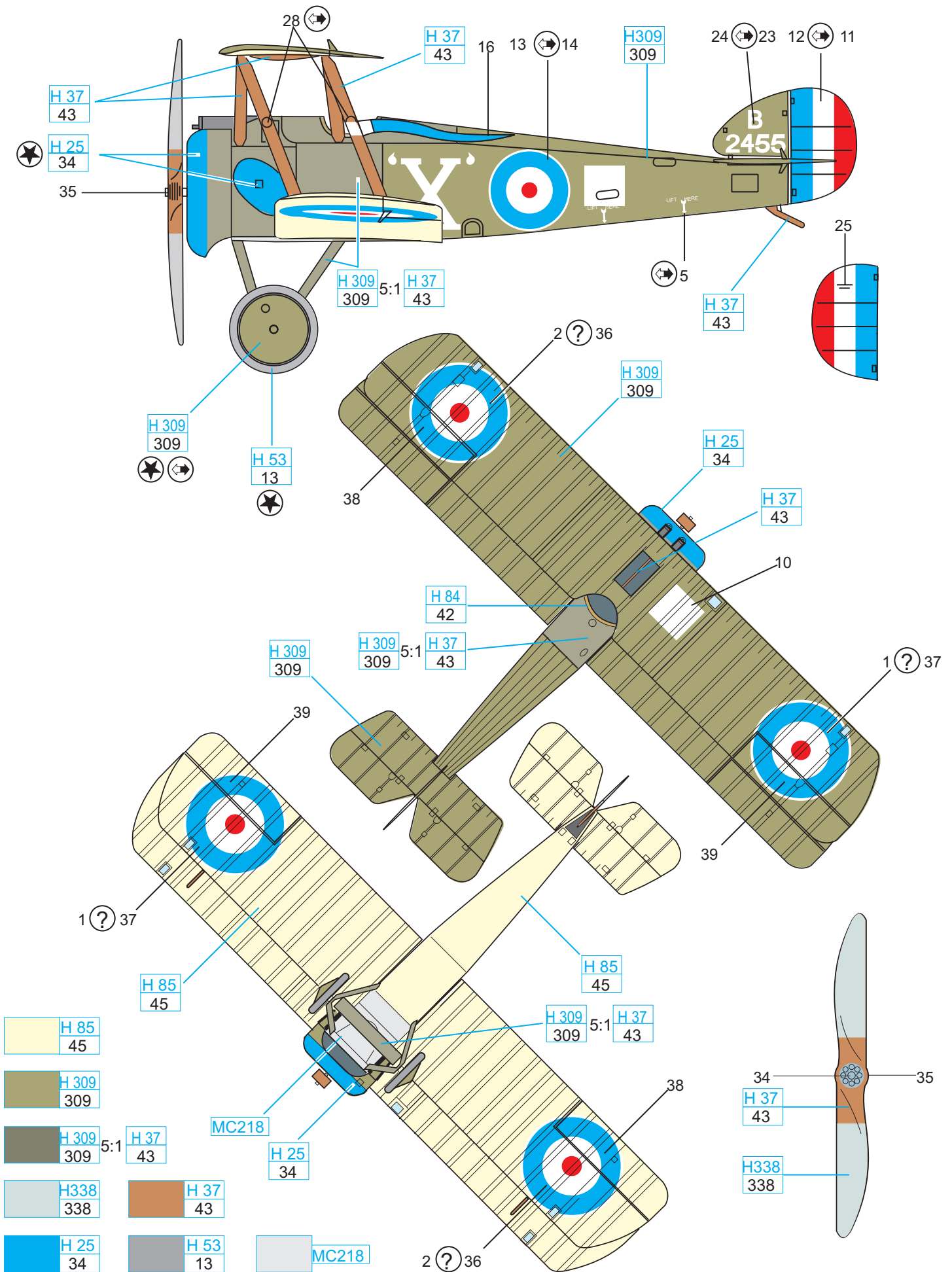

C Sopwith Camel F.1 F2137, Capt D R MacLaren, No 46 Sqn, Athies, France, October 1918

