

Uwaga!

Przed rozpoczęciem pracy dokładnie przeczytaj instrukcję. Zachowaj zasady bezpieczeństwa przy pracy z łatwopalnym klejem i farbami! Trzymaj model z dala od małych dzieci. Nie pozwalaj im brać do ust/nosa części plastikowych lub naciągać na głowę torebek plastikowych!

Wsparcie klienta: W przypadku jakichkolwiek problemów z modelem bez wahania wypełnij formularz zgłoszenia na stronie:

<http://www.armahobby.pl/webpage/wsparcie-faq.html>

Warning!

Before you start, please read the instructions carefully. Working with flammable glue and/or paint: please follow the safety recommendation of the manufacturers. Keep out of reach of small children! Do not allow them to place plastic parts in their mouths or noses or to pull plastic bags over their heads. **Customer care:** In case of any problems with the model, please do not hesitate to contact us and fill the claim form on our website:

<http://www.armahobby.com/webpage/wsparcie-faq.html>

Hawker Hurricane Mk.II to kolejna odmiana słynnego myśliwca konstrukcji Sydneya Camma. Powstała poprzez zabudowanie w standardowym płatowcu silnika Rolls- Royce Merlin XX wyposażonego w dwustopniową sprężarkę. Rozwiązanie to znacznie poprawiło osiągi samolotu. Nowa wersja oznaczona jako Hurricane Mk.IIa oblatana została w dniu 11 czerwca 1940r. a już w sierpniu tego roku pierwsze egzemplarze trafiły na uzbrojenie dywizjonów RAF. W tym czasie firma Hawker prowadziła badania mające na celu poprawienie uzbrojenia strzeleckiego. Badania te polegały na zastosowaniu działek w różnych konfiguracjach. Początkowo wprowadzono wariant z 12 karabinami maszynowymi 7.69 mm w skrzydłach, pod oznaczeniem Hurricane Mk IIb. Niestety mały kaliber uzbrojenia nie zmienił znacząco skuteczności ostrzału z tego samolotu. Wersja ta była później szeroko wykorzystywana do bombardowania, i znana jako „Hurribomber”. Podczas podwieszania bomb z reguły usuwano jeden z karabinów maszynowych, w miejscu montażu zaczepu bombowego. Zastosowanie silnika Merlin XX umożliwiło zabudowanie czterech działek British Hispano kalibru 20 mm. Odmiana ta, oznaczona jako Hurricane Mk.IIc okazała się najliczniej wyprodukowaną wersją tego myśliwca. Łącznie, wraz z maszynami przebudowanymi z odmian A i B powstało 4711 egzemplarzy. Zmieniło się także przeznaczenie samolotu. Nie był to już klasyczny samolot myśliwski, ale głównie samolot myśliwsko-szturmowy. Samoloty te były wykorzystywane do atakowania celów naziemnych, ogniem działek lub przez bombardowanie. Poprzez montaż tropikalnego filtra powstała wersja „Trop” przeznaczona do działań w gorącym klimacie. Tak wyposażone samoloty Mk IIb i c wzięły udział w walkach w Afryce i na Dalekim Wschodzie. Samoloty Hurricane Mk IIa/b były używane bojowo przez dywizjony Polskich Sił Powietrznych w Wielkiej Brytanii, przed przebrojeniem na Spitfire. Samoloty Hurricane Mk II stosowano też do szkolenia dywizjonów myśliwsko-rozpoznawczych: 309 (IIc) i 318 (IIb/c).

Hawker Hurricane Mk.II is a developed marking of the famous Sydney Camm fighter aeroplane. It was created by building in a standard Mk.I airframe the Rolls-Royce Merlin XX engine equipped with a two-stage compressor. It has significantly improved the aircraft's performance – the new marking marked as Hurricane Mk. IIa was flown on June 11, 1940. And already in August this year, the first aeroplanes went to the armament of RAF squadrons.

At that time, Hawker researched to improve the armament. These studies involved the use of cannons in various configurations. The first change was the installation of 12 machine guns 7.69 mm in wings. It was produced as Hurricane Mk. IIb. But the results were unsatisfactory, mainly because of small calibre of guns. The aeroplane was widely used as a fighter-bomber and known as „Hurribomber”. One wing machine gun was usually removed in units to accommodate wing bomb rack in those aeroplanes.

The use of the Merlin XX engine enabled the installation of four 20mm British Hispano cannons. This variant, designated as Hurricane Mk. IIc, proved to be the most-produced marking of this fighter. In total, 4,711 copies were created together with the machines rebuilt from A and B variants. The purpose of the aircraft has also changed. It was no longer a classic fighter aircraft, but mainly a fighter-attack plane. These aircraft were used to attack ground targets with cannon fire. By installing a tropical filter, the „Trop” marking was designed for operations in hot climates. Planes equipped in this way took part in the fighting in the Mid East and the Far East. Hurricanes IIa/b were used in combat in Polish squadrons in the UK before refitting with Spitfires. Fighter Reconnaissance squadrons used them for training: 309 (IIc) and 318 (IIb/c).

Podziękowania: Grzegorz Cieliszak; **Tekst:** Marcin Wawrzynkowski, KPM

Acknowledgement: Grzegorz Cieliszak; **Text:** Marcin Wawrzynkowski, KPM

Kalkomanie/Decals

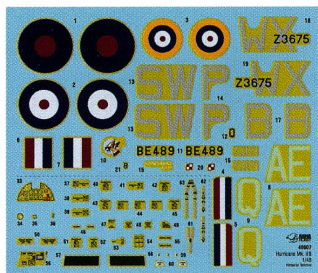

Części przezroczyste/Clear parts/Maski/Masks

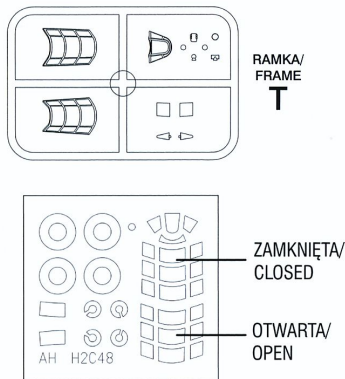

Części plastikowe/Plastic parts

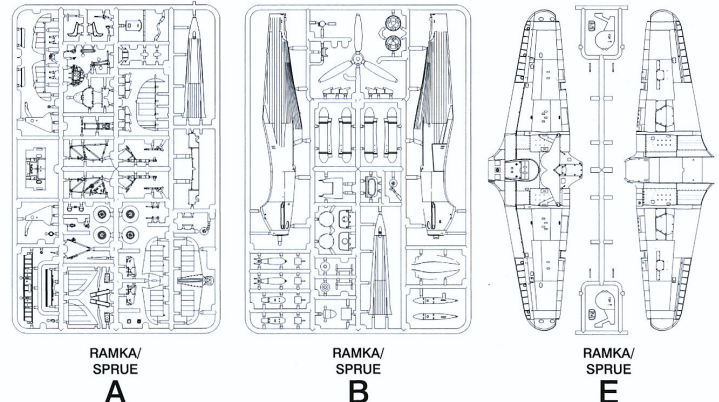

Kolory farb/ Paint colours	Hataka	AK RC	Mission Models	AMMO	Humbrol	Vallejo	Tamiya	Kolory farb/ Paint colours	Hataka	AK RC	Mission Models	AMMO	Humbrol	Vallejo	Tamiya
A Matt Silver FS 37178	HTK-A003/ C003	RC210	MMM-006	195	11	71.063	X-11	G Dark Green FS34092	HTK-A016/ C016	RC286	MMP-058	915	116	71.324	XF-81
B Matt Black FS37038	HTK-A100/ C100	RC001	MMP-047	046	33	71.057	XF-1	H Dark Earth FS30118	HTK-A009/ C009	RC287	MMP-078	070	29	71.057	XF-52
C Interior Grey Green FS34226	HTK-A025/ C025	RC293	MMP-079	219	78	71.305	XF-71	I Sky Type S FS34583	HTK-A026/ C026	RC290	MMP-080	0243	90	71.302	XF-21
D Gun Metal	HTK-A106/ C106	RC015	MMM-010	045	53	71.073	X-10	J Ocean Grey FS36176	HTK-A032/ C032	RC288	MMP-093	245	106	71.273	XF-82
E Insignia Red FS11136	HTK-A219/ C219	RC006	MMP-101	049*	153	71.102*	X-7*	K Medium Sea Grey S36270	HTK-A034/ C034	RC289	MMP-094	243	165	71.307	XF-83
F Insignia Yellow FS13538	HTK-A066/ C066	RC008	MMP-007	048	154	71.002	XF-3	L Faded Yellow	-	RC263	MMP-67	221	74	71.107	XF-4

*Kolor zbliżony/approximate colour

Więcej informacji na temat budowy tego modelu: <http://armahobbynews.pl/blog/tag/nr40007/>

More advice on building this kit: <http://armahobbynews.pl/en/blog/tag/nr40007-en/>

Manufacturer: Arma Hobby S.C.
Ostrobramska 101/200; 04-041 Warszawa, Poland
www.armahobby.pl www.armahobby.com
kontakt1@armahobby.pl
© 2023 Arma Hobby S.C. all rights reserved



montaż symetryczny/
symmetrical assembly



zegnij/
bend



usuń/
remove



obróć/
rotate



kalkomania/
decals



nawierć/
drill



zwiń/
roll



wybór/
option

DLA PODWIESZENIA ZBIORNIKÓW ZAPASOWYCH (A) LUB WYRZUTNIKÓW BOMBOWYCH (B) NAWIERĆ OD WEWNĄTRZ. UŻYJ BOMB DLA MAŁOWANIA 1. NIE UŻYWAJ ZBIORNIKÓW DODATKOWYCH DLA MAŁOWAŃ PUDEŁKOWYCH/ FOR AUXILIARY TANKS (A) OR BOMBS RACKS (B) DRILL APPROPRIATE HOLES FROM INSIDE. NONE OF THE BOX SCHEMES USE THE AUXILIARY TANKS. BOMBS ONLY FOR PAINTING OPTION 1.

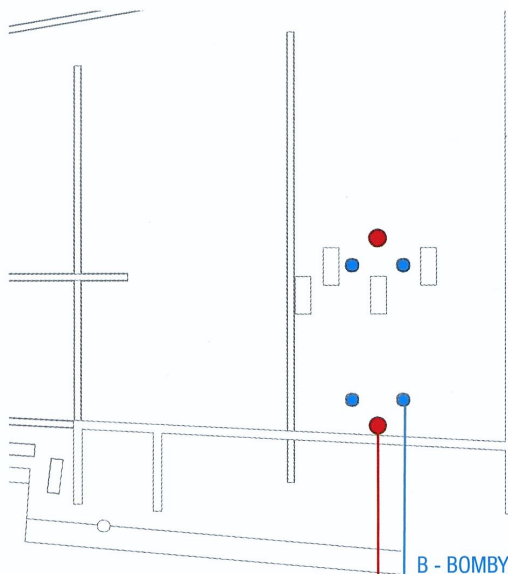

B - BOMBY/ B - BOMBS

A - ZBIORNIKI/ A - AUXILIARY TANKS

A

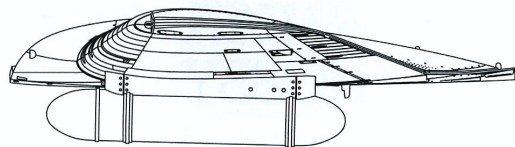

B

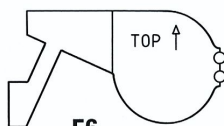
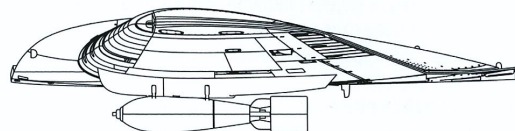

E6

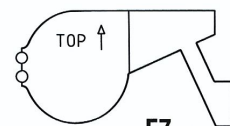

E7

PLASTIKOWE MASKI DO ZASŁONIĘCIA WNEK PODWOZIA PRZY MAŁOWANIU / PLASTIC MASKS FOR WHEEL WELLS, YOU CAN USE WITH PAINTING WINGS UNDERSIDES

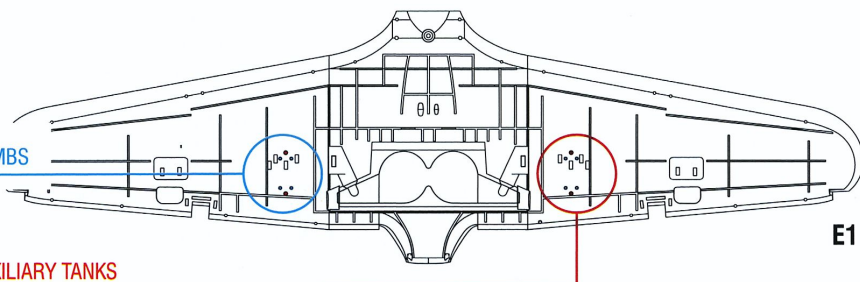

E1

1

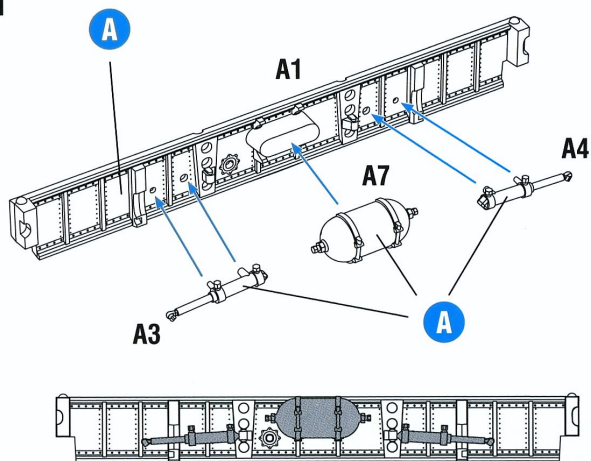

2

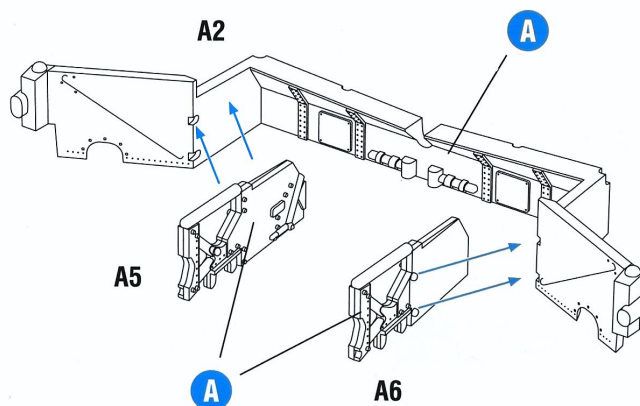

3

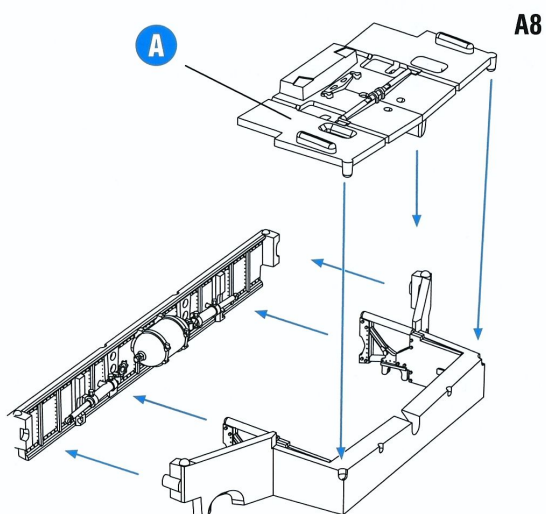

4

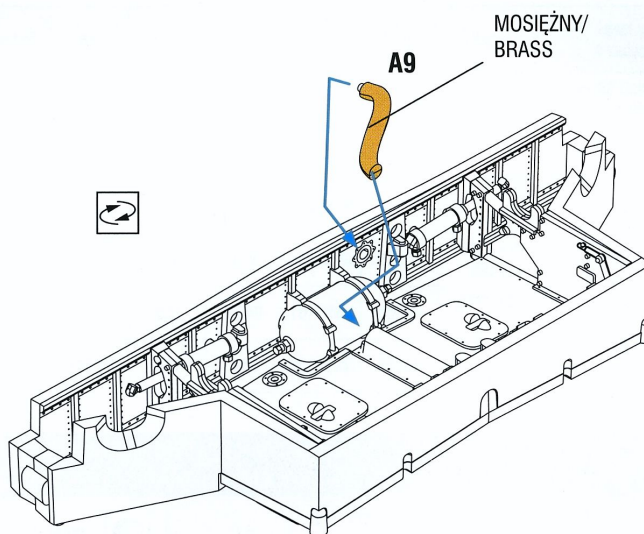

MOSIĘŻNY/
BRASS

A9

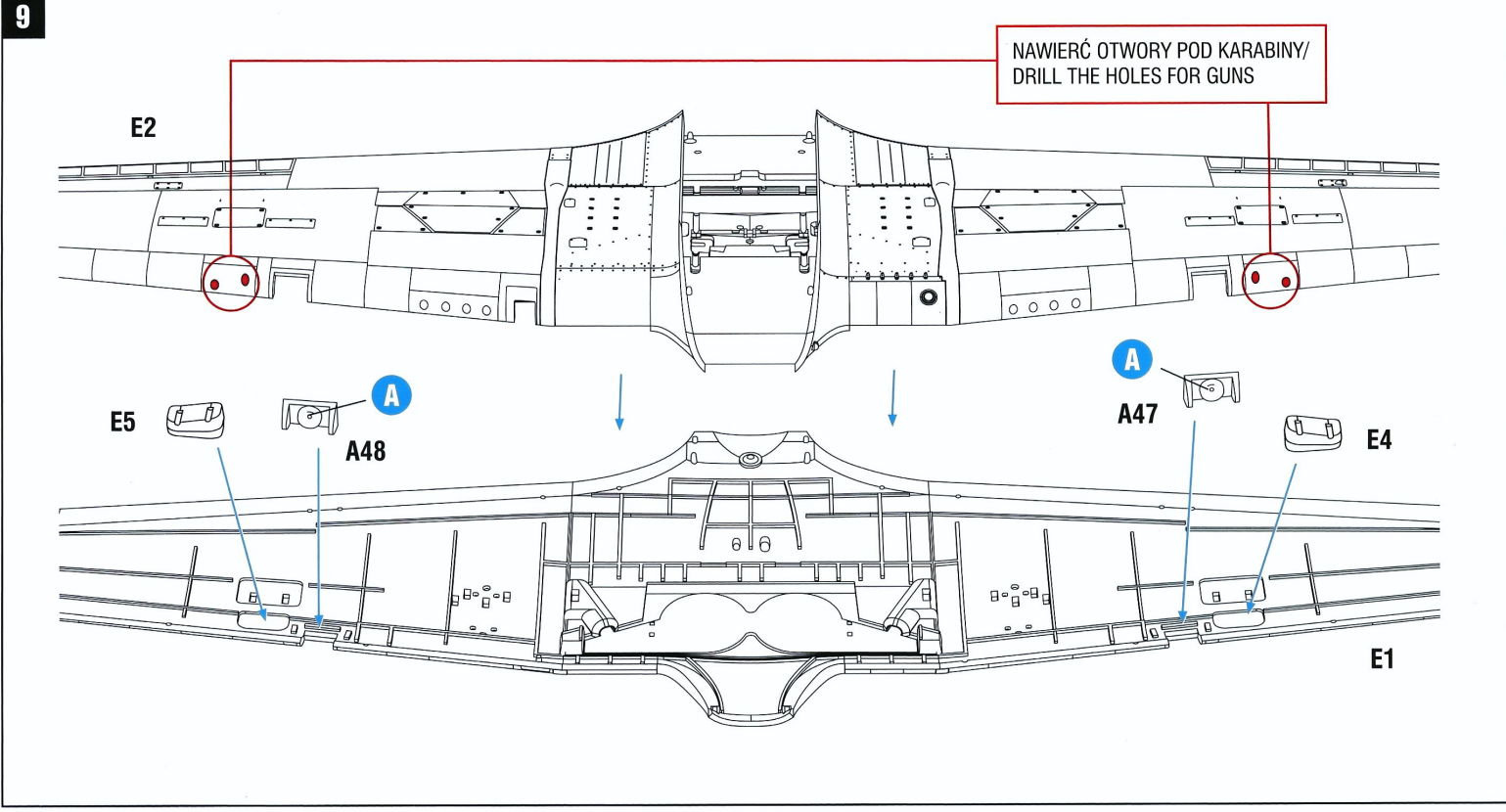
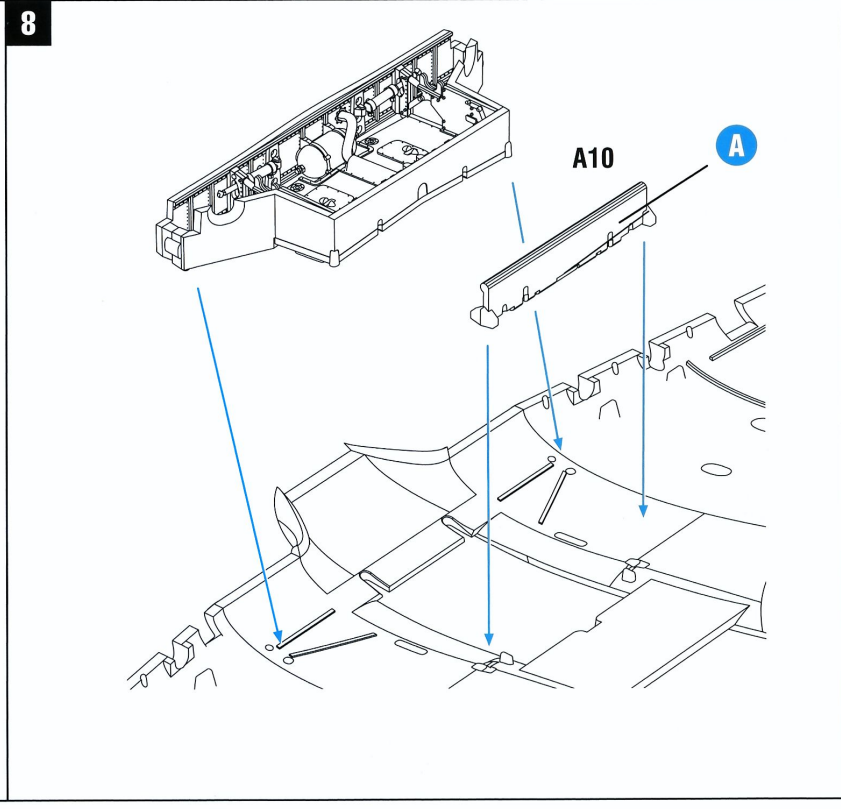
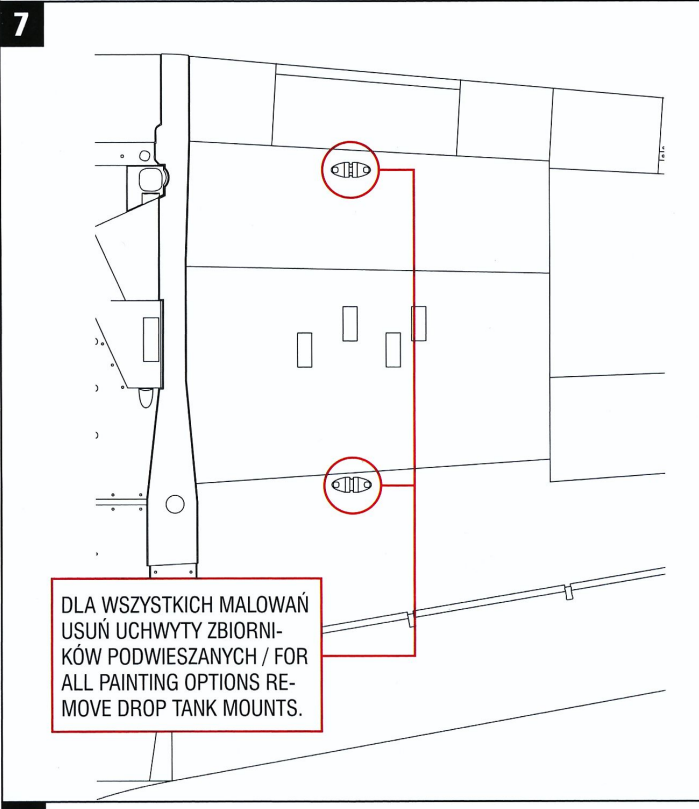
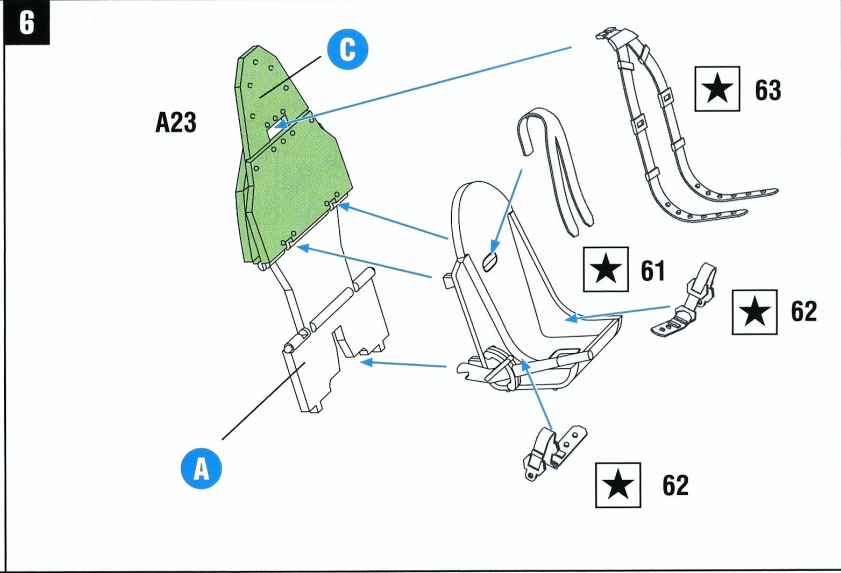
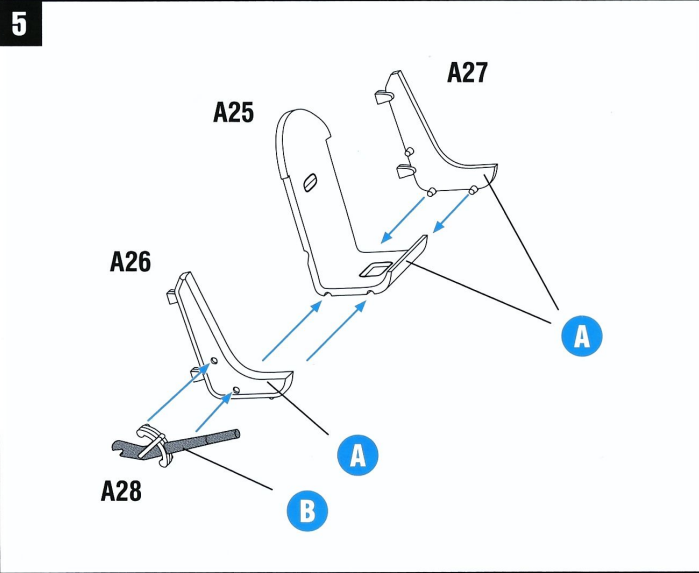

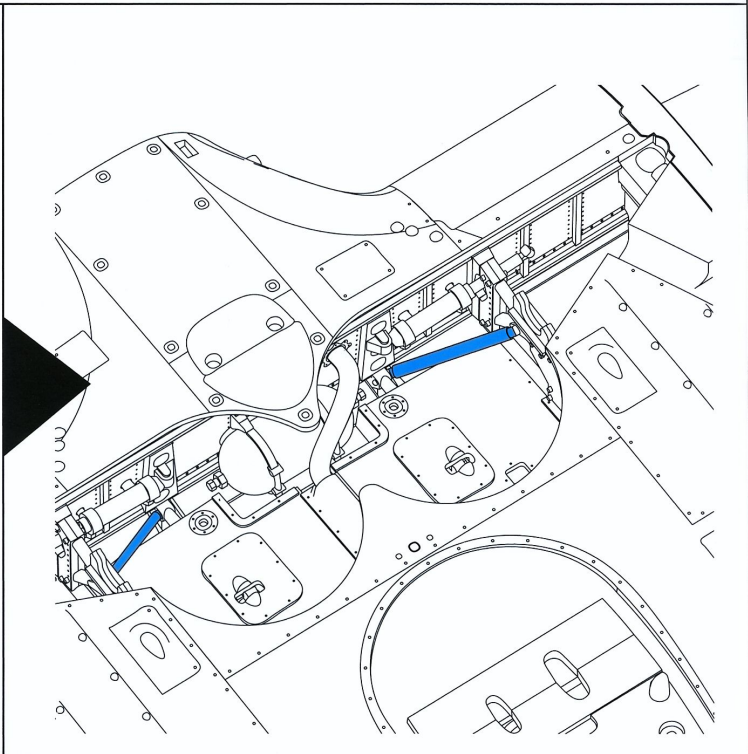
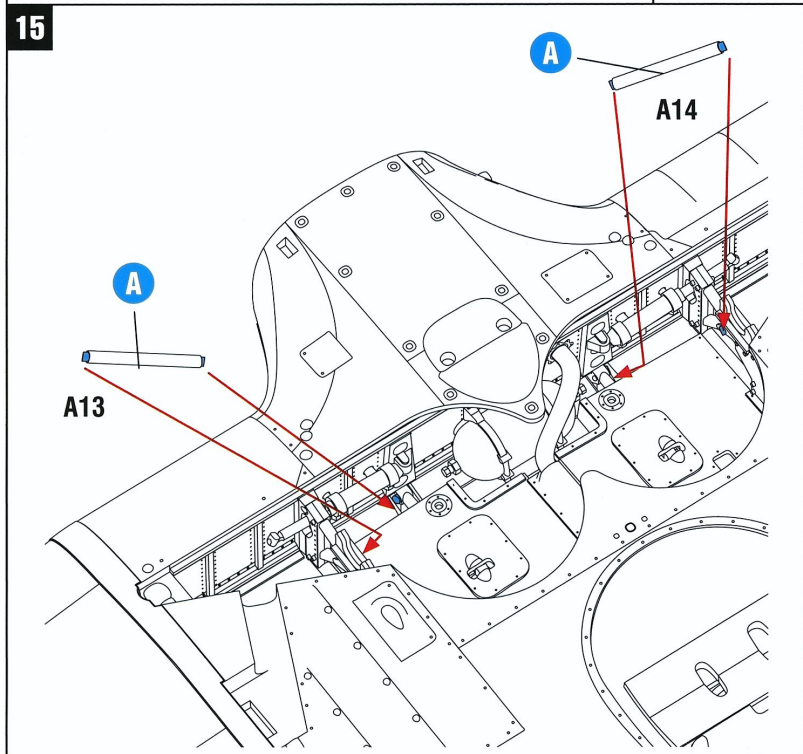
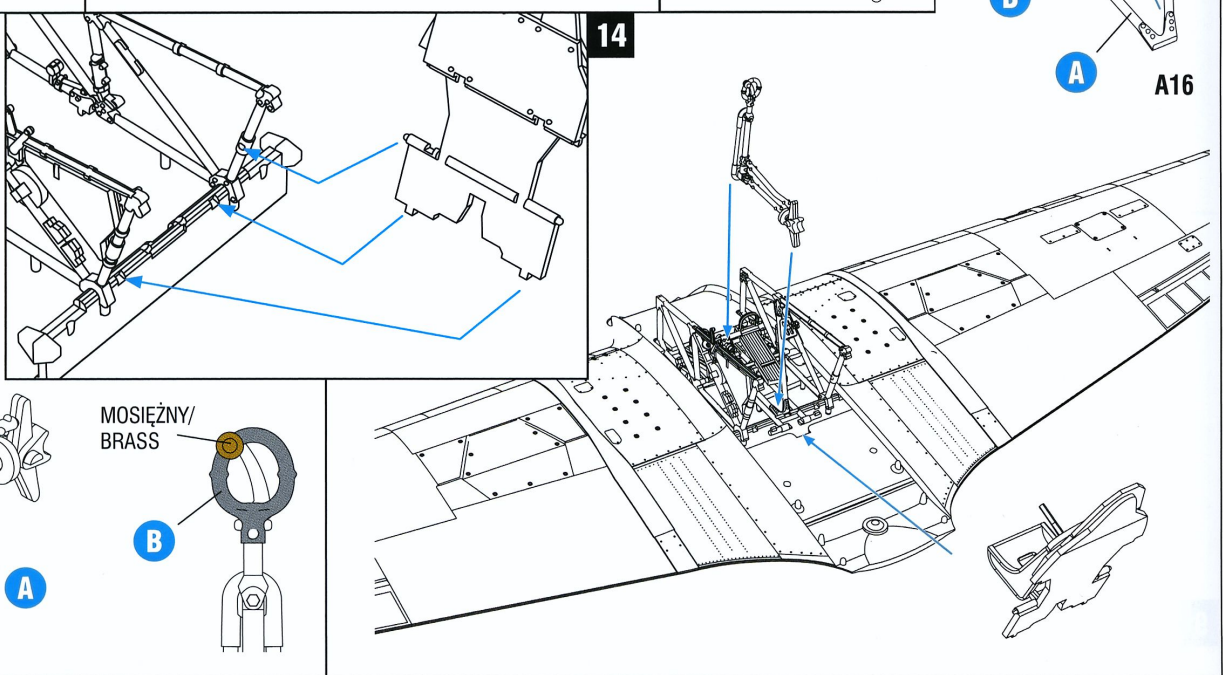
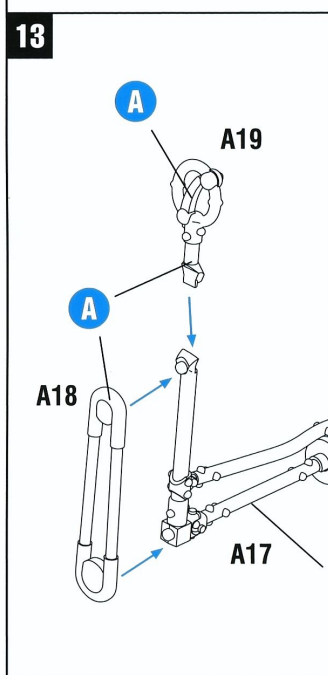
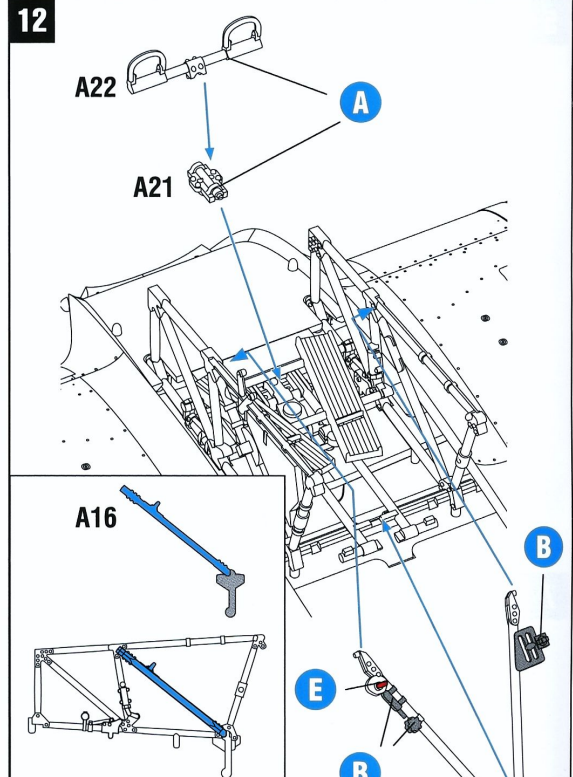
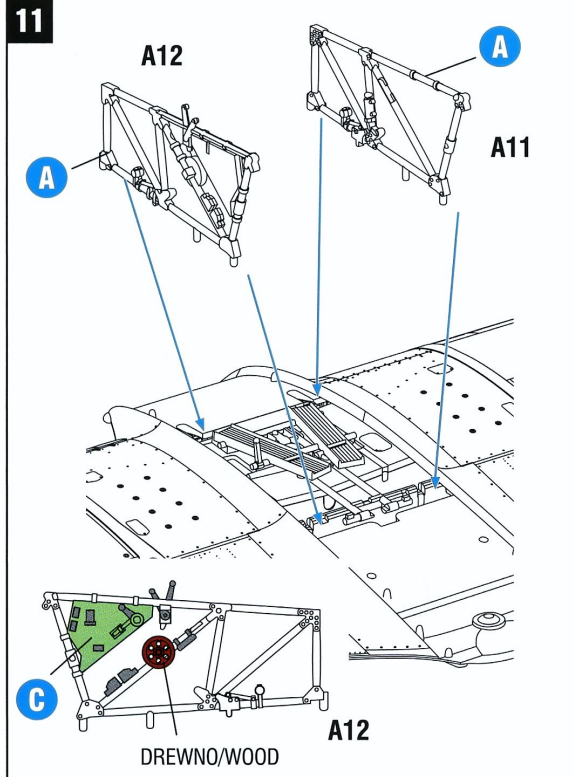
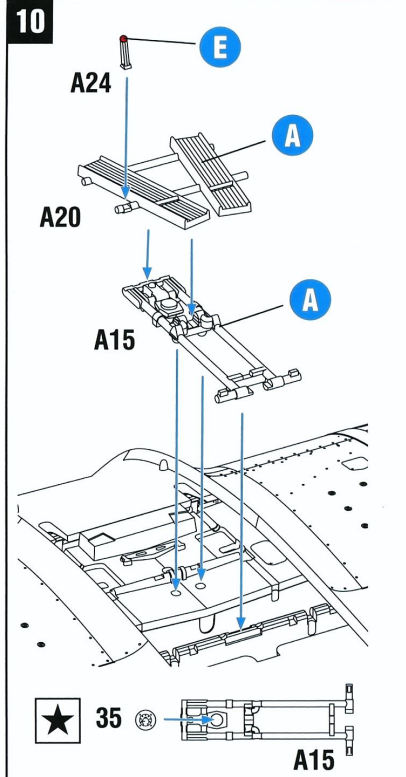

16

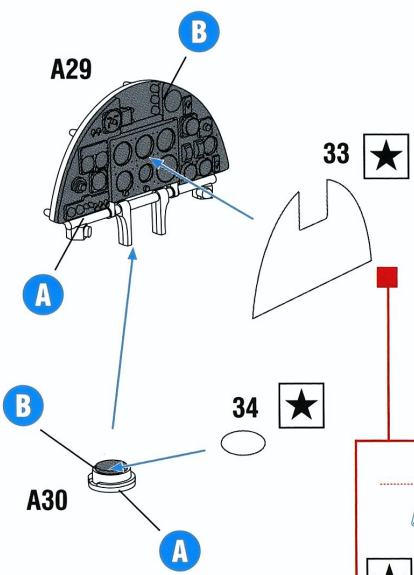

★ 33

POROZCINAJ DLA ŁATWIEJSZEGO UKŁADANIA / CUT FOR PIECES FOR BETTER FIT

★ 56

17

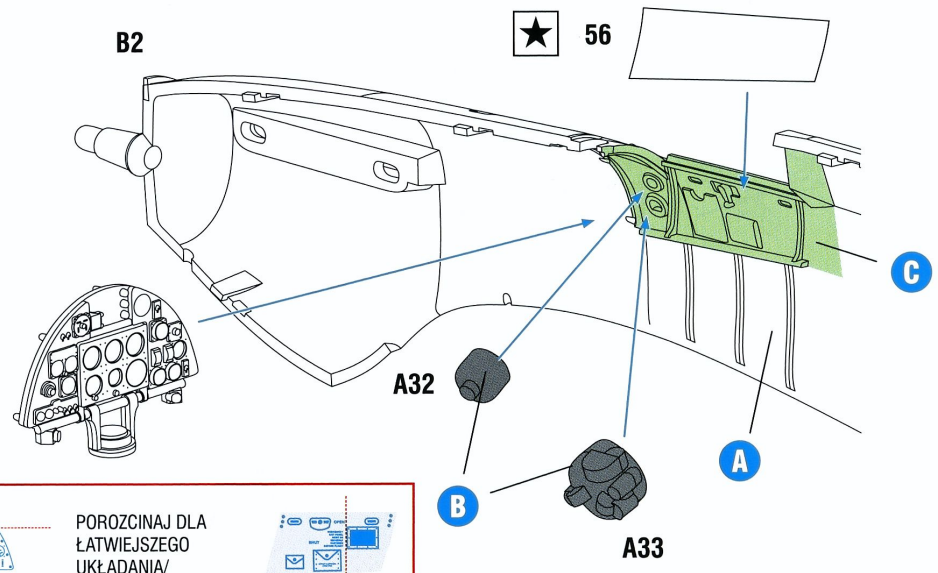

18

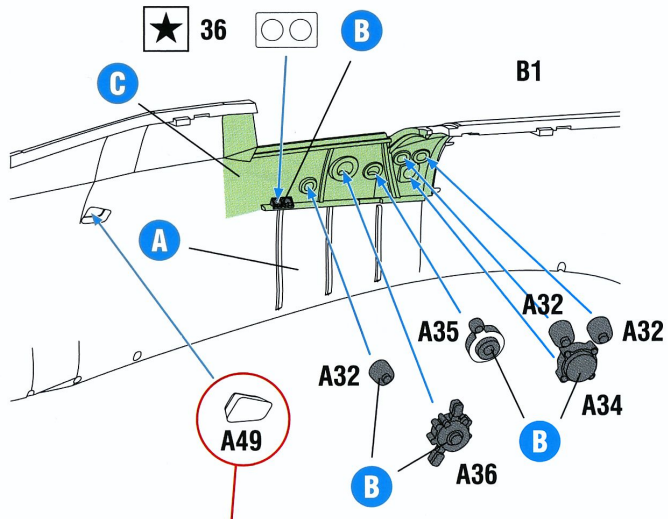

NIE WKLEJAJ CZĘŚCI A49 JEŚLI PLANUJESZ UŻYĆ CZĘŚCI A50 (STOPIEŃ W POZYCJI OPUSZCZONEJ) / DO NOT USE PART A49 IF YOU WANT TO MOUNT PART A50 (FOOT STEP IN THE LOW POSITION)

19

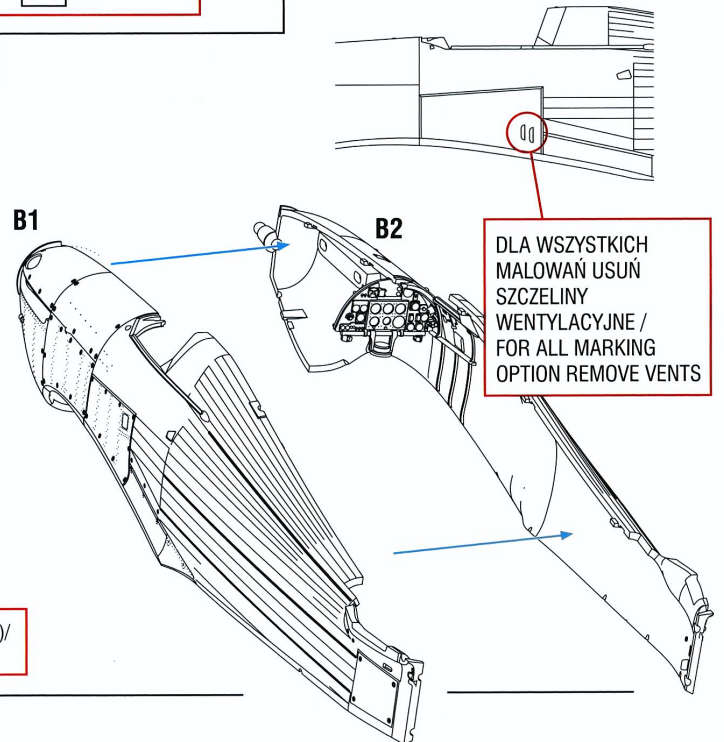

DLA WSZYSTKICH MALOWAŃ USUŃ SZCZELINY WENTYLACYJNE / FOR ALL MARKING OPTION REMOVE VENTS

20

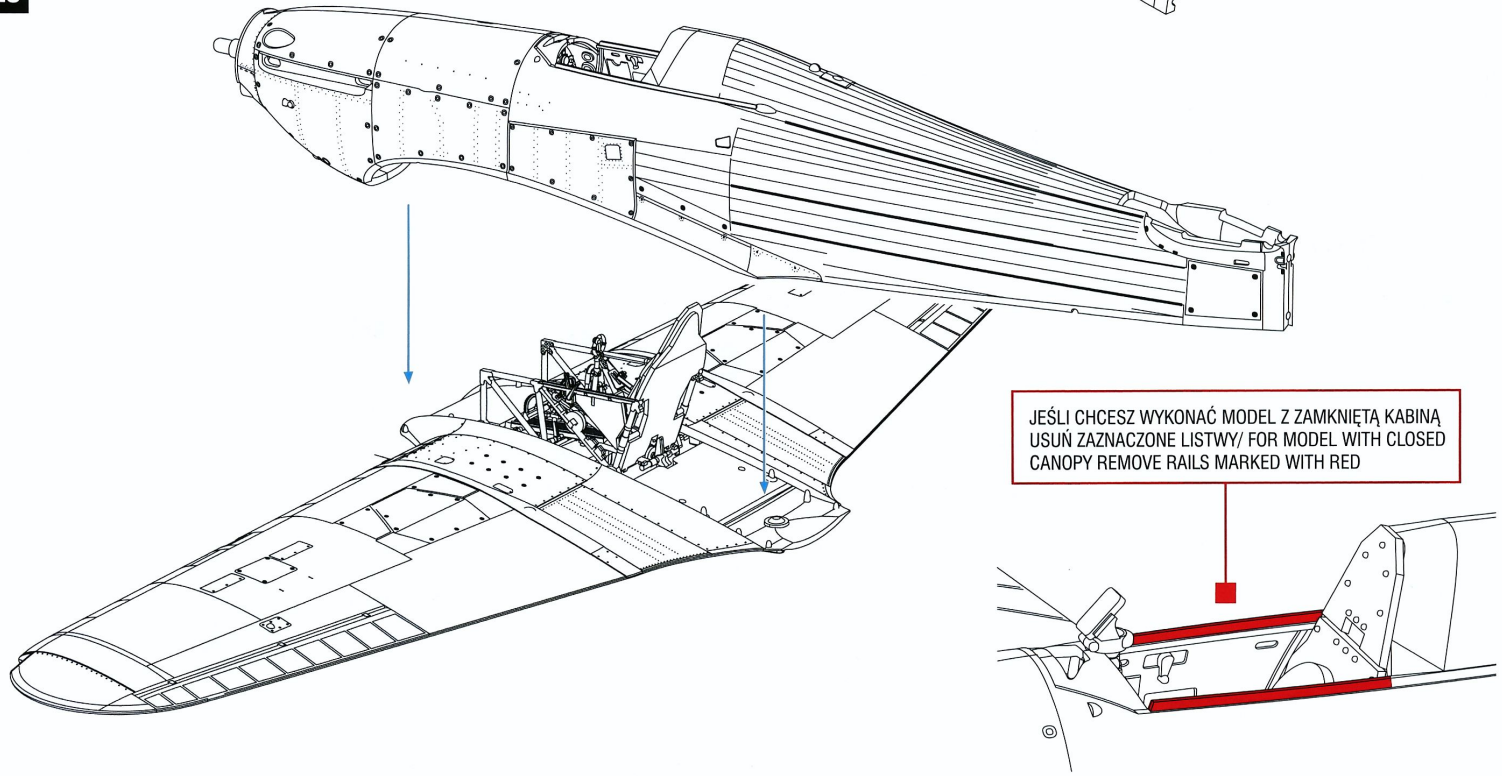

JEŚLI CHCESZ WYKONAĆ MODEL Z ZAMKNIĘTĄ KABINĄ USUŃ ZAZNACZONE LISTWY / FOR MODEL WITH CLOSED CANOPY REMOVE RAILS MARKED WITH RED

21 22

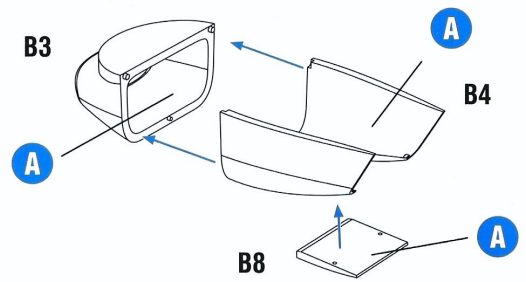
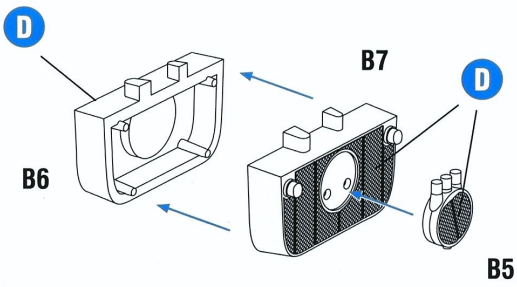

23

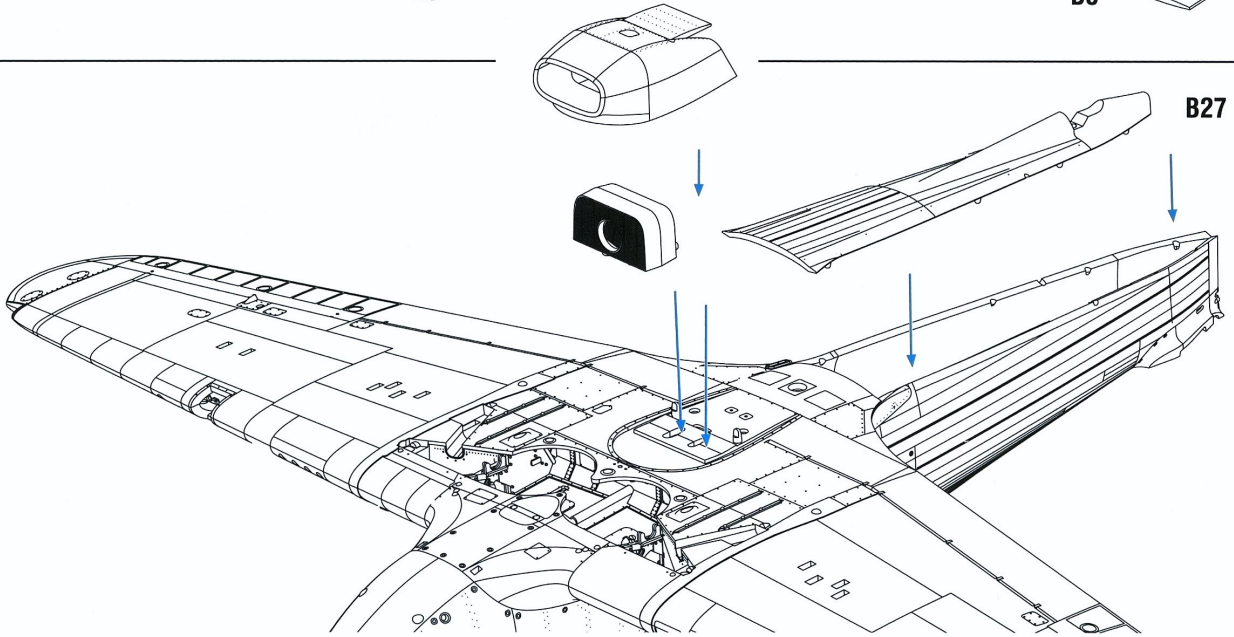

24

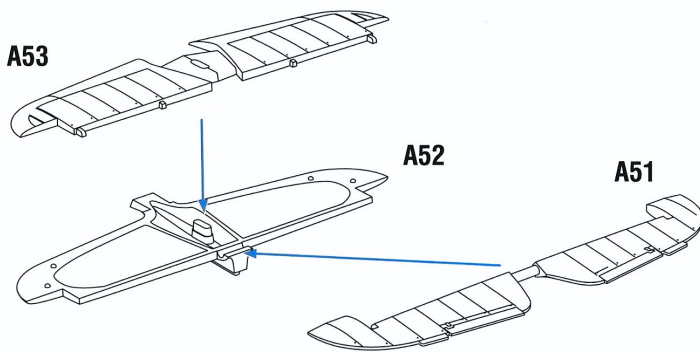

25

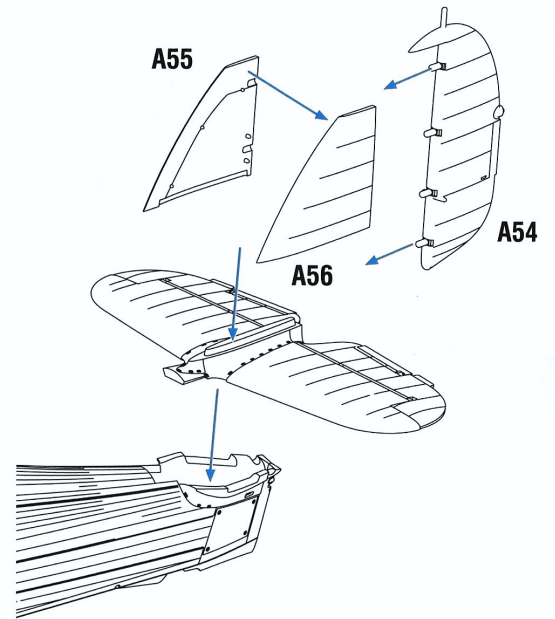

26

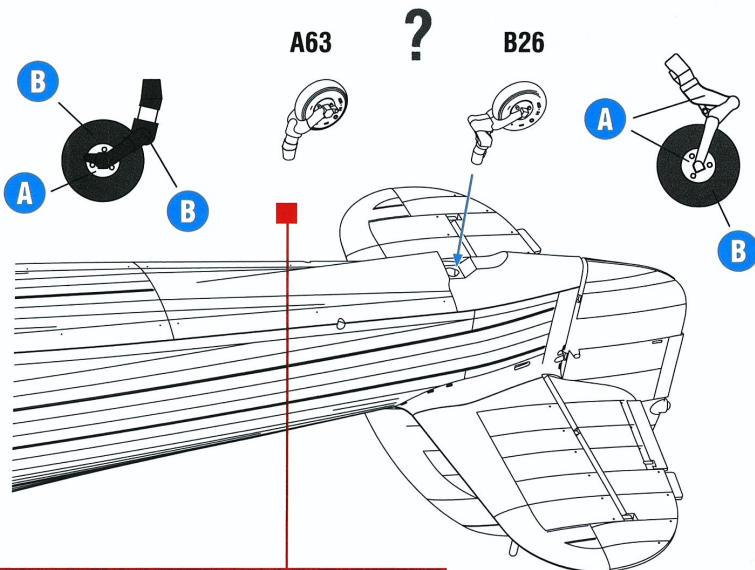

DLA MAŁOWANIA 2, 3 WKLEJ CZĘŚĆ NR A63 /
FOR MARKING OPTION 2, 3 CHOOSE PART NO. A63

27

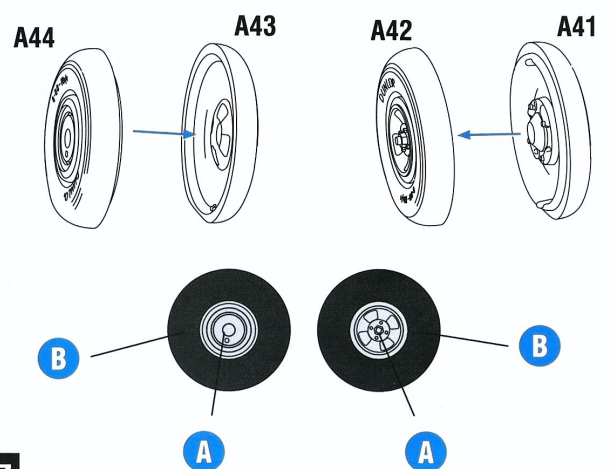

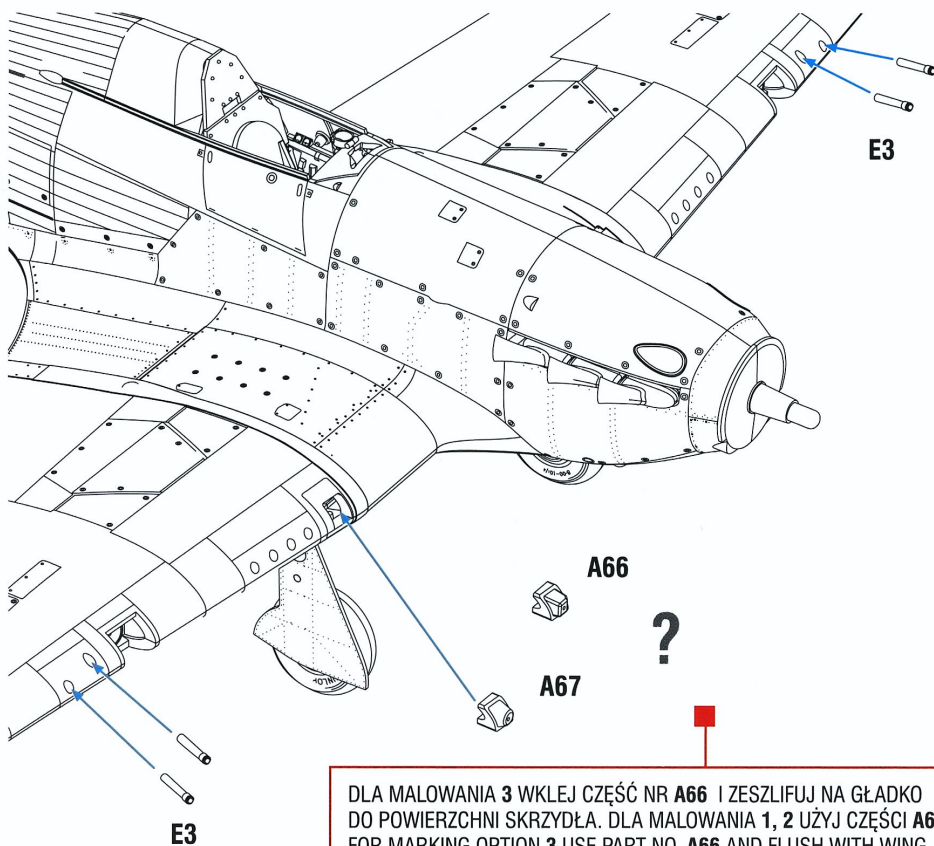
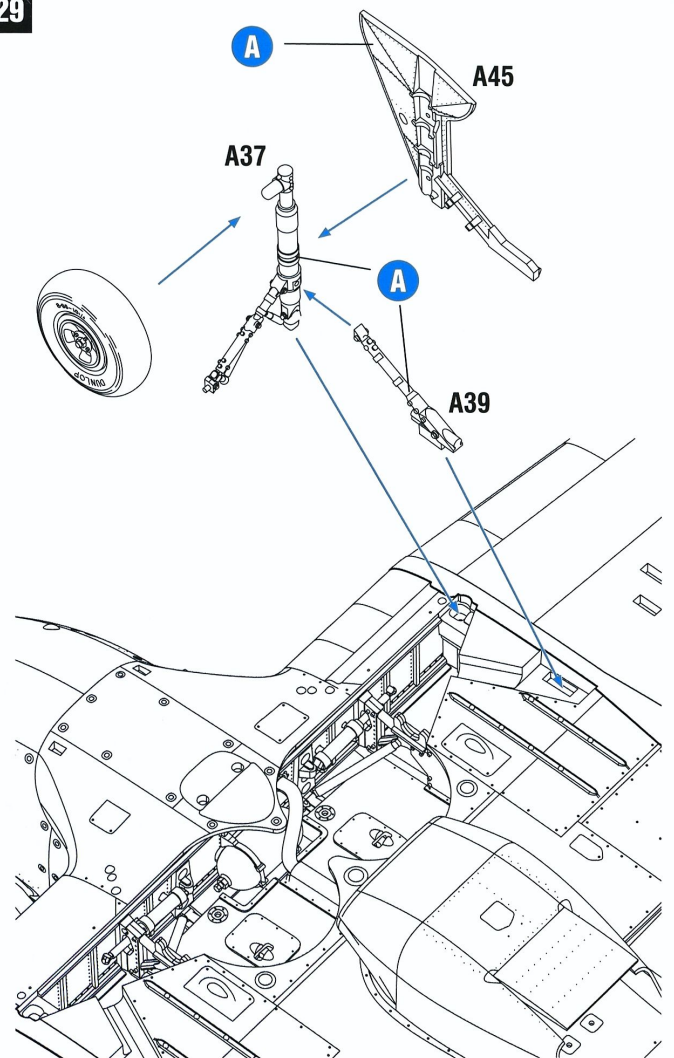
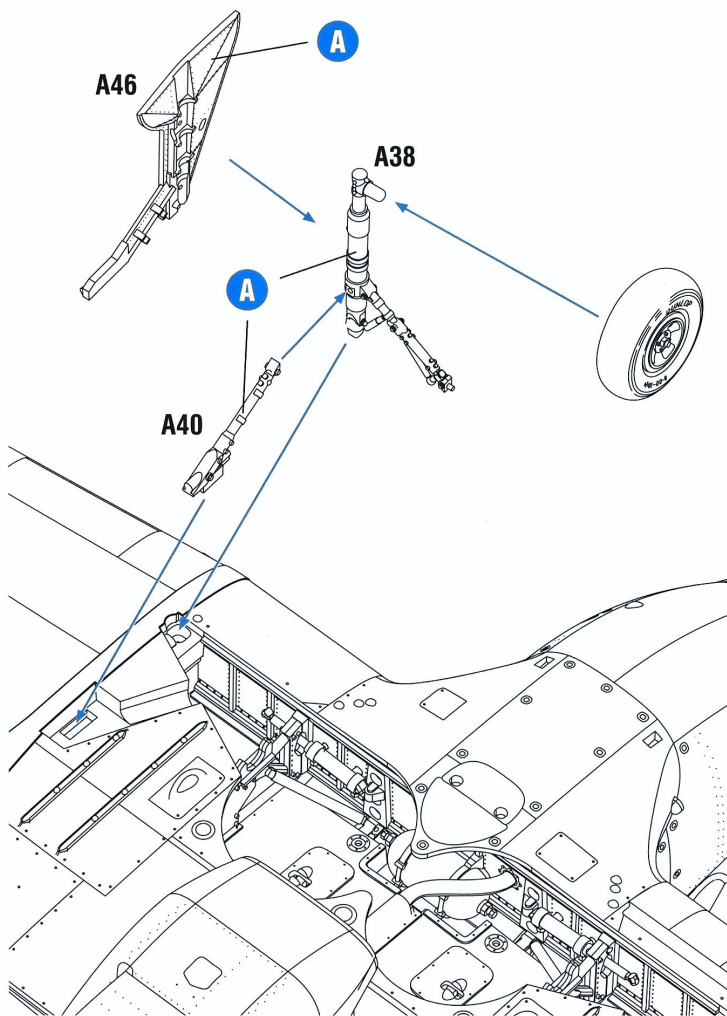

DLA MAŁOWANIA 3 WKLEJ CZĘŚĆ NR A66 I ZESZLIFUJ NA GŁADKO DO POWIERZCHNI SKRZYDŁA. DLA MAŁOWANIA 1, 2 UŻYJ CZĘŚCI A67/
FOR MARKING OPTION 3 USE PART NO. A66 AND FLUSH WITH WING SURFACE, FOR MARKING OPTION 1, 2 USE PART NO A67

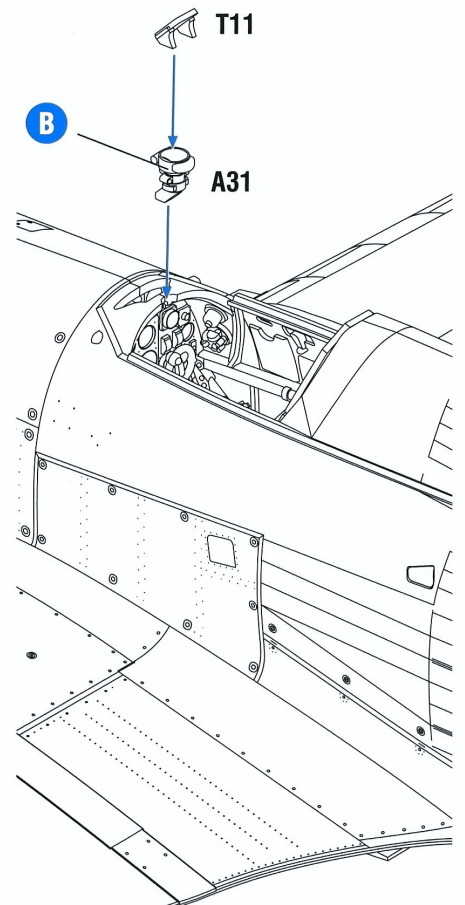

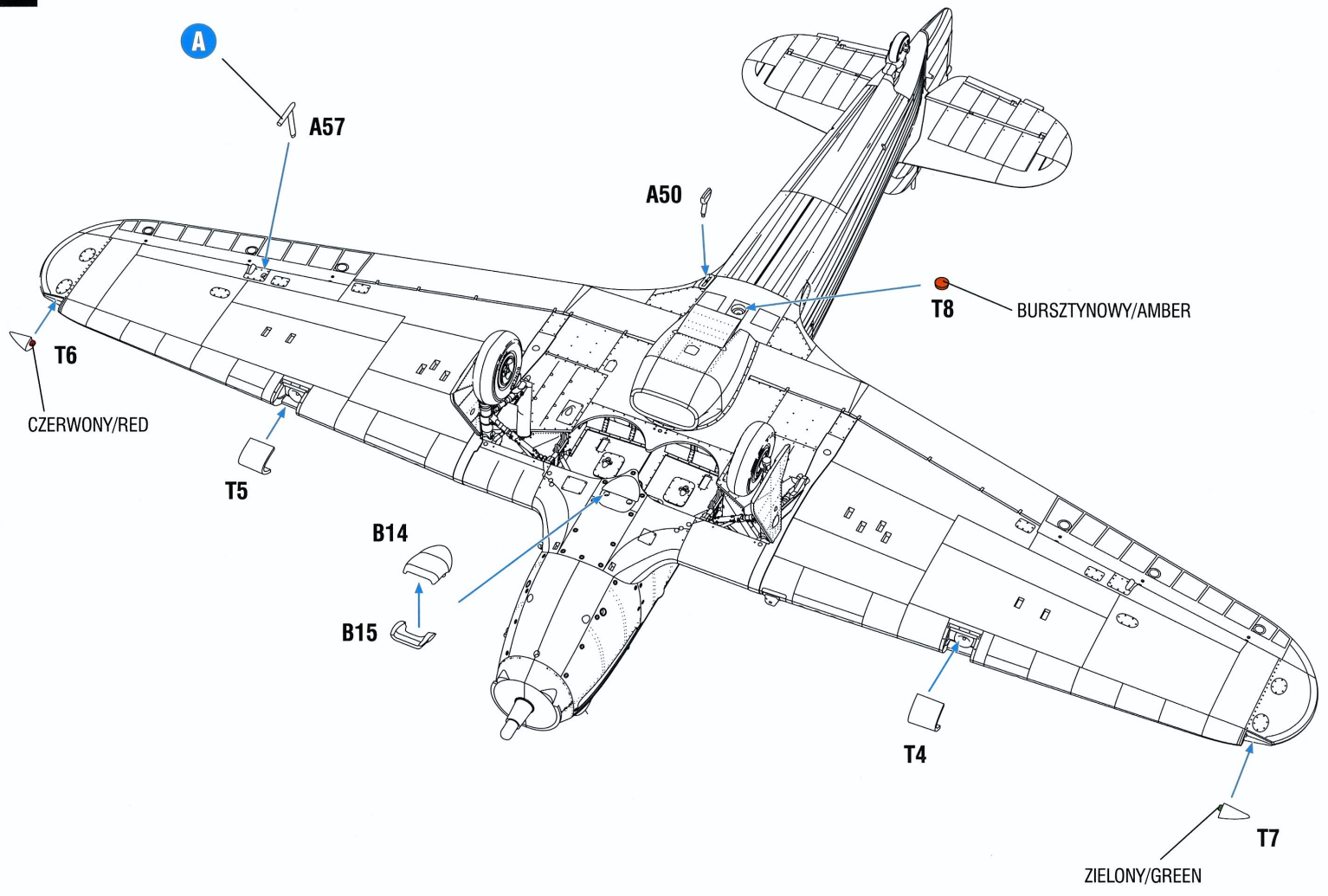

DLA MALOWANIA 1 UŻYJ CZĘŚCI B11, B13, B18, B9/
FOR MARKING OPTION 1 USE PARTS B11, B13, B18, B9

USUŃ DLA WSZYSTKICH MALOWAŃ/ REMOVE FOR ALL PAINTING OPTIONS

DLA MALOWANIA 1, 2/ FOR MARKING OPTION 1, 2

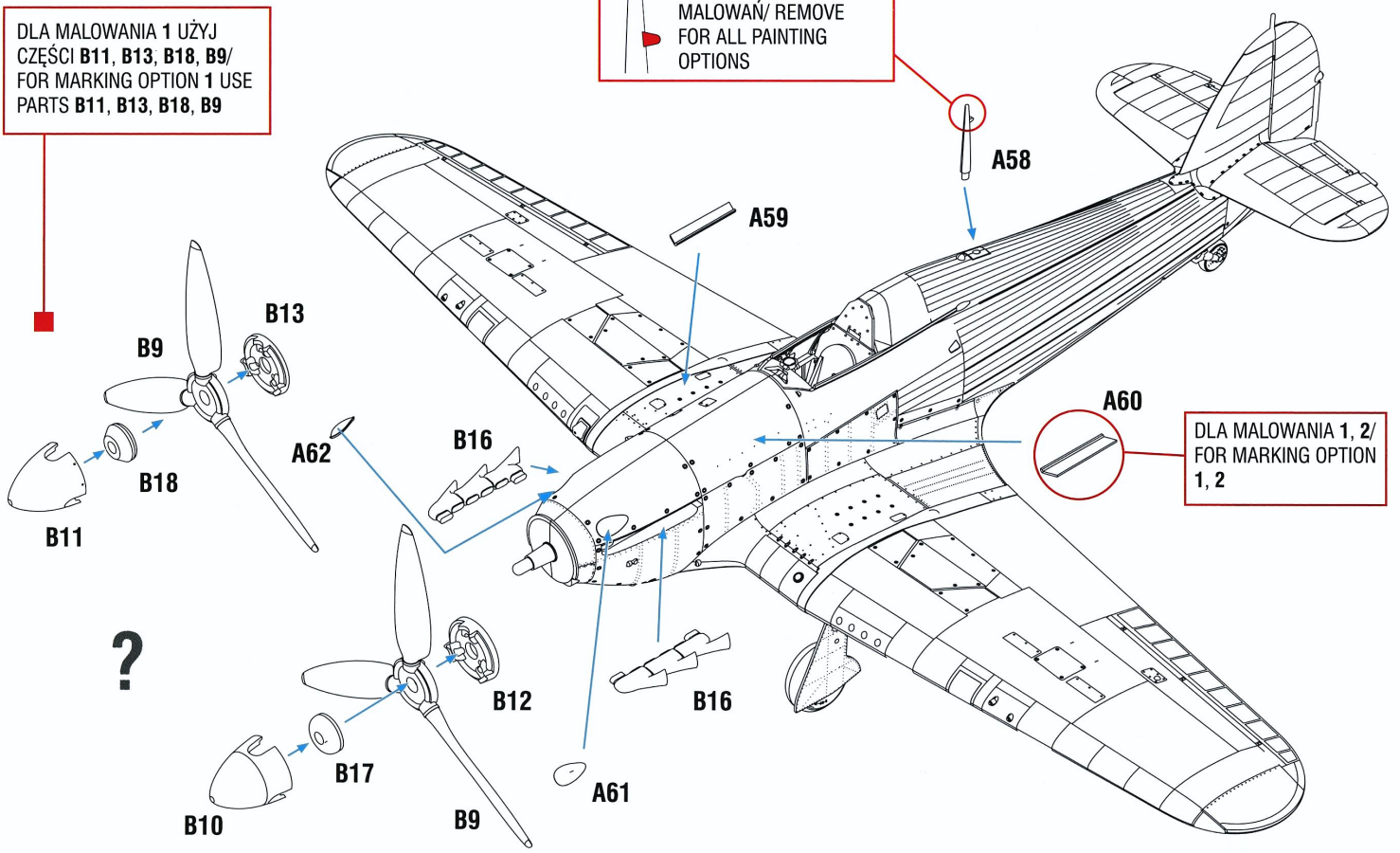

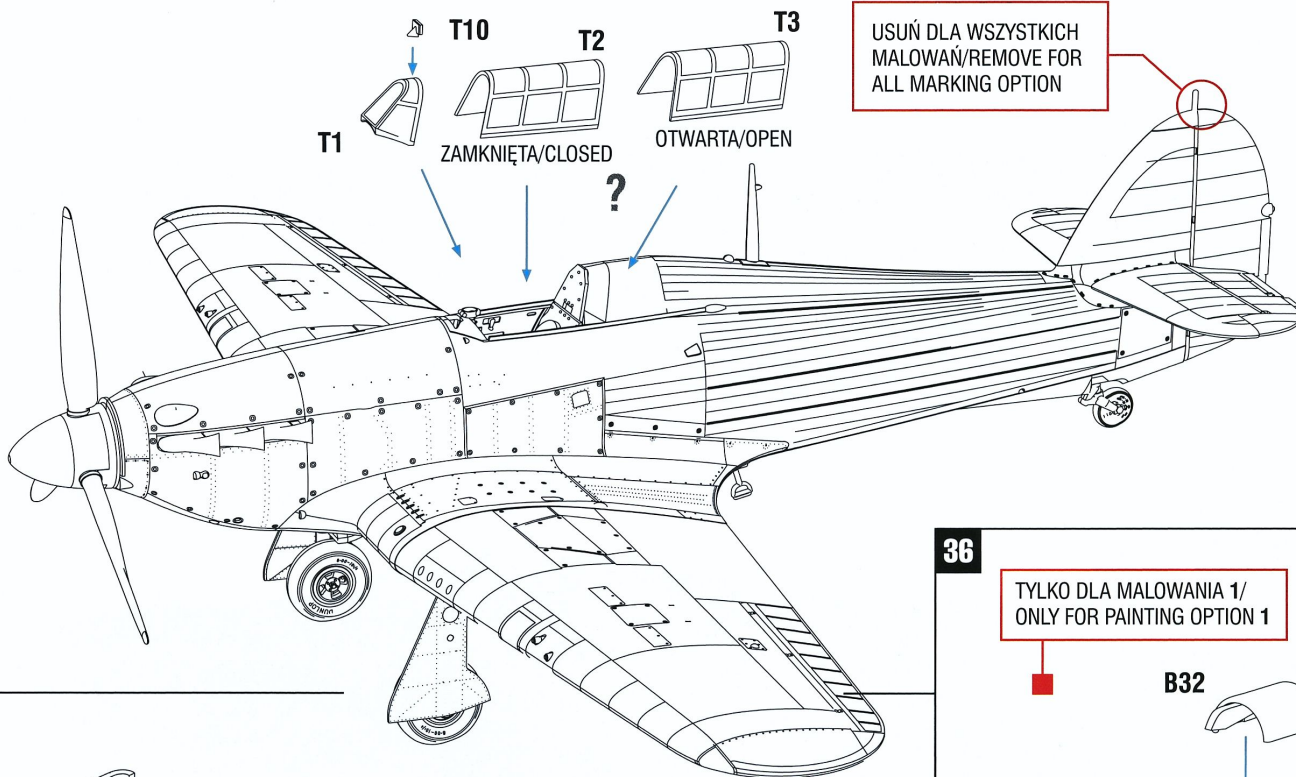

35

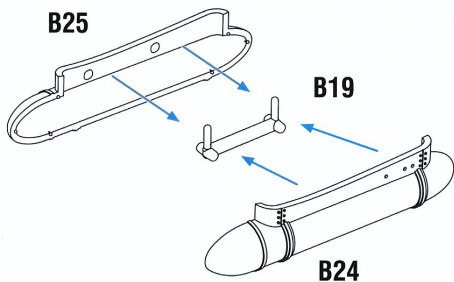

NIE UŻYWAJ DLA MALOWAŃ PUDEŁKOWYCH/
NONE OF THE BOX OPTIONS USE DROP TANKS

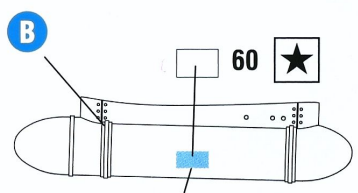
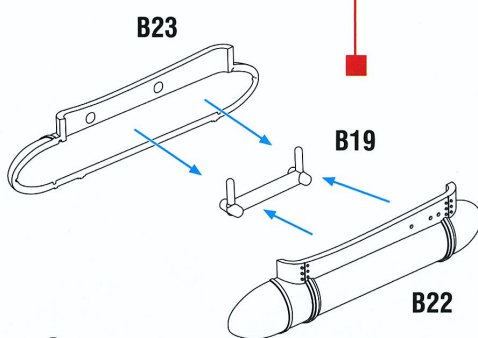

ZAWSZE PO LEWEJ STRONIE ZBIORNIKA/
ALWAYS AT THE LEFT SIDE OF THE TANK

36

TYLKO DLA MALOWANIA 1/
ONLY FOR PAINTING OPTION 1

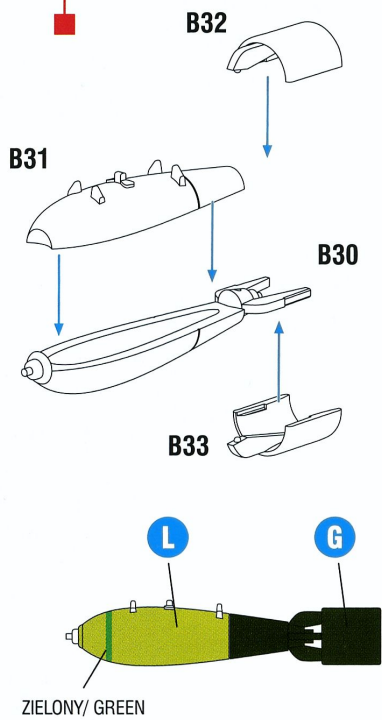

37

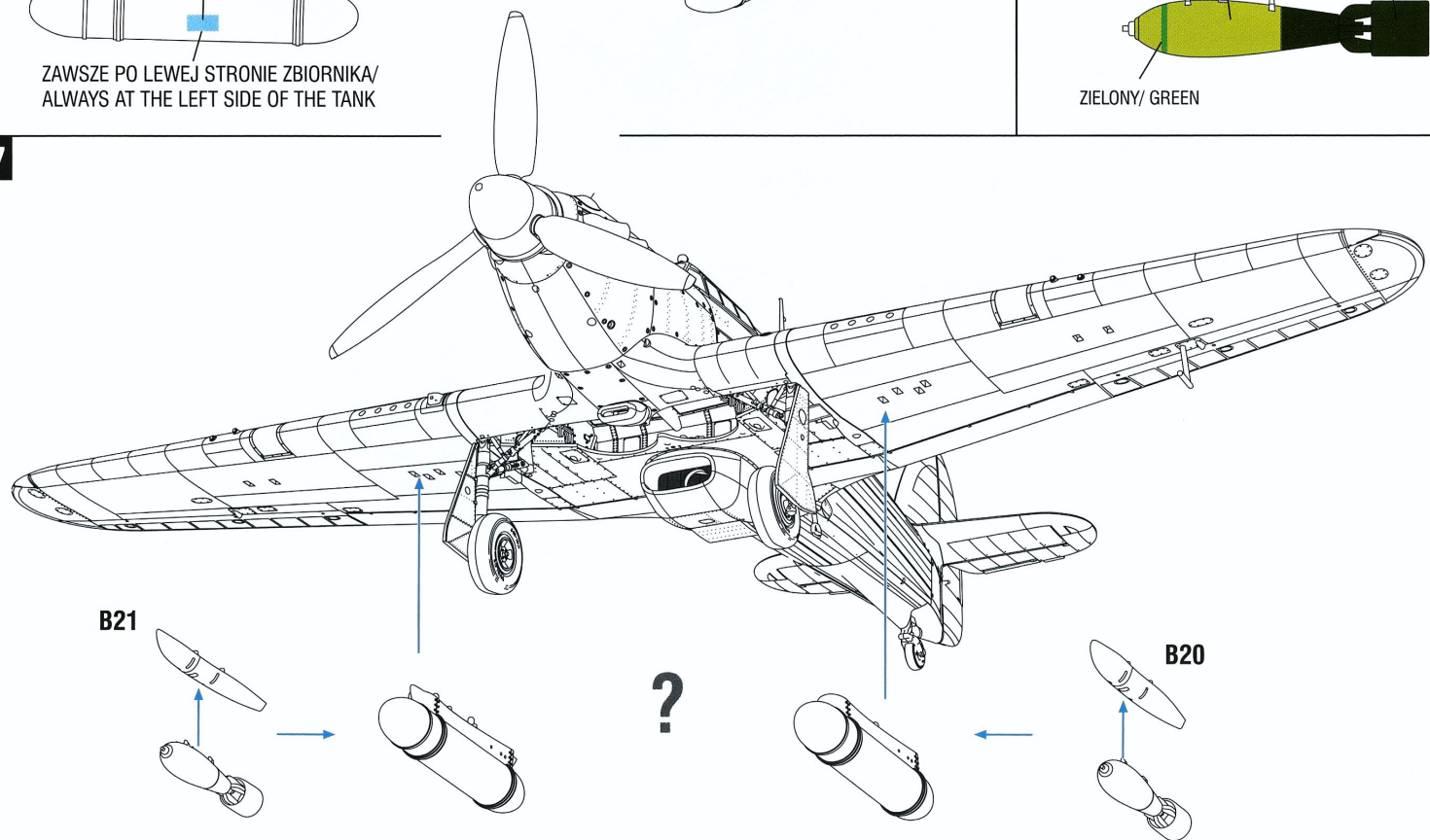

1.

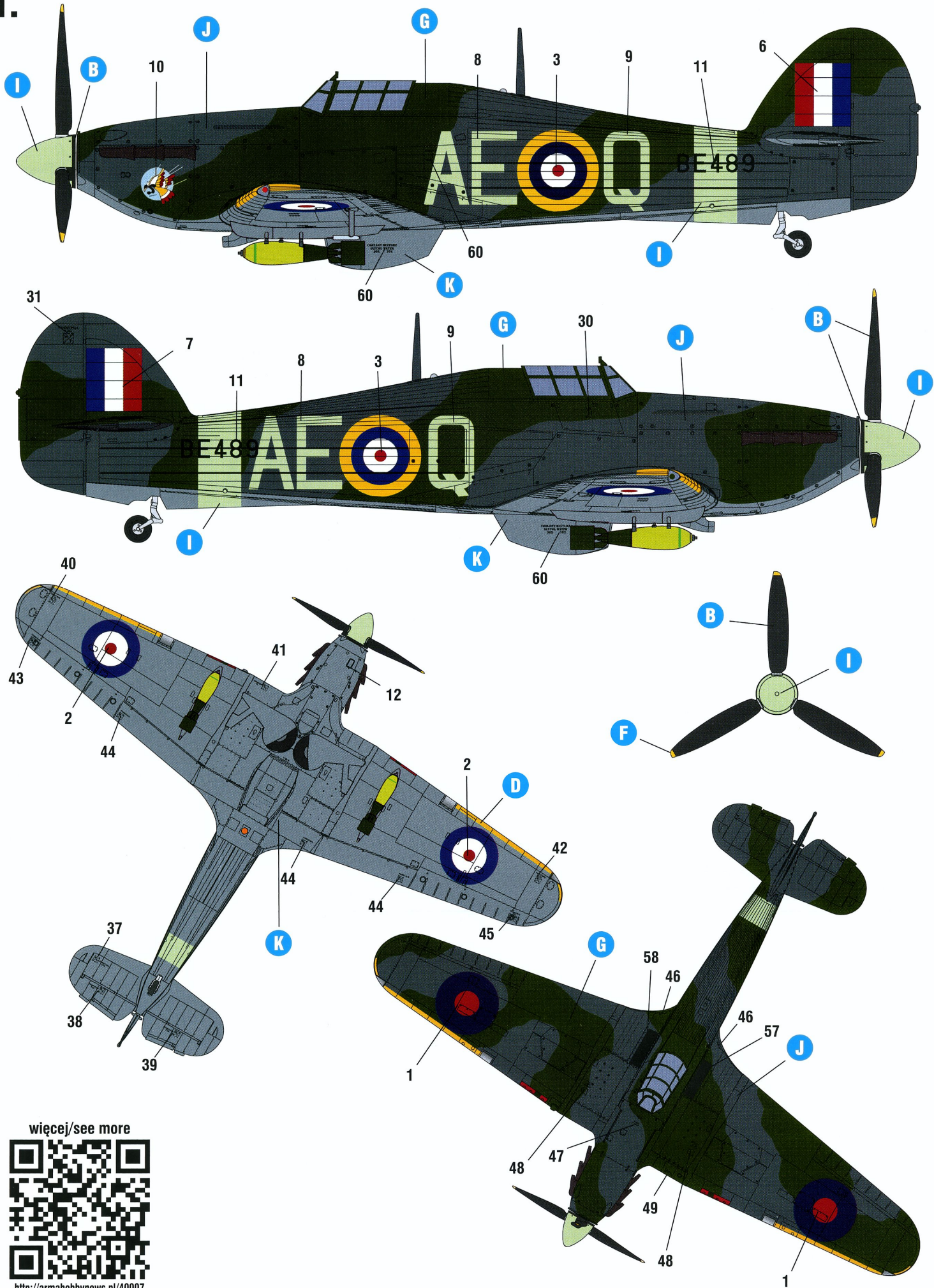

więcej/see more



<http://armahobbynews.pl/40007>

Hurricane Mk.IIb "Hurribomber", BE489/AE-Q "Butch the Falcon", 402 Sqn RCAF, Warmwell, luty 1942 r.
Hurricane Mk.IIb "Hurribomber", BE489/AE-Q "Butch the Falcon", 402 Sqn RCAF, Warmwell, February 1942.

2.

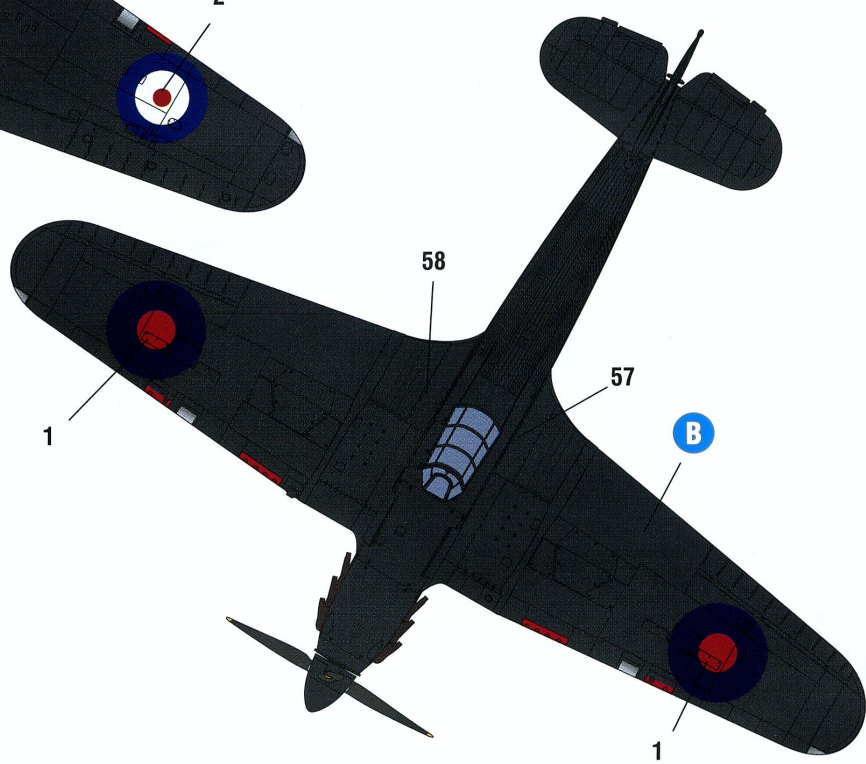
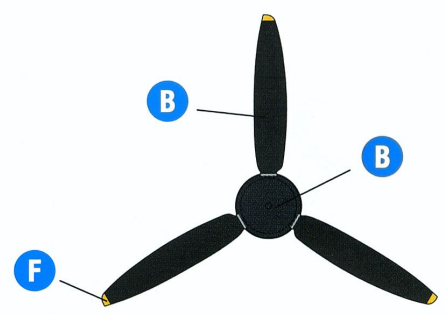
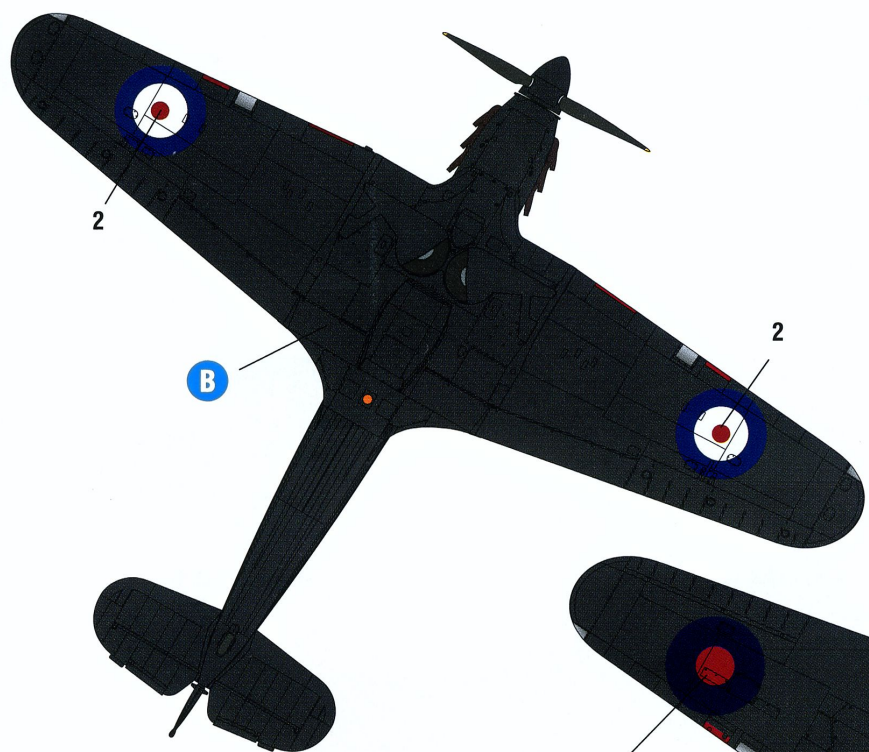
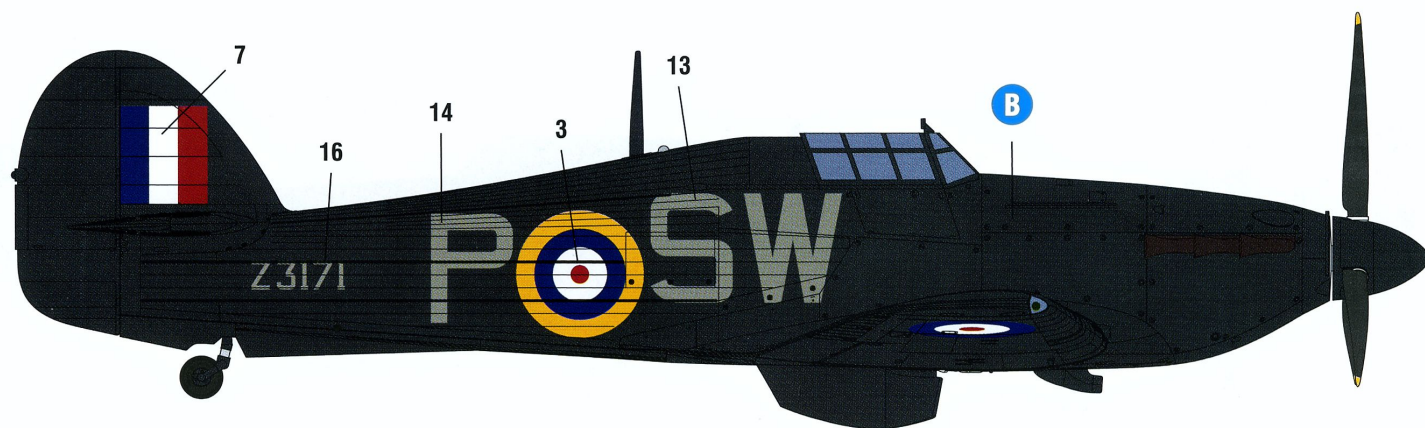
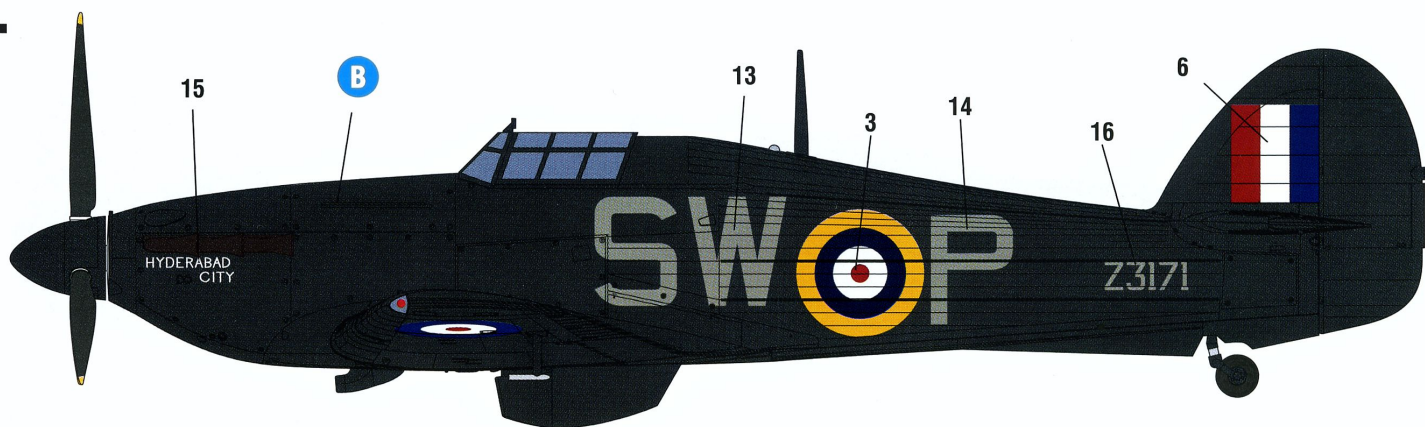

więcej/see more



<http://armahobbynews.pl/40007>

Hurricane Mk.IIb Z3171/SW-P "Hyderabad City", 253 Dywizjon RAF, Hibaldstow, pilot F/SGT. J.C. Tate, zima 1941/42 r.
Hurricane Mk.IIb Z3171/SW-P "Hyderabad City", 253 Squadron RAF, Hibaldstow, pilot F/SGT. J.C. Tate, winter 1941/42.

3.

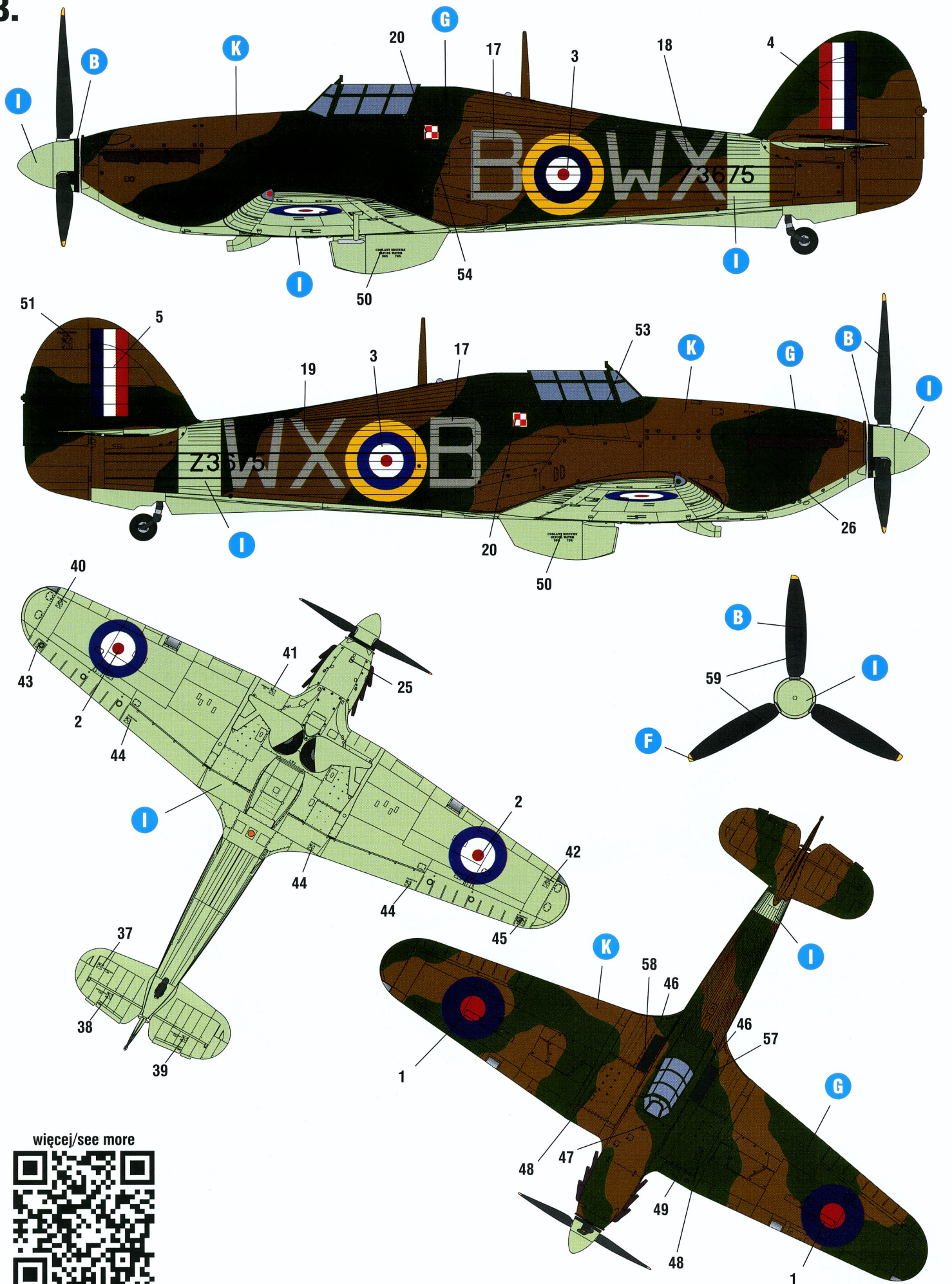

więcej/see more



<http://armahobbynews.pl/40007>

Hurricane Mk. IIb, Z3675/WX-B, 302 Dywizjon PSP, Church Stanton, sierpień 1941 r.
Hurricane Mk. IIb, Z3675/WX-B, 302 Squadron PAF, Church Stanton, August 1941.