



Dassault RAFALE M bomb & rack

04517-0389

© 2012 BY REVELL GmbH & Co. KG. A subsidiary of Hobbico, Inc.

PRINTED IN GERMANY



Dassault RAFALE M bomb & rack

Im Jahr 1978 startete bei Dassault das ACX-Programm (eXperimental Combat Aircraft) für die Entwicklung eines höchst effektiven Mehr-Zweck-Kampfflugzeugs, versehen mit neuester Technologie und inklusive der Fähigkeit, auf einem Flugzeugträger starten und landen zu können. Es sollte alle damals eingesetzten Kampfflugzeuge ersetzen. Am 4. Juli 1986 startete der Rafale A Prototyp zu seinem Jungfernflug vom Test Zentrum der Airbase 125 Istres. Zu diesem Zeitpunkt war der Prototyp mit F404 Triebwerken ausgestattet, die auch in die F/A-18 installiert waren. Die Test- und Erprobungsflüge für die Rafale Prototypen begannen im Januar 1988. Diese Maschinen bestanden aus einer Rafale C, einer Rafale B (Zweisitzer) und zwei modifizierten Rafale M für den Flugzeugträgerinsatz, die erstmalig am 12. Dezember 1991 flogen. Diese Versionen unterscheiden sich deutlich von der anfänglichen Rafale A-Version. So sind Kohlefaserverbundstoffe für den Zellenaufbau verwendet worden, die Rafale wurde kompakter und hat ein geringeres Gewicht. Die Rafale ist dann auch mit den leistungsstärkeren Snecma M88 Triebwerken ausgerüstet worden. Auch die Flugzeugzelle ist optimiert worden um die Radarsignatur zu reduzieren. Die Rafale wurde in drei Stufen (Version F1, F2 und F3) entwickelt. Die zuerst eingesetzte Rafale ist die Rafale M F1 bei der Flottille 12F in 2001. Es handelt sich um ein reines Kampfflugzeug, ausgerüstet mit Luft-Luft-Lenk Waffen und Bordkanonen. Die F2-Version (Jagdbomber) wurde im Jahre 2005 an die französische Luftwaffe und die Marine ausgeliefert. Die Auslieferung der Mehrzweck-Version F3 begann im Jahre 2009 nach umfangreichen Änderungen. Die Rafale kann viele Missionsprofile erfüllen, einschließlich der Luftüberlegenheitsrolle, taktische Unterstützung, den Einsatz mit lasergelenkten Bomben, Marschflugkörperabwurf, Angriff auf Seeziele, Aufklärung und auch Luft-Luft-Betankung. Diese Eigenschaften machen die Rafale zu einem ernsthaften Konkurrenten für die JAS-39 Gripen, den Eurofighter Typhoon und die F/A-18E/F Super Hornet. Die F4-Version ist derzeit noch in der Projektphase, sie wird mehr Stealth-Eigenschaften besitzen, mit einem stärkeren Aktiv-Radar ausgerüstet sein und in der Lage sein, Langstrecken Luft-Luft-Lenk Waffen abzuwerfen. Damit könnte sie ein ernsthafter Konkurrent für die F-22 und F-35 werden. Im Juni 2010 feierten die Französischen Marine Flieger ihr 100 Jahre-Jubiläum. Die Rafale M spielte dabei eine wichtige Rolle. Die Flottille 11F, die bislang die modernisierte Super-Etendard (SEM) benutzte, rüstete im Februar 2012 auf die Rafale M um. Die Flottille 17F, die die SEM immer noch fliegt wird zukünftig auch auf Rafale M umstellen. Beide Flottillen sind auf der Marine Luftwaffen Basis in Landivisiau, Bretagne, stationiert. Die Flugzeuge werden regelmäßig an Bord des Flugzeugträgers Charles-De-Gaulle eingesetzt und um stationiert. Sie wurden bereits bei vielen großen Konflikten während den letzten Jahren eingesetzt, insbesondere in Afghanistan während der Operation Heracles, und in Libyen während der Operation Harmattan.

Rafale M Technische Daten:

Spannweite:	10,90m	Länge:	15,30m
Höhe:	5,34m	Leergewicht:	9670 kg
Gewicht max:	24500 kg	Maximale Waffenzuladung:	8000 kg
Treibstoff max:	4800 kg (intern) plus 6800 kg (extern)		
Triebwerke:	2x M88-2 (2x 48,7kN – 72,9kN mit Nachbrenner)		
Geschwindigkeit max:	2200 km/h (Mach 1,8)		
Dienstgipfelhöhe:	16800m (55000ft)		
Steigleistung max:	18000m/min		
Reichweite:	1090 km (Bodennähe) – 1850 km (in großer Höhe)		
Bord Bewaffnung:	1 x 30 mm Giat DEFA 791B Kanone		
Externe Bewaffnung:	Mica-IR Infra-Red Luft-Luft-Lenk Waffe Mica-EM Elektromagnetische Luft-Luft-Lenk Waffe Mk82 / Mk83 / Mk84 Bomben Laser/GPS GBU-12 / GBU-24 / AASM Lenkbomben Apache / SCALP-EG / ASMP-A (nuklear) Marschflugkörper Exocet AM39 B2 Anti-Schiffs-Lenk Waffe Reco-NG Aufklärungspod Douglas Luft-Luft Betankungspod		

Dassault RAFALE M bomb & rack

In 1978 Dassault started the ACX program (eXperimental Combat Aircraft) for a highly successful multi-role combat aircraft incorporating the the latest technology including the ability to operate from an aircraft carrier. It would replace all combat aircraft currently in service. On 4th July 1986 the Rafale A demonstrator prototype took off on its maiden flight from the Flight Test Centre at Airbase 125 Istres. At this time it was fitted with the American manufactured F404 engines which also powered the F/A-18. Air-testing and proving for the Rafale prototypes commenced in January 1988. This consisted of one Rafale C, one Rafale B (two-seater) and two Rafale M modified for carrier operation which flew for the first time on 12th December 1991. This version differs significantly from the Rafale A demonstrator. Composite materials are used in its construction, it is smaller in size and has a lower weight. It is fitted with the more powerful Snecma M88 engines. The design is also optimized to reduce the radar signature. The Rafale was developed in three stages (versions F1, F2 and F3). The first Rafale to enter service was the Rafale M version F1 with Flotilla 12F in the year 2001. It is a pure fighter equipped only with air-to-air missiles and cannon. The F2 version (fighter-bomber) was delivered to the Air Force and the Navy in 2005. After on-going modification delivery of the multi-role F3 version commenced in 2009. It can undertake many mission profiles including Air Superiority, Tactical Support, Guided or non-guided Bombing, Cruise Missiles launch, Anti-Shipping Attack, Reconnaissance and also Air to Air Refuelling using the Douglas refuelling pod. These attributes make the Rafale a serious competitor to the Saab JAS-39 Gripen, Eurofighter and F/A-18E/F Super Hornet. The F4 version is currently still in the project stage, it will have more stealth, be equipped with a more powerful active radar and be capable of launching long range Air-to-Air missiles. It could be a competitor against the American F-22 and F-35. French Naval Aviation celebrated its 100th anniversary in June 2010 and the Rafale M played an important role in the festivities. The Rafale M has been in service with the Flotilla 12F since 2001. Flotilla 11F which was operating the Modernized Super-Etendard (SEM) has been converting to Rafale M since February 2012. In the future Flotilla 17F which is still flying the SEM will also convert to the Rafale M. Both these Flottillas are stationed at the Landivisiau Naval Air Base in Brittany. Aircraft are regularly embarked on the aircraft carrier R91 Charles-De-Gaulle and have already taken part in major conflicts over the last few years, in particular over Afghanistan on Operation Heracles, and in Libya during Operation Harmattan.

Rafale M Technical Data:

Wingspan:	10,90m
Length:	15,30m
Height:	5,34m
Empty Weight:	9670 kg
Maximum Weight:	24500 kg
Maximum Fuel Capacity:	4800 kg (internal) + 6800 kg (external)
Maximum Armament Load:	8000 kg
Engines:	2x M88-2 (2x 48,7kN – 72,9kN with after-burner)
Maximum Speed:	2200 km/h (Mach 1,8)
Service Ceiling:	16800m (55000ft)
Maximum Rate of Climb:	18000m/min
Range:	1090 km (Low level) – 1850 km (High Altitude)
Internal Armament:	1 x 30 mm Giat DEFA 791B Cannon
External Weapons:	Mica-IR Infra-Red (Air-to-Air) Missile Mica-EM Electro-Magnetic (Air-to-Air) Missile Mk82 / Mk83 / Mk84 Unguided Bombs Laser/GPS Guided GBU-12 / GBU-24 / AASM Bombs Apache / SCALP-EG / ASMP-A (nuclear) Cruise Missiles ExocetAM39 B2 Anti-Ship Missile Reco-NG Reconnaissance Pod Douglas Air to Air Refuelling Pod

Forst hergestellt und im Eigentum von Revell GmbH & Co. KG. Weitere rechtliche Nachahmungen werden gerichtlich verfolgt.
Ce produit est propriété de la société Revell GmbH & Co. KG. Toute utilisation ou duplication frauduleuse fera l'objet de poursuites en justice.
Modelado y en propiedad de Revell GmbH & Co. KG. Imitaciones ilícitas serán perseguidas por la ley.
Forma prodotta da la Revell GmbH & Co. KG. e di proprietà della stessa impresa, la quale procederà legalmente contro ogni imitazione abusiva.
Modell von Revell GmbH & Co. KG. valmistama ja omisuvatus. Laittooman kopioitumin tuullaan puuttumaan oikeudellisiin toimin.
Formen er produsert og eies av Revell GmbH & Co. KG. Etterligning uten tillatelse vil bli gjerdet for rettslig forfølgelse.
Produkcja i prawa własności firmy Revell GmbH & Co. KG. Niezgodne podrobienie jest zabronione pod odpowiedzialnością sądową.
Model Revell GmbH & Co. KG. firmasının mülkiyeti altında imal edilmiştir. Kanuna aykırı taklitler mahkemeye takip edilecektir.
A forma előállításja és a tulajdonjog ártózkosa a Revell GmbH & Co. KG. A jogellenes utánzatokat és hamisítványokat bírósági útra fogjuk, üldözni.

Mould manufactured by and property of Revell GmbH & Co. KG. Legal imitations are subject to prosecution.
Vorm versvaardigd door en eigendom van Revell GmbH & Co. KG. Onrechtmatige nabootsingen worden gerechtelijk vervolgd.
Formas produzidas e de propriedade da Revell GmbH & Co. KG. Cópias não autorizadas serão processadas, unicamente como determinados na lei.
Modellen tillverkad av och tillhör Revell GmbH & Co. KG. All kopiering beivras enligt lagen om upphovsrätt.
Formen er framstillet af Revell GmbH & Co. KG. som også har ejendomsret. Læstriblige efterligninger søgtes.
Modela proizvedena i vlasnosti Revell GmbH & Co. KG. Proneizvodzheniya videlnykh predstavlyayutsya v sudobnoye postupki.
- modeler katodokovoditoren van revell'is etny iobstoytvo tye Revell GmbH & Co. KG. Si parovozmet imitatsiya vo katozhivkovaya diskvalifikatsiya.
Tez byl vysoyten lirnet Revell GmbH & Co. KG. e g'zlyo vlastnichivni. Prsh nezakonnym napodobleniyem se bude postuzoval suazny veslau.
Forma je proizvedena in je vlasništvo Revell GmbH & Co. KG. Neovobdane kopije bodo pravno kaznjene.

Benötigte Farben / Used Colors

Benötigte Farben
Required colours

Peintures nécessaires
Benodigde kleuren

Pinturas necesarias
Tintas necessárias

Colori necessari
Använda färger

Tarvittavat värit
Du trenger følgende farger

Nødvendige farger
Необходимые краски

Potrebne kolory
Απαιτούμενα χρώματα

Gerekli renkler
Potřebné barvy

Szükséges színek
Potrebne barve

A

anthrazit, matt 9
anthracite grey, matt
anthracite, mat
antracit, mat
antracita, mate
antracite, fosco
antracite, opaco
antracit, matt
antrasiti, himmeä
koksgrå, mat
antrasitt, matt
антрацит, матовый
антрацит, матовый
ανθρακί, ματ
antrasit, mat
antrasit, matná
antracit, matt
tamno siva, matt

B

aluminium, metallic 99
aluminium, metallic
aluminium, métallique
aluminium, metallic
aluminio, metalizado
aluminio, metalico
aluminio, metalico
aluminium, metallic
aluminium, metallic
alumiini, metallikiito
aluminium, metallak
aluminium, metallic
алюминиевый, металллик
aluminium, metaliczny
αλουμίνιο, μεταλλικό
aluminium, metallak
aluminium, metallak
aluminium, metallak
aluminium, metallak

C

schwarz, seidenmatt 302
black, silky-matt
noir, satiné mat
zwart, zijdemat
negro, mate seda
preto, fosco sedoso
nero, opaco seta
svart, sidenmatt
musta, silkinhimmeä
sort, silkematt
sort, silkematt
черный, шелковисто-матовый
czarny, jedwabisto-matowy
μαύρο, μεταξωτό ματ
siyah, ipek mat
černá, hedvábně matná
fekete, selyemmatt
črna, svila mat

D

eisen, metallic 91
steel, metallic
coloris fer, métallique
ijzerkleurig, metallic
ferroso, metalizado
ferro, metalico
ferro, metalico
järnfärg, metallic
teräksenväriäinen, metallikiito
jern, metallak
jern, metallic
стальной, металллик
želazo, metaliczny
σίδηρου, μεταλλικό
demir, metallak
železná, metaliza
vas, metallak
železna, metallak

E

teerswarz, matt 6
tar black, matt
noir tartre, mat
teerzwart, mat
negro alquitrán, mate
alcitrão, fosco
nero catrame, opaco
asfaltsvart, matt
tervanmusta, himmeä
tjæresort, matt
tjæresort, matt
смолисто-черный, матовый
czarny-smola, matowy
μαύρο πίσσας, ματ
katran siyah, mat
dehtové černá, matná
kátrányfekete, matt
ter črna, mat

F

mausgrau, matt 47
mouse grey, matt
gris souris, mat
muisgrjs, mat
gris ratón, mate
cinzento pardo, fosco
grigio topo, opaco
musgrå, mat
hiirenharmaa, himmeä
musegrå, mat
musegrå, mat
мышино-серый, матовый
myszaty, matowy
γκρι ποπτικίου, ματ
fare gris, mat
mysi šedá, matná
egérszürke, matt
mišje siva, mat

G

laubgrün, seidenmatt 364
leaf green, silky-matt
vert feuille, satiné mat
bladgrøen, zijdemat
verde follaje, mate seda
verde gaio, fosco sedoso
verde foglia, opaco seta
lövgrön, sidenmatt
lehdenvihreä, silkinhimmeä
lövgrön, silkematt
lövgrön, silkematt
лиственно-зеленый, шелк.-матовый
zielony liściasty, jedwabisto-matowy
πράσινο φυλλωμάτων, μεταξ, ματ
yaprak yeşili, ipek mat
zelená jako listí, hedvábně matná
lombzöld, selyemmatt
list zelena, svila mat

H

Blau, klar 752
Blue, clear
Bleu, transparent
Blauw, transparent
Azul, transparente
Azul, claro
Blu, trasparente
Blå, klar
Sininen, kirkas
Blå, klar
Blå, klar
Синий, прозрачный
zielony przejrzysty
Μπλε, καθαρό
Mavi, açık
Kék, átlátszó
Modrá, jasná
Modra, prozorna

70 %

I

eisen, metallic 91 +
steel, metallic
coloris fer, métallique
ijzerkleurig, metallic
ferroso, metalizado
ferro, metalico
ferro, metalico
järnfärg, metallic
teräksenväriäinen, metallikiito
jern, metallak
jern, metallic
стальной, металллик
želazo, metaliczny
σίδηρου, μεταλλικό
demir, metallak
železná, metaliza
vas, metallak
železna, metallak

30 %

anthrazit, matt 9
anthracite grey, matt
anthracite, mat
antracit, mat
antracita, mate
antracite, fosco
antracite, opaco
antracit, matt
antrasiti, himmeä
koksgrå, mat
antrasitt, matt
антрацит, матовый
антрацит, матовый
ανθρακί, ματ
antrasit, mat
antrasit, matná
antracit, matt
tamno siva, mat

95 %

J

farbløs, glänzend 1
clear, gloss
incoloro, brillant
kleurloos, glansend
incoloro, brillante
incolor, brillante
trasparente, lucente
färglös, blank
värifön, killtävä
farvelos, skinnende
klar, blank
бесцветный, блестящий
bezbawny, błyszczący
άχρωμο, υαλοστερό
renkisz, parlak
bezbarevná, lesklá
szintelen, fényes
brezbravna, bleskajoča

5 %

seegrün, matt 48
sea green, matt
vert d'eau, mat
zeegroen, mat
verde mar, mate
verde-mar, fosco
verde lago, opaco
havsgrün, matt
merenvihreä, himmeä
havgrøn, mat
sjøgrøn, matt
зеленый морской, матовый
zielon morską, matowy
πράσινο λίμνης, ματ
göl yeşili, mat
mořská zelená, matná
tengerzöld, matt
morsko zelena, mat

K

rot, klar 731
red, clear
rouge, clair
rood, helder
rojo, claro
vermelho, claro
rosso, chiaro
röd, klar
punainen, kirkas
röd
красный
czewień
κόκκινο, διαυγές
kirmizi, şeffaf
červená, čirá
piros, áttetsző
rdeča, jasna

L

hellgrau, seidenmatt 371
light grey, silky-matt
gris clair, satiné mat
lichtgrjs, zijdemat
gris claro, mate seda
cinzento claro, fosco sedoso
grigio chiaro, opaco seta
ljusgrå, sidenmatt
vaaleanharmaa, silkinhimmeä
lysegrå, silkematt
lysgrå, silkematt
светло-серый, шелковисто-матовый
jasnoszary, jedwabisto-matowy
ανοιχτό γκρι, μεταξωτό ματ
açık gri, ipek mat
světlešedá, hedvábně matná
világosszürke, selyemmatt
sveto siva, svila mat

80 %

M

grau, seidenmatt 374 +
grey, silky-matt
gris, satiné mat
grjs, zijdemat
gris, mate seda
cinzento, fosco sedoso
grigio, opaco seta
grå, sidenmatt
harmaa, silkinhimmeä
grå, silkematt
grå, silkematt
серый, шелковисто-матовый
szary, jedwabisto-matowy
γκρι, μεταξωτό ματ
gri, ipek mat
šedá, hedvábně matná
szürke, selyemmatt
siva, svila mat

20 %

blaugrau, matt 79
greyish blue, matt
gris-bleu, mat
blauwgrjs, mat
gris azulado, mate
cinzento azulado, fosco
grigio blu, opaco
blågrå, matt
siniharmaa, himmeä
blågrå, matt
blågrå, matt
сине-серый, матовый
siwy, matowy
γκριζομπλέ, ματ
mavi gri, mat
modrošedá, matná
kékesszürke, matt
plavo siva, mat

N

dunkelgrau, seidenmatt 378
dark grey, silky-matt
gris foncé, satiné mat
donkergrjs, zijdemat
gris oscuro, mate seda
cinzento escuro, fosco sedoso
grigio scuro, opaco seta
mörkgrå, sidenmatt
harmaa, silkinhimmeä
markgrå, silkematt
markgrå, silkematt
серый, шелковисто-матовый
szary, jedwabisto-matowy
γκρι, μεταξωτό ματ
gri, ipek mat
šedá, hedvábně matná
szürke, selyemmatt
siva, svila mat

O

weiß, seidenmatt 301
white, silky-matt
blanc, satiné mat
wit, zijdemat
blanco, mate seda
branco, fosco sedoso
bianco, opaco seta
vit, sidenmatt
valkoinen, silkinhimmeä
hvid, silkematt
hvit, silkematt
белый, шелковисто-матовый
biały, jedwabisto-matowy
λευκό, μεταξωτό ματ
beyaz, ipek mat
biłá, hedvábně matná
fehér, selyemmatt
beła, svila mat

P

silber, metallic 90
silver, metallic
argent, métallique
zilver, metallic
plata, metalizado
prata, metalico
argento, metalico
silver, metallic
hopea, metallikiito
solv, metallak
solv, metallic
серебристый, металллик
srebro, metaliczny
οσμή, μεταλλικό
gümüş, metallak
stříbrná, metaliza
ezüst, metallak
srebrna, metallak

90 %

Q

lichtblau, glänzend 50 +
light blue, gloss
bleu clair, brillant
lichtblauw, glansend
azul celeste, brillante
azul celeste, brillante
blu celeste, lucente
ljusblå, blank
vaaleansininen, killtävä
lysende blå, skinnende
lyseblå, blank
голубой, блестящий
jasnoniebieski, błyszczący
μπλε φωτός, υαλοστερό
ışık mavisi, parlak
světlemodrá, lesklá
világító kék, fényes
svetlo plava, bleskajoča

10 %

blau, matt 56
bleu, matt
bleu, mat
blauw, mat
azul, mate
azul, fosco
blu, opaco
blå, matt
sininen, himmeä
blå, mat
blå, matt
синий, матовый
niebieski, matowy
μπλε, ματ
mavi, mat
modrá, matná
kék, matt
plava, mat

R

rost, matt 83
rust, matt
rouille, mat
roest, mat
orin, mate
ferrugem, fosco
color ruggine, opaco
rost, matt
ruoste, himmeä
rust, mat
rust, matt
ржавчина, матовый
rózawy, matowy
χρώμα σκουριάς, ματ
pas rengi, mat
rezavá, matná
rozsdá, matt
řjava, mat

S

olivgrün, seidenmatt 361
olive green, silky-matt
vert olive, satiné mat
oijlgrøen, zijdemat
verde aceituna, mate seda
verde azeitona, fosco sedoso
verde oliva, opaco seta
olivgrön, sidenmatt
olivinvihreä, silkinhimmeä
olivgrön, silkematt
olivengrön, silkematt
зеленый оливковый, шелк.-матовый
oliwkowy, jedwabisto-matowy
πράσινο ελιάς, μεταξωτό ματ
zeytin yeşili, ipek mat
olivové zelená, hedvábně matná
olivzöld, selyemmatt
oliva zelena, svila mat

T

dunkelgrün, seidenmatt 363
dark green, silky-matt
vert foncé, satiné mat
donkergroen, zijdemat
verde oscuro, mate seda
verde escuro, fosco sedoso
verde scuro, opaco seta
mörkgrön, sidenmatt
tummanvihreä, silkinhimmeä
markgrön, silkematt
markgrön, silkematt
темно-зеленый, шелк.-матовый
ciemnozielony, jedwabisto-matowy
σκοуро πράσινο, μεταξωτό ματ
koyu yeşil, ipek mat
tmavozelená, hedvábně matná
sötétzöld, selyemmatt
temno zelena, svila mat

U

beige, seidenmatt 314
beige, silky-matt
beige, satiné mat
beige, zijdemat
beige, mate seda
beige, fosco sedoso
beige, opaco seta
beige, sidenmatt
beige, silkinhimmeä
beige, silkematt
beige, silkematt
бежевый, шелковисто-матовый
beżowy, jedwabisto-matowy
μπες, μεταξωτό ματ
bej, ipek mat
béžová, hedvábně matná
bézs, selyemmatt
sionova kost, svila mat

V

gold, metallic 94
gold, metallic
or, métallique
goud, metallic
oro, metalizado
ouro, metalico
oro, metalico
guld, metallic
kulta, metallikiito
guld, metallak
guld, metallic
золотой, металллик
złoto, metaliczny
χρυσόφι, μεταλλικό
altın, metallak
zlatá, metaliza
arany, metallak
zlatna, metallak

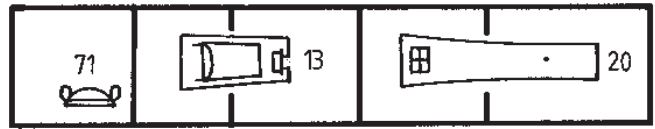
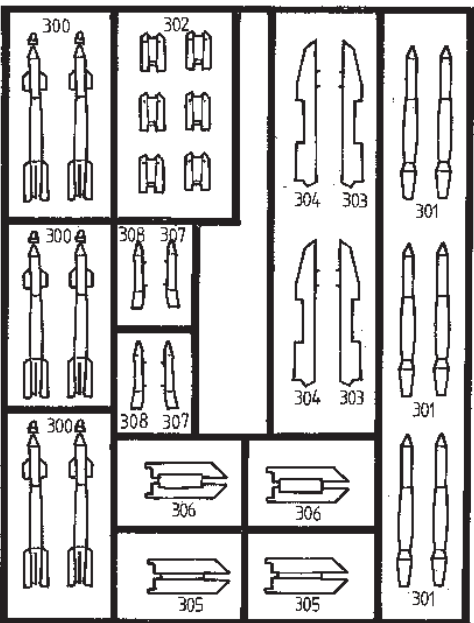
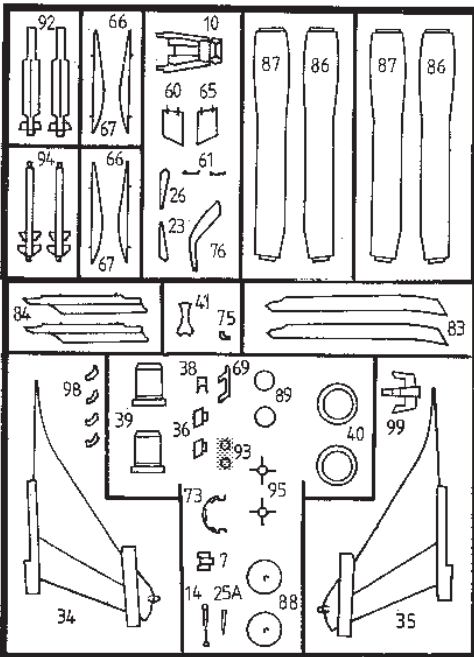
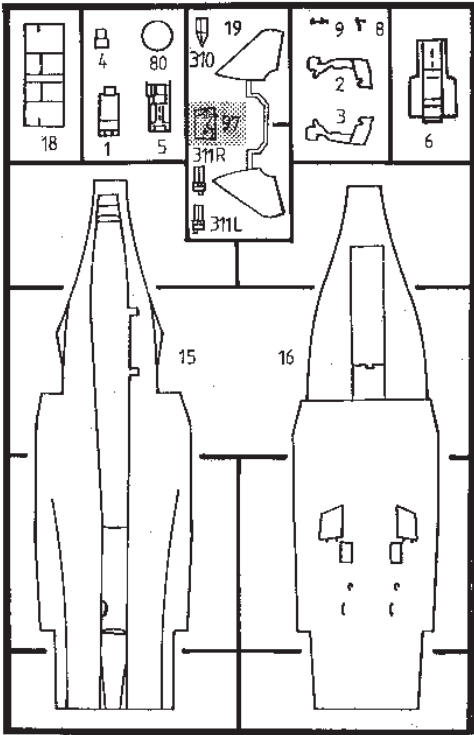

 Nicht benötigte Teile
 Parts not used
 Pièces non utilisées
 Niet benodigde onderdelen
 Piezas no necesarias
 Peças não utilizadas
 Parti non usate
 Inte anvănda delar
 Tarpeettomat osat
 Ikke nødvendige dele
 Deler som ikke er nødvendige
 Неиспользованные детали
 Elementy niepotrzebne
 μη χρειαζόμενα εξαρτήματα
 Gereksiz parçalar
 Nepotrebné díly
 fel nem használt alkatrészek
 Nepotrební deli

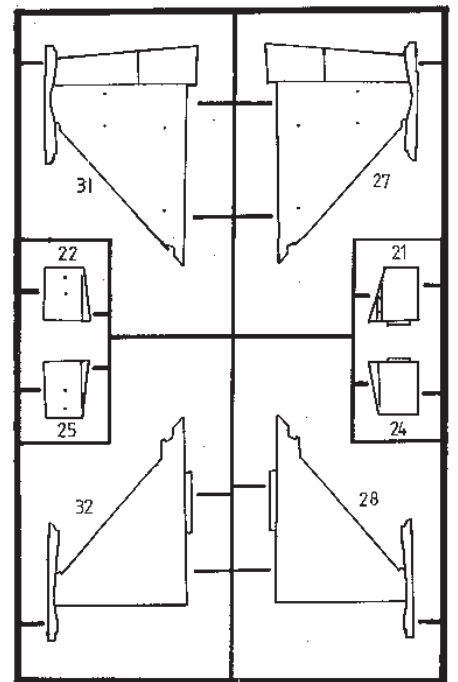
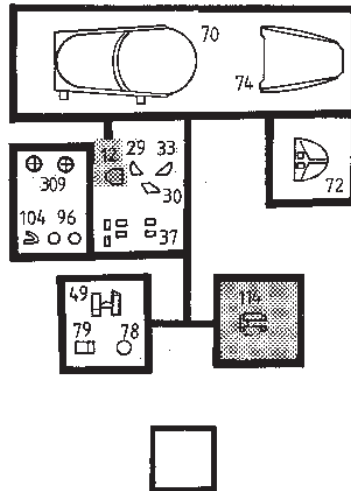
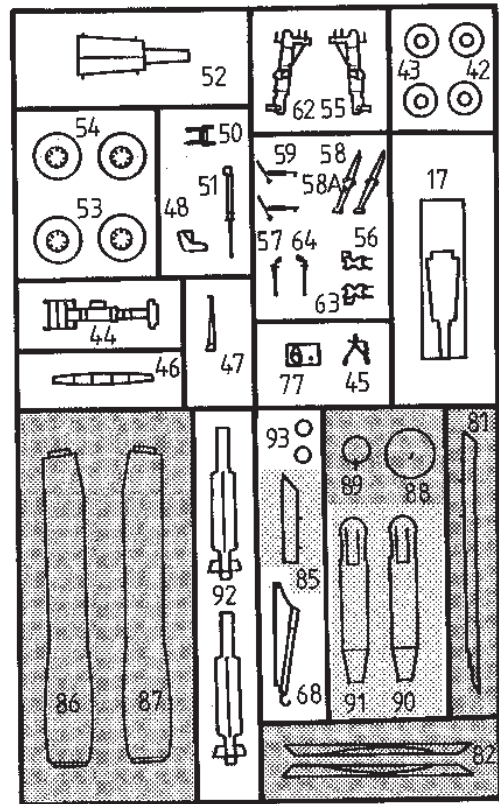

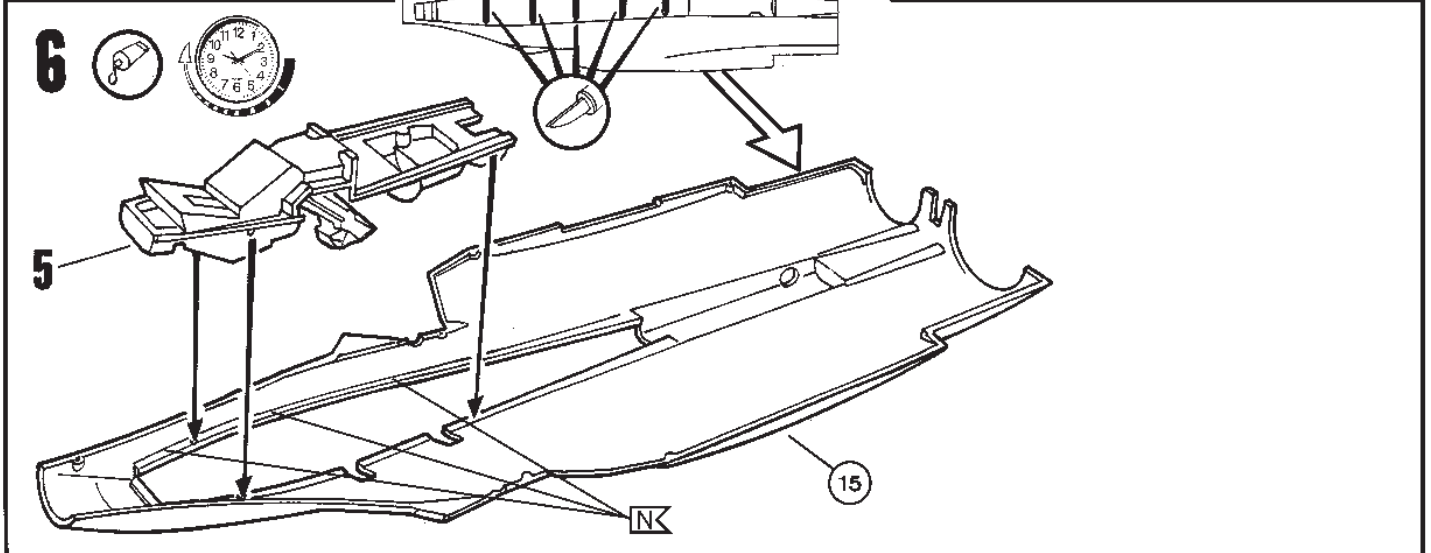
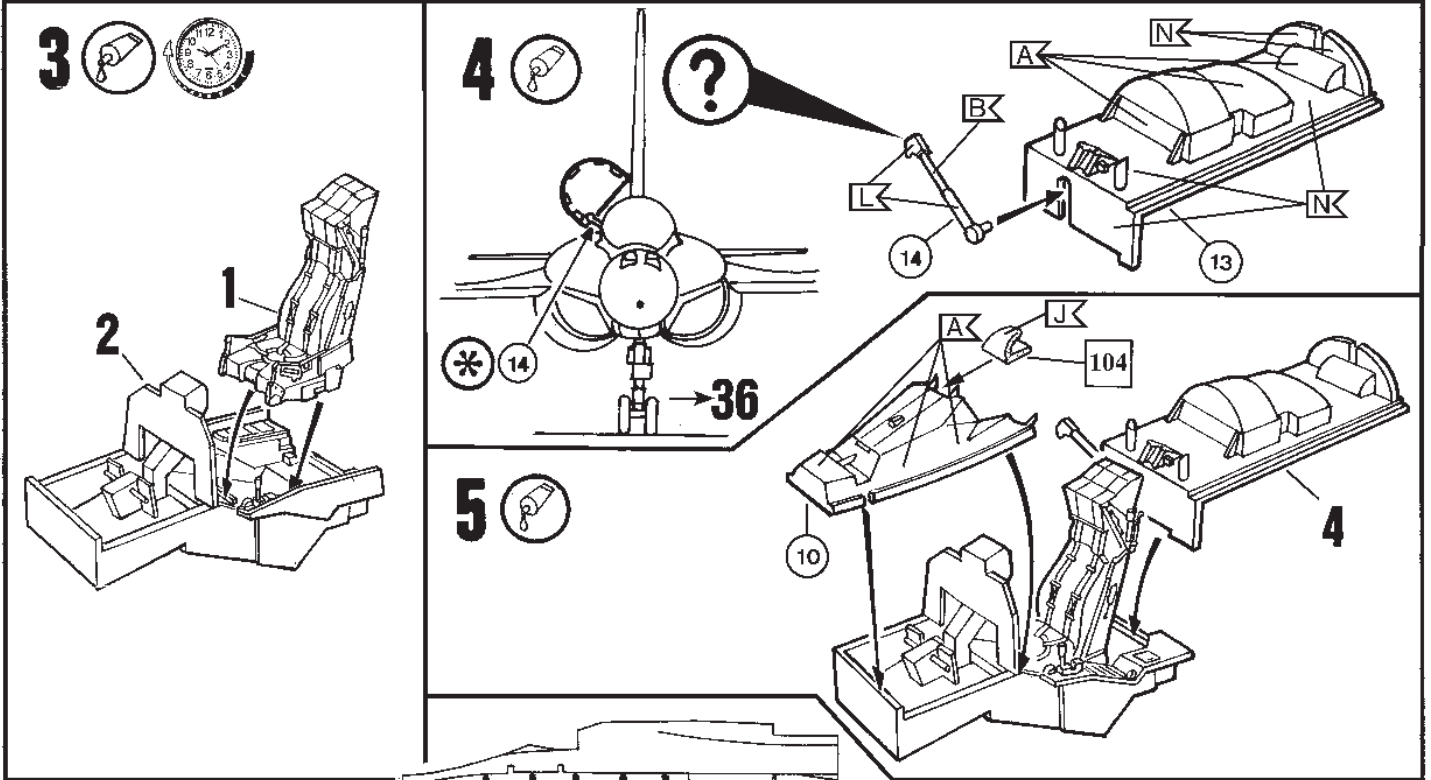
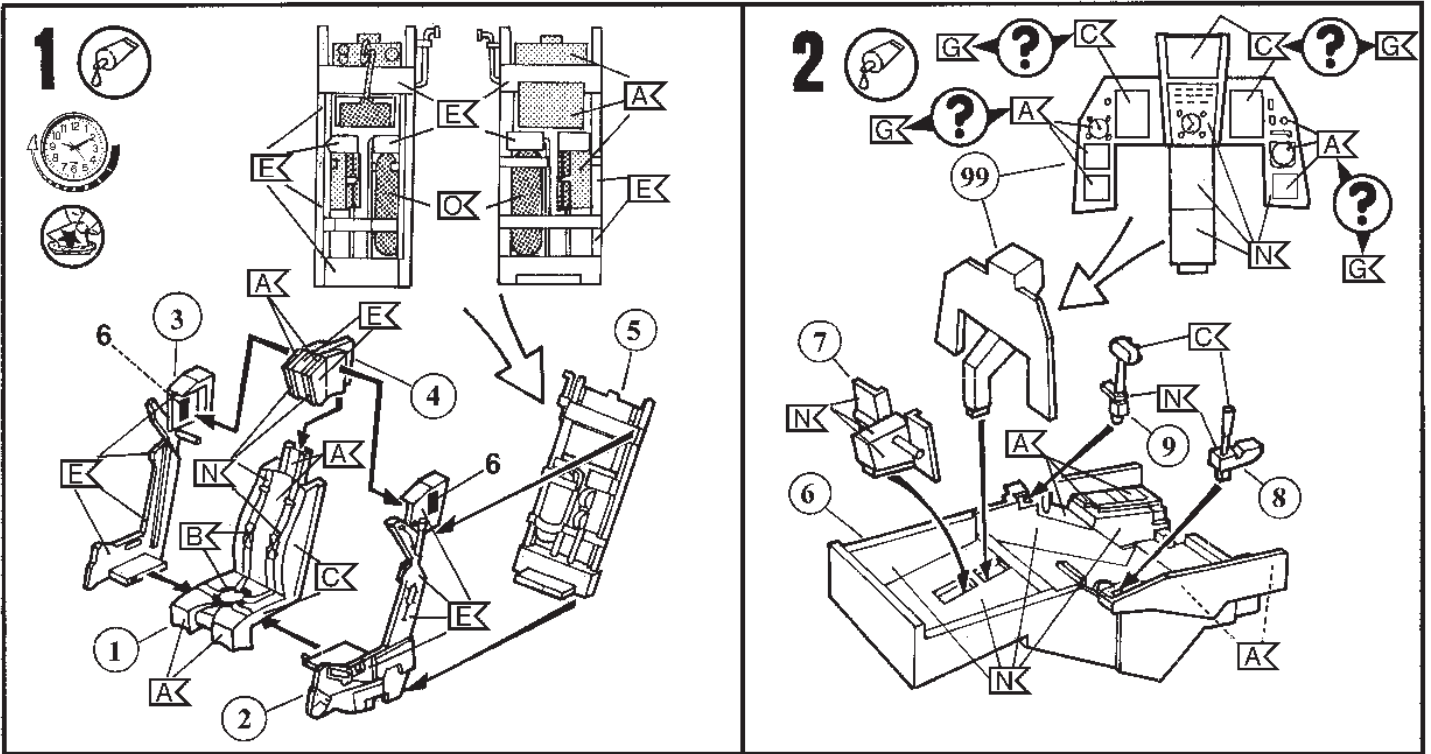

7

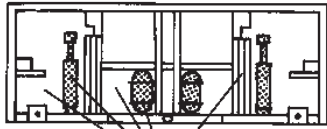

18

16

17

19

8



9

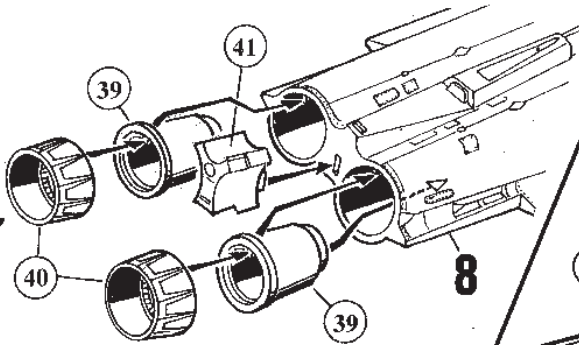
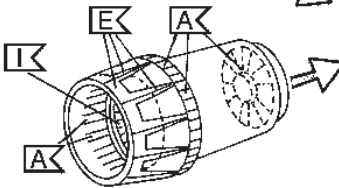

10

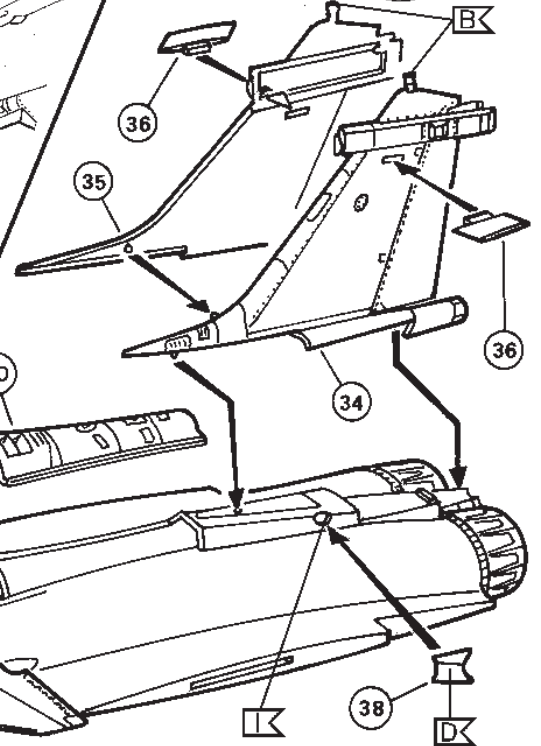

11

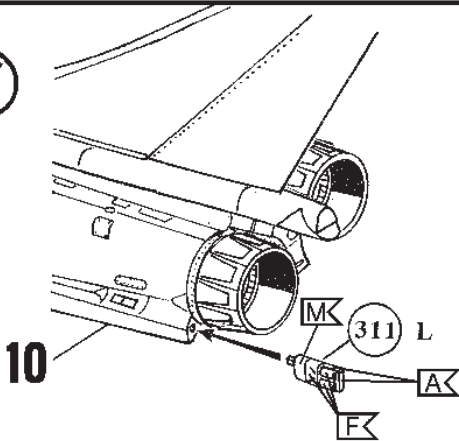

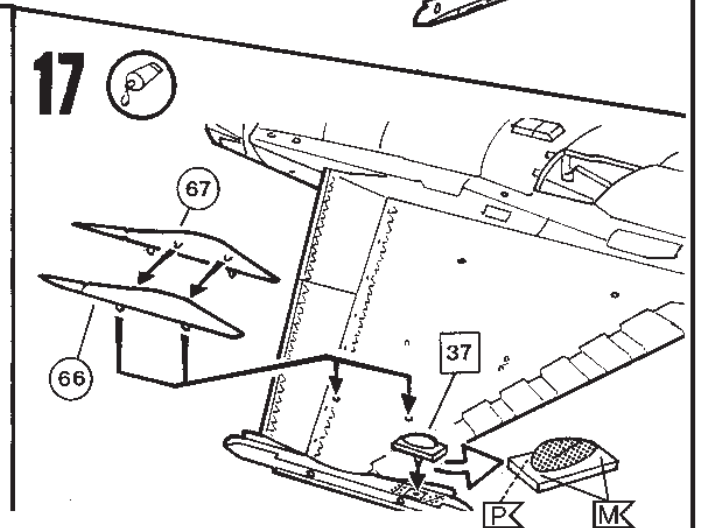
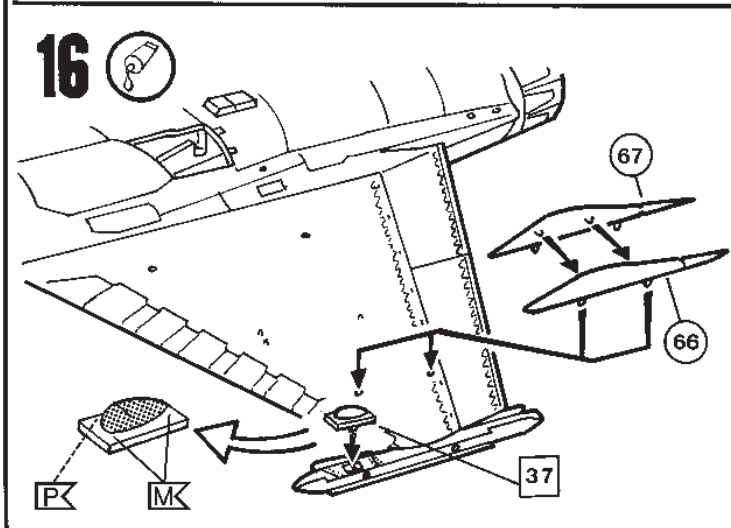
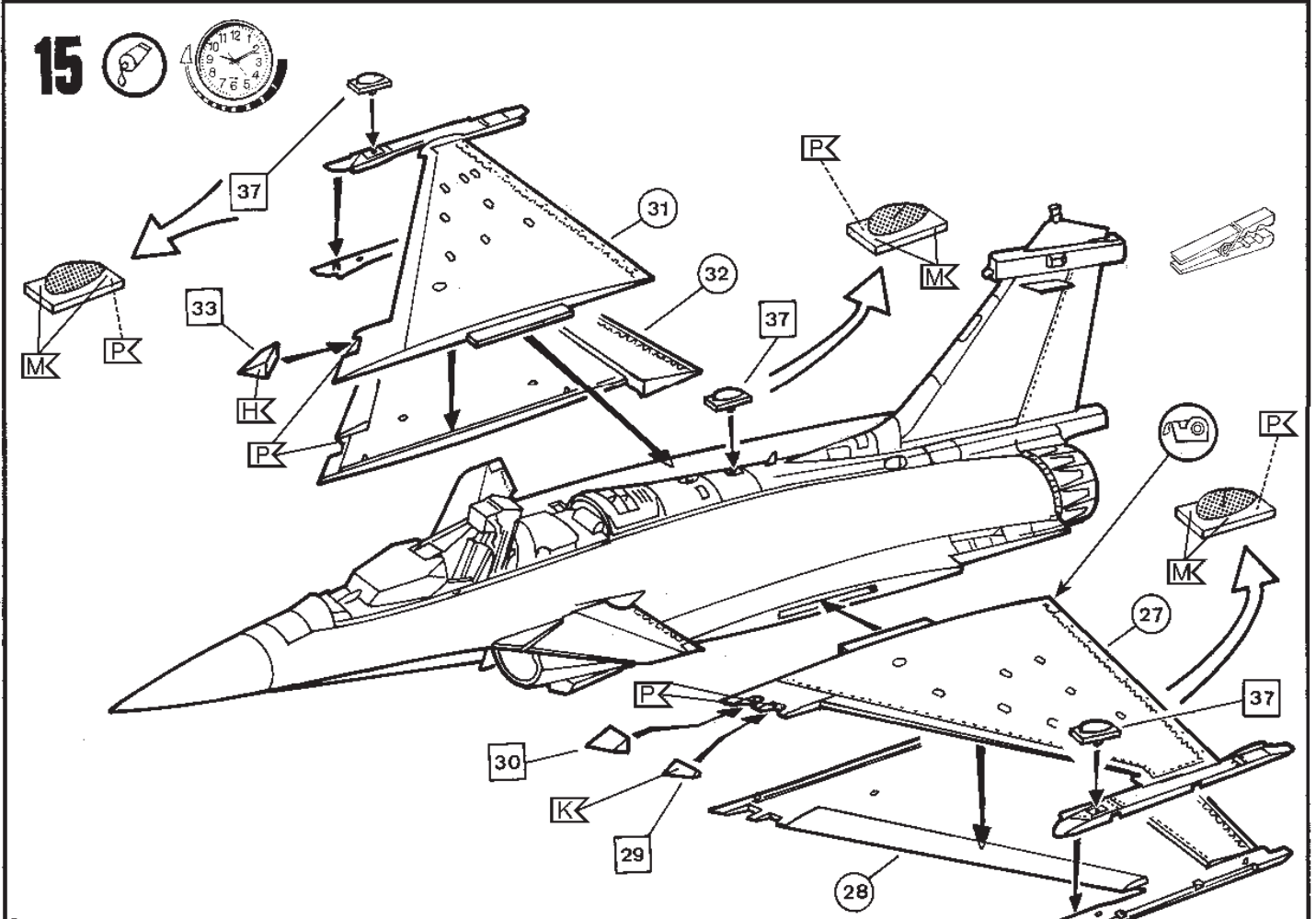
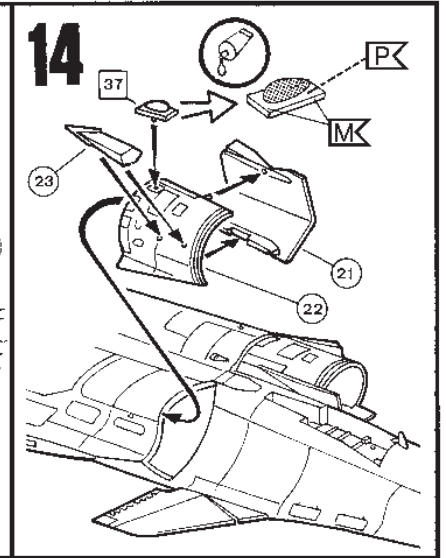
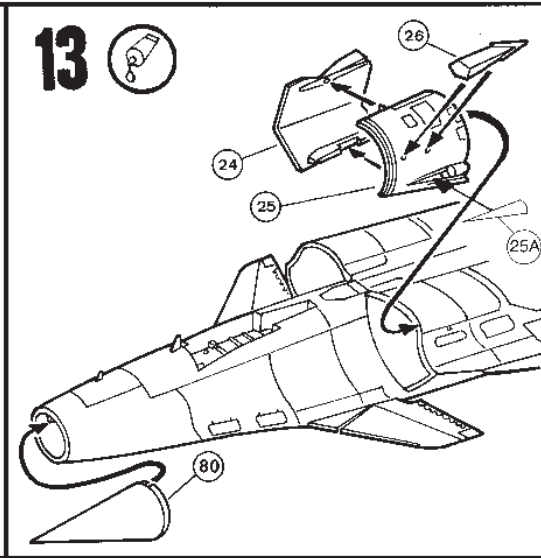
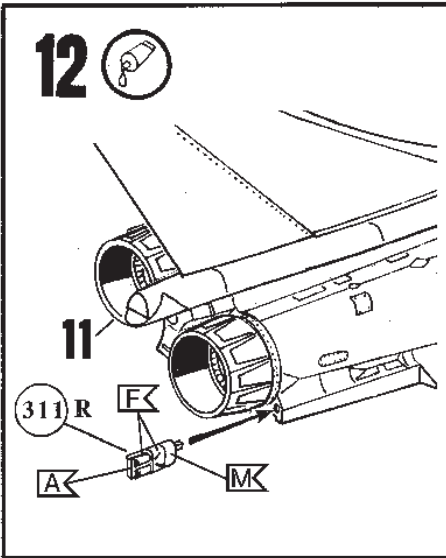

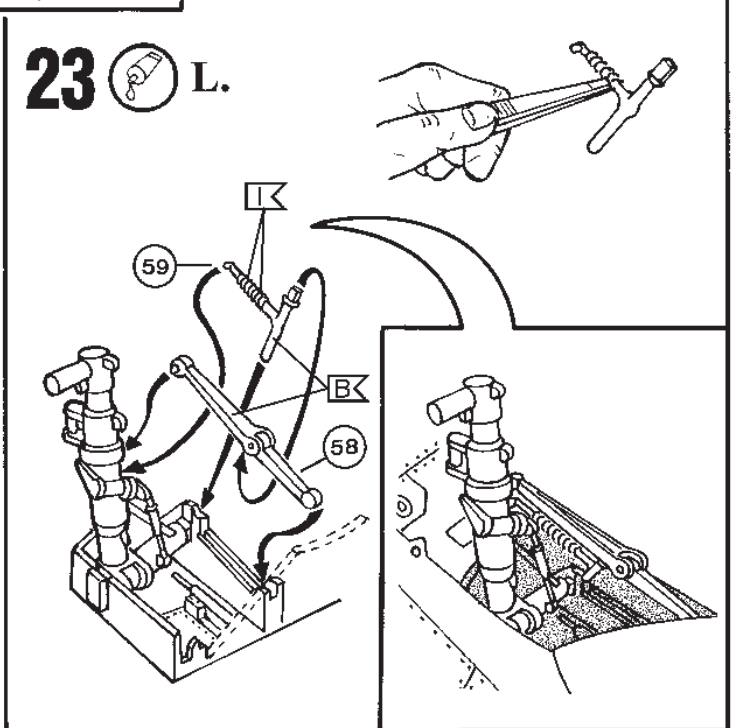
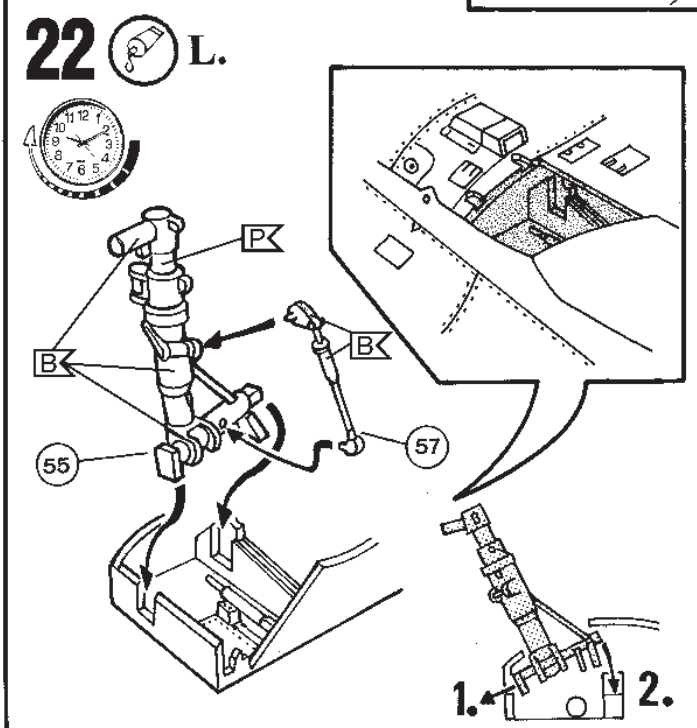
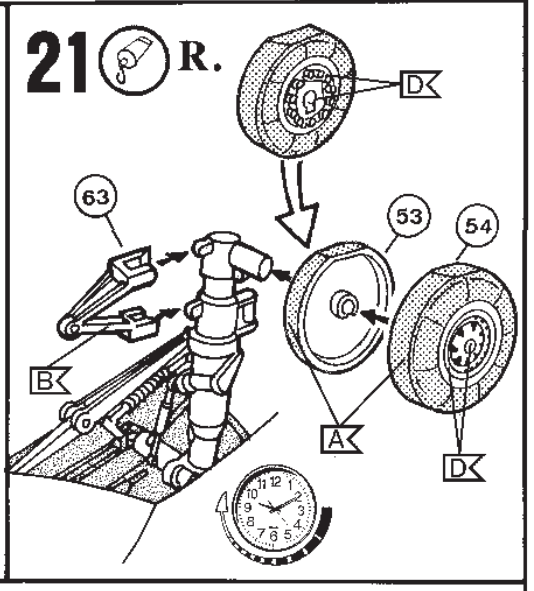
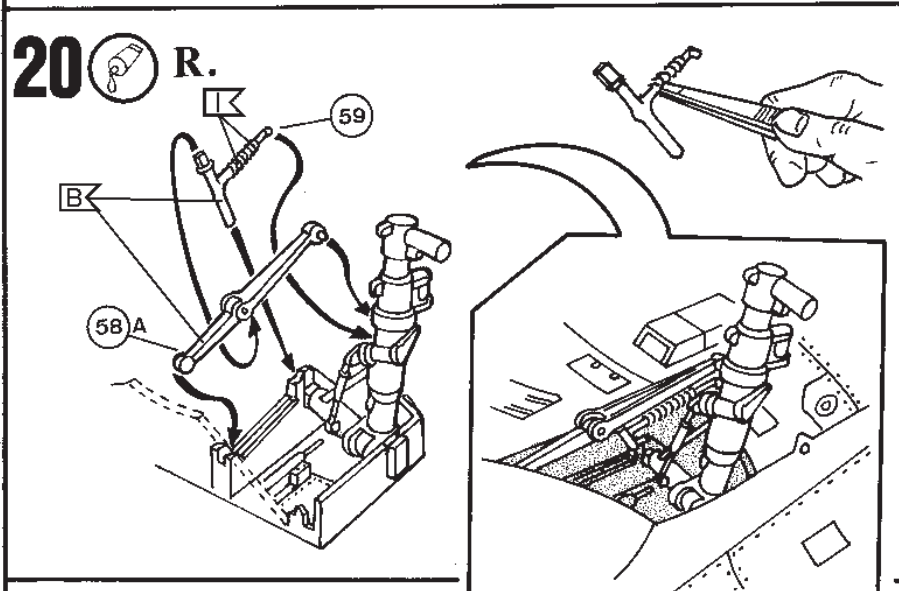
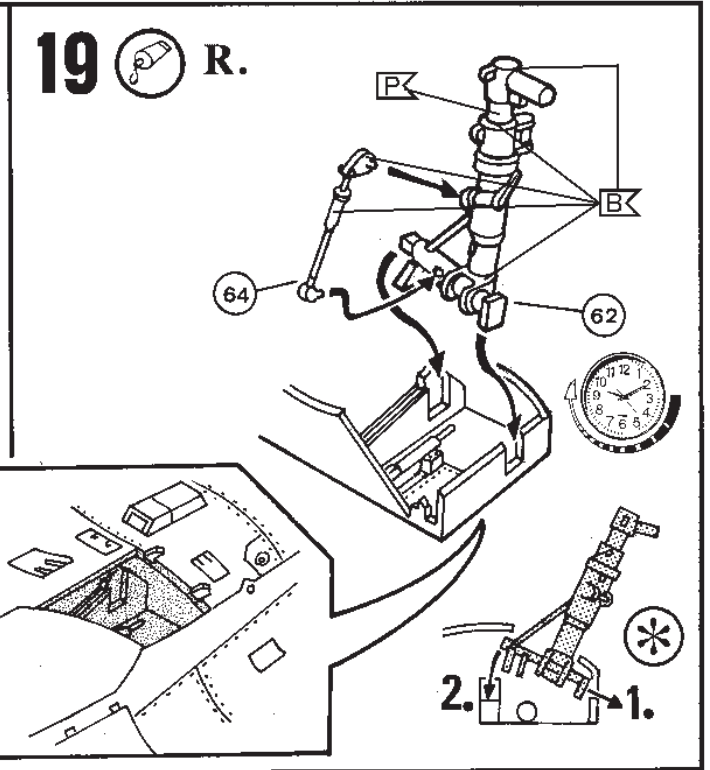
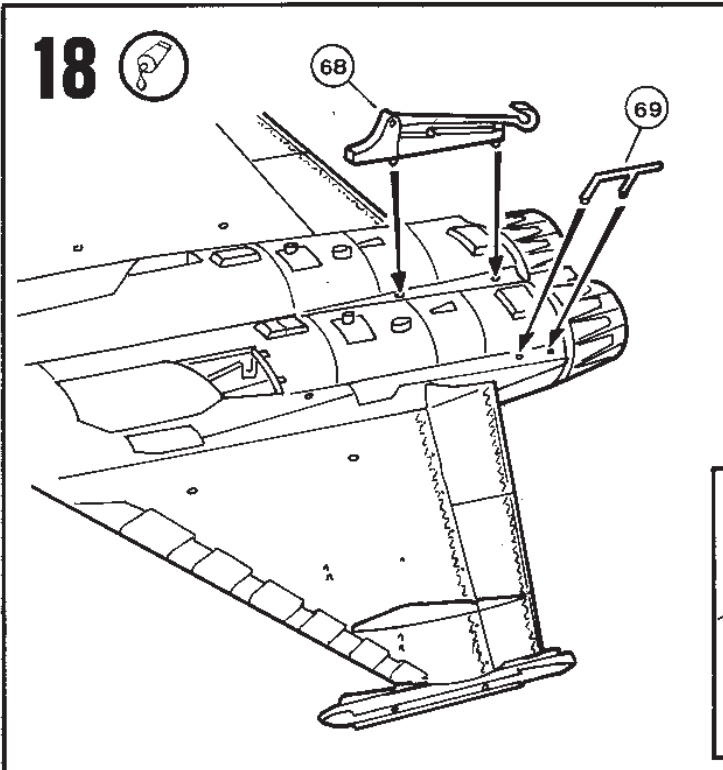

24 L.

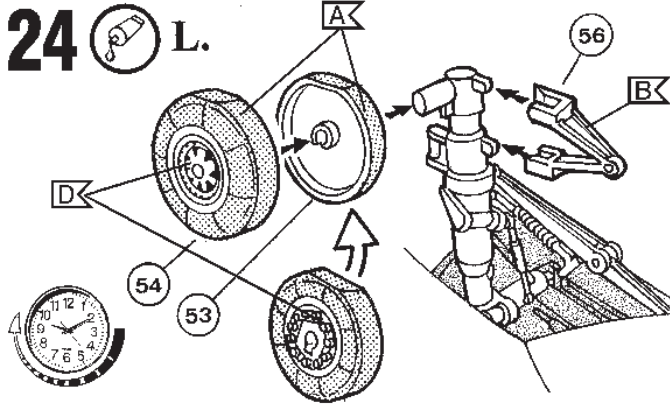

25 L.

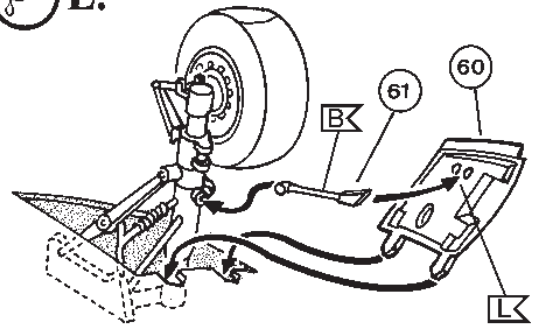

26 R.

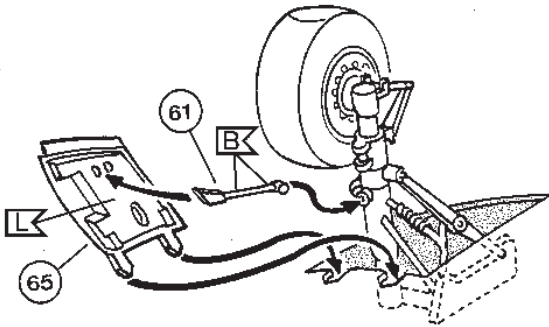

27 ?

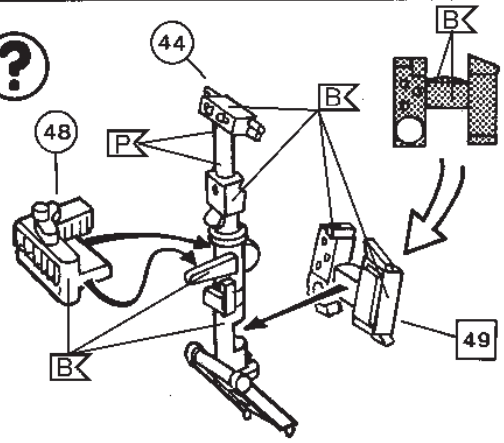

28

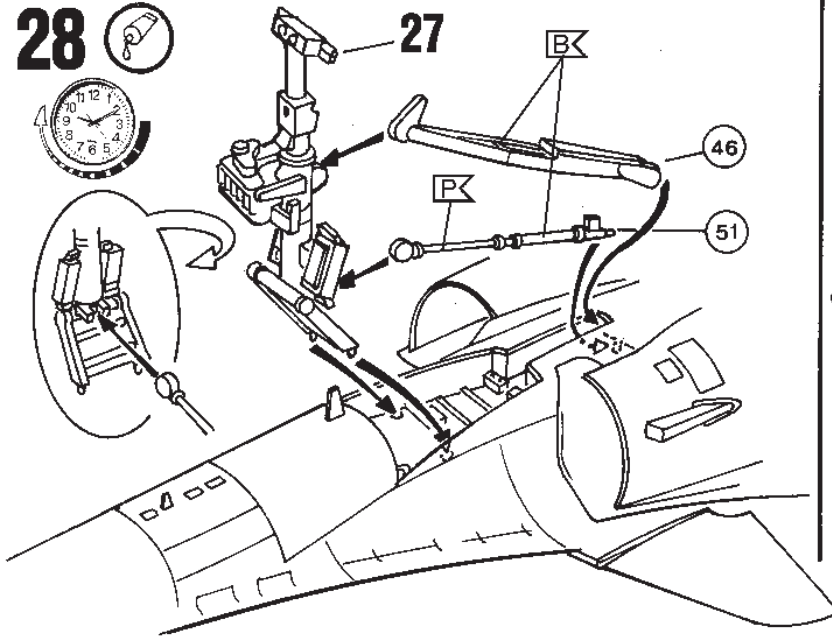

29 ?

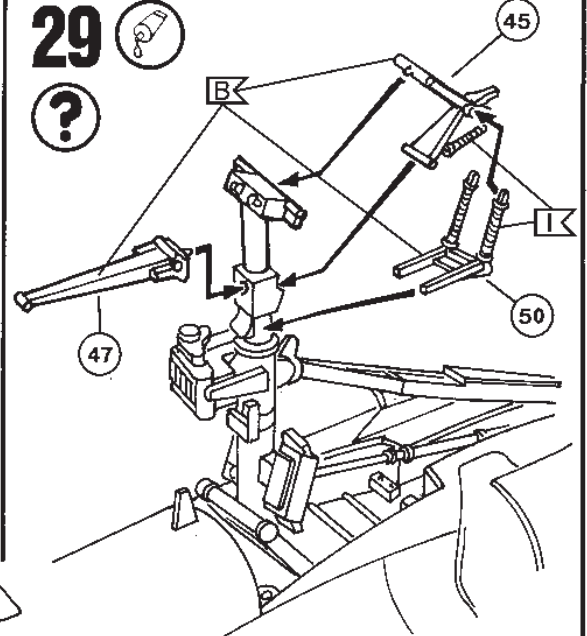

30 ?

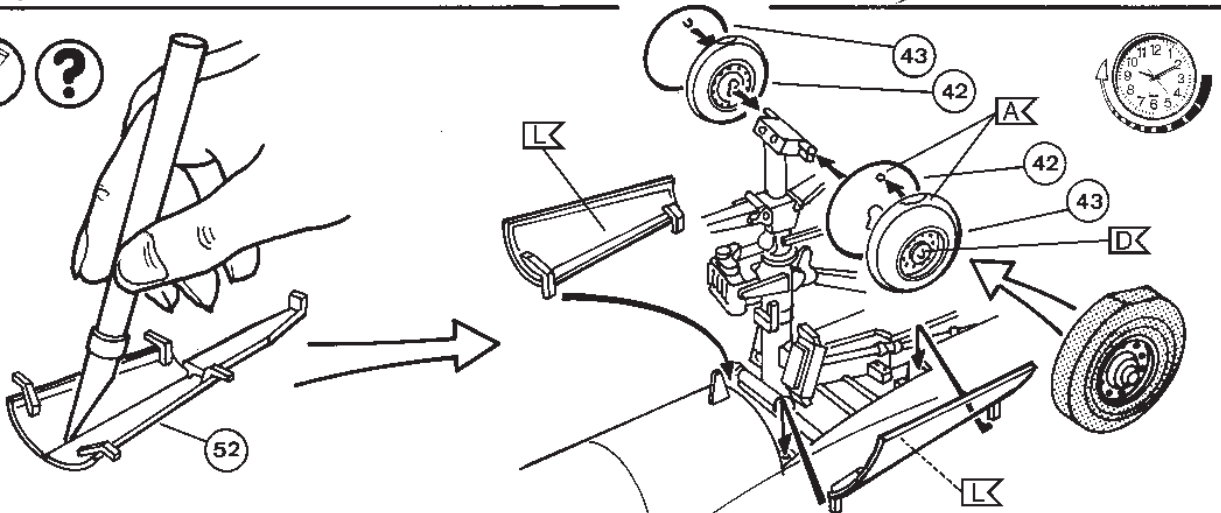

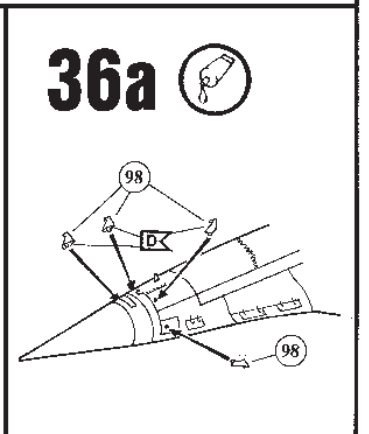
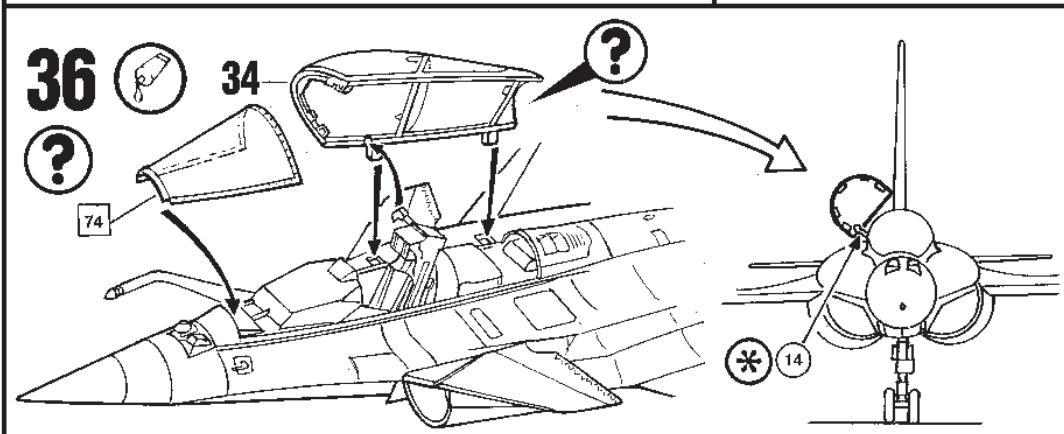
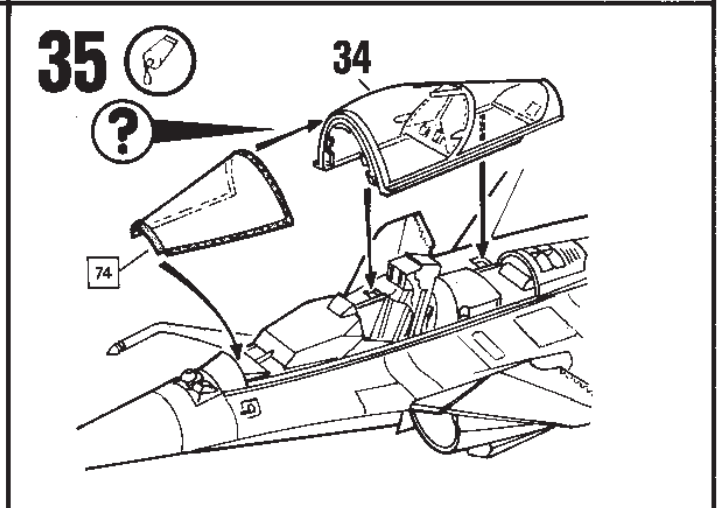
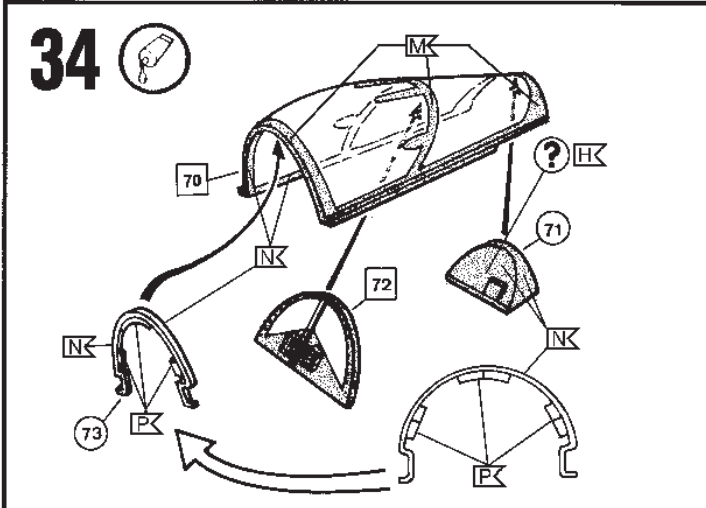
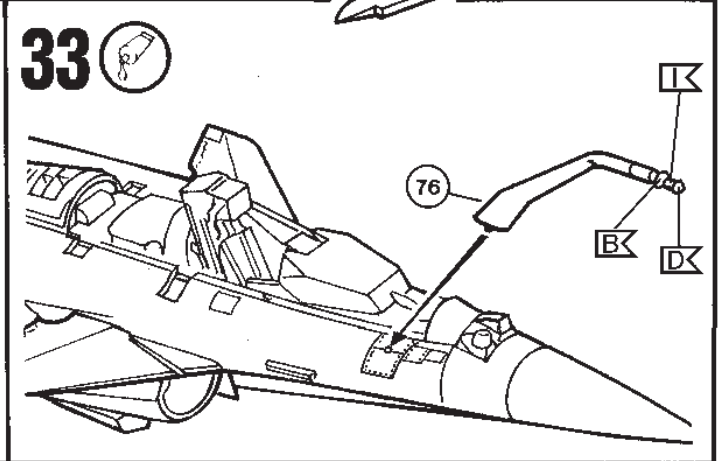
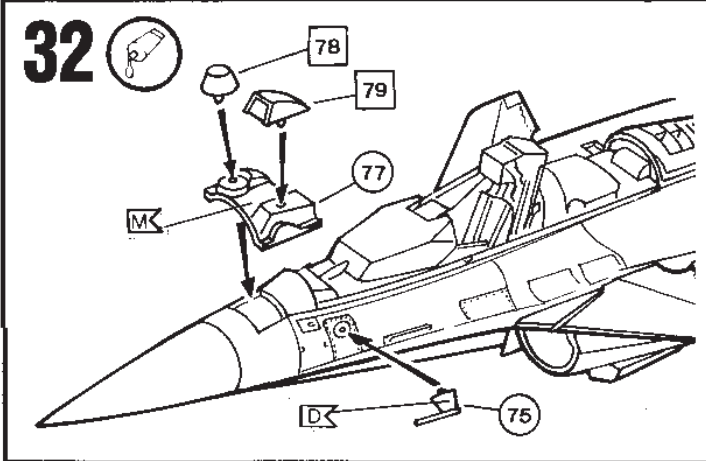
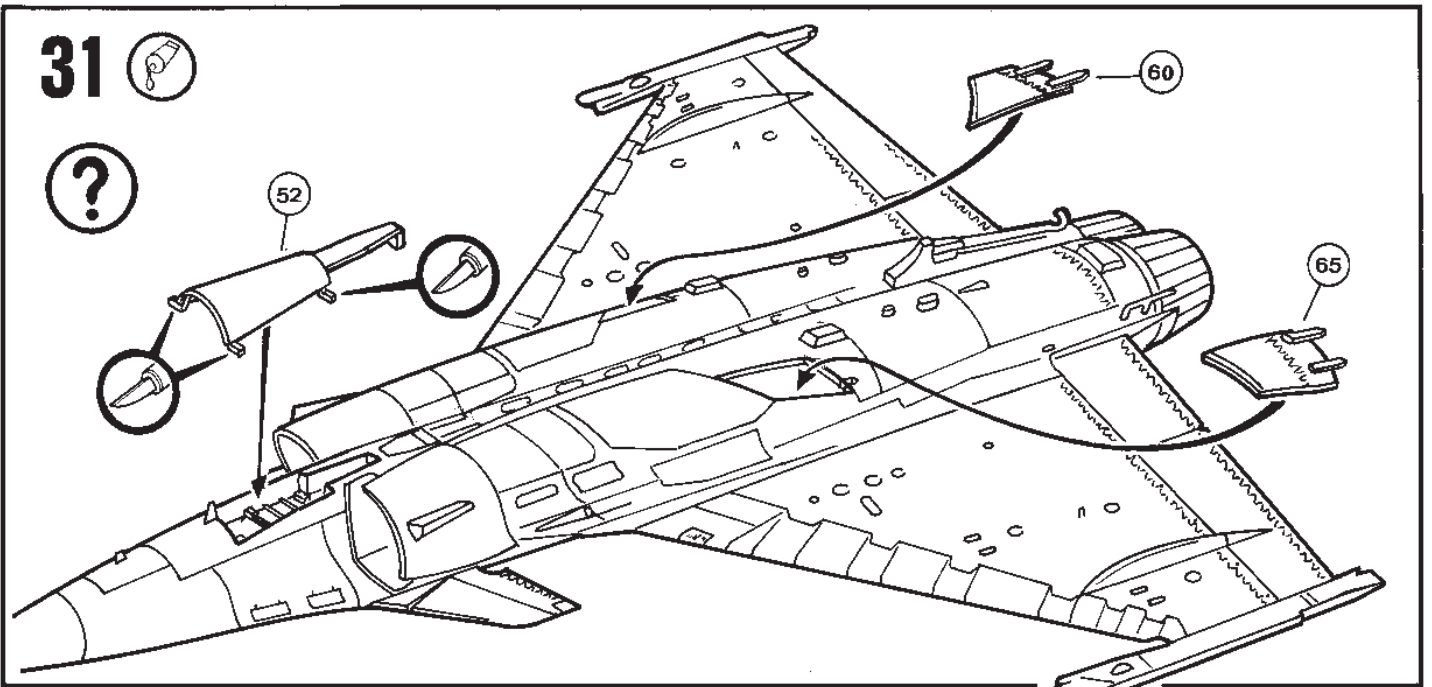

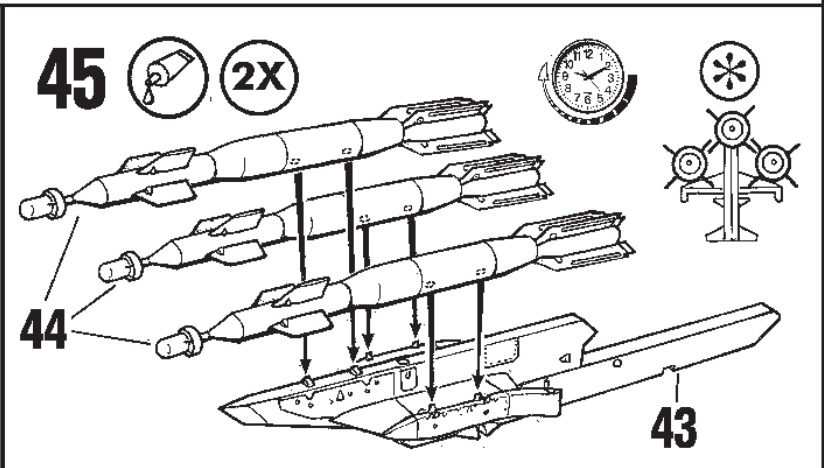
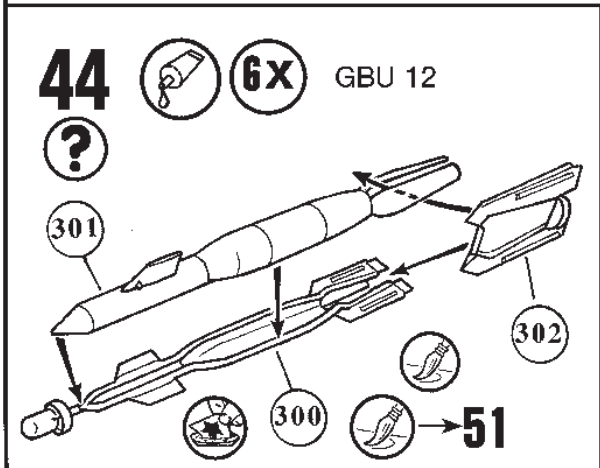
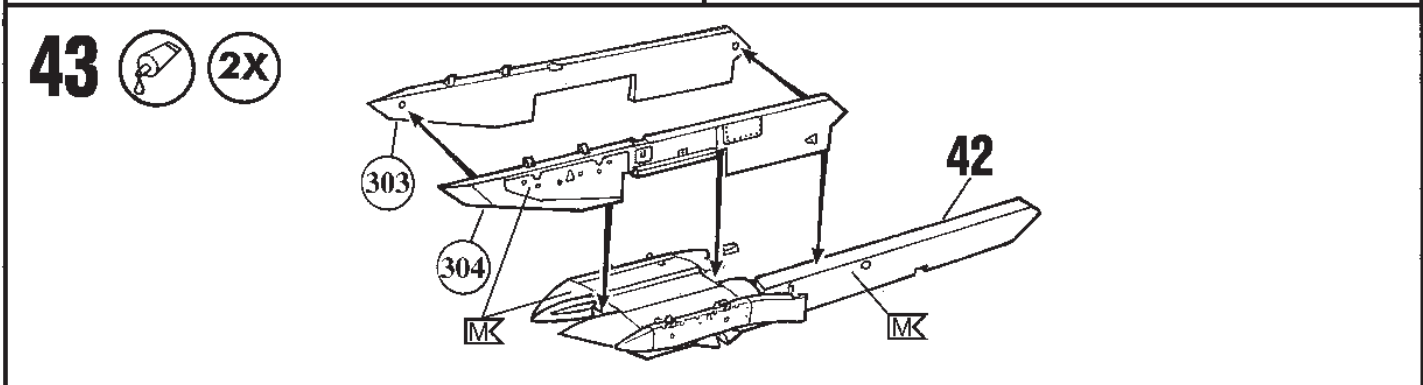
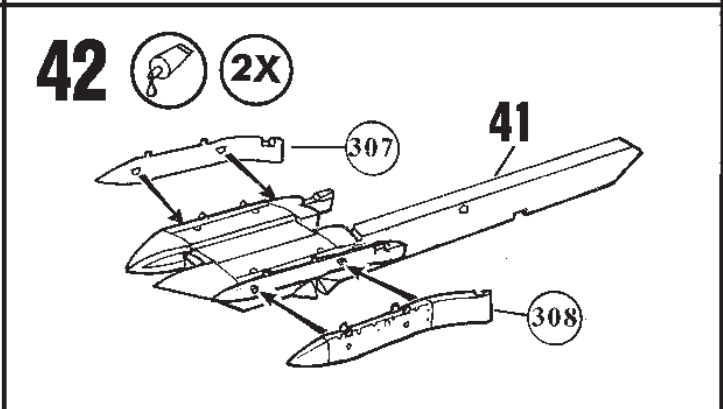
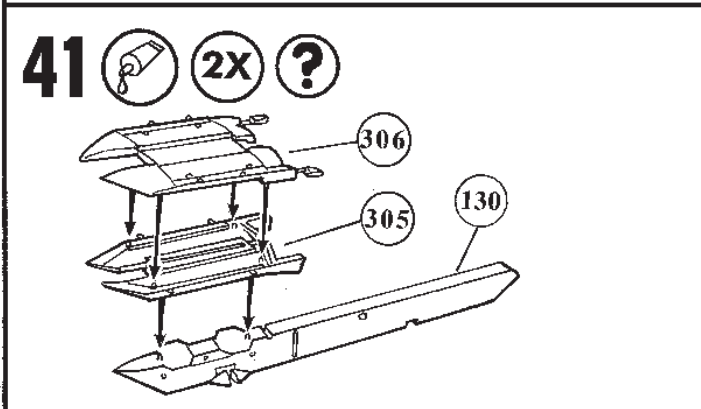
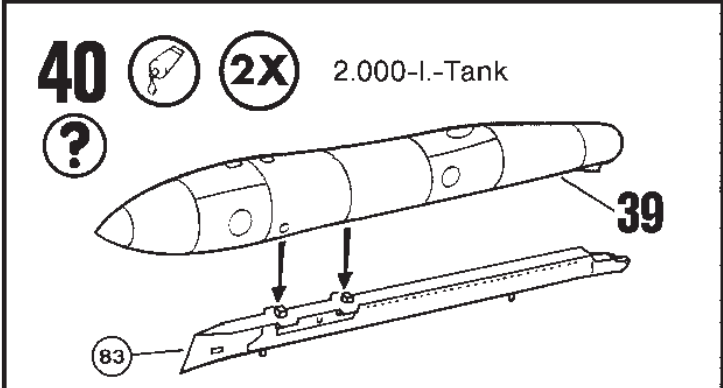
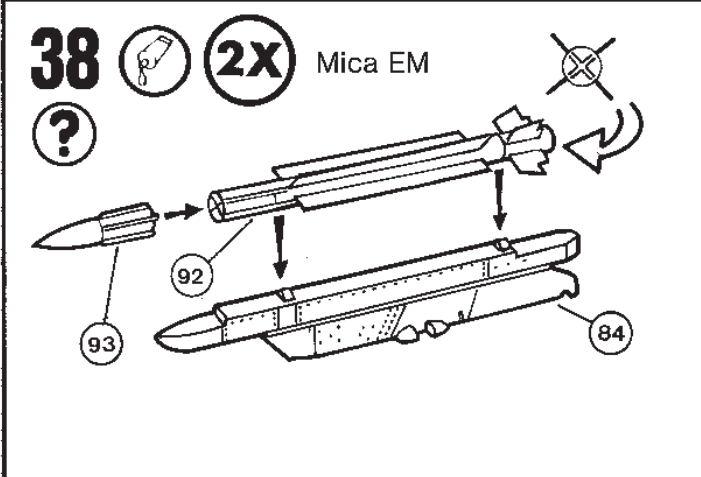
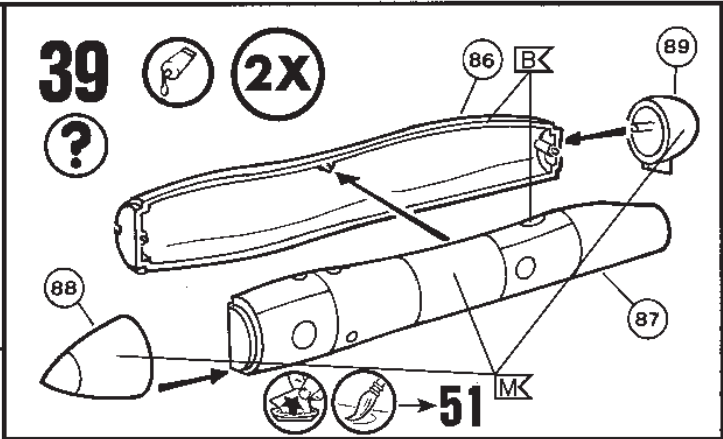
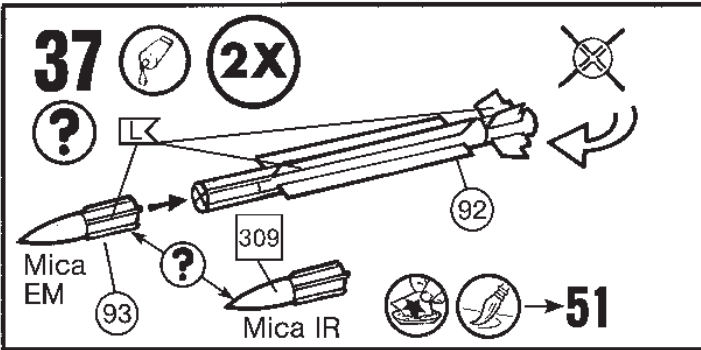

46

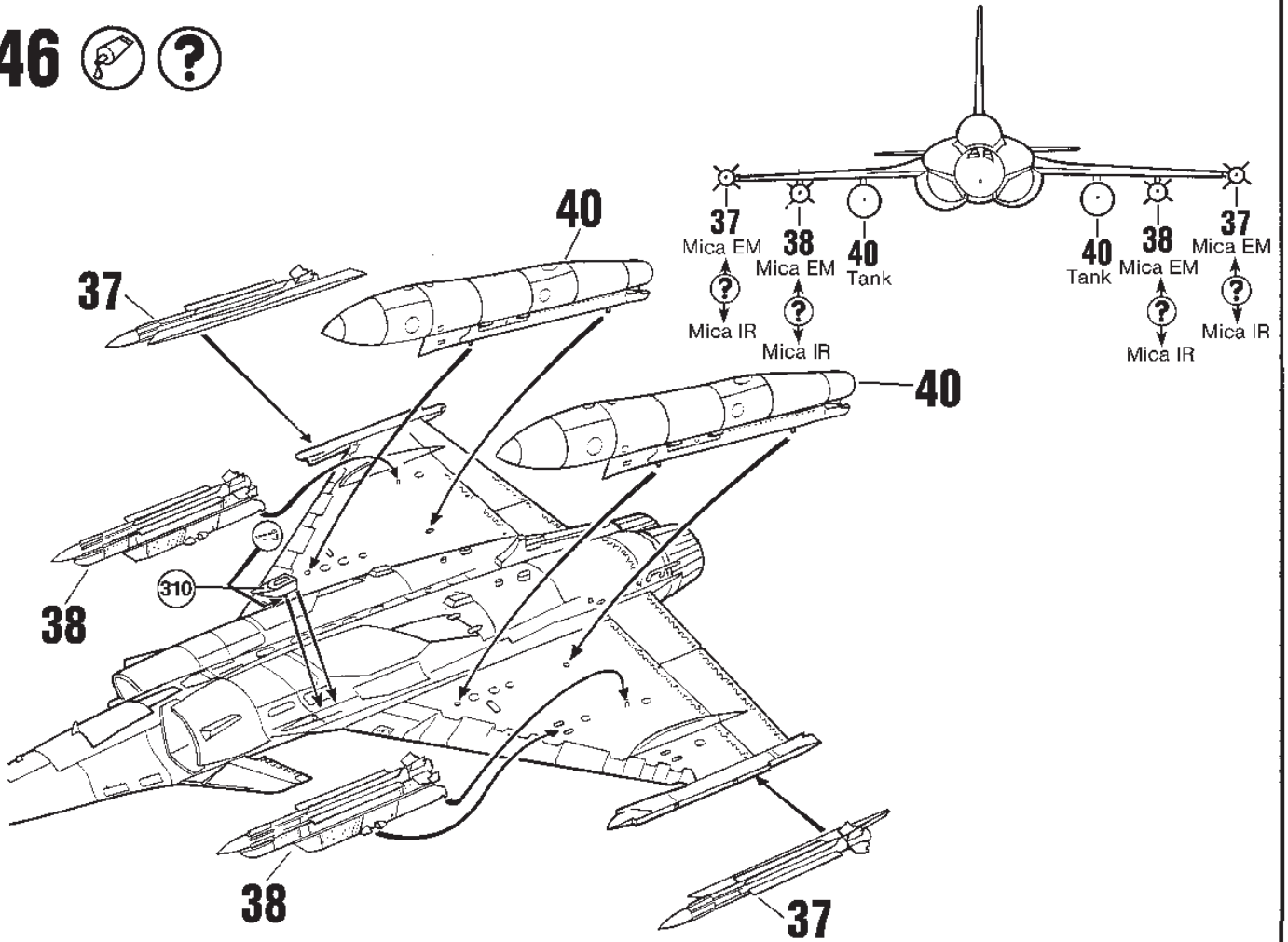

47

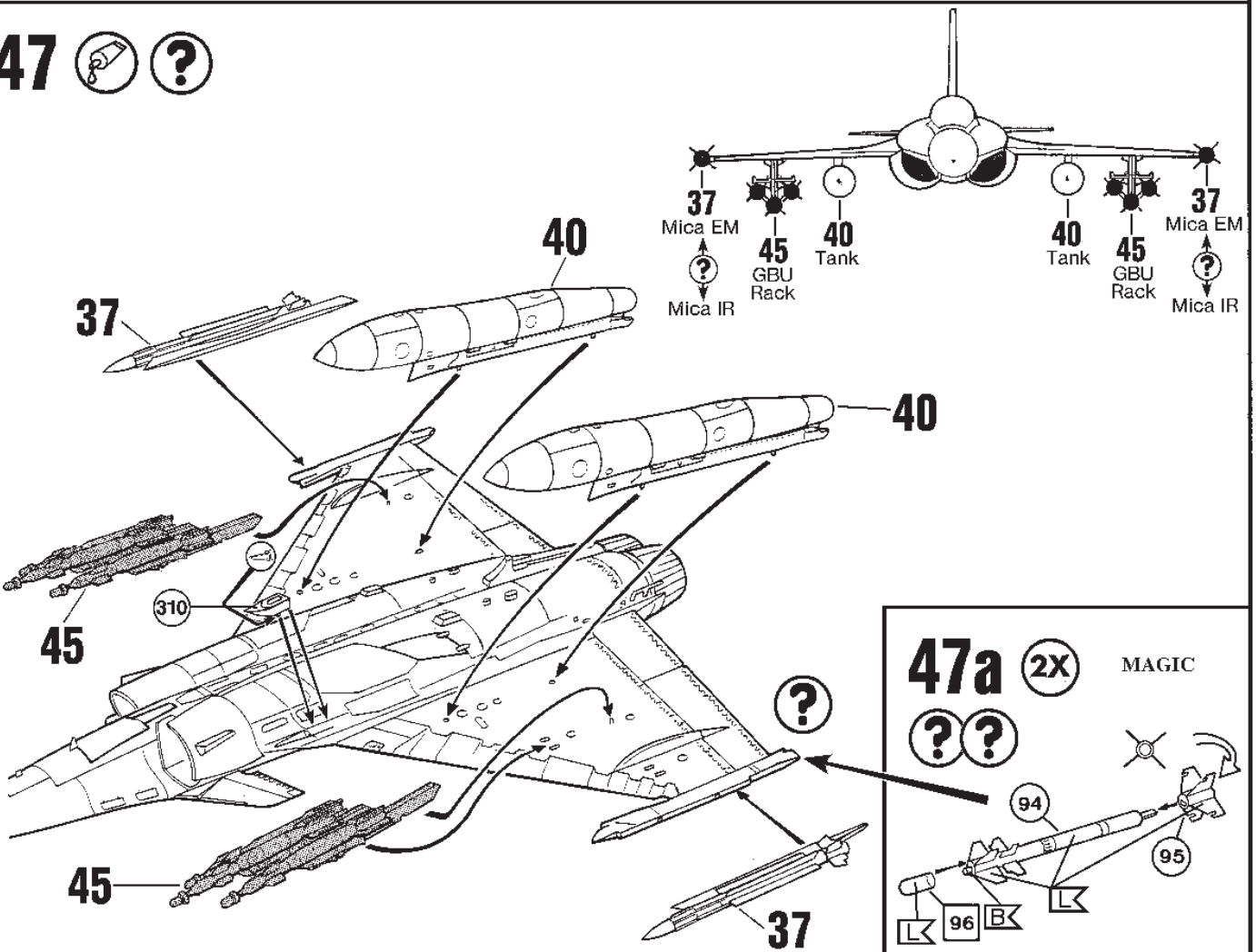

48



Dassault Rafale M - General decals

20 or 21 or 22

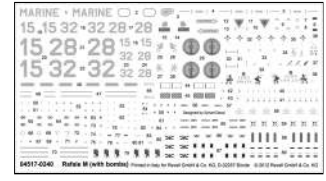
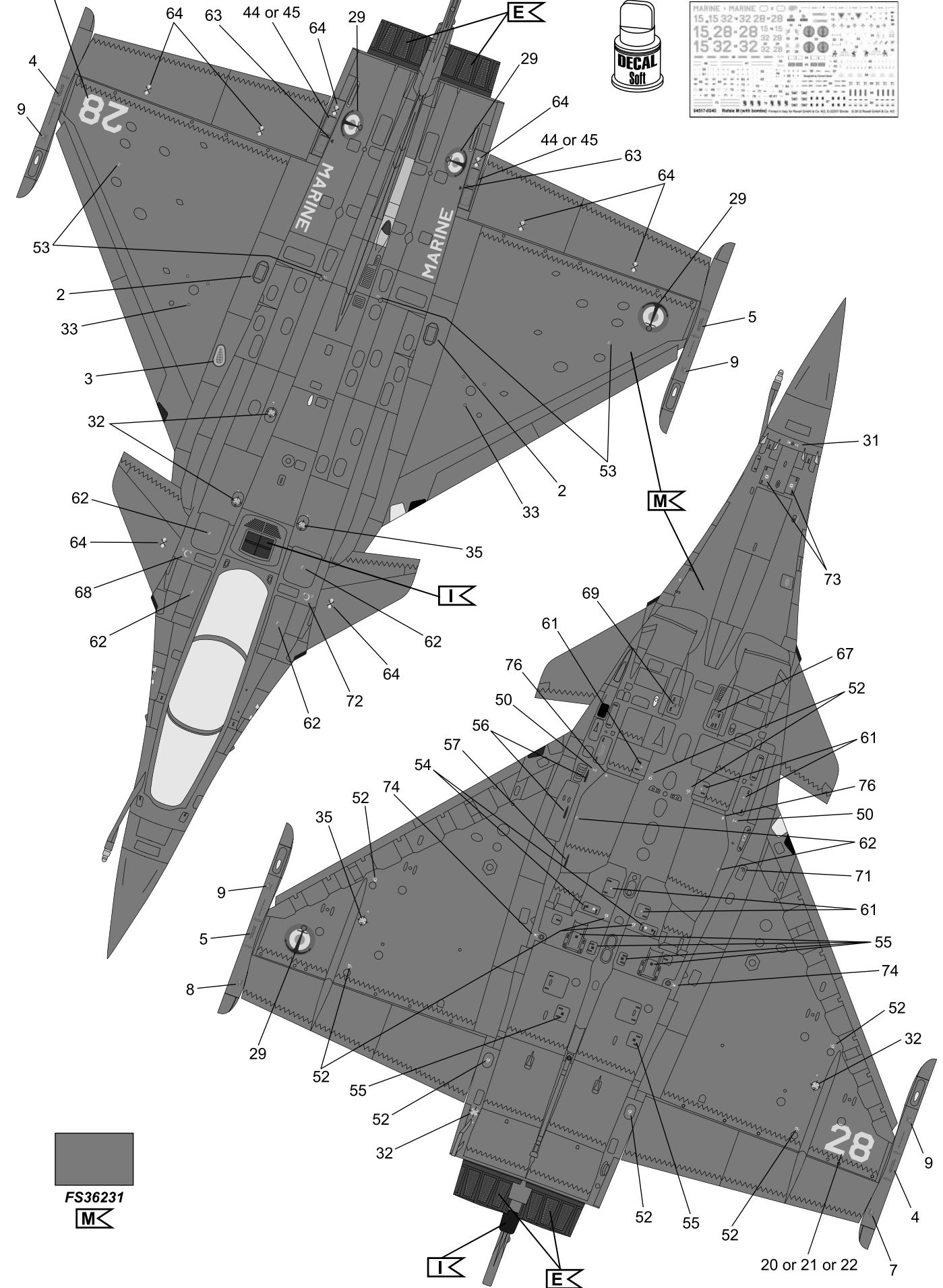

FS36231
I

49



Dassault Rafale M #15 - Operation Harmattan Flottille 12F - R91 Charles de Gaulle - Lybia 2011



50



Dassault Rafale M #32 - First Rafale on Flottille 11F BAN Landivisiau - February 2012



51



Dassault Rafale M - Weapons & fuel tanks

GBU-12 Laser guided bomb

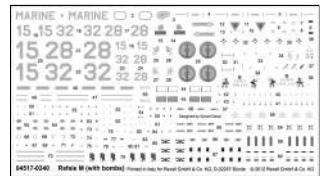

Right view

Left view

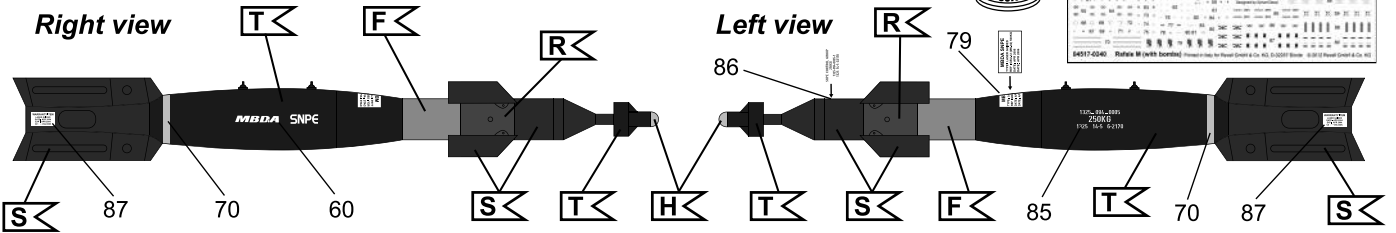

Air to Air Missile MICA EM

Air to Air Missile MICA IR

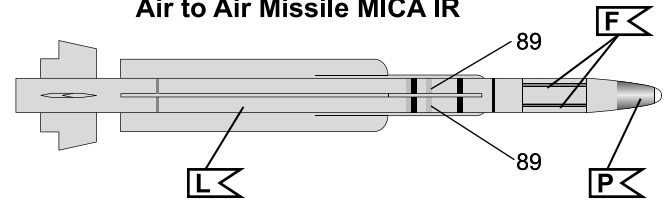
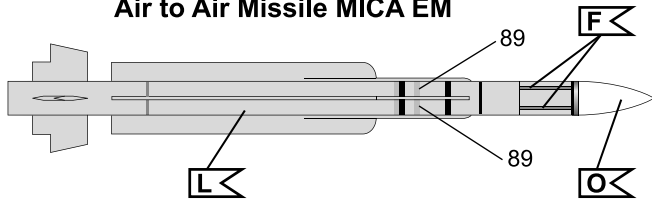

Fuel Tank 2000L

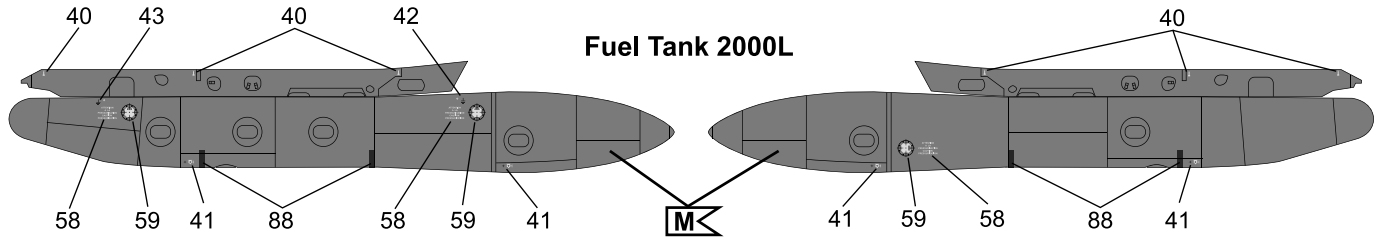

52



Dassault Rafale M #28 - DET CEPA (Tests & Experimentations) 100 Ans Aéronavale - BAN Hyères-Le Palyvestre July 2010

