

VOUGHT F4U-4 CORSAIR

1/48 Scale

Of all the American fighters used in World War II, one of the most distinctive and most feared was the Vought F4U Corsair. Distinctive in both shape and sound, the Japanese called the gull-winged fighter the "Whistling Death" because of the sound made by the wind rushing through the air intakes in the wings. No doubt the rapid staccato of the Corsair's four 20 mm cannon also evoked fear in its enemies as well.

Following the war, development of the Corsair continued and newer models were introduced into service. Among the types operational at the outbreak

of the Korean war was a more powerful version, the F4U-4. A 2,450 hp Pratt & Whitney R-2,800 Double Wasp pushed the big fighter to a speed of more than 450 mph.

During the Korean war, Corsairs were able to carry up to 4,000 lbs of bombs, and the former fighter became a very effective ground-attack plane. The first F4U-1 Corsair flew on May 29, 1940. By December, 1952, the last of 12,571 of the planes was delivered, making the fighter one of the most prolific American planes to defend our skies.

| ENGLISH | FRENCH | GERMAN | SPANISH | ITALIAN |
|----------|----------|----------|----------|-----------|
| WHITE | BLANCO | WEISS | BLANC | BIANCO |
| YELLOW | JAUNE | GELB | AMARILLO | GIALLO |
| RED | ROUGE | ROT | ROJO | ROSSO |
| BLUE | BLEU | BLAU | AZUL | BLU |
| GRAY | GRIS | GRAU | GRIS | GRIGIO |
| GUNMETAL | METALLIC | METALLIC | METALICO | METALLICO |
| GREEN | VERT | GRUN | VERDE | VERDE |
| SILVER | ARGENT | SILBERN | PLATA | ARGENTO |
| BLACK | NOIR | SCHWARTZ | NEGRO | NERO |

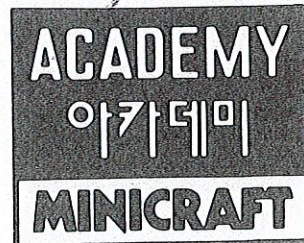

Cement Parts
Coller
Kleben
Pegar
Incollare



DO NOT cement
Ne pas coller
Nicht Kleben
No pegar
Non incollare



Cut away
Couper
Scheiden
Cortar
Tagliare
Cortar



Optional parts
Choix
Auswahlmöglichkeit
Elección
Scelta
Oncao



3

Repeat operation
Répéter l'opération
Vorgang wiederholen
Repitir la operacion
Ripetere
Repitir a operação

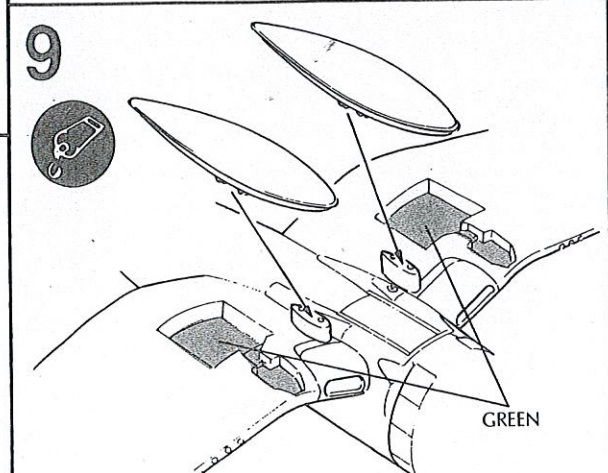
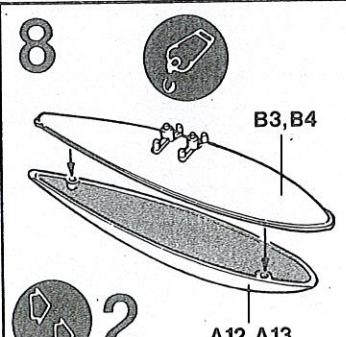
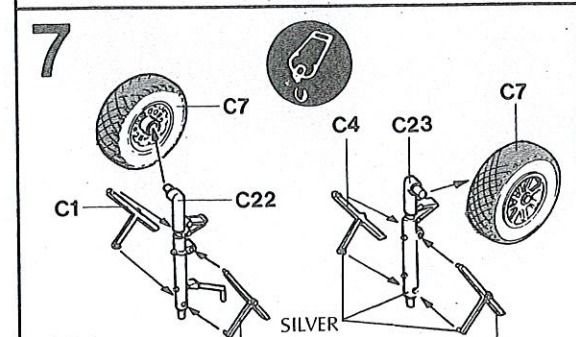
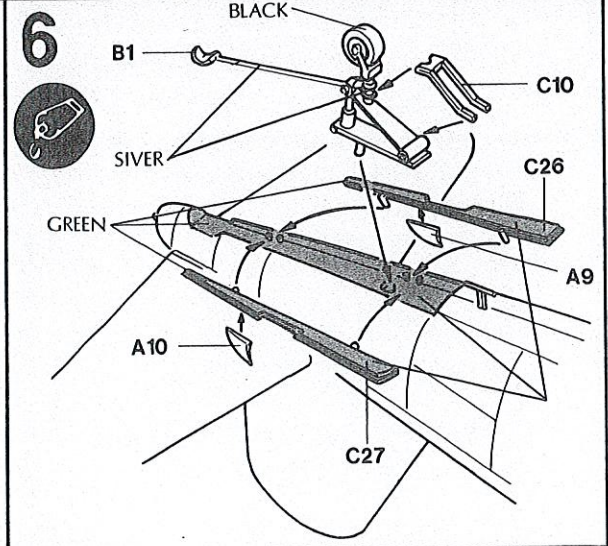
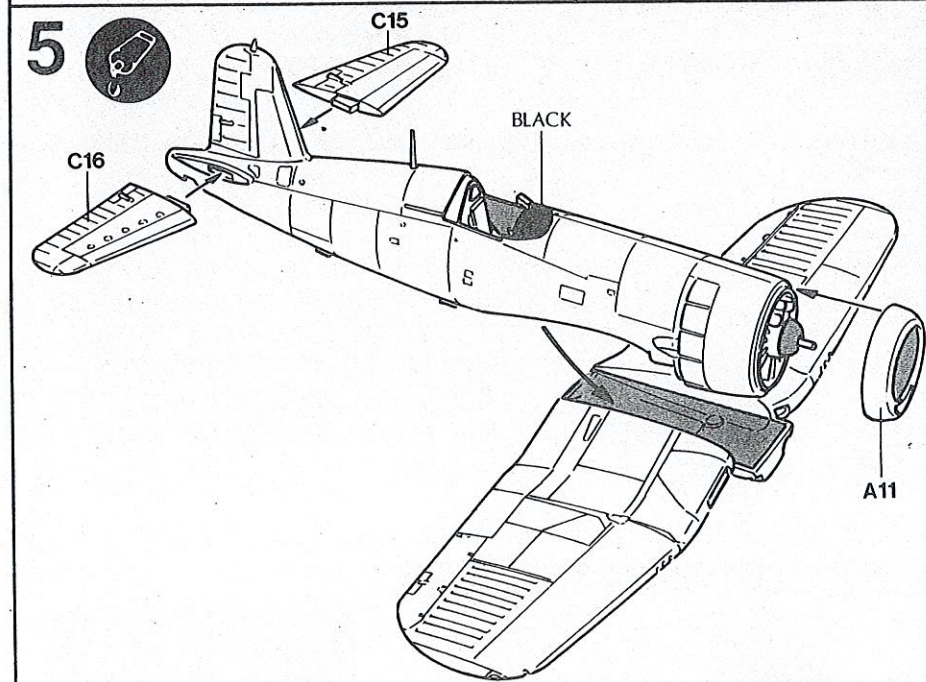
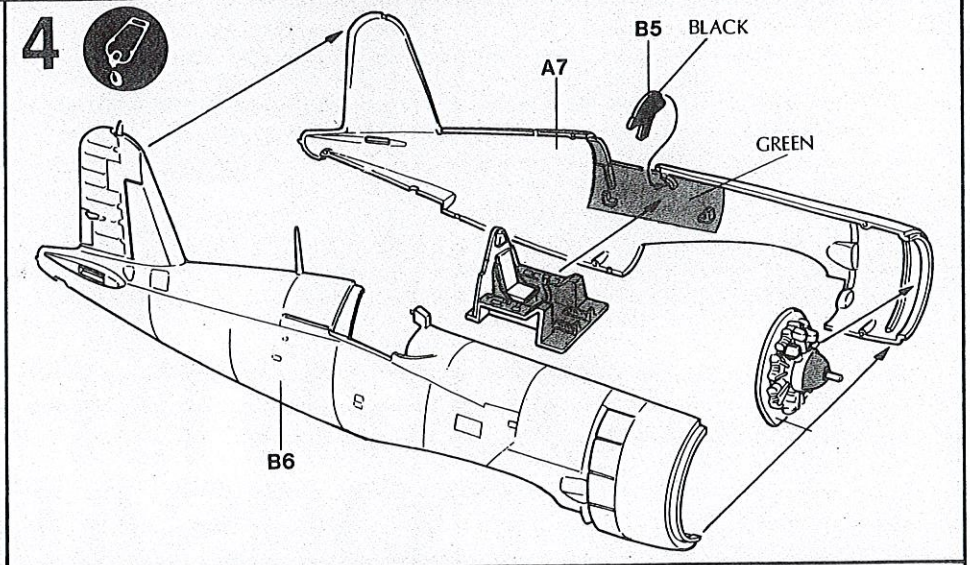
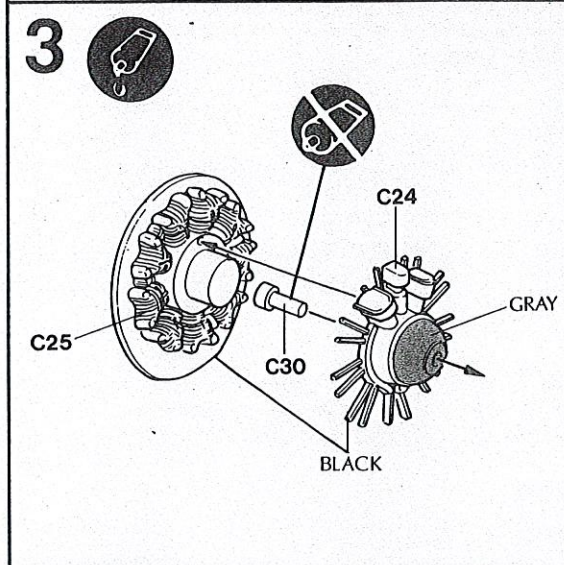
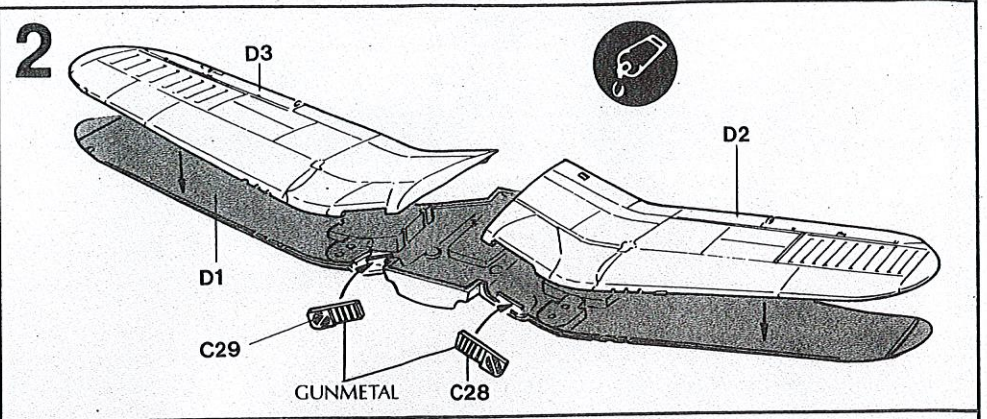
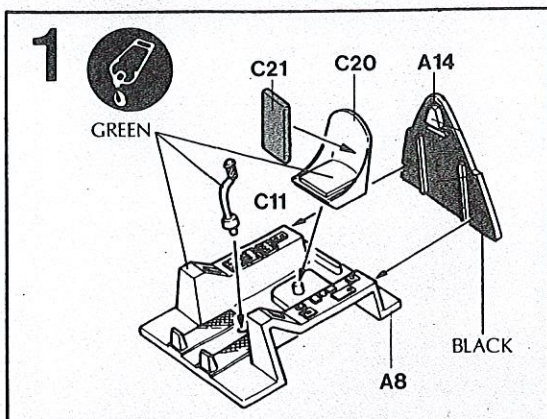

10

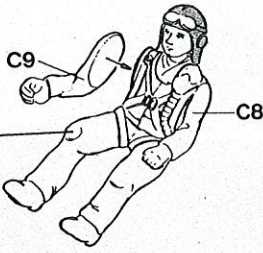

11

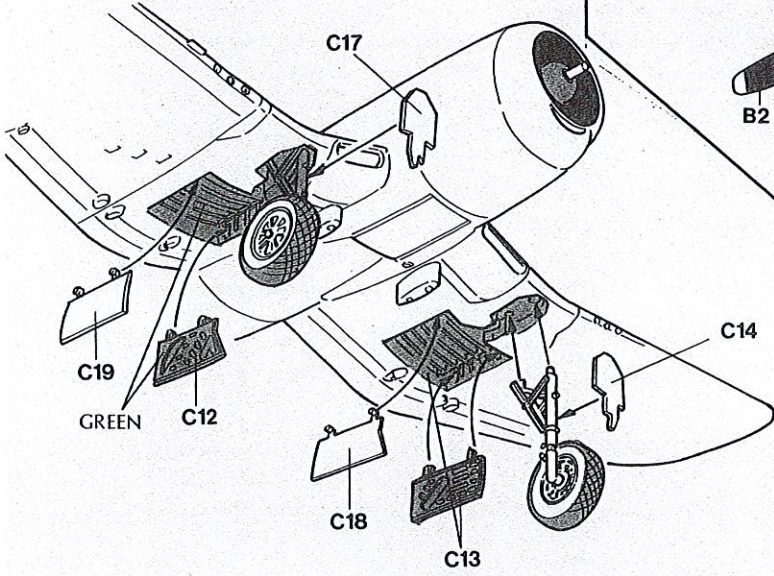
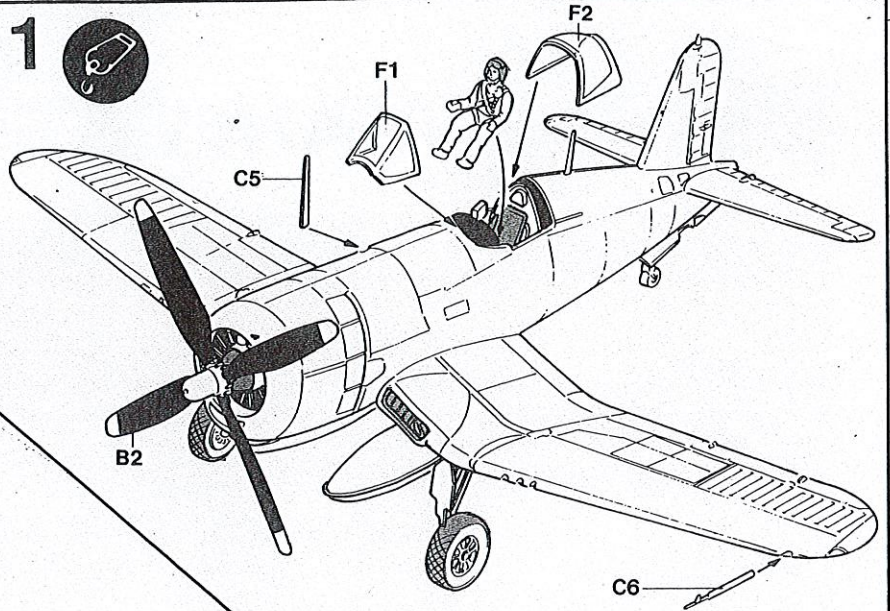

OVERALL GLOSSY SEA BLUE-FS 15042

Refer to box top for additional paint and decal information.

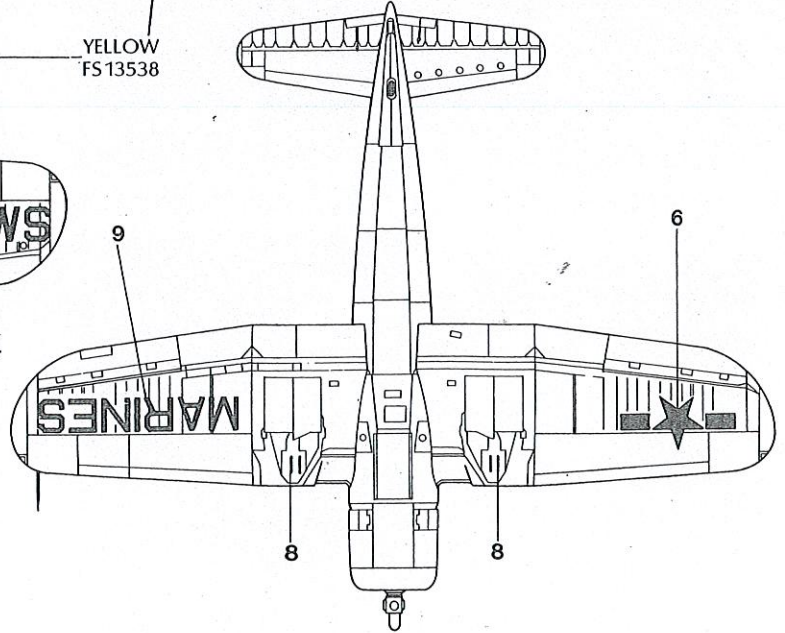
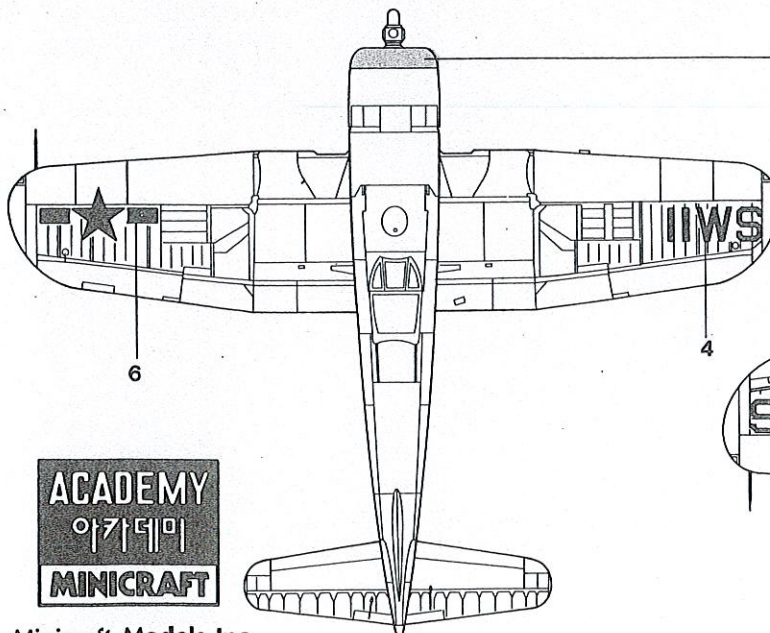
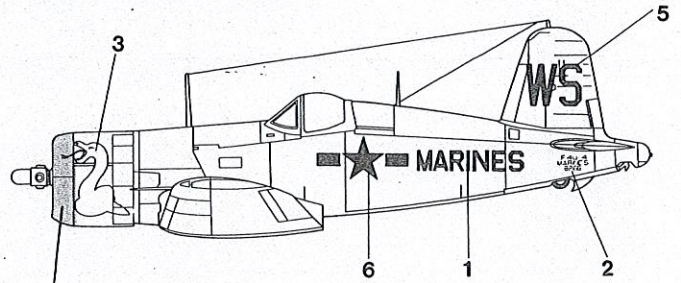
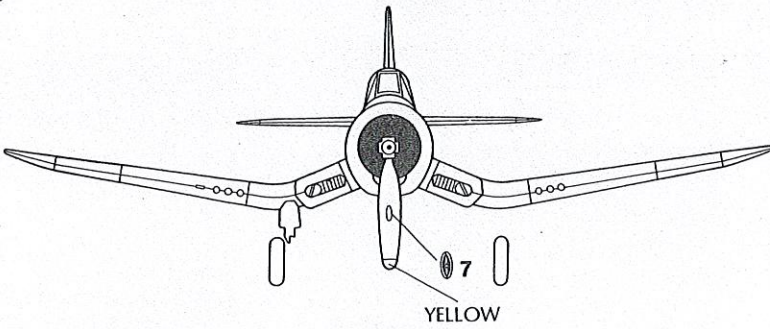

ACADEMY
아카데미
MINICRAFT

Minicraft Models, Inc.
1510W.228th St.
Torrance, Calif 90501

Copyright 1988 Minicraft Models Inc

1656



1/48 F-5A NORTHROP FREEDOM FIGHTER 1631

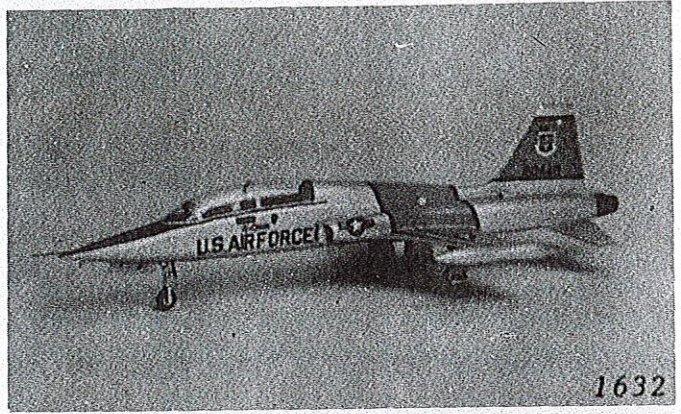

1/48 NORTHROP F-5B FREEDOM FIGHTER 1632

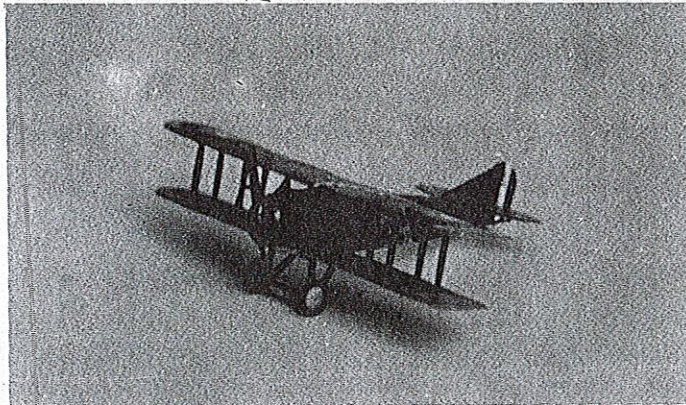

1/72 SPAD XIII WW I FIGHTER 1623

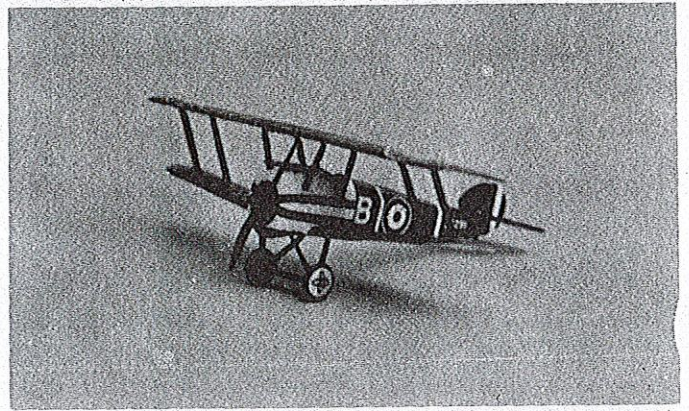

1/72 SOPWITH CAMEL WW I FIGHTER 1624



1/72 F-5A NORTHROP FREEDOM FIGHTER 1633

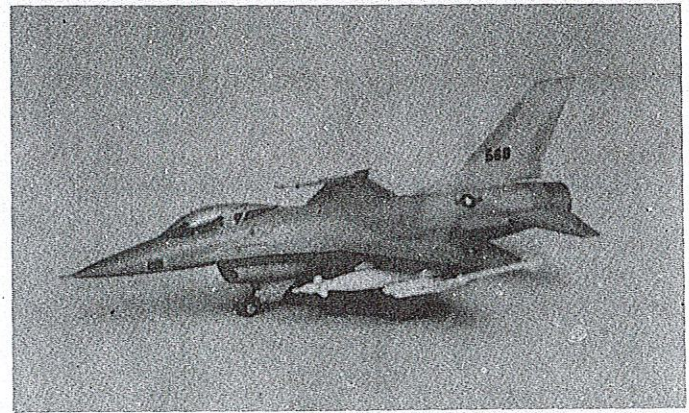

1/72 YF-16 FIGHTING FALCON 1620

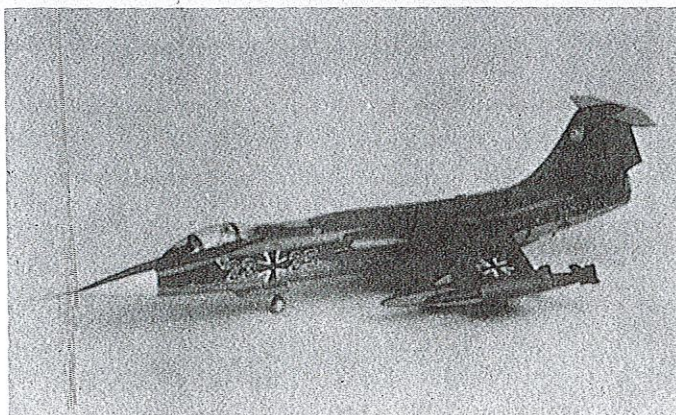

1/72 LOCKHEED F-104C STARFIGHTER 1610

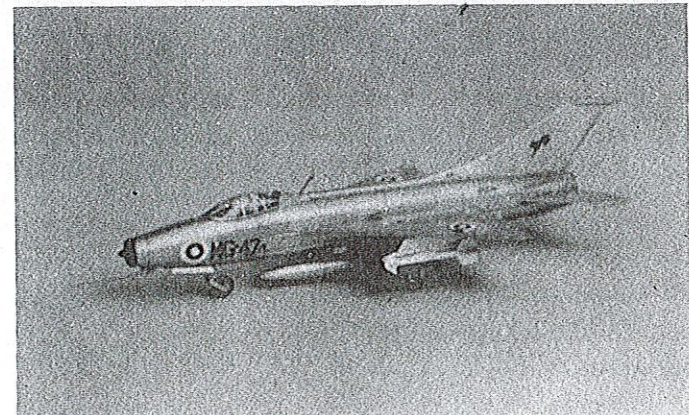

1/72 MIG-21 FISHBED 1618