

# ACADEMY

HOBBY MODEL KITS

## 12426

# F-14A TOMCAT

## "VF-84 Jolly Rogers 1980"



1/72nd Scale

F-14A 톰캣  
"VF-84 롤리 로저스 1980"

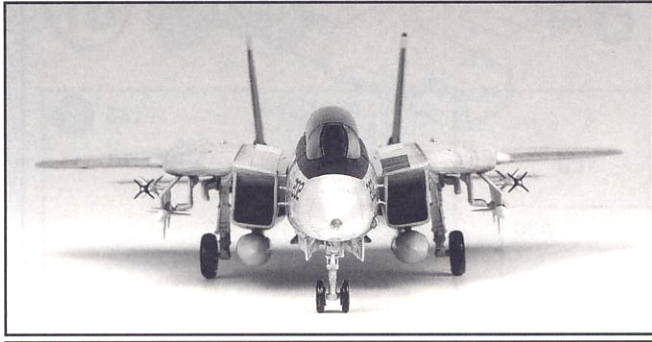

No.	Color Name	GSI CREOS		LIFE COLOR	HUMBROL	TESTOR/MODEL MASTER		Notes
		HOBBY COLOR	Mr. COLOR			ENAMEL	ACRYL	
1	FLAT BLACK	H<12>	33	LC02	33	1749	4768	무광검정색
2	KHAKI	H<81>	55	UA039	72	1792		카키색
3	YELLOW	FS13538	329	UA140	154	1708	4721	노랑색
4	DARK GULL GRAY	FS36231	H<317>	UA033	140		4755	다크 걸그레이
5	WHITE	FS17875	H<316>					항광백색
6	SILVER		H<8>	LC74	11	1790	4678	은색

7	BURNT IRON	H<76>	61	LC74(80%) + LC02(40%)	56	1796	4676	흑철색
8	GULL GRAY	FS16440	H<315>	UA25	129		4692	걸그레이
9	CLEAR BLUE	H<93>	50				4658	클리어 블루
10	CLEAR RED	H<90>	47		1321		4630	클리어 레드
11	METALLIC GRAY	H<28>	61	LC76	12533	1795	4681	메탈릭 그레이
12	RADOM	H<318>	318		148	1709	4722	레이돔

<p>접착한다. Cement parts Glue Kleben Pegar Incollare Colar Kleven</p>	<p>접착하지 않는다. Do not cement Ne pas coller Nicht kleben No pegar Non incollare Nao colar Niet kleven</p>	<p>3 수반을 조립한다. Repeat operation Répéter l'opération Vorgang wiederholen Ripetir la operacion Ripetere Repitir a operacion Herhalen</p>	<p>전사지를 붙인다. Decals Décalcomanies Abziehbild</p>	<p>9 무게추를 붙인다. Add weight Leiter Gewicht</p>	<p>구멍이나 홈을 채워준다. Use filler Masticquer Schließen</p>
<p>잘라낸다. Cut away Couper Schneiden Cortar Tagliare Cortar Snijden</p>	<p>선택한다. Optional parts Choix Auswahlmöglichkeit Eleccion Scelta Opcao Keuze</p>	<p>반대쪽도 조립한다. Repeat for opposite side Répétition de la page Wiederholung für gegenüberliegende Seite</p>	<p>구멍을 뚫어준다. Make hole Faire un trou Öffnen</p>	<p>주의한다. Be careful Faire attention Hier Vorsicht</p>	<p>색칠 및 전사지 붙이기 번호 Painting scheme number Numeros de la lista de pinturas Lackierschemanummer</p>

### ⚠️ 보호자 분들은 반드시 읽어 주십시오.

- 조립하기 전에 취급 설명서를 꼼꼼히 읽어 내용을 충분히 이해한 상태에서 조립하여 주십시오.
- 부품을 자를 때는 해당번호를 확인한 뒤 니퍼 등으로 깨끗이 잘라 주십시오. 칼을 이용하여 부품을 다듬고 자를 경우 손을 다치지 않도록 세심한 주의를 기울여 주십시오.
- 작은 부품 따위를 절대로 입에 넣지 마십시오. 잘못하여 삼킬 경우 질식 등의 위험이 있습니다. ● 자칫 먹을 우려가 있으므로 3세 미만의 어린이에게는 절대로 주지 마십시오.
- 잘라낸 부품은 깨끗이 다듬어 조립하고 남은 쓰레기는 분리하여 잘 버려 주십시오. ● 기능상 부득이하게 튀어나온 부분이 있을 수 있습니다. 취급 시 충분한 주의를 기울여 주십시오.
- 제품 및 부품이 포장된 비닐봉지는 개봉 후 즉시 어린이의 손에 닿지 않는 곳에 잘 버려 주십시오. 머리에 뒤집어쓰거나 얼굴을 덮을 경우 질식의 위험이 있습니다.
- 색칠 및 접착을 위하여 모형용 도료 및 접착제 등을 사용할 때에는 창문을 열어 환기를 시키고 화기를 멀리하여 주십시오. 사용하고 남은 도료 및 접착제는 어린이의 손이 닿지 않는 곳에 잘 보관하여 주십시오.

- Before starting to assemble, read the instruction manual very carefully to understand well everything of the instructions.
- Before cutting a part off sprue, check the part number again and use proper tool such as nipper to cut it clearly. Take care not to be hurt in use of modelling knife to cut or trim parts.
- Never put small parts in the mouth to avoid any danger of suffocation by accidentally swallowed ones. ● Never let children less than 3 years old have it to avoid any danger of taking it.
- The product may have some protruding parts for functional reasons and take care of handling it always.
- After cutting a part off sprue, trim it clearly to assemble and the wastes should be properly sorted to dispose.
- Plastic bags packed with the product and parts should be disposed in a proper place immediately to keep out of children to avoid any danger of suffocation by pulling it over head or putting it over face.
- Before using modelling colors or cement, open windows to keep the room well ventilated and do not use near fire or flame. After using them, keep in a proper place out of children.



주의  
WARNING!

**<READ THIS BEFORE YOU BEGIN>**

- Study the instructions before assembling. - Check the fit of each piece before cementing into place.
- Do not use too much cement to join parts. - Never use cement or paint near open flame.
- Open a window or make area well ventilated when cement or paint is in use.
- Tear up and throw away the empty plastic bags to avoid danger of suffocation for little children.



<READ THIS BEFORE YOU BEGIN>

<ALLGEMEINE HINWEISE>

<LISEZ CE QUI SUIT AVANT DE COMMENCER LE MONTAGE>

<組み立てる前に>

<조립하기 전에>

**<ALLGEMEINE HINWEISE>**

- Die Anordnung der Bauteile ist aus den Zeichnungen der Anleitung ersichtlich.
- Die Teile vor dem Verkleben ungeleimt zusammenhalten, um ihren paßsitz zu prüfen.
- Klebstoff nicht zu dick auftragen. - Klebstoff und Farben niemals in der Nähe einer Flamme verwenden.
- Während der Bemalung mit Spritzpistole oder Pinsel für frische Luftzufuhr, z.B. öffnen des Fensters, sorgen.
- Bausatz von kleinen Kindern fernhalten. Verhüten Sie, daß Kinder irgendwelche Bauteile in den Mund nehmen oder Plastiktüten über den Kopf ziehen.

**■ 조립하기 전에**

- 부품을 조립하기 전에 설명서를 잘 읽어본 후 조립한다.
- 접착하기 전에 부품을 맞추어 확인한 후 조립한다.

- 부품을 자를 때에는 칼이나 니퍼로 깨지 않도록 한다.
- 에나멜 페인트나 접착제를 사용할 때는 창문을 열어 환기를 시키고 화기를 멀리한다.
- 사용 후 남은 부품은 어린 아이들의 손에 닿지 않도록 잘 처리한다.

**<LISEZ CE QUI SUIT AVANT DE COMMENCER LE MONTAGE>**

- Etudier les schémas d'assemblage. - Contrôler que chaque pièce soit bien conforme avant de la coller à sa place.
- N'utilisez pas trop de colle pour réunir les pièces. - Ne faites manipuler la colle ou peinture à proximité d'une flamme.
- Aérer soigneusement la pièce où vous peignez (ouvrir la fenêtre).
- Après avoir sorti les pièces du sac en plastique, déchirer le sac afin d'éviter que les enfants ne le mettent sur la tête et ne s'étouffent.

**<組み立てる前に>**

- 組み立てる前に説明書をお読み下さい。 - 部品をランナーから切りはなす時は模型用ニッパーとカッターを使用します。
- 接着剤を少しなめに使うことがきれいに仕上げるコツです。 - 接着する前に部品を合わせて確かめます。
- 接着剤や塗料を使用する時はときどき窓を開けて換気に気をつけましょう。
- 組み立て後の部品やビニール袋は小さな子供の手の届かない安全な所に保管して下さい。

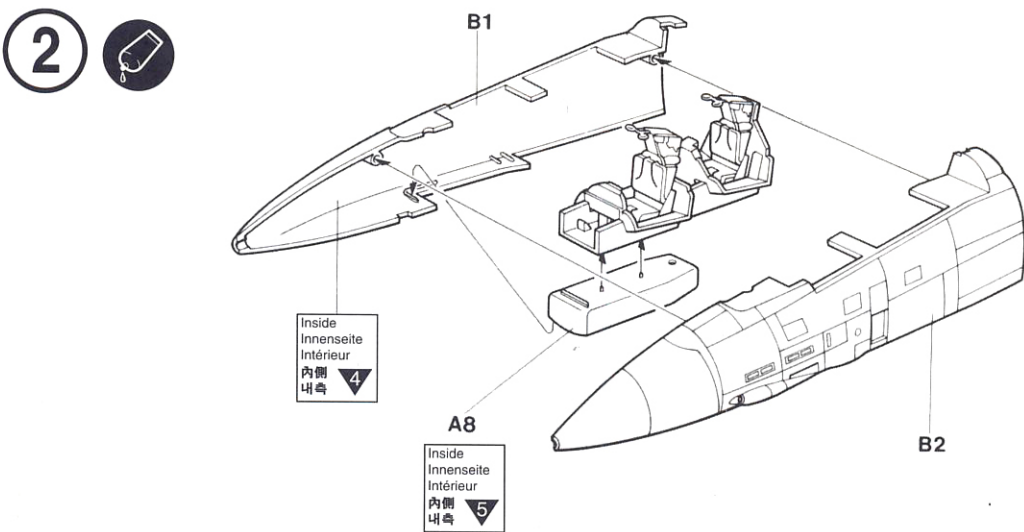
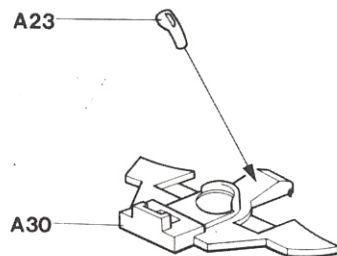
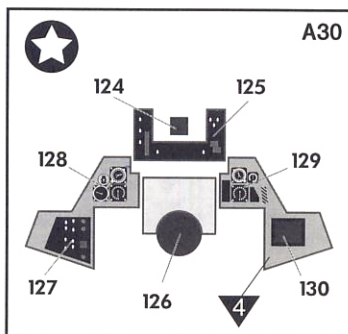
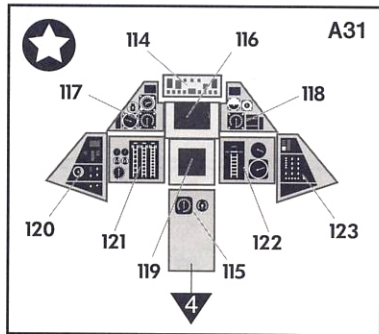
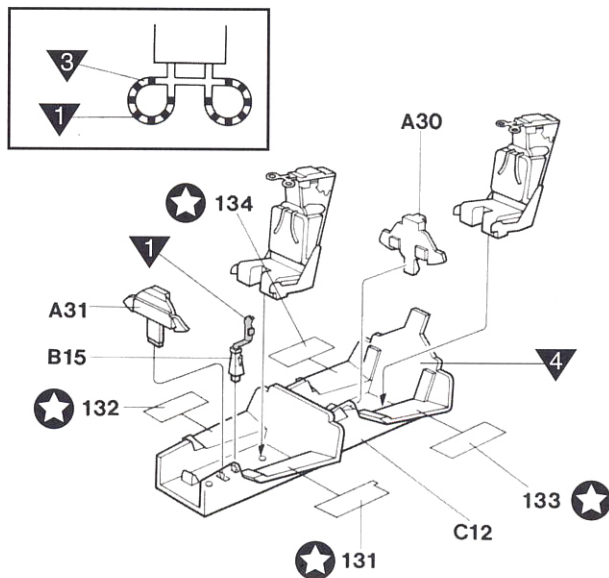
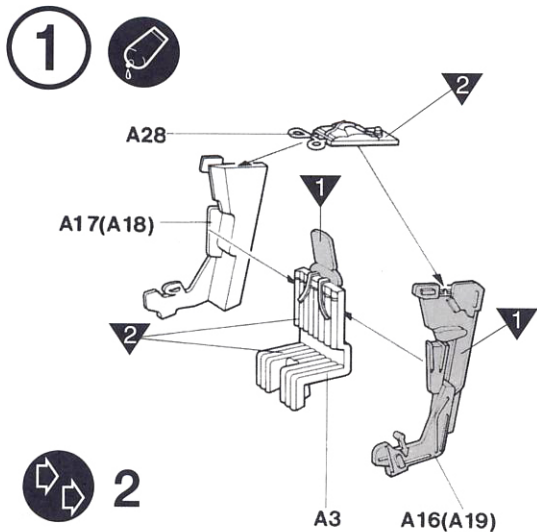

3

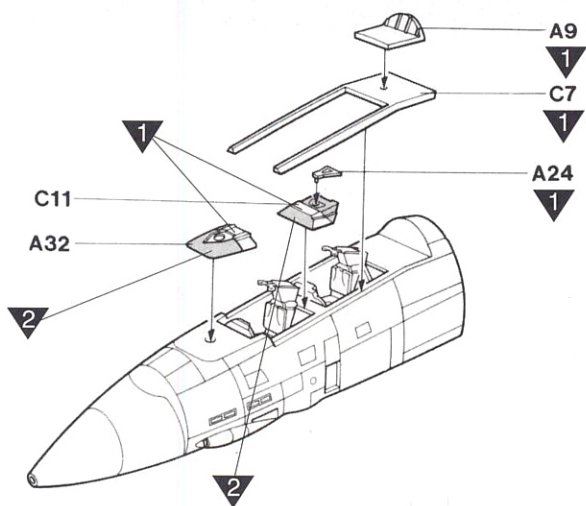

4

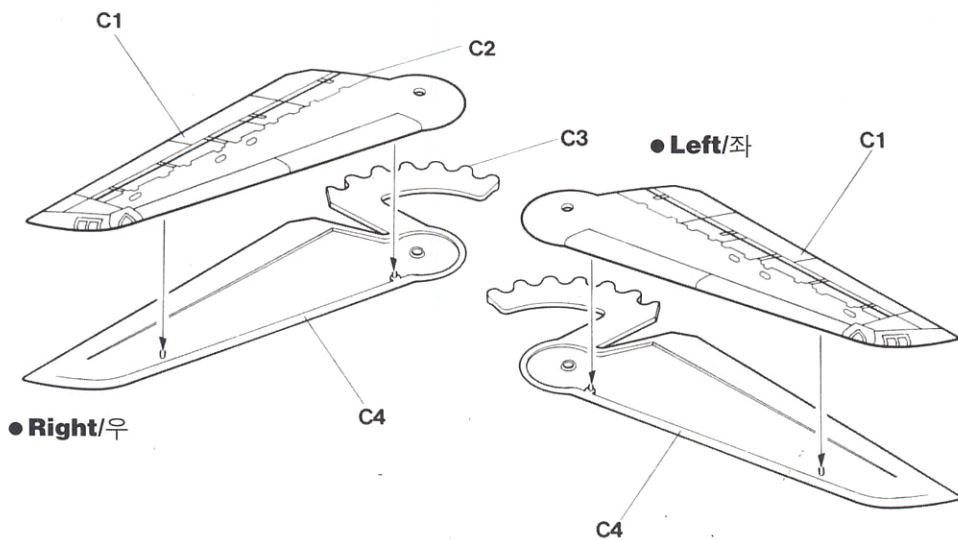

5

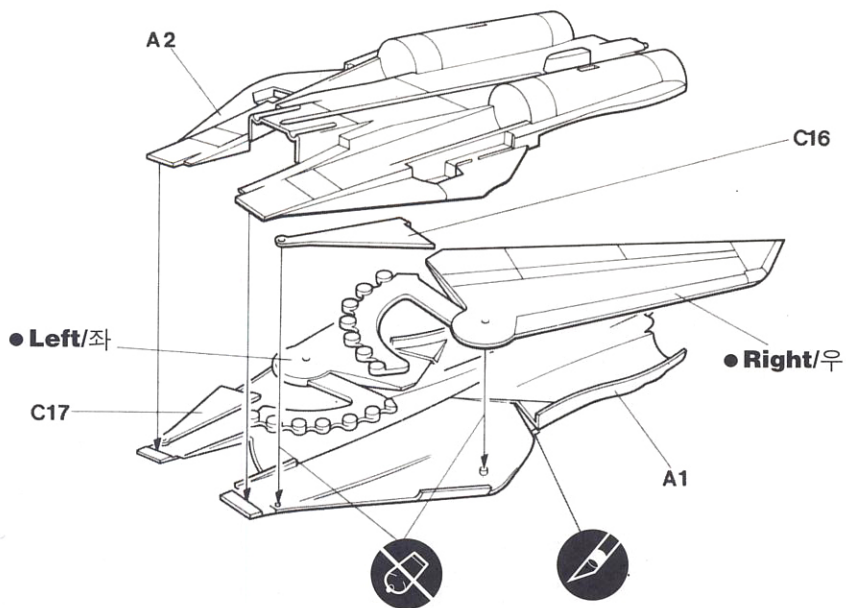
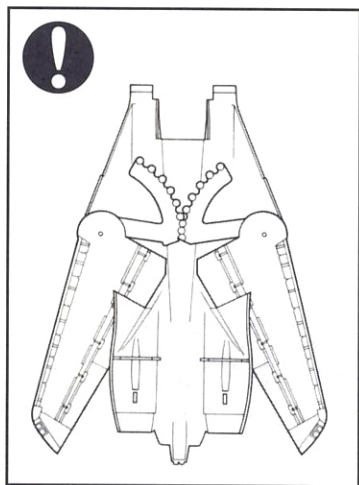

6 

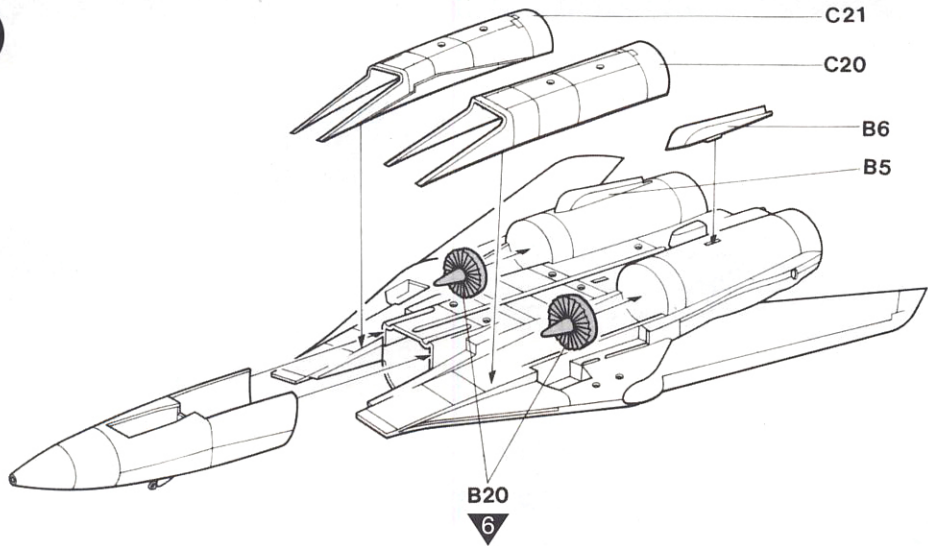

7  

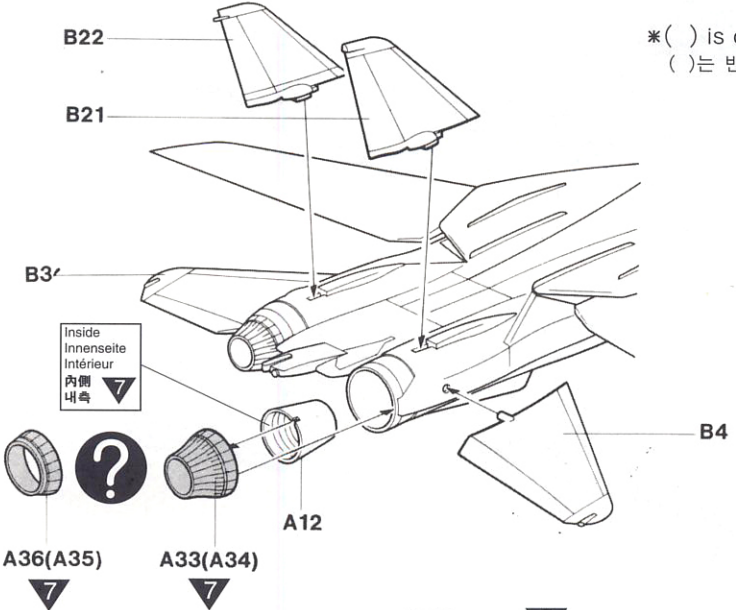

\* ( ) is opposite number.  
( )는 반대측 번호입니다.

8 

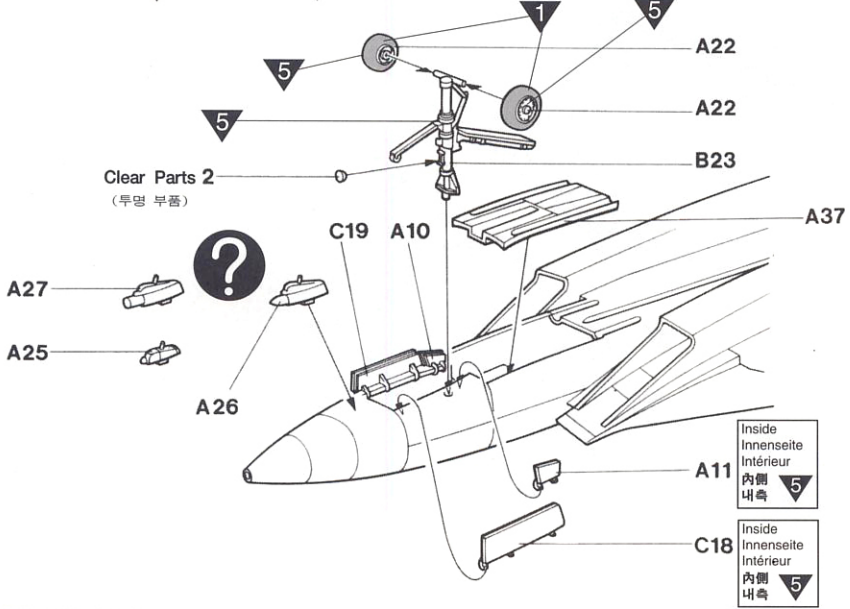



\* ( ) is opposite number.  
( )는 반대측 번호입니다.

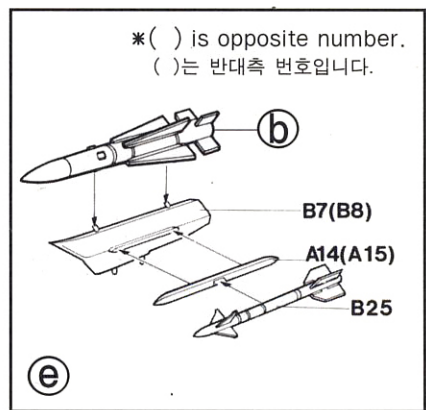
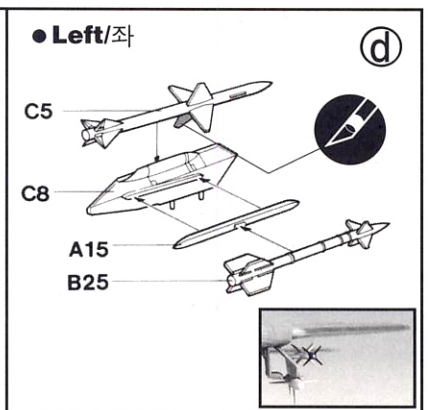
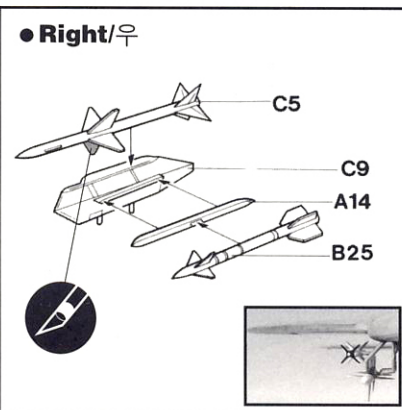
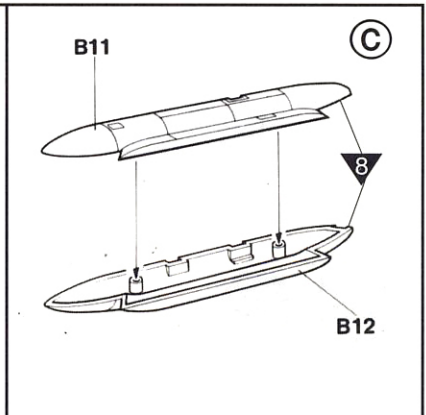
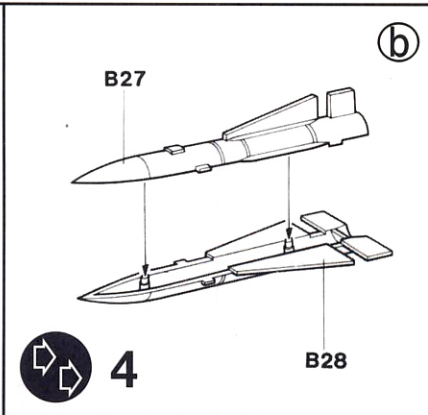
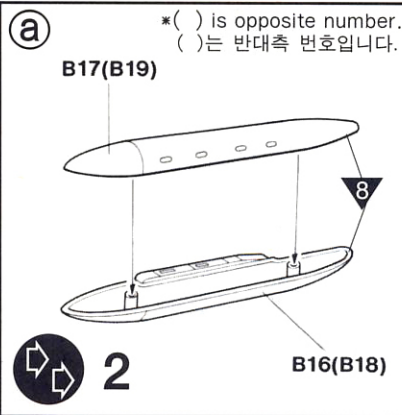
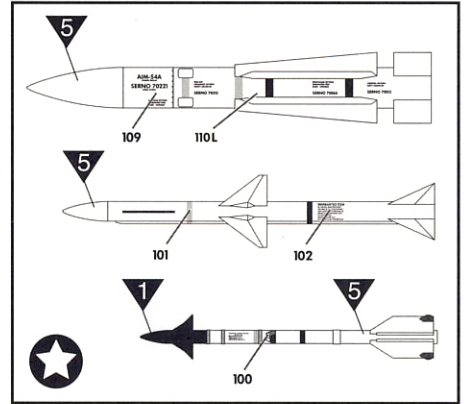
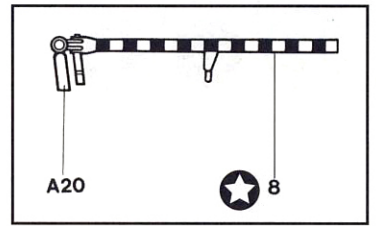
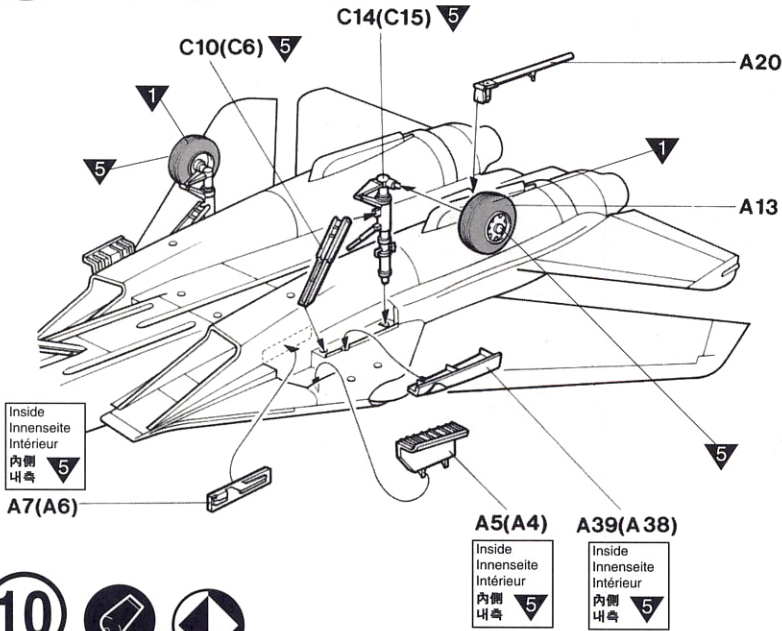

12

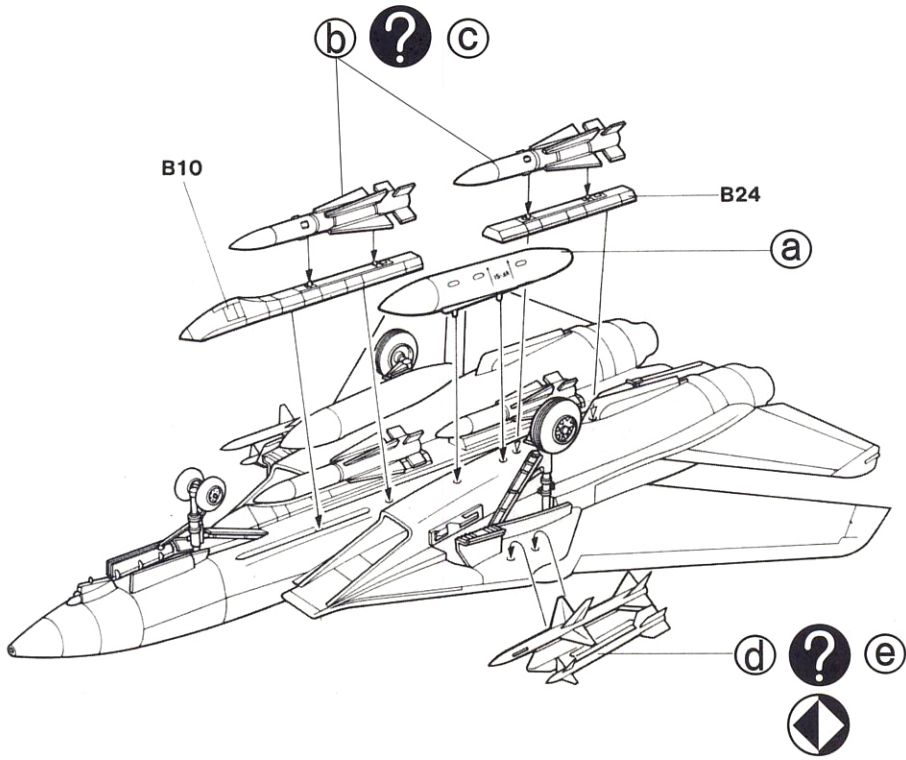

13

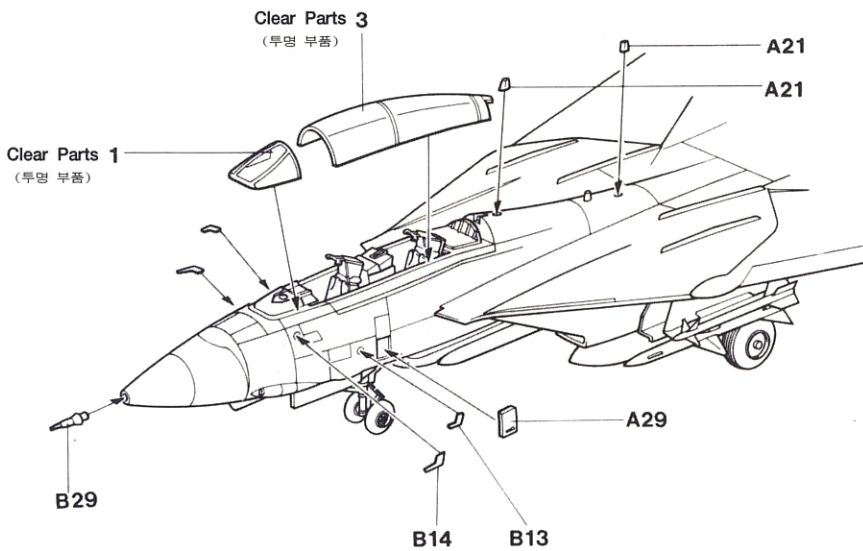

**F-14A, VF-84 'JOLLY ROGERS' AJ-202, 1980.**  
제84전투비행대 'JOLLY ROGERS' 소속 AJ-202기, 1980년.

**Body Color** 8  
기체색

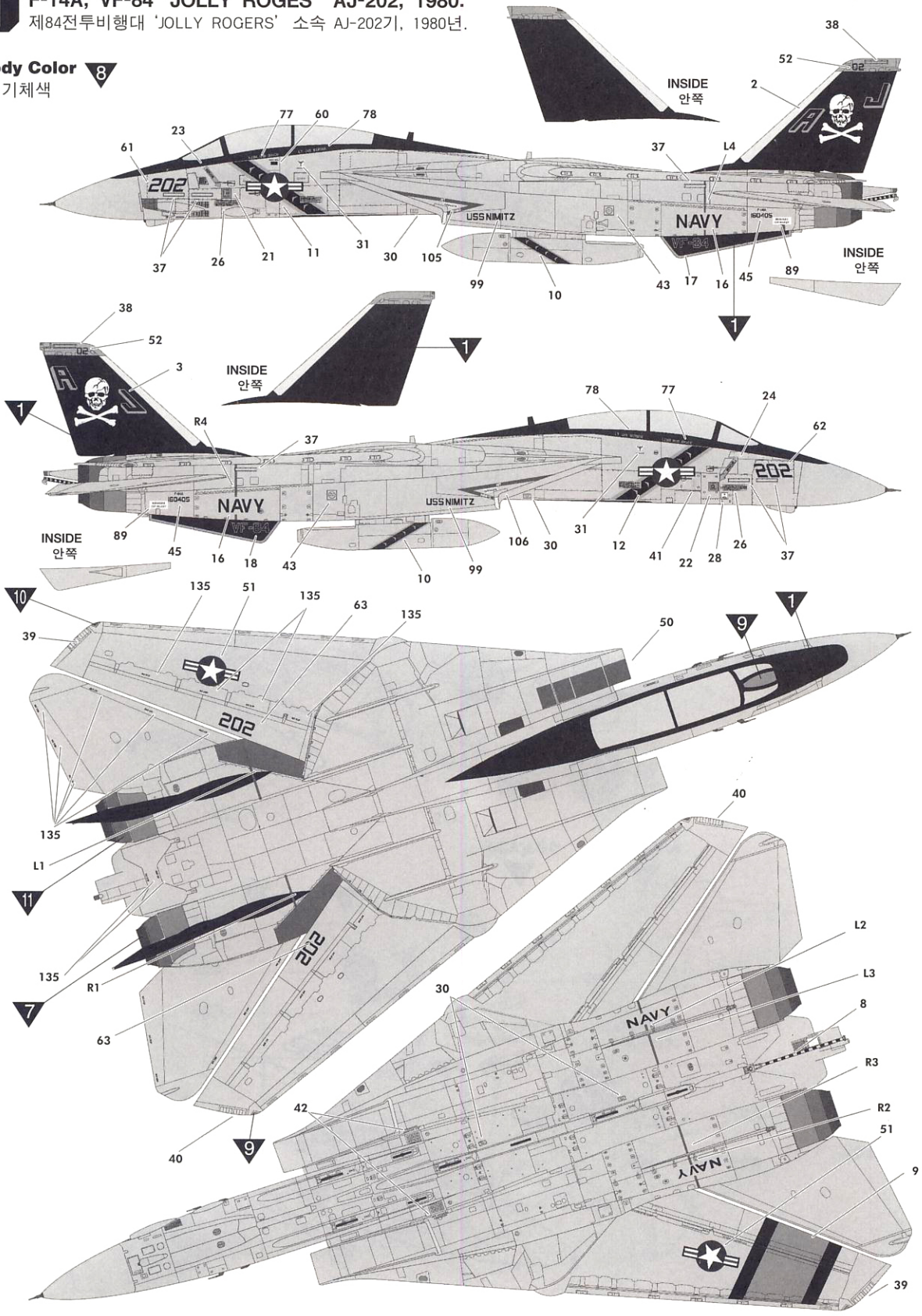

Painting & Decal placement 색칠 및 전사지 붙이기

**2** F-14A, VF-84 'JOLLY ROGERS' AJ-200, 1981.  
제84전투비행대 'JOLLY ROGERS' 소속 AJ-200기, 1981년.

**Body Color** 8  
기체색

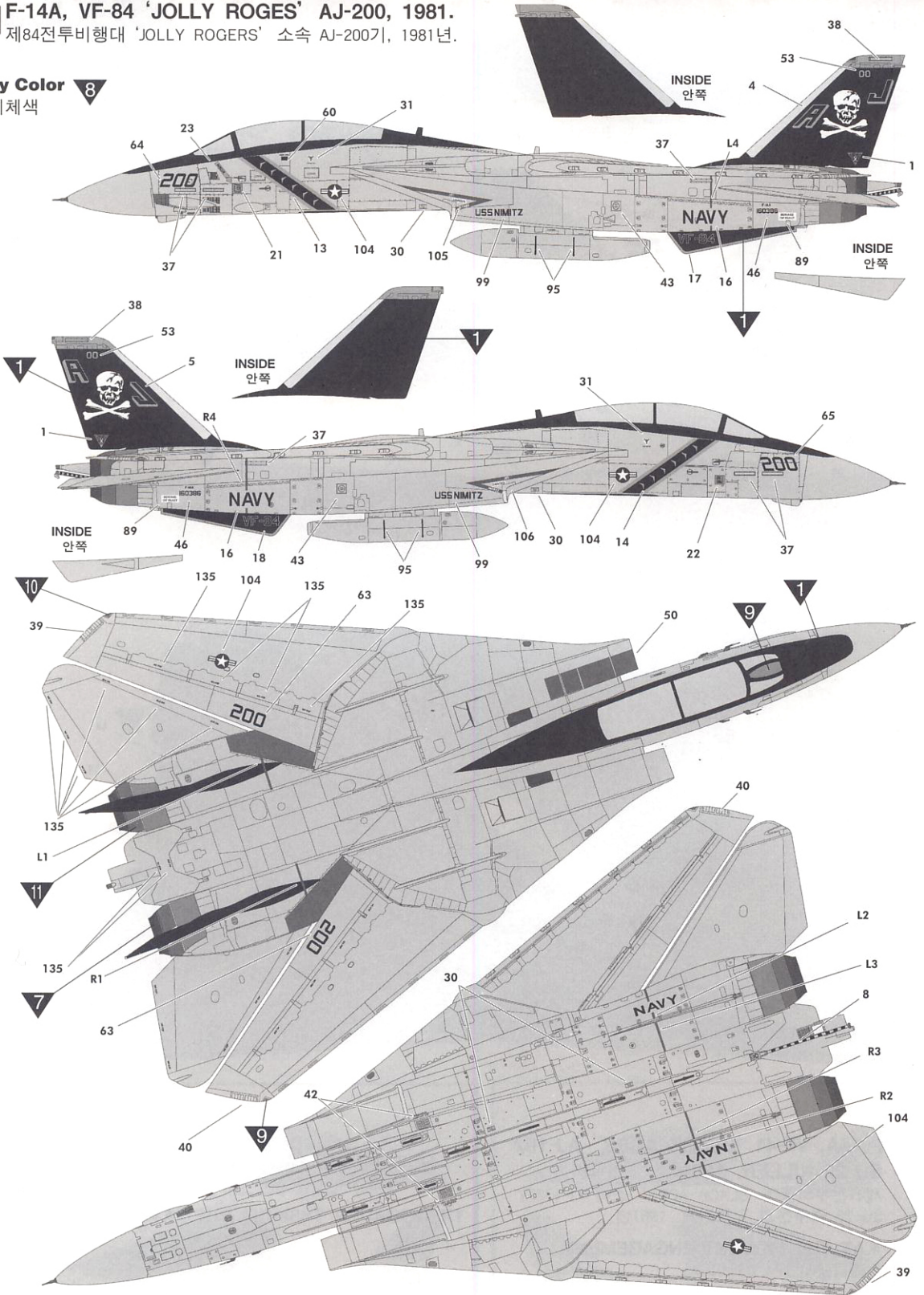







**5** F-14A, VF-101 'GRIM REAPERS' AD-101, 1982.  
제101전투비행대 'GRIM REAPERS' 소속 AD-101기, 1982년.

**Body Color**  
기체색

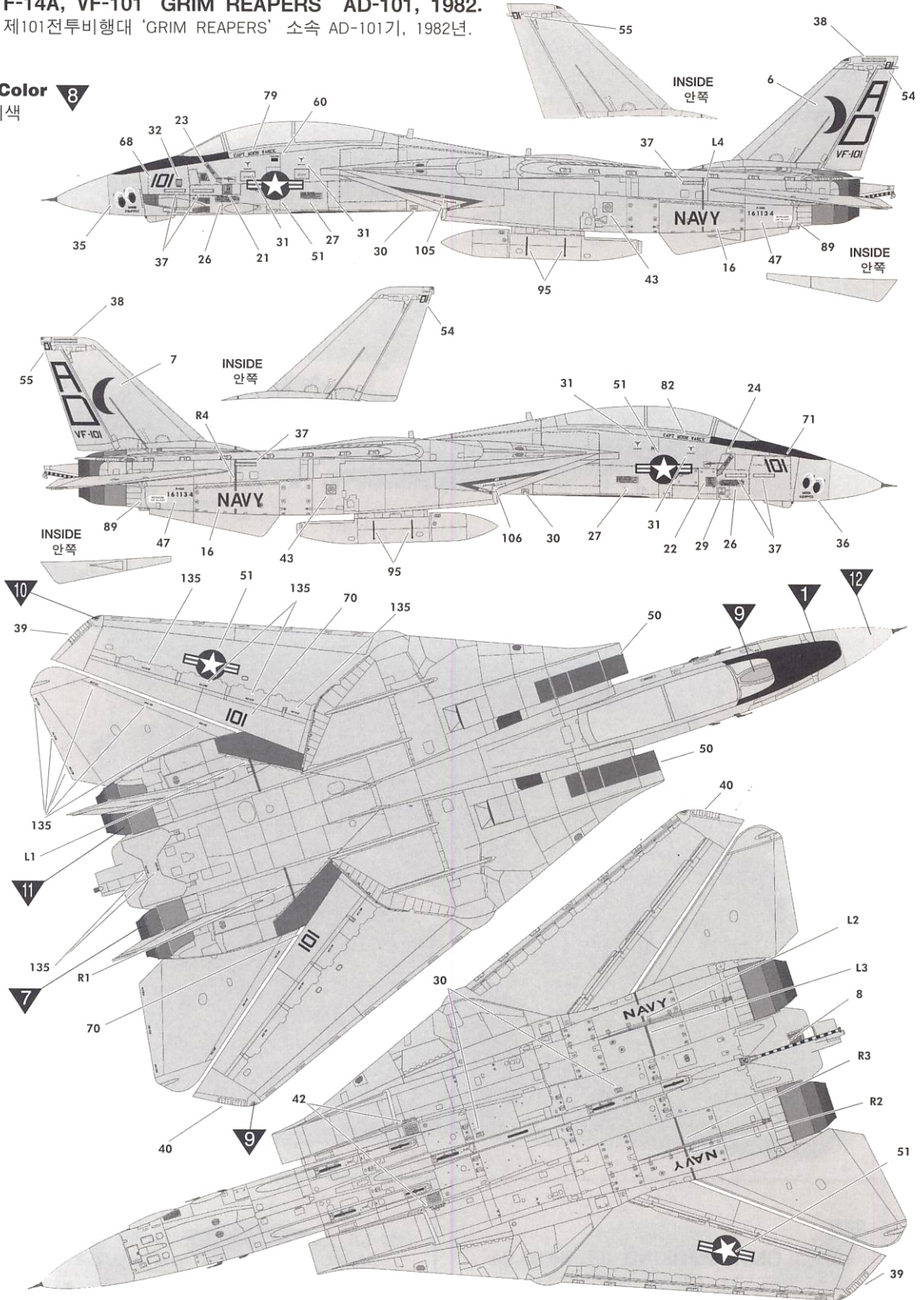

**A**

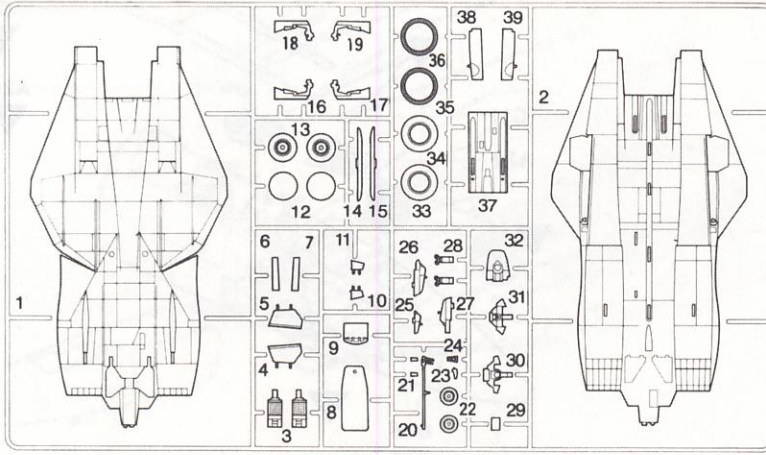

**B**

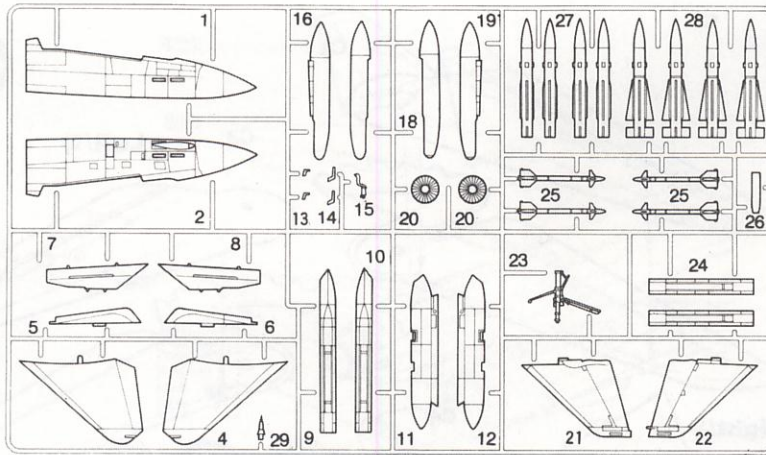

**C**

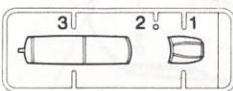
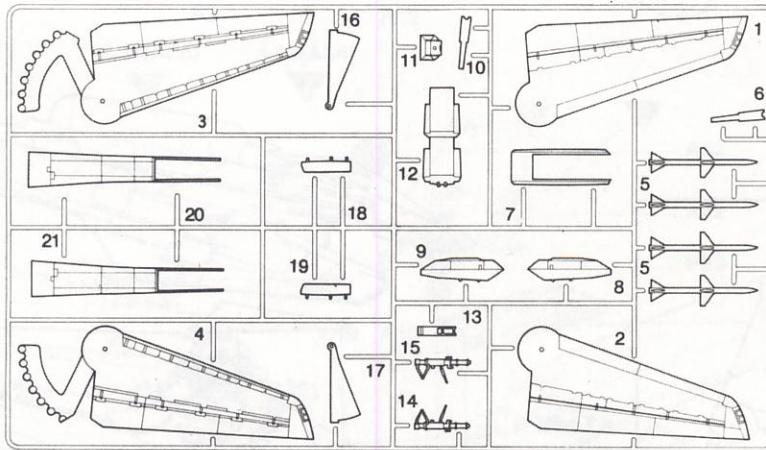

Crystal Clear x 1 (투명)

● Decal/전사지

● Unused parts/불필요 부품  
C13

**ACADEMY** **ACADEMY**  
ACADEMY PLASTIC MODEL CO., LTD.  
521-1, Yonghyeon-dong, Uijeongbu-si, Gyeonggi-do, Korea  
고객상담문의 : 080-969-7000