

**F-15A 75-0053, 53rd FS, 36th FW, Bitburg AB - Germany, July 1980**

Recommended Decals: PK Productions 48-001 Early Eagle Stencils, use Stencil Style I + Panel Numbers

Recommended Kit: Hasegawa F-15C

For the grey canopy frame use M49

For the red canopy frame use M48

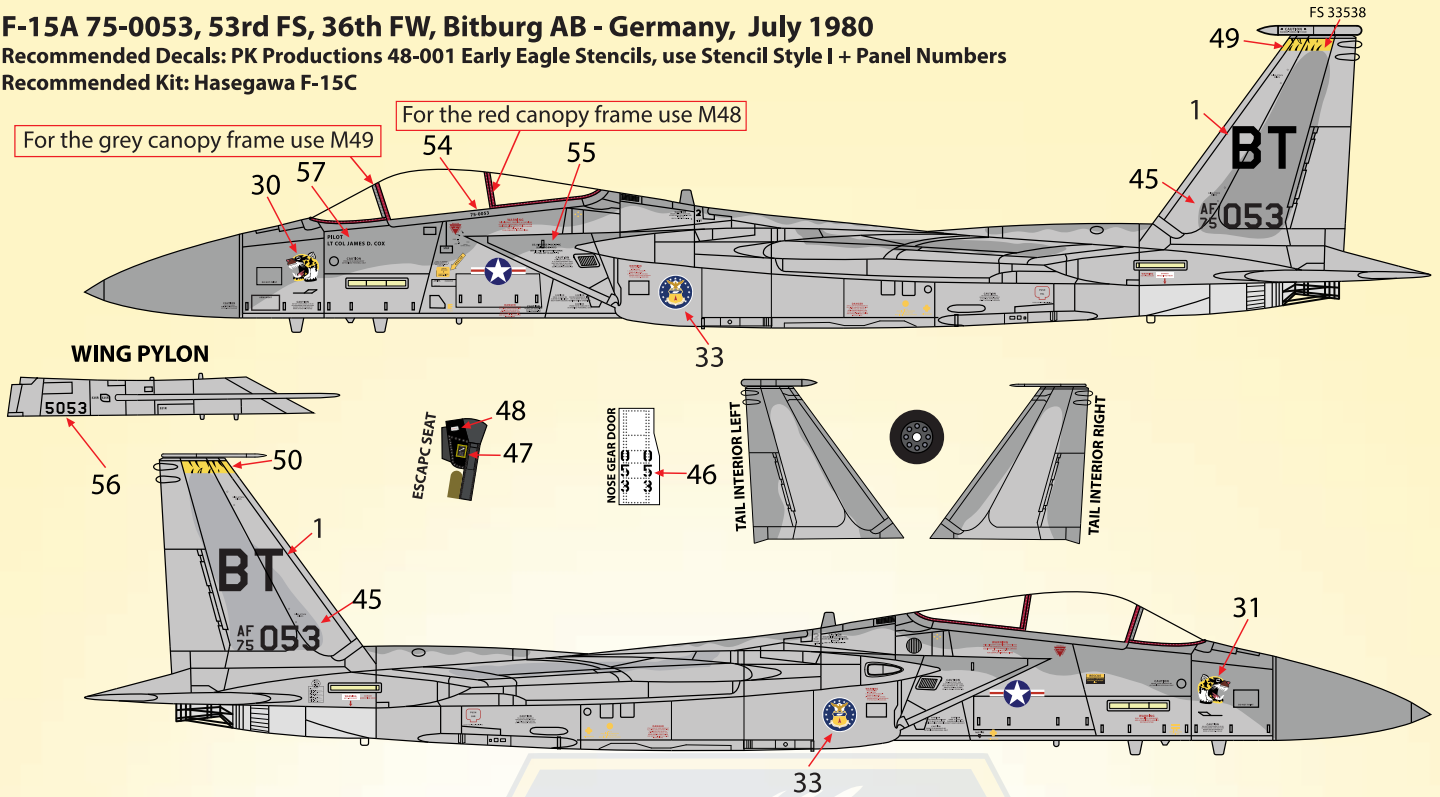

**F-15B 75-0088, 53rd FS, 36th FW, Bitburg AB - Germany, July 1980**

Recommended Decals: PK Productions 48-001 Early Eagle Stencils, use Stencil Style I + Panel Numbers

Recommended Kit: Great Wall Hobby F-15B/D

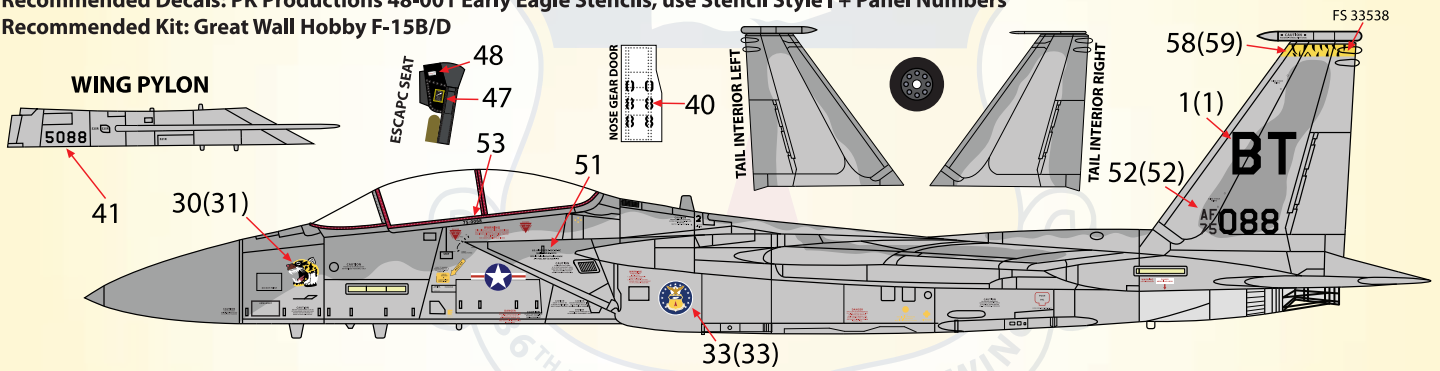

**F-15C 80-009, 22nd FS, 36th FW, Strasbourg-Entzheim - France, July 1984**

Recommended Decals: PK Productions 48-001 Early Eagle Stencils, use Stencil Style I + Panel Numbers

Recommended Kit: Hasegawa F-15C

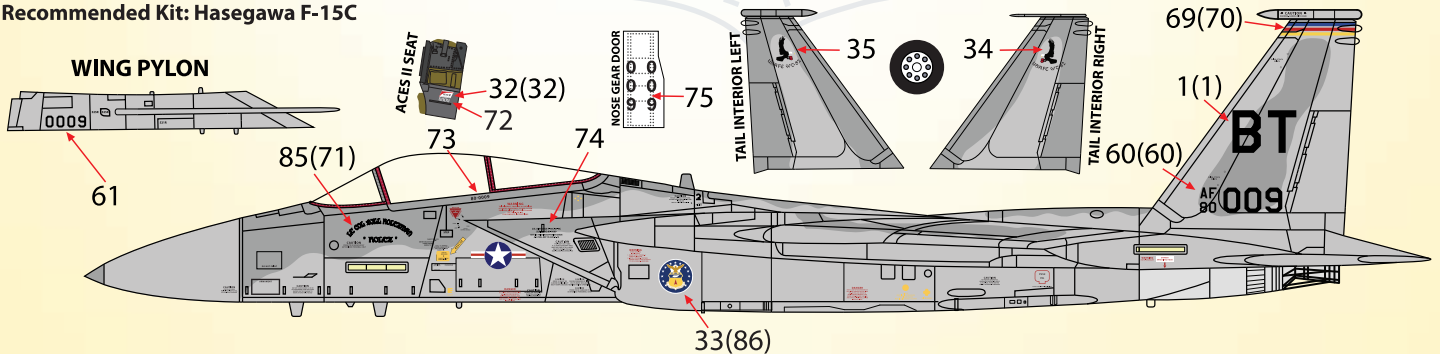

**F-15C 79-0050 525th FS, 36th FW, Neuburg AB - Germany, September 1986**

Recommended Decals: PK Productions 48-001 Early Eagle Stencils, use Stencil Style I

Recommended Kit: Hasegawa F-15C

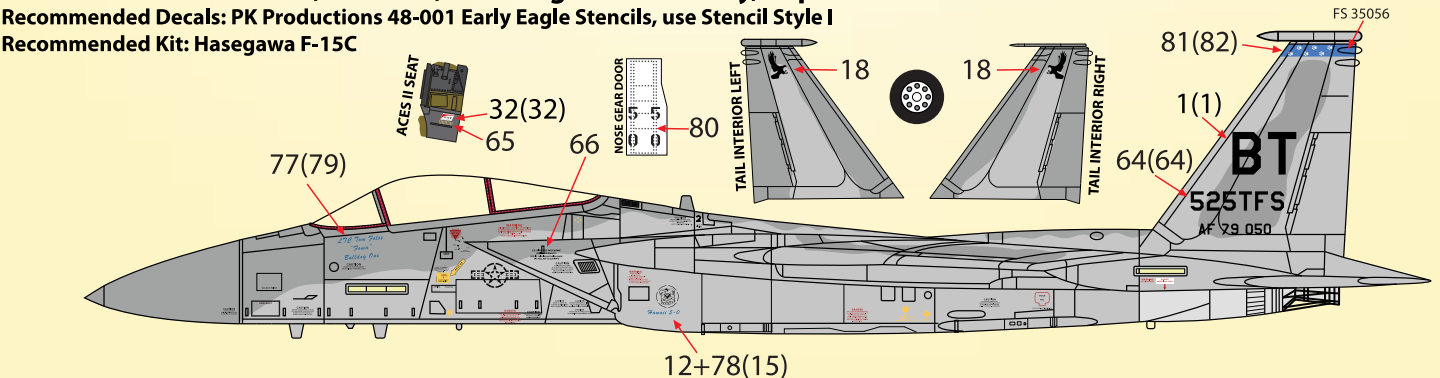

**F-15C 79-0043 525th FS, 36th FW, Bitburg AB - Germany, August 1986**

Recommended Decals: PK Productions 48-001 Early Eagle Stencils, use Stencil Style I

Recommended Kit: Hasegawa F-15C

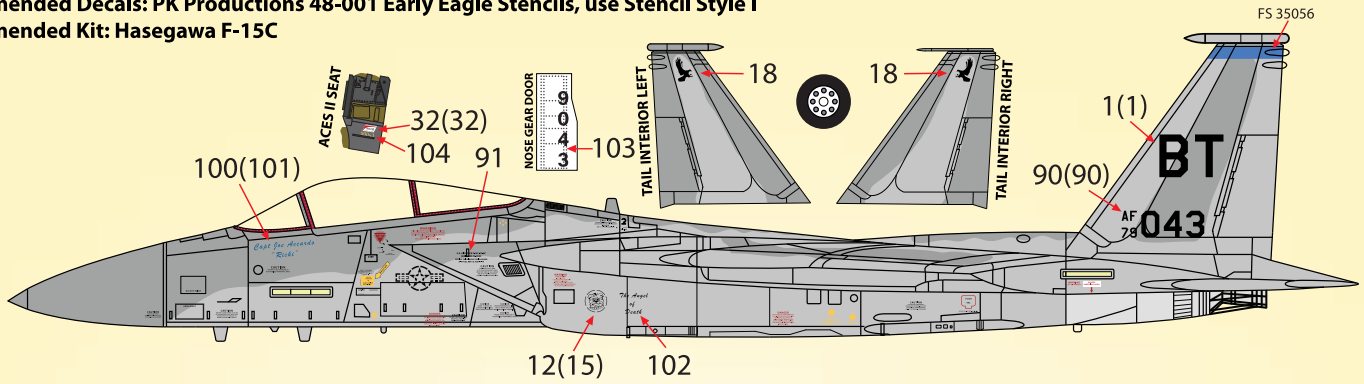

**F-15C 80-0019 525th FS, 36th FW, Bitburg AB - Germany, August 1986**

Recommended Decals: PK Productions 48-001 Early Eagle Stencils, use Stencil Style I

Recommended Kit: Hasegawa F-15C

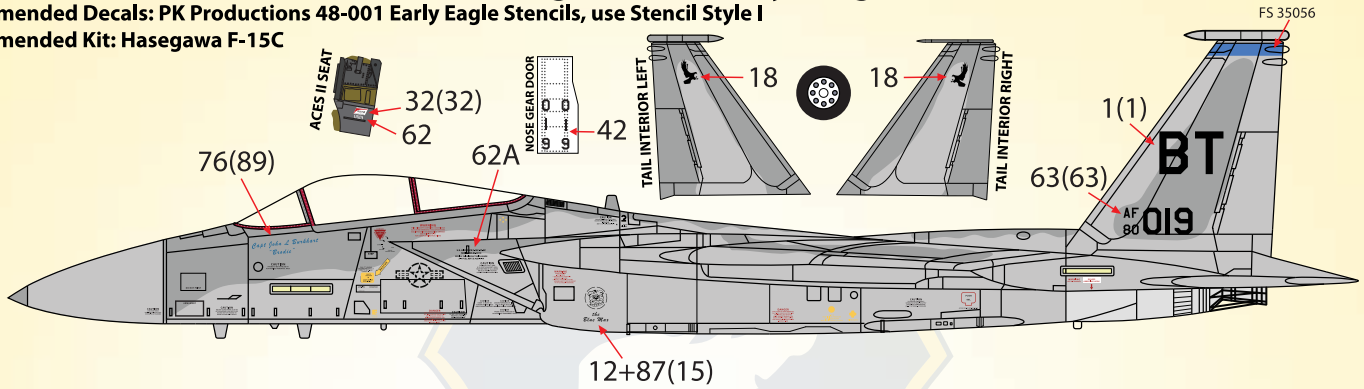

**F-15C 80-0013 53rd FS, 36th FW, Bitburg AB - Germany, September 1986**

Recommended Decals: PK Productions 48-001 Early Eagle Stencils, use Stencil Style I + Panel Numbers

Recommended Kit: Hasegawa F-15C

This is the Eagle of Capt. Greg "The Claw" Clasen, who is known from the movie "The Wing" about Bitburg Air Base.

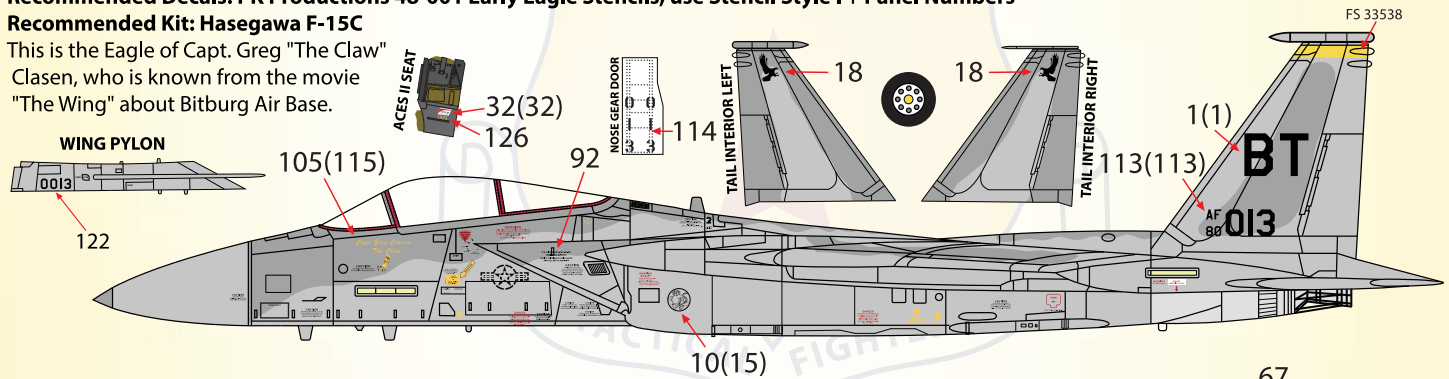

**F-15C 84-0001 53rd Fighter Squadron, Bitburg AB - Germany, September 1989**

Recommended Decals: PK Productions 48-001 Early Eagle Stencils, use Stencil Style I mixed with Style II

Recommended Kit: Hasegawa F-15C

For the grey canopy frame use M49

For the red canopy frame use M48

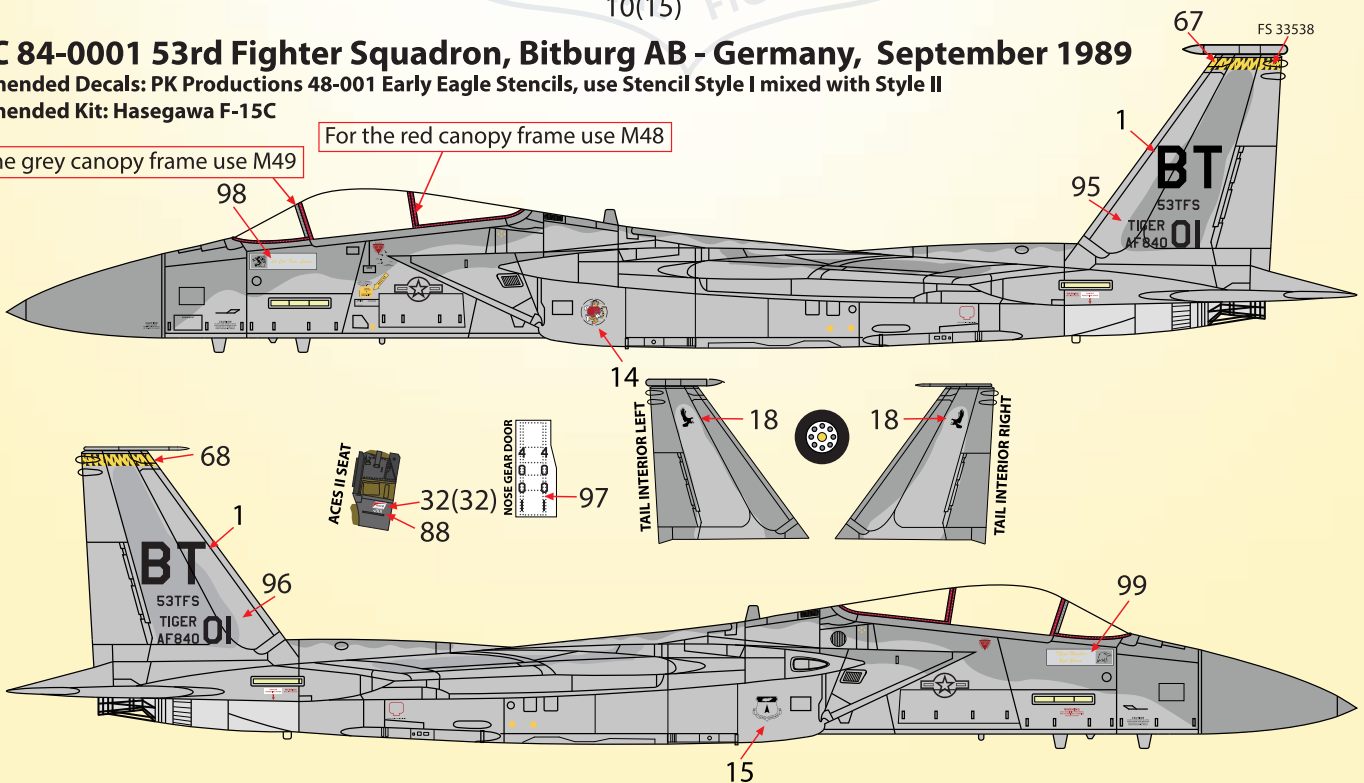

**F-15C MSIP II 79-0036, 36th FW, Bitburg AB - Germany, April 1993**

Recommended Decals: PK Productions 48-001 Early Eagle Stencils, use Stencil Style II

Recommended Kit: Great Wall Hobby F-15C

For the red canopy frame use M48

For the grey canopy frame use M49

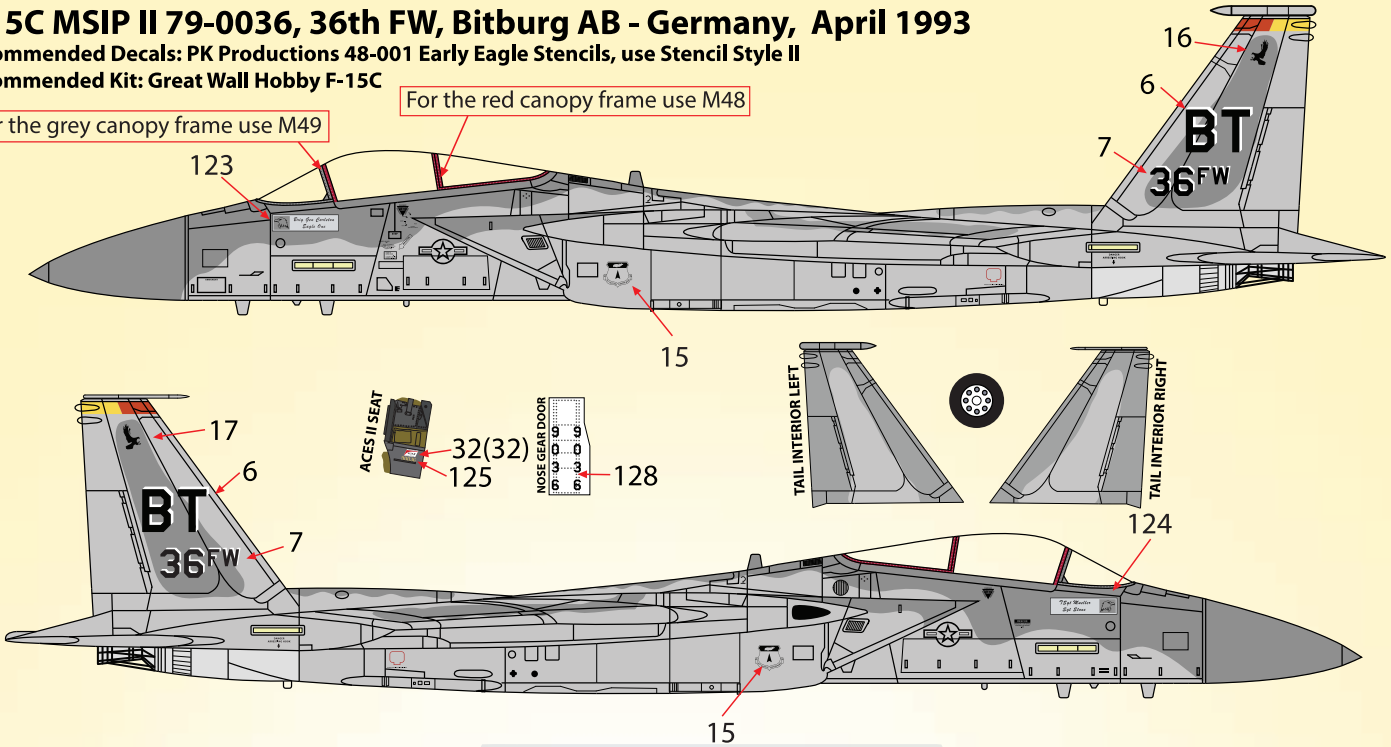

**F-15C MSIP II 79-0078, 22nd, 36th FW, Al-Kjarj AB - Saudi Arabia, February 1991**

Recommended Decals: PK Productions 48-001 Early Eagle Stencils, use Stencil Style II

Recommended Kit: Great Wall Hobby F-15C

During operation "Desert Storm" on the 06 Feb. 1991 Capt. Thomas Nicolas "Vegas" Dietz of the 53rd FS, achieved two kills with the 79-0078.

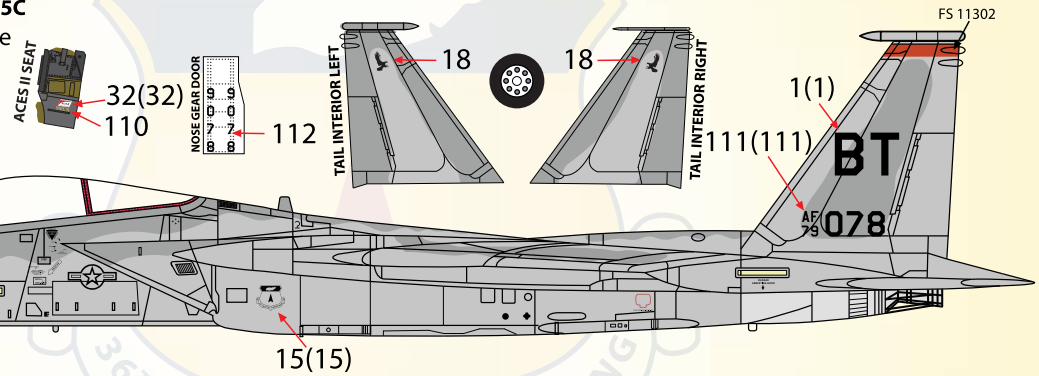

**F-15C MSIP II 84-0010, 53rd FS, 36th FW, Aviano AB - Italy, August 1993**

Recommended Decals: PK Productions 48-001 Early Eagle Stencils, use Stencil Style II

Recommended Kit: Great Wall Hobby F-15C

Following the shoot down of two enemy aircraft that earned Captain Dietz the Silver Star, on March 24, 1991, he shot down a third enemy airplane with this eagle, making him one of only three airmen since the end of the Vietnam War to achieve THREE aerial victories.

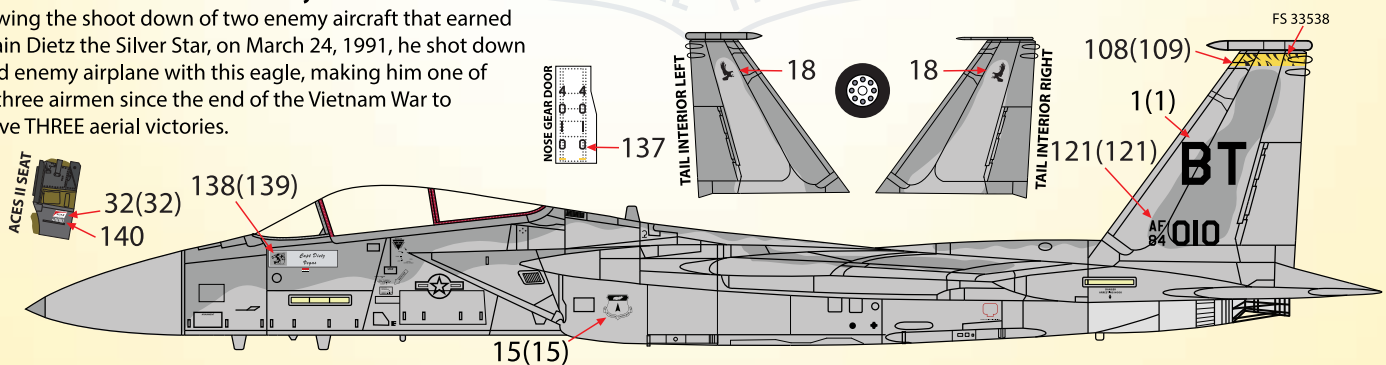

**F-15C MISP II 84-0022, 22nd FS, 36th FW, Bitburg AB - Germany, June 1993**

Recommended Decals: PK Productions 48-001 Early Eagle Stencils, use Stencil Style II

Recommended Kit: Great Wall Hobby F-15C

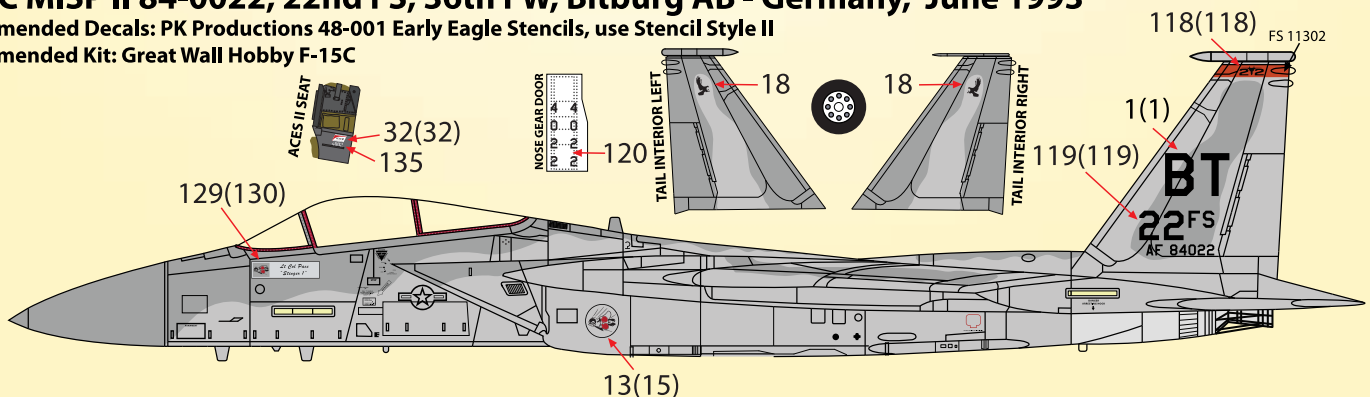



**F-15C MISP II 84-0009, 36th FW, Bitburg AB - Germany, September 1993**

Recommended Kit: Great Wall Hobby F-15C

For the grey canopy frame use M49

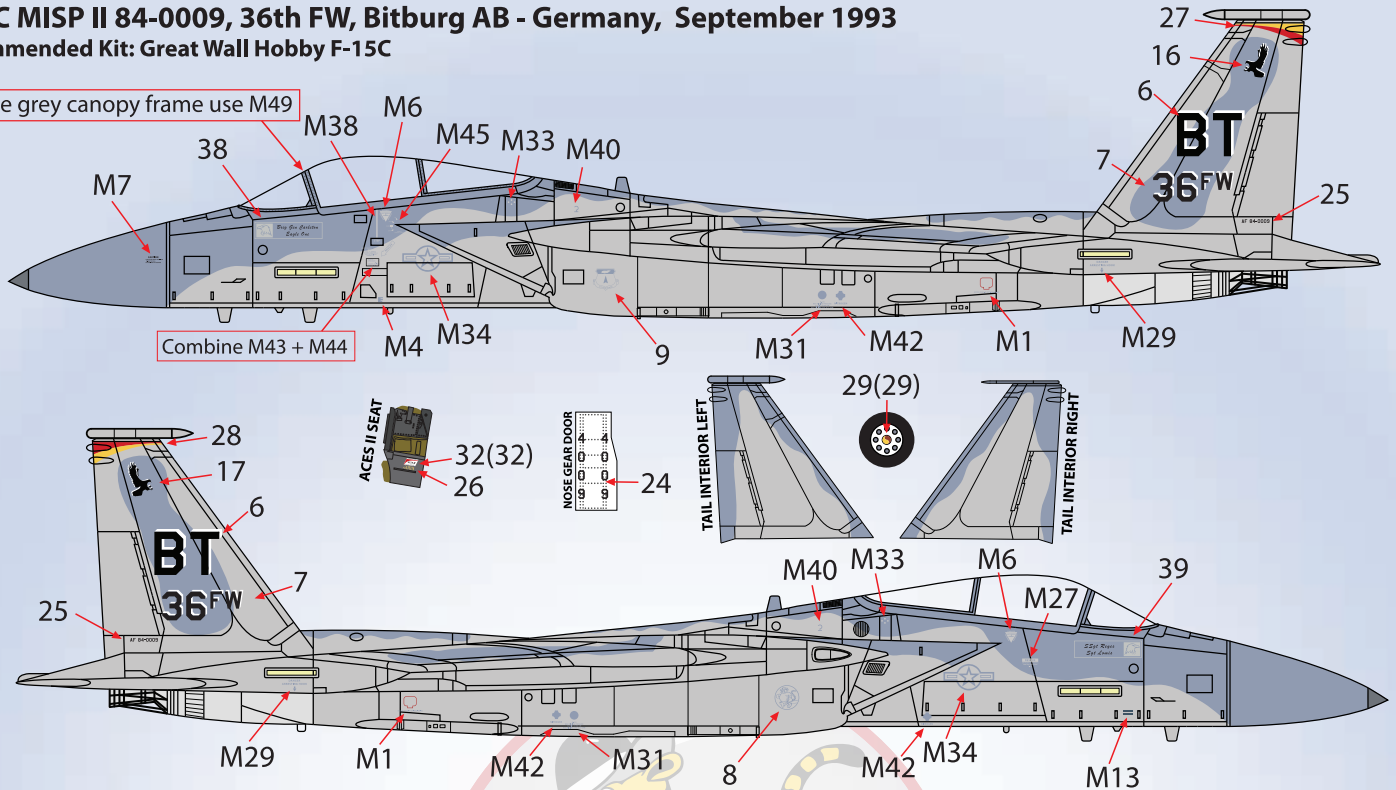

**F-15C MISP II 84-0008, 53rd FS, 36th FW, Kleine Brogel AB - Belgium, September 1993**

Recommended Decals: PK Productions 48-001 Early Eagle Stencils, use Stencil Style II

Recommended Kit: Great Wall Hobby F-15C

For the grey canopy frame use M49

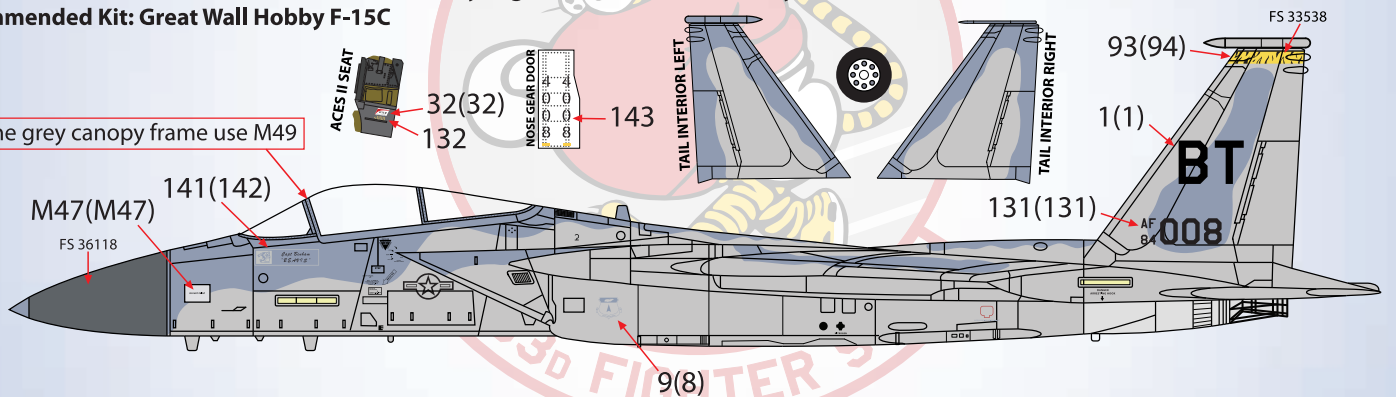

**F-15C MISP II 84-0001 53rd FS, 36th FW, Aviano AB - Italy, Juni 1993**

Recommended Kit: Great Wall Hobby F-15C

For the red canopy frame use M48

Use M27 on other side

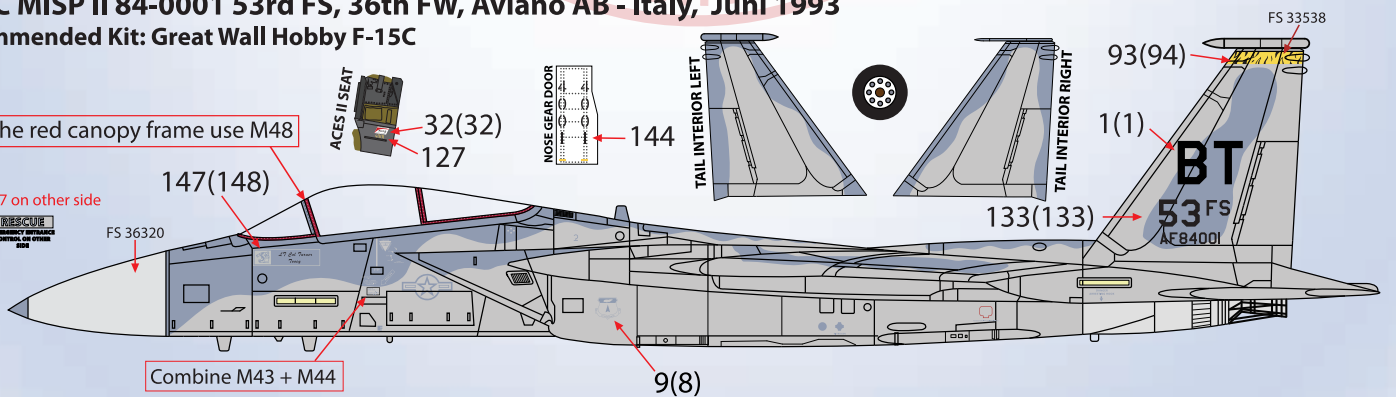

**F-15C MISP II 84-0016 53rd, 36th FW, Bitburg AB - Germany, Juni 1993**

Recommended Kit: Great Wall Hobby F-15C

For the red canopy frame use M48

Use M27 on other side

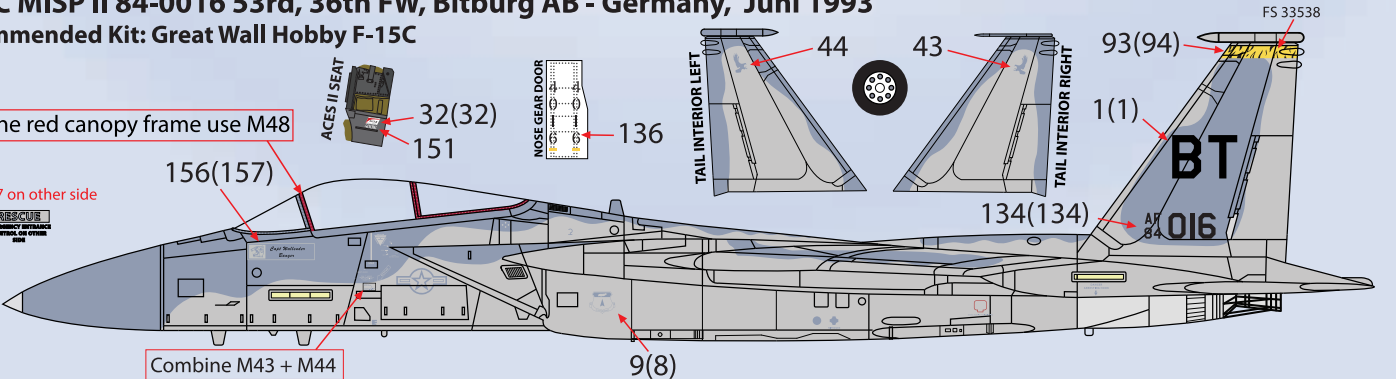

**F-15C MISP II 80-0052, 52nd FW, Spangdahlem AB - Germany, August 1995**

Recommended Kit: Great Wall Hobby F-15C

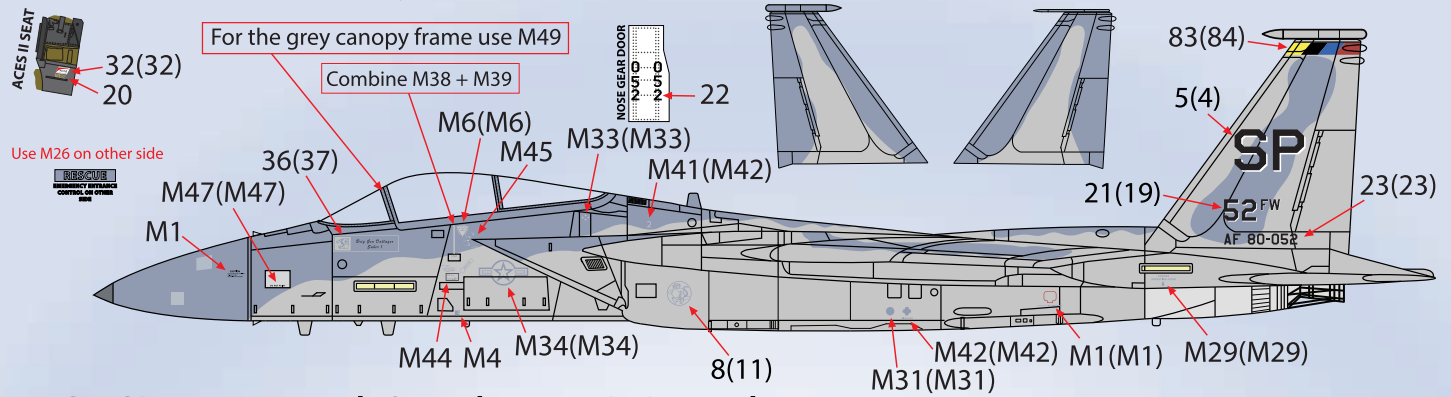

**F-15C MISP II 84-0027, 53rd FS, 52nd, Karup AB - Denmark, August 1995**

Recommended kit: Great Wall Hobby F-15C

During operation "Desert Storm" on the 27 Jan. 1991 Capt. Benjamin Dean "Coma" Powell of the 53rd FS, achieved two kills with the 84-0027.

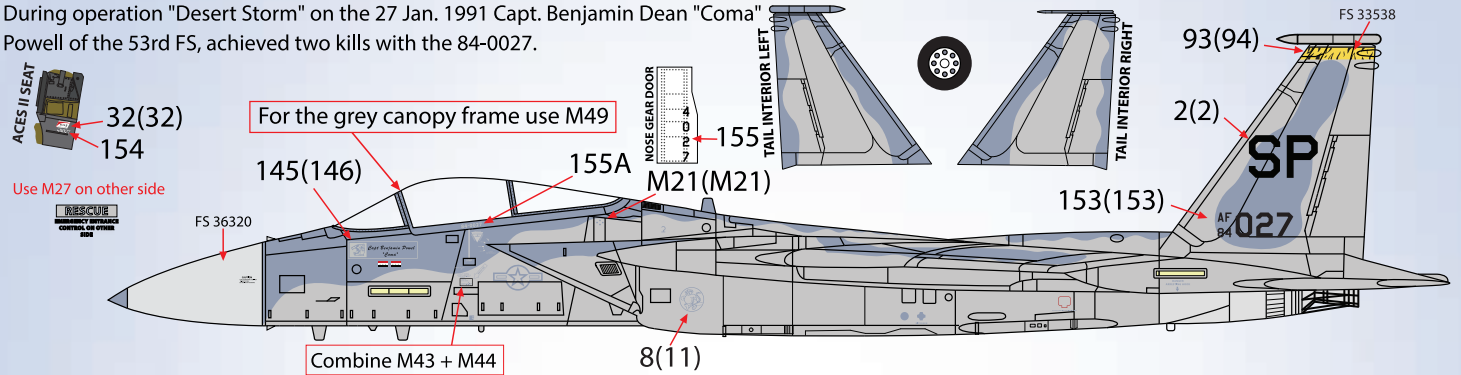

**F-15C MISP II 79-0068, 53rd FS, 52nd, Spangdahlem AB - Germany, May 1995**

Recommended Kit: Great Wall Hobby F-15C

In memory of Major Donald "Zane" Lowry who was killed when his F-15C crashed at Spangdahlem AB on the 30 May 1995.

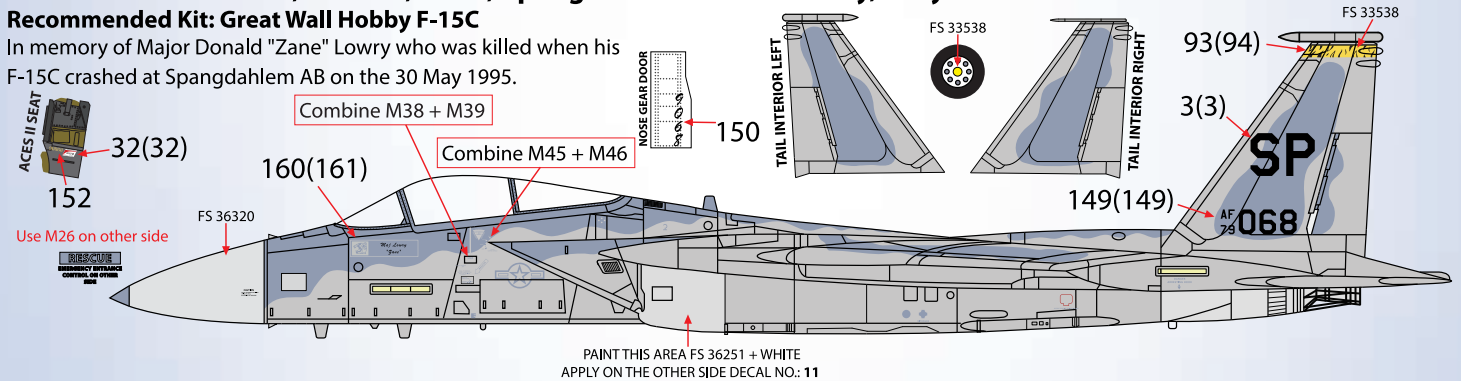

**F-15C MISP II 84-0023, 53rd FS, 52nd FW, Spangdahlem AB - Germany, September 1996**

Recommended Kit: Great Wall Hobby F-15C

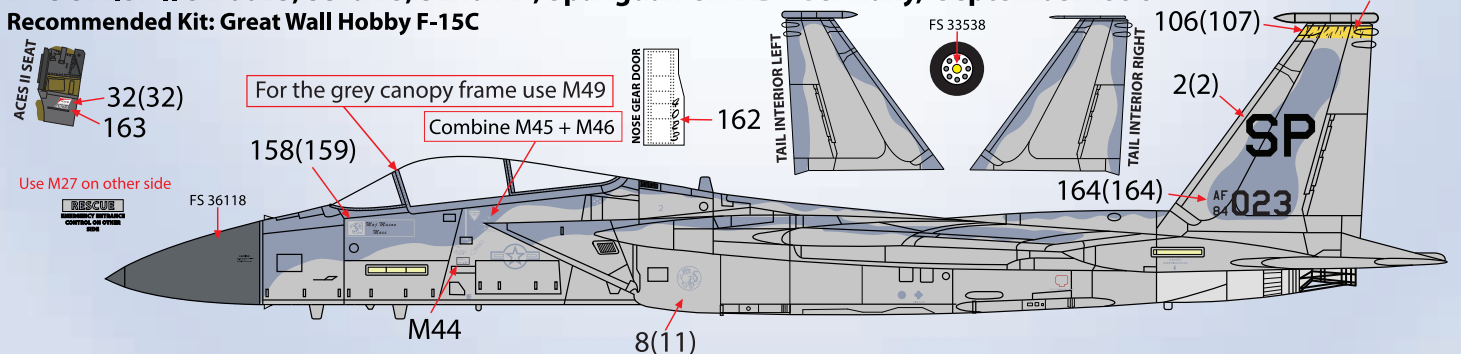

**F-15D MISP II 79-0012, 53rd FS, 52nd FW, Spangdahlem AB - Germany, July 1997**

Recommended Kit: Great Wall Hobby F-15C

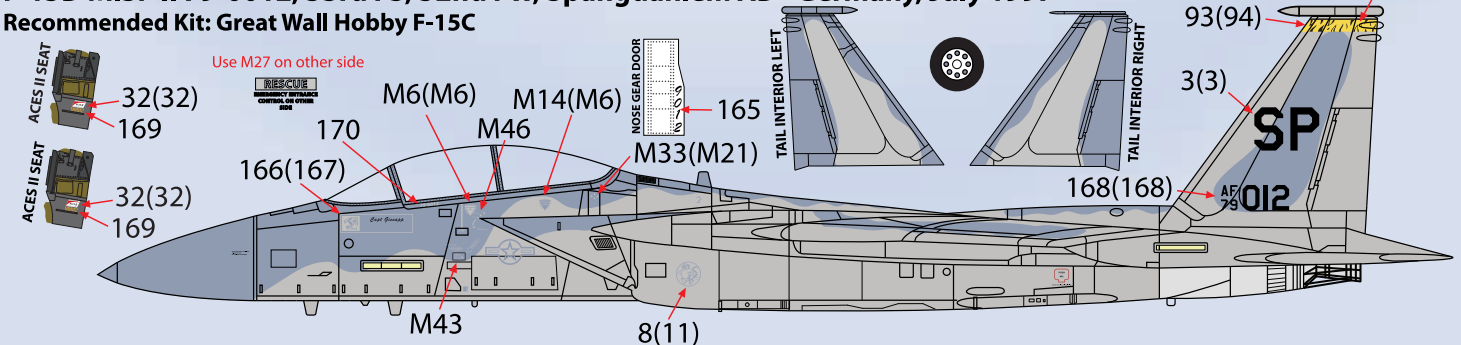

Mod Eagle Stencils Top side



FS36176 HATAKA HTK-C158  
Mod Eagle Grey



FS36251 HATAKA HTK-C157  
Aggressor Grey

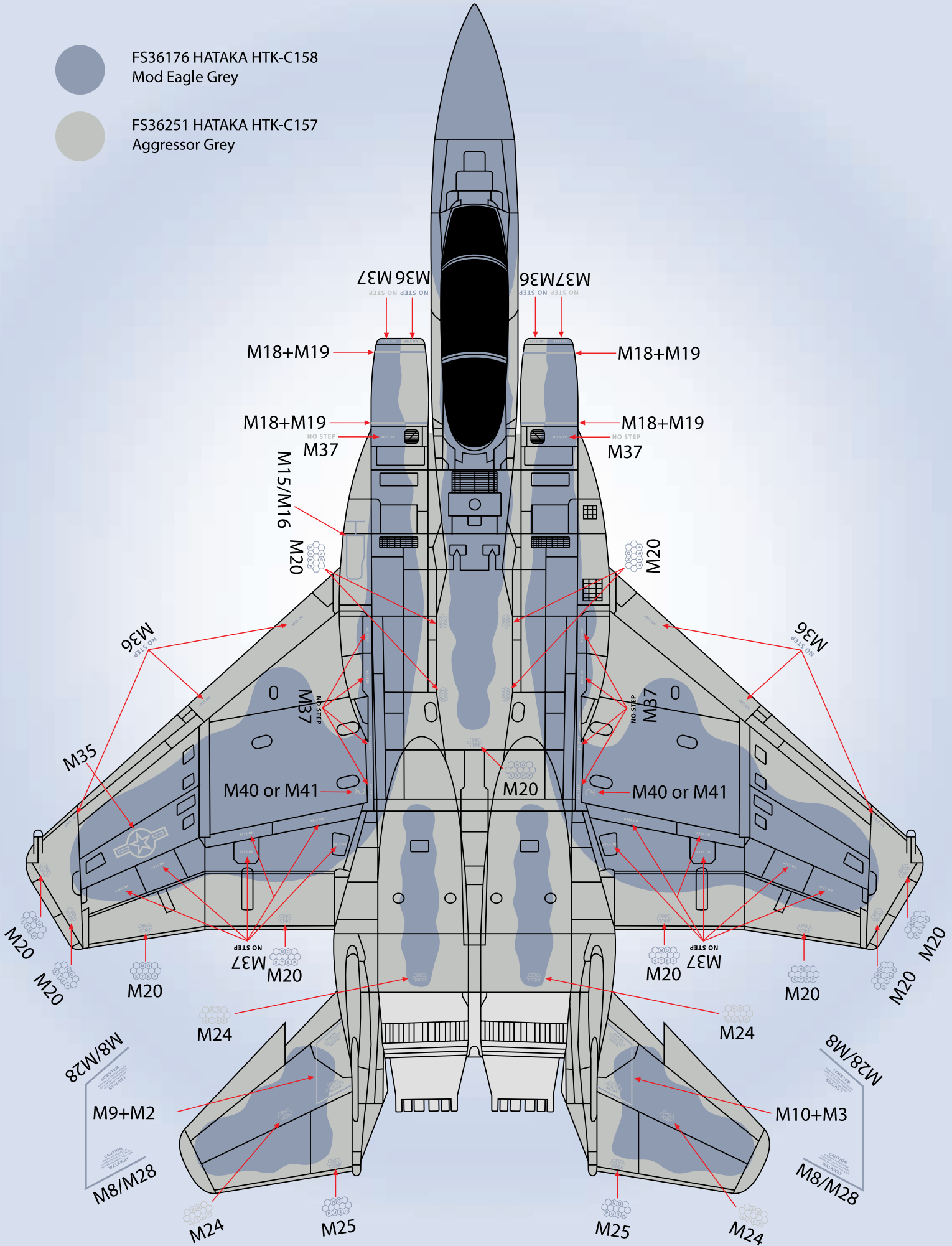

Mod Eagle Stencils Bottom

- FS36176 HATAKA HTK-C158  
Mod Eagle Grey
- FS36251 HATAKA HTK-C157  
Aggressor Grey

