

Me
**HISTORY
MAKERS**TM
Revell

German V-2 Missile

Assembly Instructions

LIMITED PRODUCTION SERIES

LIMITED PRODUCTION SERIES

LIMITED PRODUCTION SERIES

LIMITED PRODUCTION SERIES

LIMITED PRODUCTION SERIES

LIMITED PRODUCTION SERIES

LIMITED PRODUCTION SERIES

LIMITED PRODUCTION SERIES

LIMITED PRODUCTION SERIES

LIMITED PRODUCTION SERIES



The V-2, or more properly, the A-4 rocket was used extensively against London in 1944 and later against Allied supply and communication centers in Brussels and Liege. It was the first operational use of an intermediate range ballistic missile, and represented the turning point in modern warfare.

Although much of the basic research in liquid propelled rockets had been done by an American, Dr. Robert H. Goddard, in the years following World War I, it remained for the Germans, working to evade the restrictions of the Treaty of Versailles, to develop rocketry as a military weapon. Germany had been prevented by the Treaty from rearming, but the prospect of rockets as a possible military threat had not been considered by the men who drew up the treaty, and therefore were not mentioned. This loophole was not overlooked by the German Military, who worked with great determination to perfect this kind of weapon.

Having rejected solid propellants for a variety of technical reasons, Wernher von Braun and a team of rocket engineers were working as early as 1930 on a practical liquid rocket engine. Much of this work, although von Braun was a civilian, was closely supervised by the German Military. By 1942 the first of the test models of the A4 were ready.

The rocket was placed vertically on its launching stand, and four seconds after lift off began to tilt about one degree per second, until it reached an angle of 41 degrees. During the powered phase of the flight, the rocket was controlled by two gyroscopes which indirectly controlled the steering vanes. The alcohol and

liquid oxygen were fed into the combustion chamber by turbo pumps which were driven by steam generated by combining hydrogen peroxide and potassium permanganate.

Twenty-five tons of thrust was generated during the burning time of sixty seconds, and at the end of the propelled part of the trajectory the rocket had attained a velocity of 3800 miles per hour, or mach 6. The cut off of power was by radio signal at an altitude of 17 miles, and the rocket then coasted up to about 70 miles. When the missile re-entered the atmosphere it heated up to 1,002° F.

By the end of the war, approximately 3,300 V-2's had been fired by tactical units. A high percentage of these shots fell short of their targets, and there were also a great number of failures at takeoff. However, the fact remains that the V-2 (Vengeance-2) was the forerunner of all of today's large intercontinental ballistic missiles, and also laid the foundation for much of man's research into space. It opened a new era in terror as well as discovery.

SPECIFICATIONS

LENGTH	45 feet 11¾ inches
DIAMETER	66 inches
FIN SPAN	11 feet 9 inches
LAUNCH WEIGHT	28,373 lbs.
RANGE	190-200 miles
FUEL	T-Staff (Hydrogen Peroxide) and C-Staff (Liquid Oxygen)
WARHEAD	2,145 lbs. Amatol

ENGLISH: ASSEMBLY DRAWINGS SHOULD BE REVIEWED BEFORE PROCEEDING WITH CONSTRUCTION. A NUMBER IDENTIFIES EACH PLASTIC PART FOR YOUR CONVENIENCE. PAINT SMALL PARTS ON RUNNER BEFORE REMOVING. ALLOW PAINT TO DRY THOROUGHLY BEFORE CONTINUING ASSEMBLY OF KIT. SCRAPE CHROME OR PAINT AT AREA TO BE GLUED. WASH PLASTIC IN MILD DETERGENT SOLUTION. RINSE AND LET AIR DRY FOR BETTER PAINT AND DECAL ADHESION.

DEUTSCH: VOR DEM ZUSAMMENBAU DIE BAUANLEITUNG GUT DURCHLESEN. JEDES TEIL IST NUMMERIERT. KLEINE TEILE ANSTREICHEN BEVOR SIE VOM RAHMEN ENTFERNT WERDEN. FARBEN GUT TROCKNEN. ERST DANN MIT DER ZUSAMMENSTELLUNG FORTSETZEN. CHROM UND FARBE AN DEN KLEBEFLAECHEEN ENTFERNEN. PLASTIKTEILE IN EINER MILDEN WASCHMITTELLOESUNG REINIGEN UND AN DER LUFT TROCKNEN. DAMIT FARBE UND ABZIEHBILDER BESSER HAFTEN.

FRANCAIS: EXAMINER LES SCHEMAS D'ASSEMBLAGE AVANT DE COMMENCER LA CONSTRUCTION. UN NUMERO IDENTIFIE CHAQUE PIECE DE PLASTIQUE POUR PLUS DE FACILITE. PEINDRE LES PETITES PEICES SUR LE SUPPORT AVANT DE LES ENLEVER. LAISSER LA PEINTURE SECHER COMPLETEMENT AVANT DE CONTINUER L'ASSEMBLAGE DU KIT. GRATTER LE CHROME OU LA PEINTURE SUR LES SURFACE A COLLER. LAVER LE PLASTIQUE DANS UNE SOLUTION DE DETERGENT LEGERE, RINCER ET LAISSER SECHER A L' AIR POUR UNE MEILLEURE ADHERENCE DE LA PEINTURE ET DES DECALS.

NEDERLANDS: BESTUDEER DE MONTAGE TEKENINGEN, VOORDAT U MET BOUWEN BEGINT. VOOR UW GEMAK, IDENTIFICEERT EEN NUMMER ELK PLASTIC DEEL. VERF KLEINE DEELTJES OP KIBOOM VOORDAT U ZE VERWYDERD. LAAT VERF GRONDIG DROGEN VOORDAT U DE MONTAGE VAN HET MODEL VOORTZET. SCHRAP CHROOM OF VERF VAN HET GEDEELTE DAT GELYMD WORDT. WAS PLASTIC MET EEN ZACHTE ZEEP. SPOEL AF, EN LAAT IN LUCHT DROGEN, ZODAT VERF EN DECAL BETER PLAKKEN.

SVENSKA: HOPSATTNINGSSKISSEN BOR GRANSKAS INNAN I GANGSATTANDE AV BYGGANDET. ETT NUMMER IDENTIFIKERAS INNAN PLASTDEL FOR DIN EGEN BEKVAMLIGH ET. MALA DE SMA BITARNA DIREKT PA FARAN INNAN DE TAS BORT. LAT FARGEN TORKA GRUNDLIGT INNAN FORTSATT BYGGANDE. SKRAP AV KROMEN ELLER MALA PA DELARNA SOM SKALL KLISTRAS. TVATTA PLASTEN I MILD TVATTMEDELLOSNING, SKOJ OCH LUFTTORKA FOR BATTRE FASTANDE AV FARG OCH DEKALER.

ESPAÑOL: DIBUJOS DE ENSAMBLAJE DEBEN SER REPASADOS ANTES DE SEGUIR CON LA CONSTRUCCION. UN NUMERO IDENTIFICA CADA PARTE DEL PLASTICO PARA SU CONVENIENCIA. PINTA PARTES PEQUEÑAS DEL KIT ANTES DE QUITARLAS. DEJE SECAR BIEN LA PINTURA ANTES DE SEGUIR EL ENSAMBLAJE. RASPE EL CROMO O LA PINTURA DEL SITIO ANTES DE SER PEGADO. LAVE EL PLASTICO EN UNA SOLUCION SUAVE DETERGENTE, ENJUAGUE, Y DEJE SECAR EN EL AIRE PARA MEJOR ADHESION DE LA PINTURA Y CALCOMANIA.

ITALIANO: I DISEGNI DELL'ASSEMBLAGGIO DOVREBBERO ESSERE RICONTROLLATI PRIMA DI INIZIARE IL MONTAGGIO. OGNI PEZZO E IDENTIFICATO DA UN NUMERO PER VOSTRA MAGGIORE COMODITA'. VERNICIARE LE PARTI PICCOLE SULLA GUIDA DE SCORRIMENTO PRIMA DE TOGLIERLE. LASCIAR ASCUIGARE LA VERNICE PRIMA DI CONTINUARE IL MONTAGGIO. RASCHIAR LA PITTURA O IL CROMO DALLE PARTI CHE DE VONO ESSERE INCOLLATE. LAVARE I PEZZI DI PLASTICA CON UN DETERGENTE NON TROPPO FORTE, SCIACQUARE E LASCIAR ASCUIGARE AFFINCHÉ VERNICE E DECALCOMANIE ADERISCANO MEGLIO.



GLUE
KLEBER
COLLE
LIJM
KLISTER
PEGA
COLLA



NO GLUE REQUIRED
KEIN KLEBER NOTWENDIG
LA COLLE N'EST PAS NECESSAIRE
GEEN LIJM NODIG
INGET KLISTER BEHOVS
NO NECESITA PEGA
NON C'E BISOGNO DI COLLA



DO IT THIS MANY TIMES
ANZAHL DER ARBEITSGAENGE
LE FAIRE CE NOMBRE DE FOIS
DOE HET ZOVEEL KEER
GJOR DET SA MANGA GANGER
FATELO TUTTE QUESTA VOLTE
HAGALO ESTA CANTIDAD DE VECES



OPTIONAL
WAHLWEISE
FACULTATIF
NAAR KEUZE
VALFRI
FACOLTATIVO
OPCIONAL



SHOWN ASSEMBLED
ABBILDUNG DES ZUSAMMEN GEBAUTEN MODELLS
VU ASSEMBLE
GEMONTEERD GETOOND
VISAD IHOPSATTNING
MOSTRADO ARMADO
ILLUSTRAZIONE DEL PEZZO MONTATO



MATT DARK GREEN
MATT DUNKELGRUN
VERT FONCE MAT
MAT DONKERGROEN
MATT MORKGRON
VERDE OSCURO MATE
VERDE SCURO SMORTO

A	SILVER	SILBER	ARGENT	ZILVER	SILVER	PLATA	ARGENTO
B	GREEN	GRUEN	VERT	GROEN	GRON	VERDE	VERDE
C	BLACK	SCHWARZ	NOIR	ZWART	SVART	NEGRO	NERO
E	MATT OLIVE GREEN	MATT OLIVGRUEN	VERT OLIVE MAT	MAT OLIJFGROEN	MATT OLIVGRON	VERDE OLIVA MATE	VERDE OLIVA SMORTO
F	FLESH	HAUTFARBE	CHAIR	VLEES KLEUR	HUDFARGAD	PIEL	CARNE
G	BLUE	BLAU	BLEU	BLAUW	BLA	AZUL	BLU
H	TAN	BEIGE	BRUN	TAANKLEUR	BEIGE	MORENO	MARRONE BRUCIATO

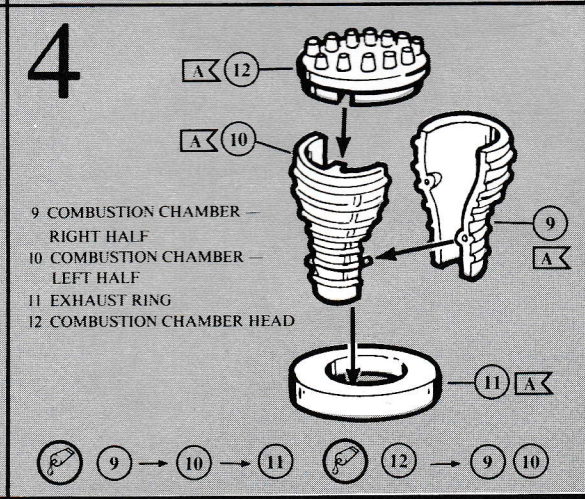
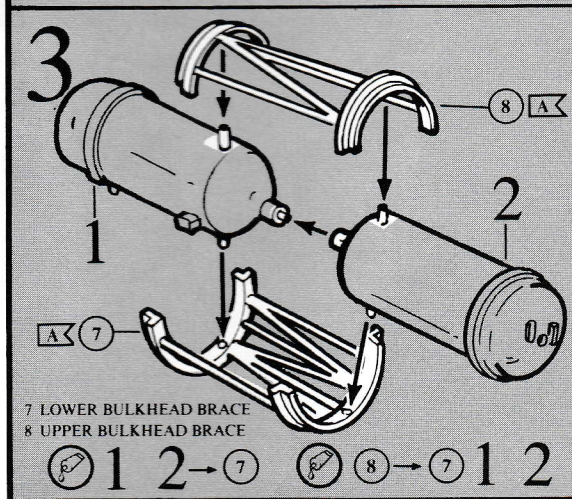
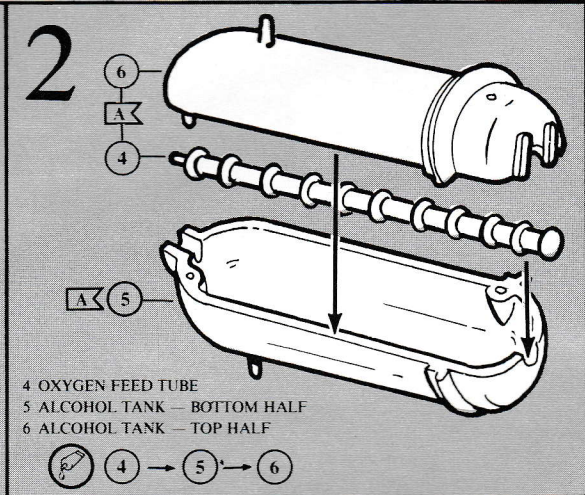
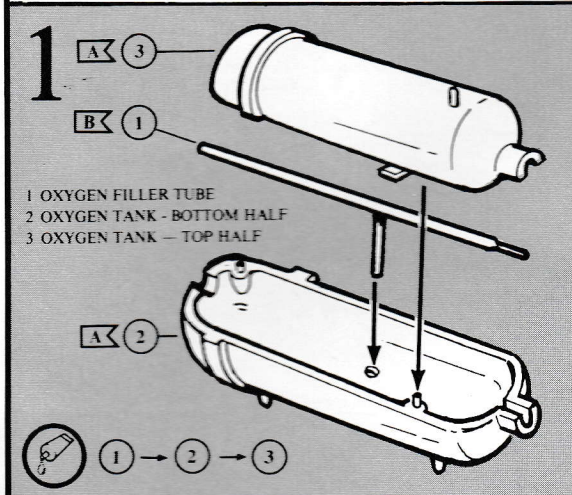
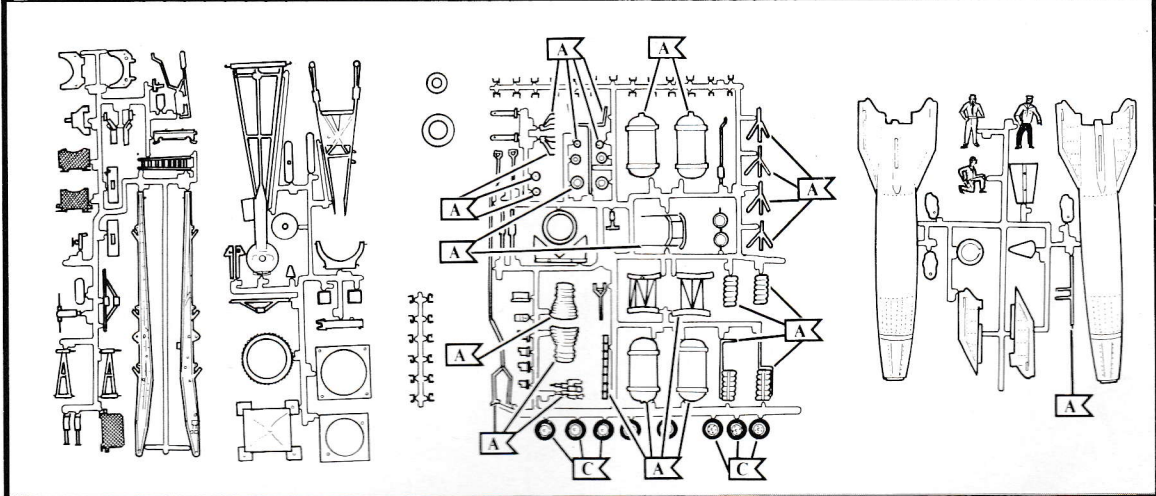

5

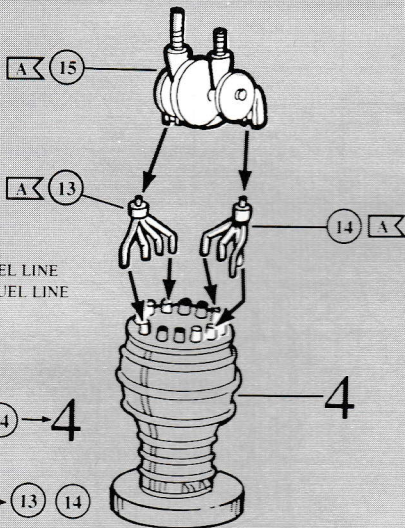

13 OXYGEN FUEL LINE
14 ALCOHOL FUEL LINE
15 FUEL PUMP

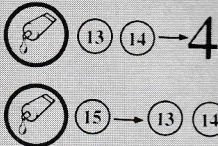

6

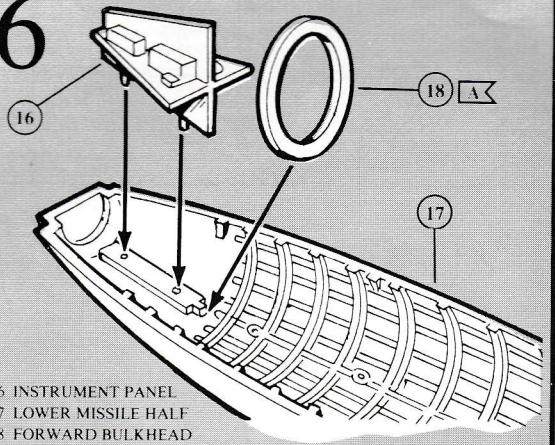

16 INSTRUMENT PANEL
17 LOWER MISSILE HALF
18 FORWARD BULKHEAD

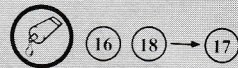

7

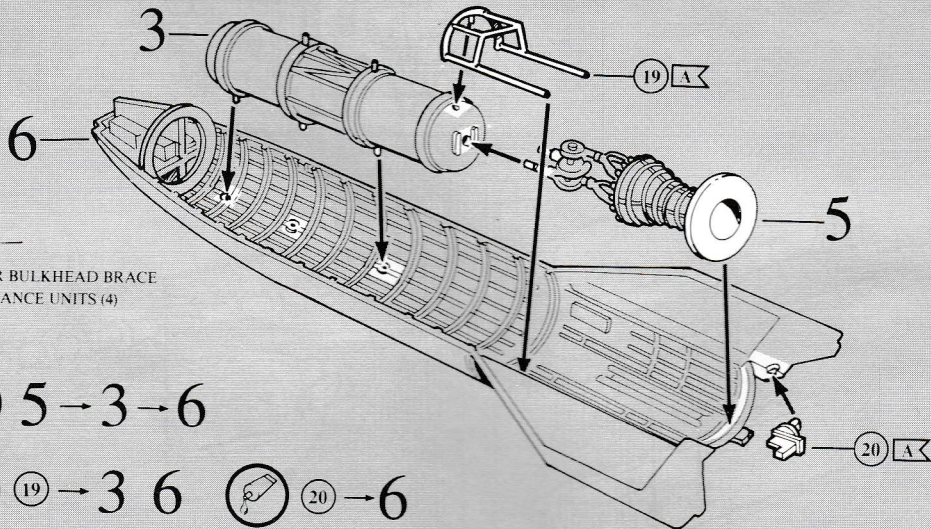

19 REAR BULKHEAD BRACE
20 GUIDANCE UNITS (4)

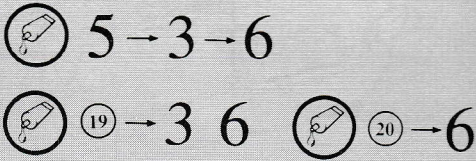

8 (2X)

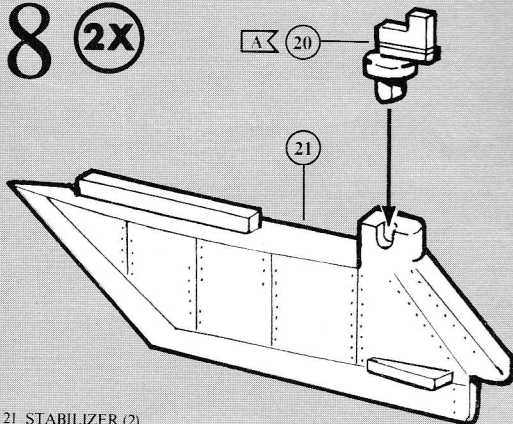

21 STABILIZER (2)

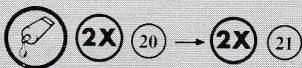

9

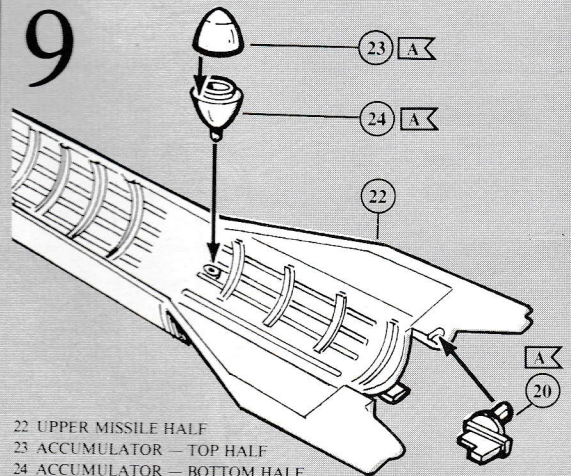

22 UPPER MISSILE HALF
23 ACCUMULATOR - TOP HALF
24 ACCUMULATOR - BOTTOM HALF

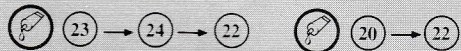

10

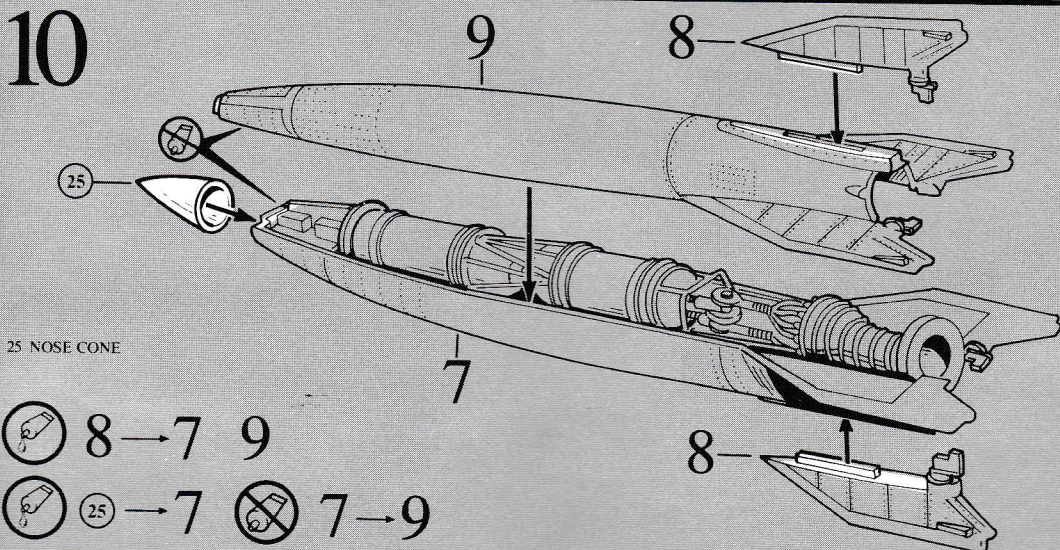

11

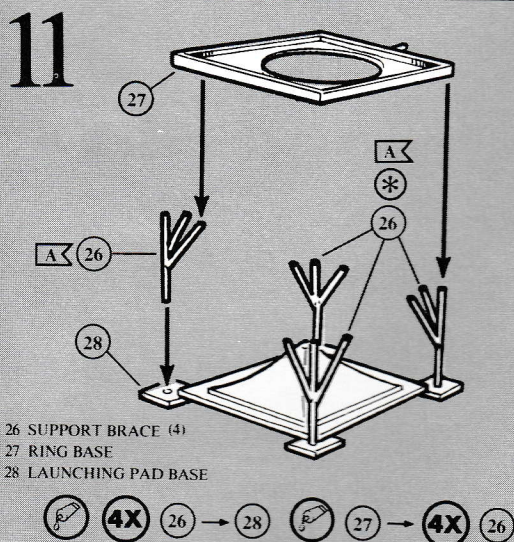

12

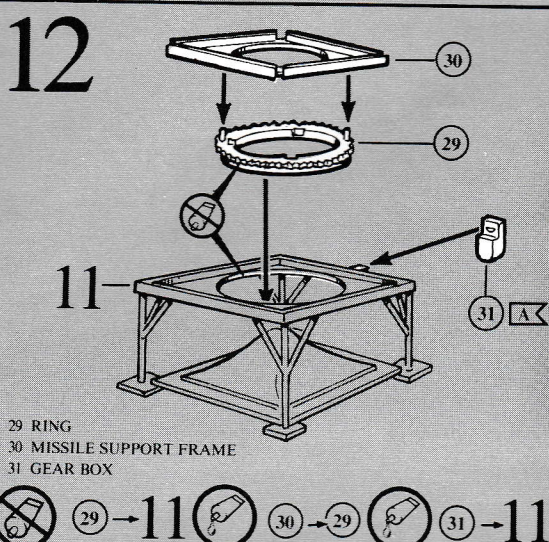

13

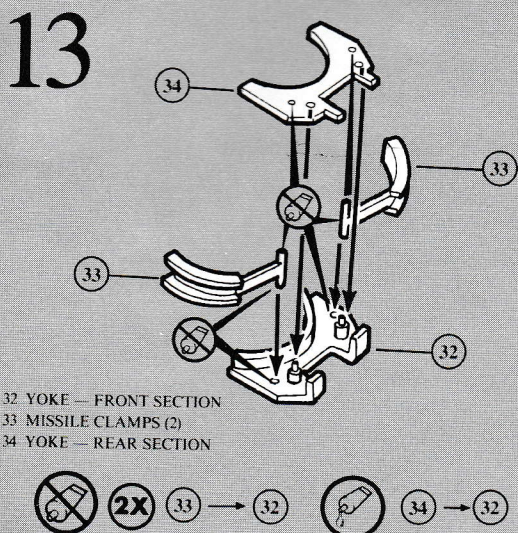

14

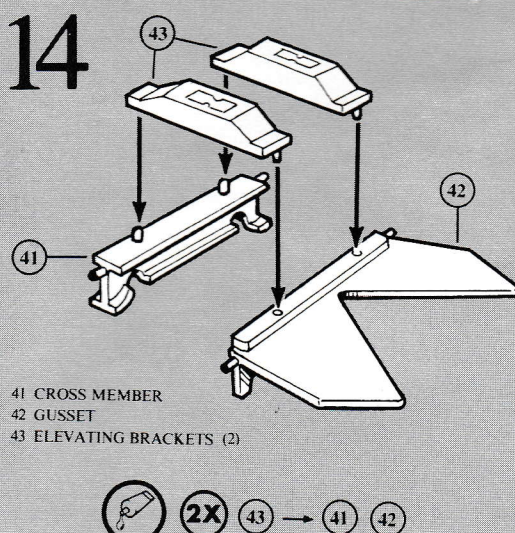

15

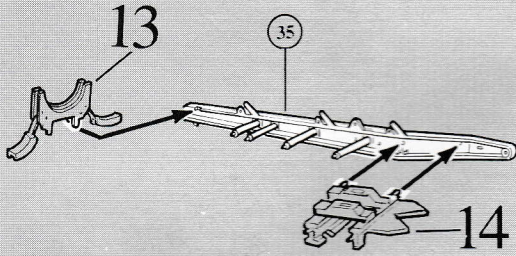

35 MISSILE SUPPORT BEAM — RIGHT HALF



16

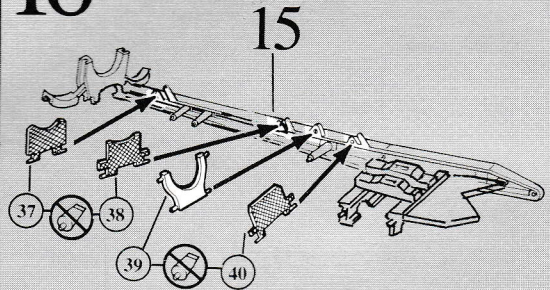

37 TOP WORK PLATFORM
38 CENTER WORK PLATFORM
39 REAR MISSILE SUPPORT YOKE
40 LOWER WORK PLATFORM

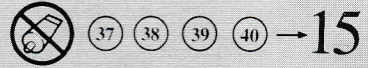

17

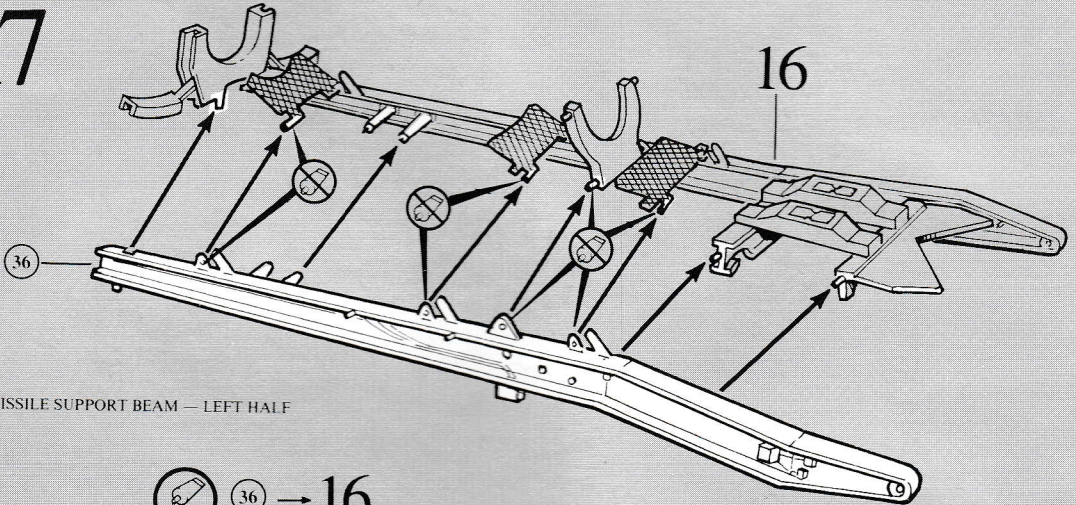

36 MISSILE SUPPORT BEAM — LEFT HALF

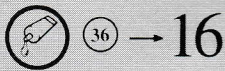

18

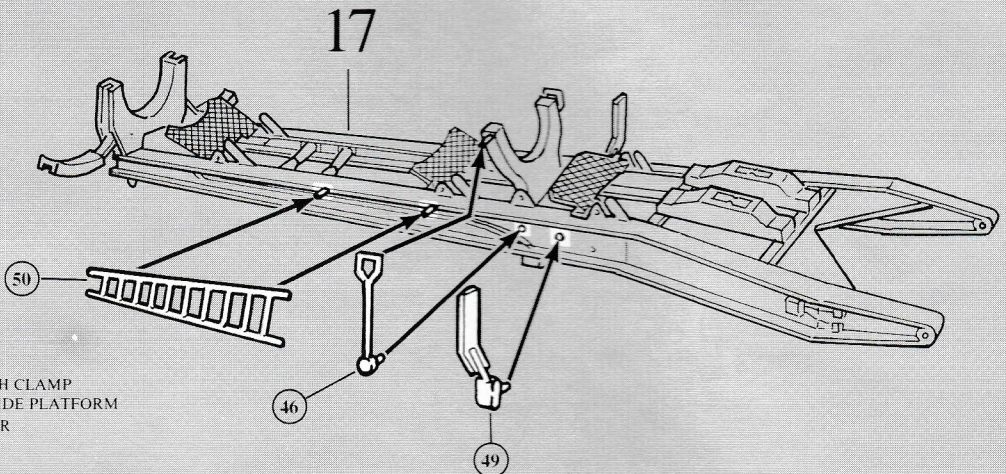

46 ATTACH CLAMP
49 LEFT SIDE PLATFORM
50 LADDER



19

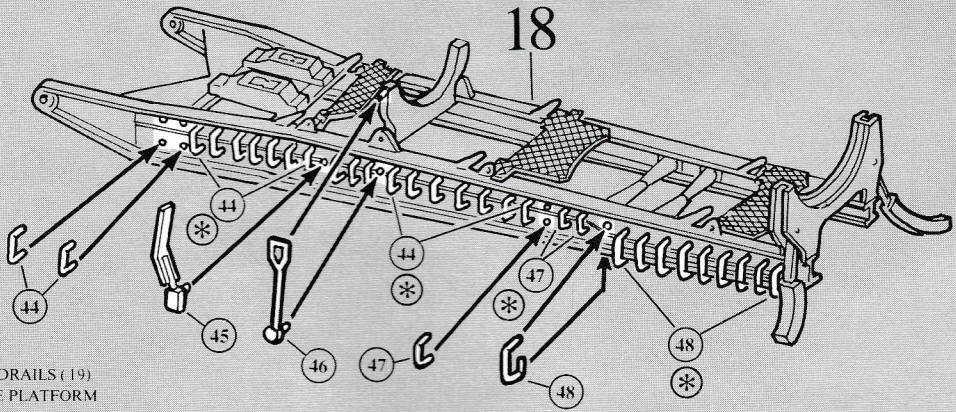

- 44 REAR HANDRAILS (19)
- 45 RIGHT SIDE PLATFORM
- 46 SMALL HANDRAIL (3)
- 47 FRONT HANDRAIL (10)

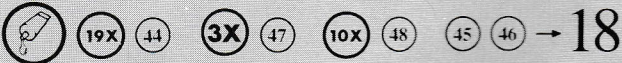

20

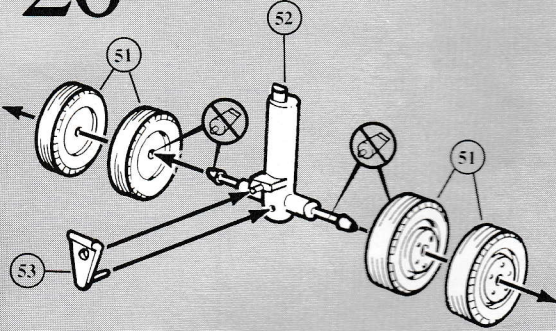

- 51 REAR TRANSPORTER WHEELS (4)
- 52 REAR AXLE FRAME
- 53 TOW LINK

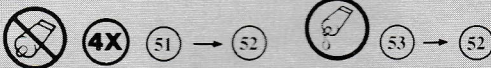

21

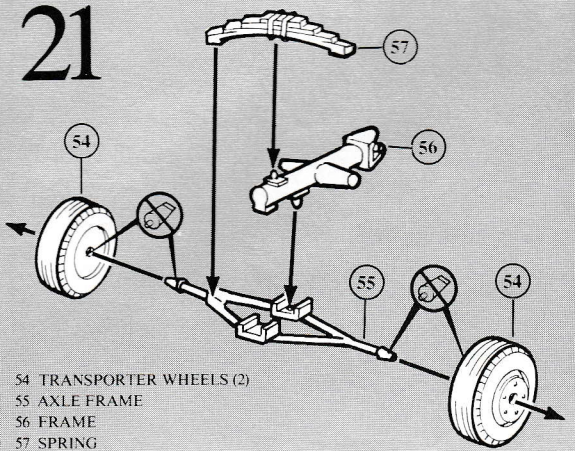

- 54 TRANSPORTER WHEELS (2)
- 55 AXLE FRAME
- 56 FRAME
- 57 SPRING



22

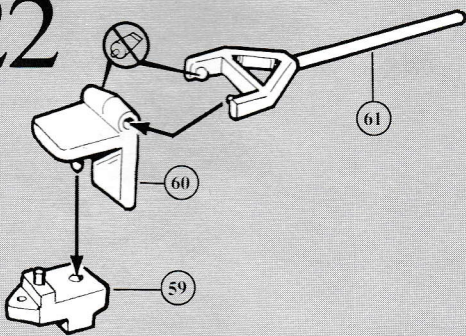

- 59 FRONT AXLE STEERING LINK
- 60 FRONT AXLE PIVOT BAR
- 61 TOW BAR



23

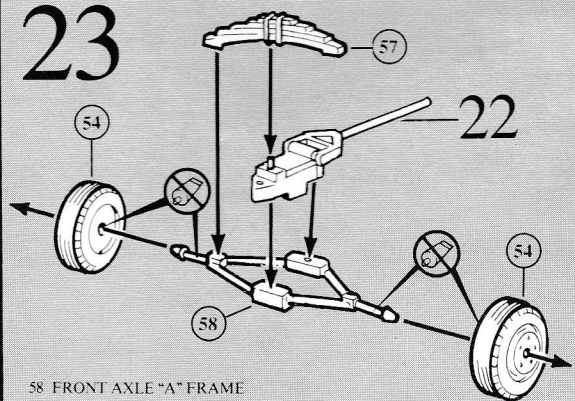

- 58 FRONT AXLE "A" FRAME



24

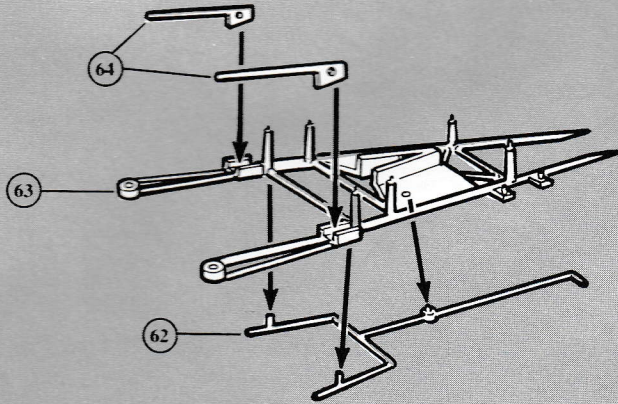

- 62 AIRLINE
- 63 TRAILER LOWER FRAME
- 64 TRAILER SIDE BRACE (2)



25

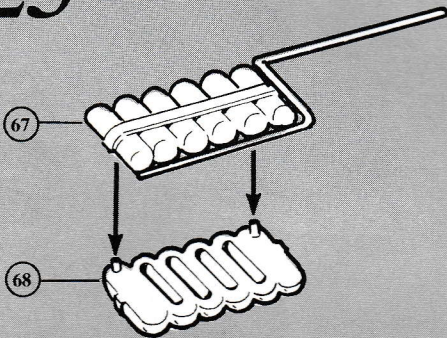

- 67 AIR BOTTLES TOP LEFT HAND
- 68 AIR BOTTLES BOTTOM LEFT HAND

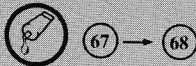

26

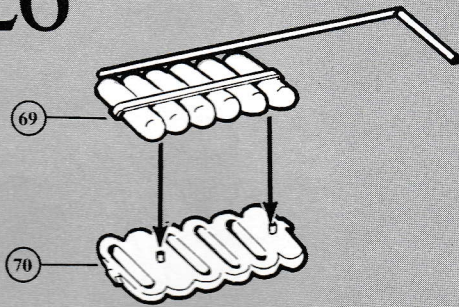

- 69 AIR BOTTLES TOP RIGHT HAND
- 70 AIR BOTTLES BOTTOM RIGHT HAND

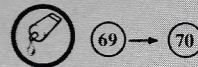

27

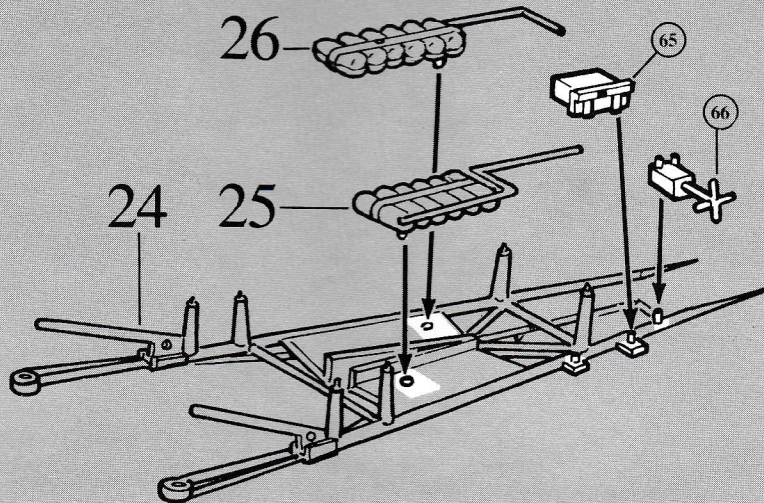

- 65 TOOL BOX
- 66 CONTROL VALVE AND HANDLE

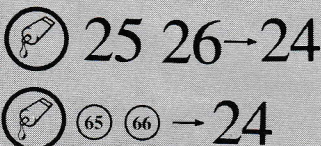

28

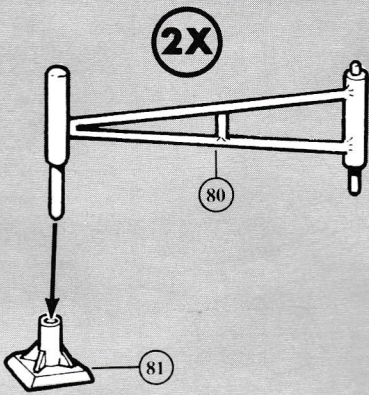

80 SWAY BRACE (2)
81 GROUND PAD (2)

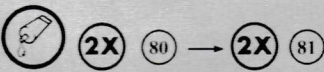

29

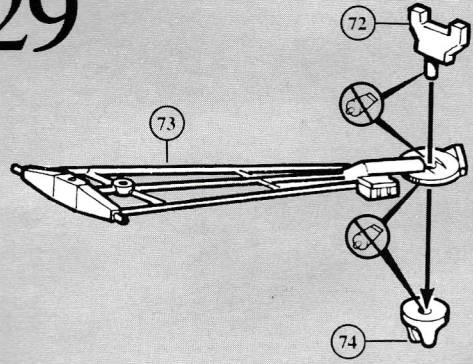

72 FRONT AXLE PIVOT PIN
73 TRAILER UPPER HALF
74 FIFTH WHEEL



30

71 AUXILIARY BOTTLES AND AIR LINE
79 HYDRAULIC STRUT BRACE

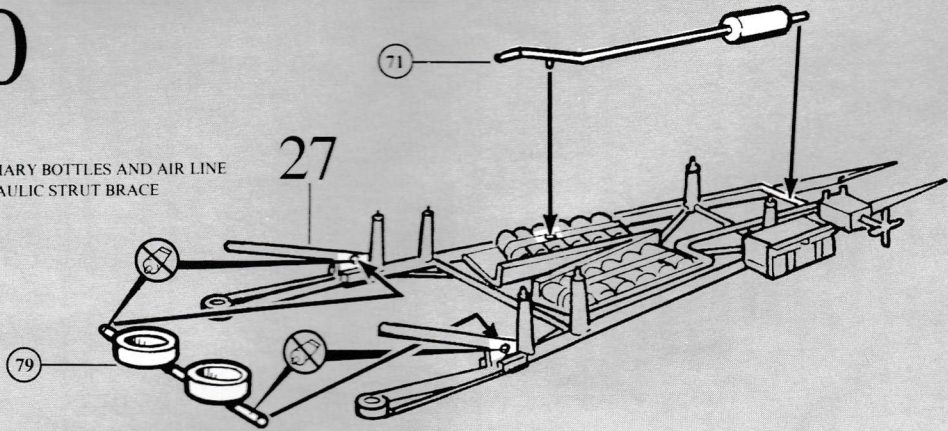

31

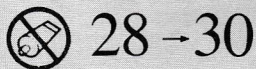
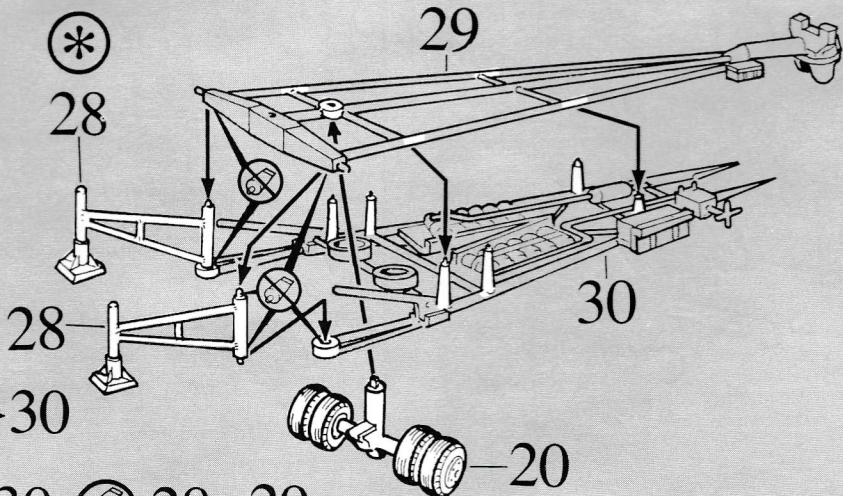

32

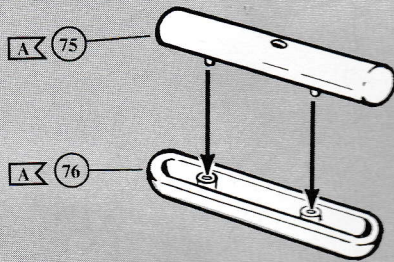

75 SUPPLY TANK — UPPER HALF
76 SUPPLY TANK — LOWER HALF

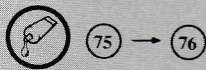

33

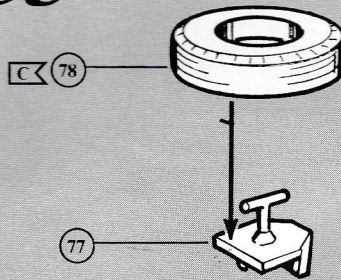

77 SPARE TIRE SUPPORT
78 SPARE TIRE

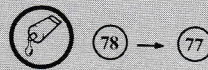

34

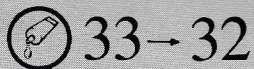
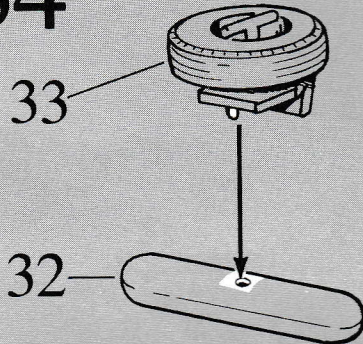

35

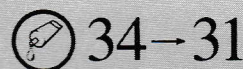
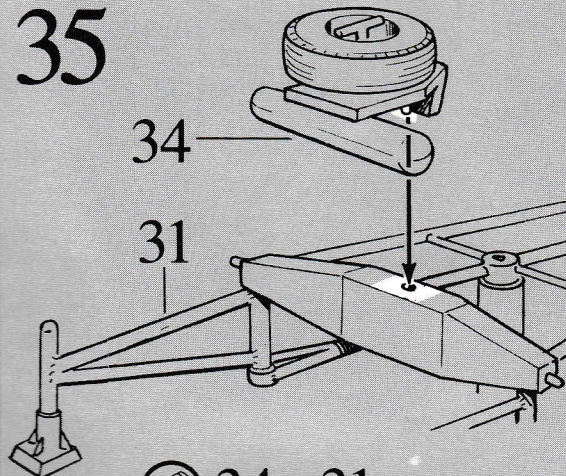

36

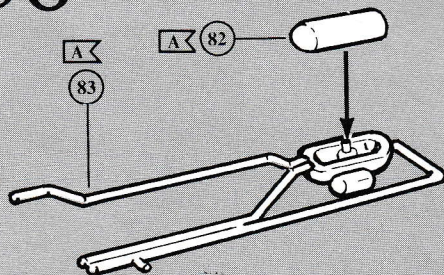

82 TOWER CONTROL TANK — BOTTOM
83 TOWER CONTROL TANK — TOP

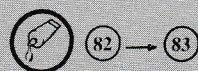

37

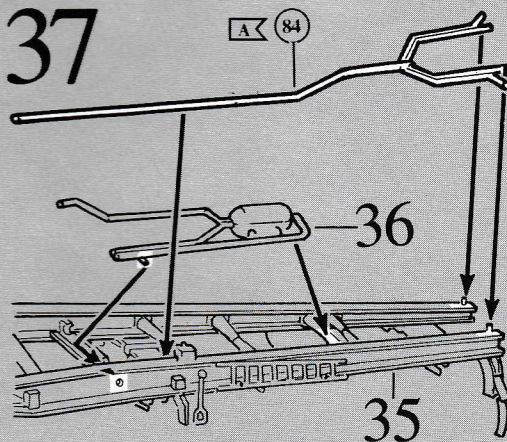

84 TOWER CONTROL LINE

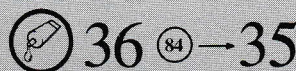

38

2X

- 85 ELEVATING STRUT 1ST STAGE
- 86 ELEVATING STRUT 2ND STAGE
- 87 ELEVATING STRUT 3RD STAGE
- 88 ELEVATING STRUT 4TH STAGE

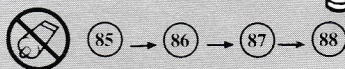
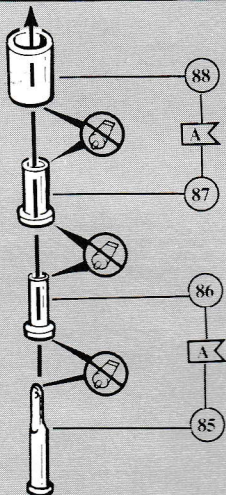

39

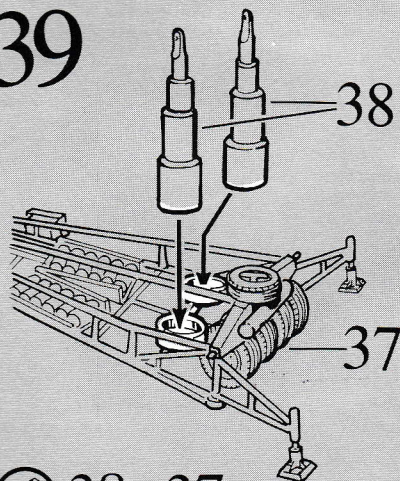

40

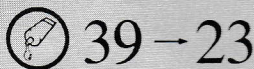
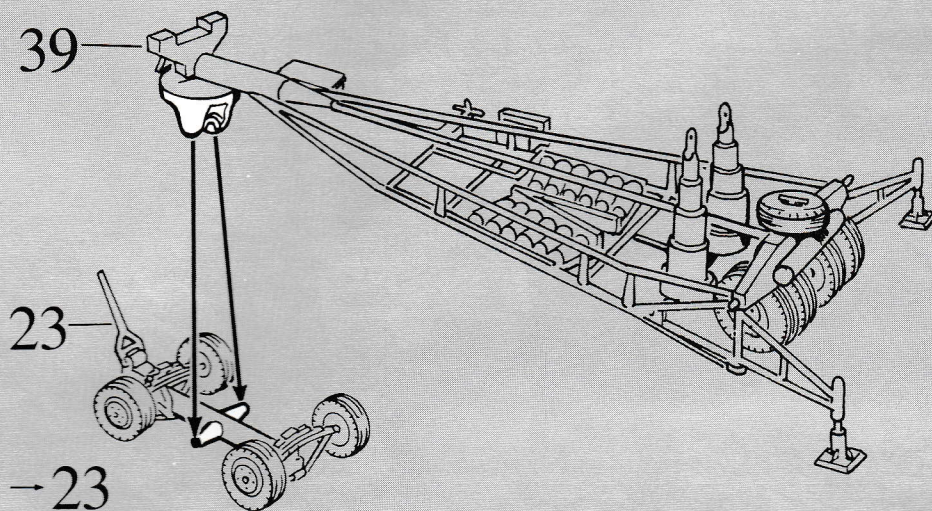

41

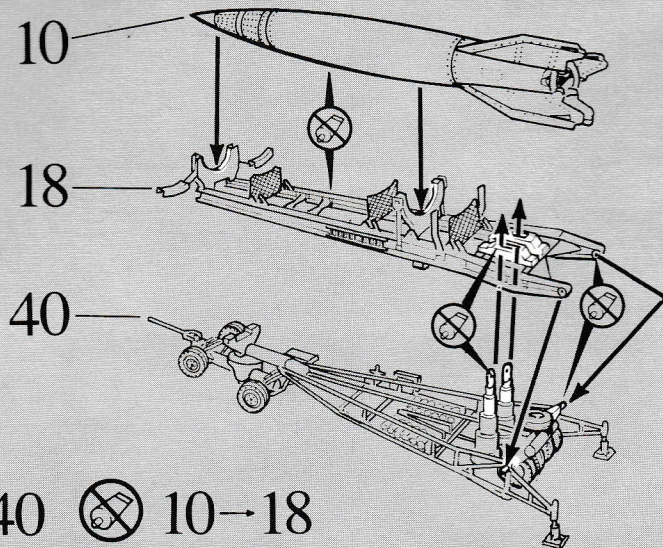

42

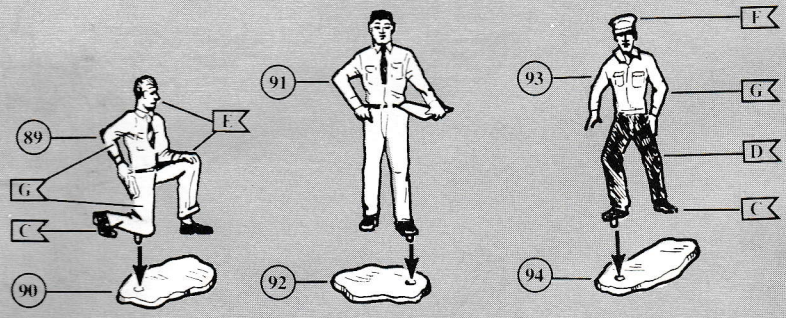

- 89 KNEELING FIGURE
- 90 BASE
- 91 STANDING FIGURE WITH BOARD
- 92 BASE
- 93 STANDING FIGURE
- 94 BASE

43

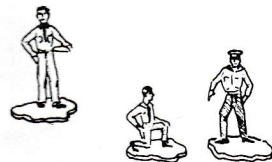
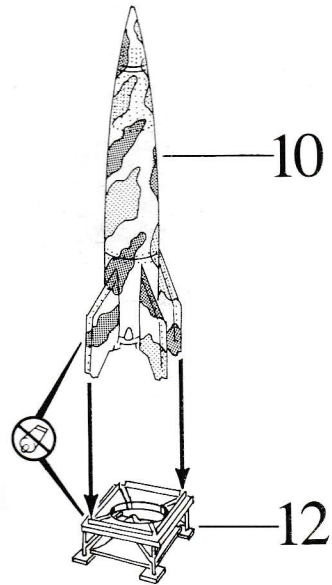
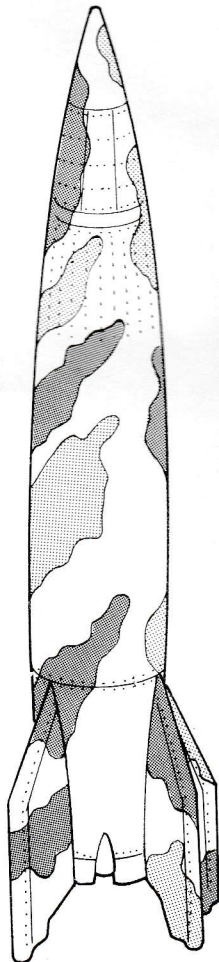
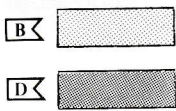

~~10~~ → 12