



FOWLER AVIATION

SHEET NO. 14



**1/144 SCALE
RECOMMENDED
KIT
AIRFIX
727**

**P.O. BOX 148
SUNNYMEAD
CA. 92388**

WE WISH TO THANK NATIONAL
AIRLINES, AL LLOYD, R.R.
LEADER AND LARRY POTOSKI
FOR THEIR ASSISTANCE.

ROSTER

ANN	N4614	727-35
LYNN	N4620	727-35
MARY	N4622	727-35
ELIZABETH	N4730	727-235
VIRGINIA	N4732	727-235
NANCY	N4738	727-235

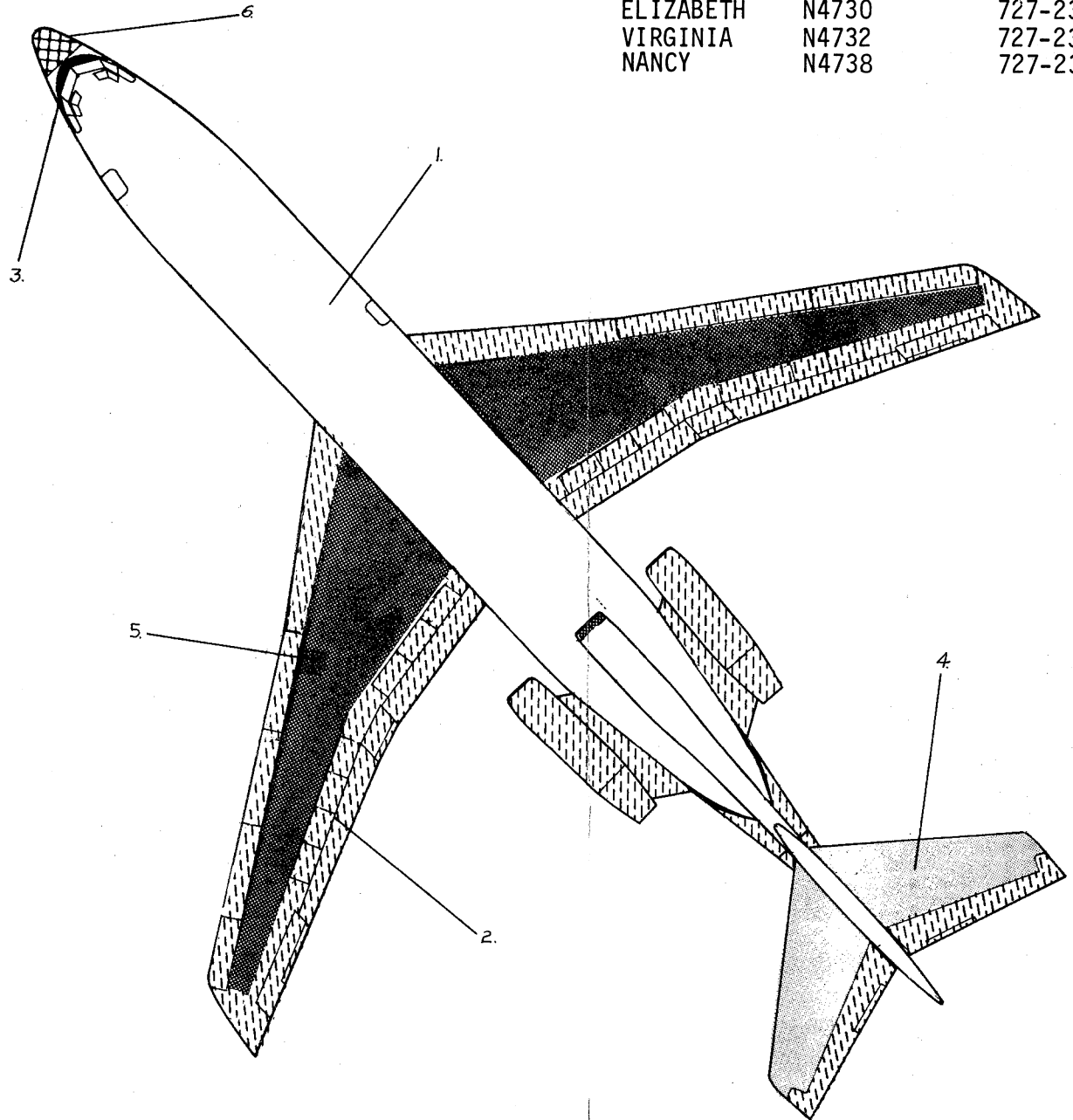

TOP VIEW

