

eduard

ProfiPACK

1/48th scale kit

8070

NIEUPOORT Ni 11



The Nieuport 11 was designed by the company design team led by Gustav Delage in late 1915 as a small single seat derivative of the larger Nieuport 10. The aircraft was designed with the top wing larger than lower one, permitting excellent maneuverability as well as sufficient strength. The powerplant was the 80 hp Le Rhone 9C rotary engine. Because an adequate synchronisation system wasn't available at the time, the Lewis machine gun was fixed on a special mounting on the top of the upper wing, which allowed forward firing above the propeller arc. Altogether, these ideas produced a very modern fighter aircraft, which was able to oppose the still dangerous German Fokker E.III monoplanes. The Nieuport 11 saw operational service for the first time on January 5, 1916. When the battle of Verdun began on February 21, 1916, nine Nieuport 11 escadrilles were available for that front to achieve air superiority. Nieuport 11s became the main weapon of the French fighter units during early 1916, when most of the famous French fighter aces used these small, but effective fighters. Nieuport 11s were replaced in frontline service in late 1916 by the Nieuport 17, but served on as advanced fighter trainers. The Nieuports 11 was extensively employed by other allied air forces. 543 Ni 11 aircraft were built under licence in Italy by Macchi-Nieuport and OEF companies. About 200 of them were built in Russia, where many of them were employed as late as the early 20's. Ni 11's were also used by the R.F.C., The Belgian AF, as well as in Rumania, Serbia, the Ukraine, Siam and the Netherlands. Escadrille N 124, famous as Escadrille Lafayette, consisted of American volunteer pilots, was formed in April 1916, with the Ni 11.





Technical data (with 80 hp Le Rhone 9C rotary engine): span 7.52 m, length 5.50 m, wing area 13.3 sq.m, empty weight 320 kg, loaded weight 480 kg, max.speed 162 km/h at 2000 m, climb to 2000 m in 8.50 minutes, range 250 km, endurance 2.5 hours.



Nieuport 11 byl zkonstruován koncem roku 1915 konstrukčním týmem společnosti Nieuport vedeným Gustavem Delagem jako malý, jednosedadlový derivát většího Nieuportu 10. Letoun byl konstruován jako jedenapůlplášník, horní křídlo mělo hloubku než spodní. Tato konfigurace slibovala dosáhnout vynikající obratnosti při dostatečné odolnosti konstrukce draku letadla. Motor byl rotační Le Rhone 9C o výkonu 80 k. Proto nebylo k dispozici synchronizační zařízení, byl stroj vyzbrojen pevným kulometem Lewis, upevněným na konstrukci nad horním křídlem a střelícím nad okružem vrtule. Tyto konstrukční prvky dávaly dohromady velmi moderní stíhací letadlo, schopné úspěšně čelit dosud nebezpečným německým Fokkerům E.III. První Ni 11 se dostaly na frontu 5.1.1916, a kdy 21.2.1916 začala bitva o Verdun, bylo jí k dispozici devět eskader Nieuportů 11, které mohly být nasazeny k vybojování vzdušné převahy nad tímto bojištěm. Během jara 1916 se Nieuporty 11 staly hlavní výzbrojí francouzských stíhacích jednotek, kde je používala většina slavných stíhacích es té doby. Ve druhé polovině roku 1916 byly Ni 11 v první linii postupně nahrazeny modernějšími Nieuporty 17, dále se však používaly u cvičných jednotek. Nieuporty 11 byly samozřejmě také ve výzbroji ostatních spojeneckých letectev. 543 Ni 11 bylo postaveno v licenci v Itálii. Kolem 200 strojů bylo licenčně vyrobeno v Rusku, kde byly některé používány ještě začátkem dvacátých let. Byly také ve výzbroji britské R.F.C. a Belgického letectva. Létaly také v Rumunsku, Srbsku, na Ukrajině, v Siamu a v Holandsku. Mimo jiné je používala i Escadrille N 124, známá jako Escadrille La Fayette, zformovaná z amerických dobrovolníků.

Technická data (s motorem Le Rhone 9C 80 k): rozpětí 7,52 m, délka 5,50 m, plocha křídla 13,3 m², prázdná hmotnost 320 kg, startovní hmotnost 480 kg, max.rychlost 162 km/h ve 2000 m, výstup do 2000 m za 8.50 minut, dolet 250 km, vytrvalost 2.5 hod..

ATTENTION * UPOZORNĚNÍ * ACHTUNG * ATTENTION * 注意

-  Carefully read instruction sheet before assembling. When you use glue or paint, do not use near open flame and use in well ventilated room. Keep out of reach of small children. Children must not be allowed to suck any part, or pull vinyl bag over the head.
-  Před započítím stavby si pečlivě prostudujte stavební návod. Při používání barev a lepidel pracujte v dobře větrané místnosti. Lepidla ani barvy nepoužívejte v blízkosti otevřeného ohně. Model není určen malým dětem, mohlo by dojít k požití drobných dílů.
-  lire soigneusement la fiche d'instructions avant d'assembler. Ne pas utiliser de colle ou de peinture à proximité d'une flamme nue, et aérer la pièce de temps en temps. Garder hors de portée des enfants en bas âge. Ne pas laisser les enfants mettre en bouche ou sucer les pièces, ou passer un sachet vinyl sur la tête.
-  Von dem Zusammensetzen die Bauanleitung gut durchlesen. Kleber und Farbe nicht nahe von offenem Feuer verwenden und das Fenster von Zeit zu Zeit Belüftung öffnen. Bausatz von kleinen Kindern fernhalten. Verhüten Sie, daß Kinder irgendwelche Bauteile in den Mund nehmen oder Plastiktüten über den Kopf ziehen.
-  組み立てる前に必ず説明書をお読み下さい。接着剤や塗料をご使用の際は、窓を開けて十分な換気をおこない、火のそばでは使用しないで下さい。小さな子供の手の届かない所に必ず保管してください。部品や破片を嚙んだり、なめたり、飲んだりすると大変危険です。又、部品を取り出した後のビニール袋は、小さな子供が頭から被ったりすると窒息する恐れがありますので、破り捨てて下さい。

INSTRUKTION SIGNS*INSTR. SYMBOLY*INSTRUKTION SINNBILDEN*SYMBLES* 記号の説明

- 
OPTIONAL
FACULTATIF
NACH BELIEBEN
VOLBA
選択する
- 
BEND
PLIER SIL VOUS PLAIT
BITTE BIEGEN
OHNOUT
折る
- 
OPEN HOLE
FAIRE UN TROU
OFFNEN
VYVRTAT OTVOR
穴を開ける
- 
SYMETRICAL ASSEMBLY
MONTAGE SYMÉTRIQUE
SYMMETRISCHE AUFBAU
SYMETRICKÁ MONTÁ
左右均等に組み立てる
- 
A NOTH
L INCISION
DER EINSCHNITT
ZÄREZ
切る
- 
REMOVE
RETIRER
ENTFERNEN
ODRÍZNOUT
移す
- 
APPLY EXPRESS MASK
AND PAINT BEFORE
GLUING
POU IT EXPRESS MASK

COLOURS * BARVY * FARBEN * PEINTURE * 色

	TAMIYA	HUMBROL	REVELL	TESTORS	GUNZE
1 ALUMINIUM / ALUMINIUM / ALUMINIUM / HLINÍK	XF 16	56	99	1781	H 8
2 MAHAGONYI / MAHAGONI / ACAJOU / MAHAGON	XF 9	26	85	1736	H 47
3 SAND / SANDBAUN / SABLE / DŘEVO	XF 59	63	88	84	H 37
4 BLACK / SCHWARZ / NOIR / ČERNÁ	XF 1	33	8	1728	H 12
5 GUN METAL / STAHLBLAU / GRIS METAL / DÉLOVINA	X 56	53	91	1795	H 28
6 FLESH / FLEISCHFARBE / CHAIR / TĚLOVÁ	XF 15	61	35	1516	H 44
7 LEATHER / LEDER / CUIR / KŮ E	X 9	62	81	1736	H 7
8 LIGHT BLUE / HELLBLAU / BLEU MER / SVĚTLÉ MODRÁ	XF 23	HG 5	57	1741	H 67
9 GOLD / GOLD / OR / ZLATÁ	X 12	MC 16	94	1744	H 9
10 CLEAR DOPED LINEN / LINNEN / TOILE / PLÁTNO	XF 55	94	314	1702+1768	H 313
11 GRAY / GRAU / GRIS / ŠEDÁ	X 14	147	70	1732	H 57
12 BROWN / BRAUN / BRUN / HNĚDÁ	XF 9	26	85	1736	H 47
13 GREEN / GRÜN / VERT / ZELENÁ	$\frac{8}{1}$ XF 58 + X 3	88	360	1716	H 319
14 BLUE / BLAU / BLEU / MODRÁ	XF 8	25	56	2715	H 25
15 RED / ROT / ROUGE / ČERVENÁ	XF 7	60	330	1550	H23
16 WHITE / WEIß / BLANC / BILÁ	XF 2	34	5	1596	H 11
17 KHAKI / KHAKI / KAKI / KHAKI	XF 62	66	66	1711	H78

PARTS * DÍLY * TEILE * PIÈCES * 部品

<A> PP - PLASTIC PARTS

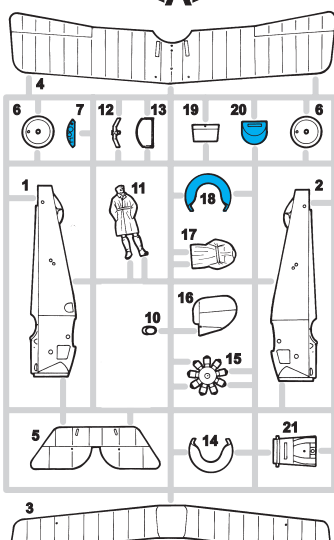

PP - CLEAR PARTS

1 

**PE - PHOTO ETCHED
DETAIL PARTS**



**eduard
Express Mask**

FILM



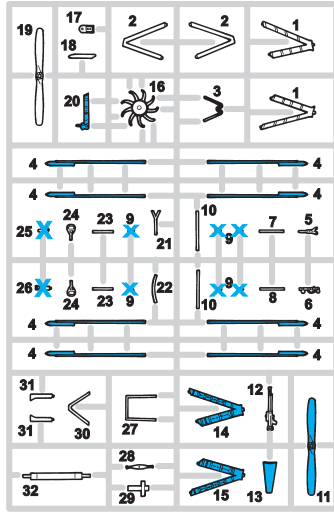

Parts not for use.
Tyto díly nepoužívejte při stavbě.
Teile werden nicht verwendet.
Pièces à ne pas utiliser.
使用しない部品

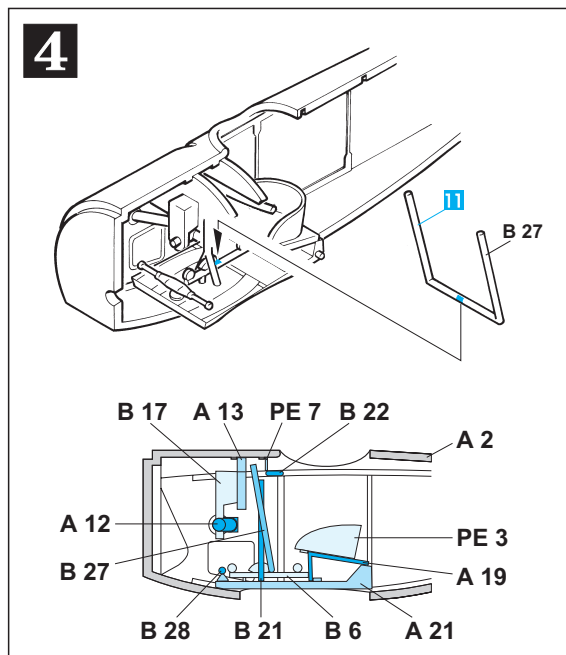
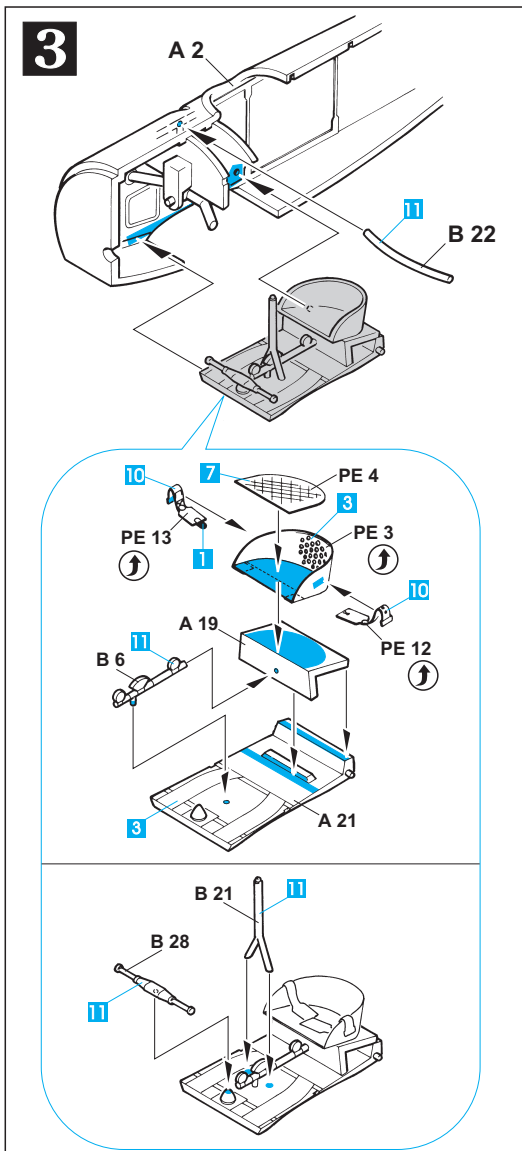
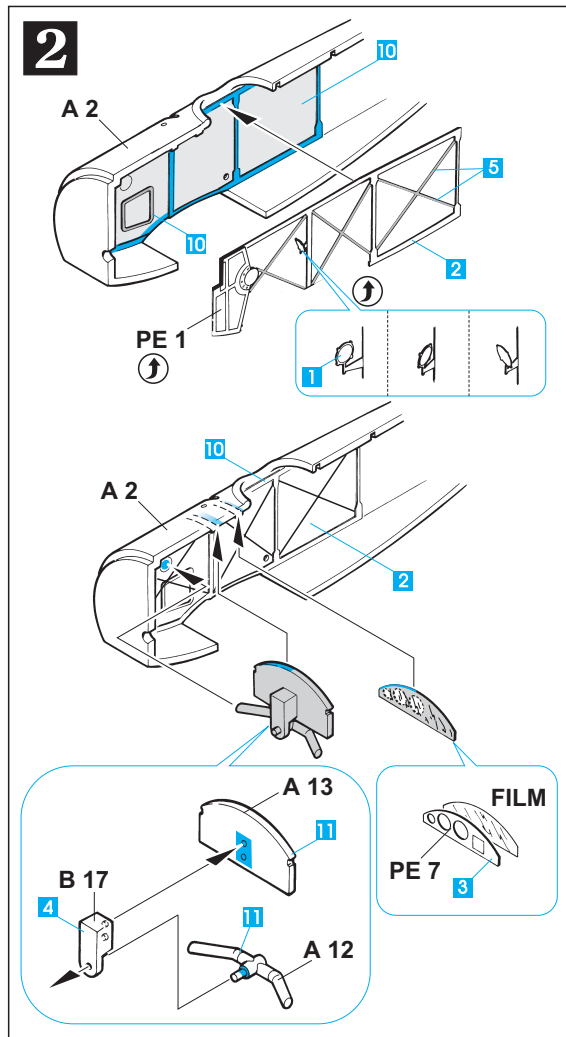
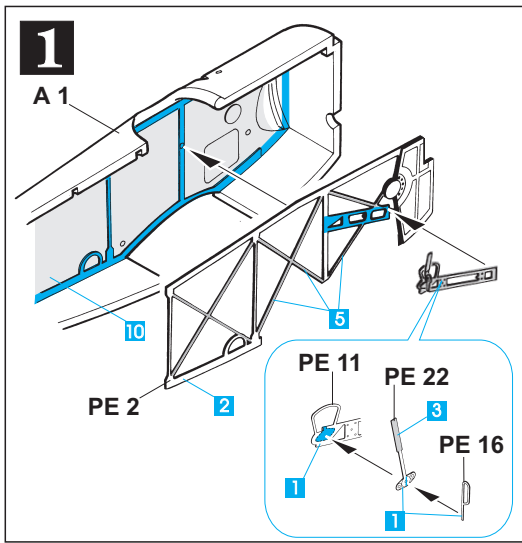

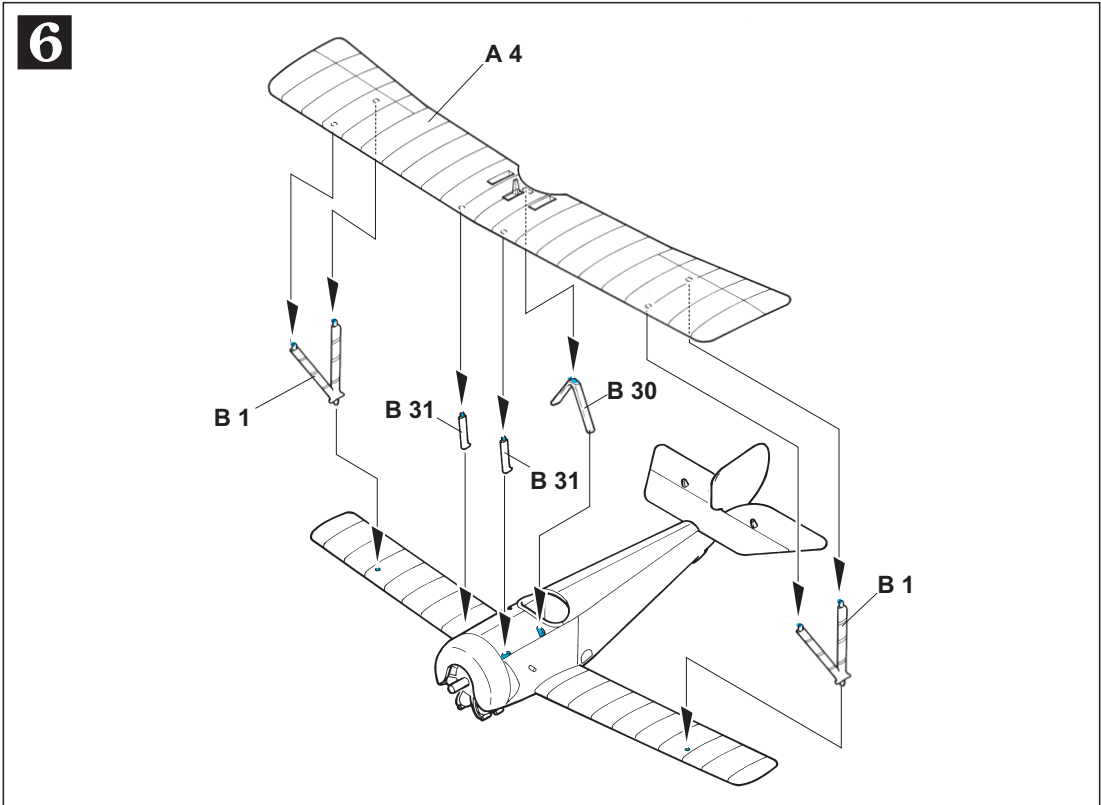
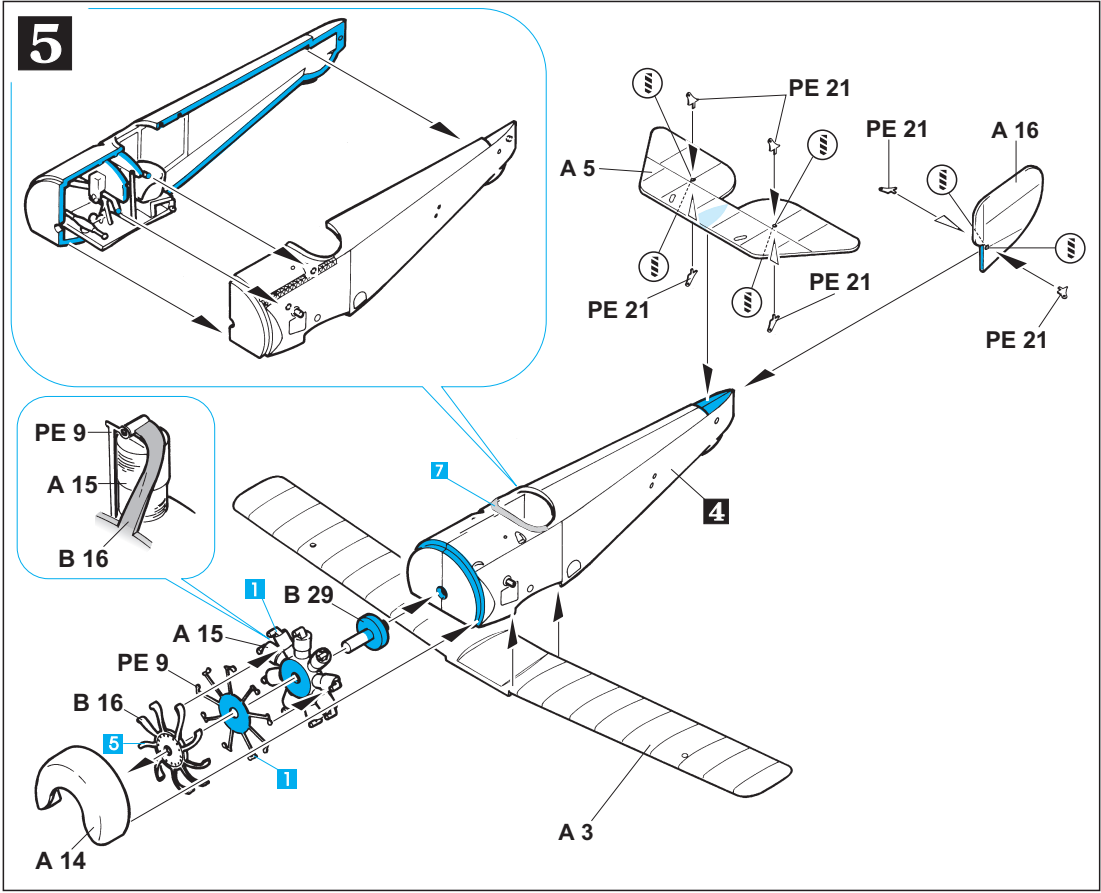

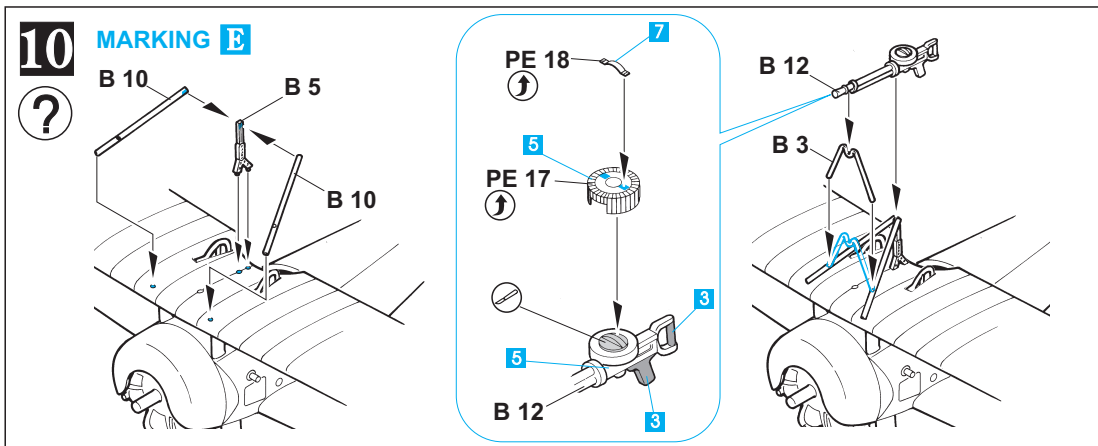
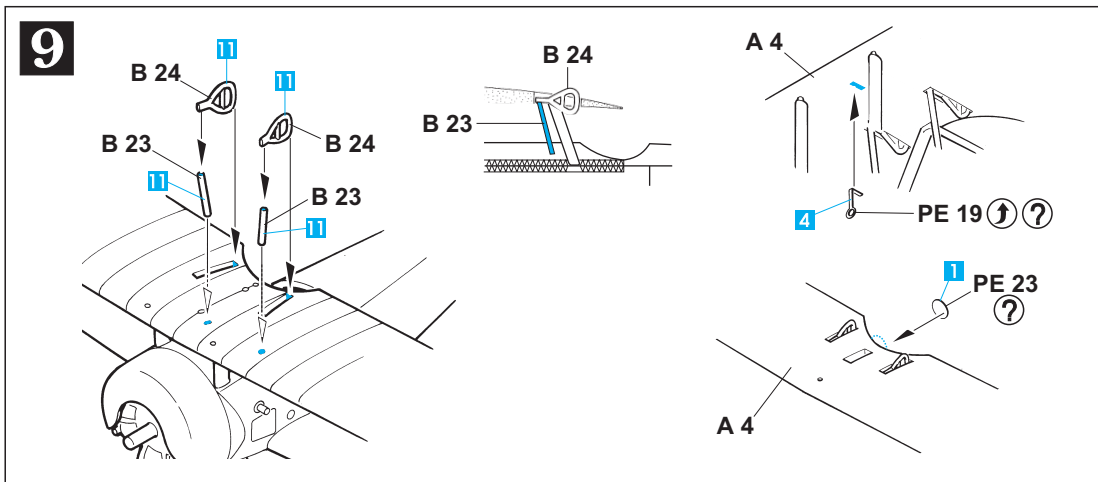
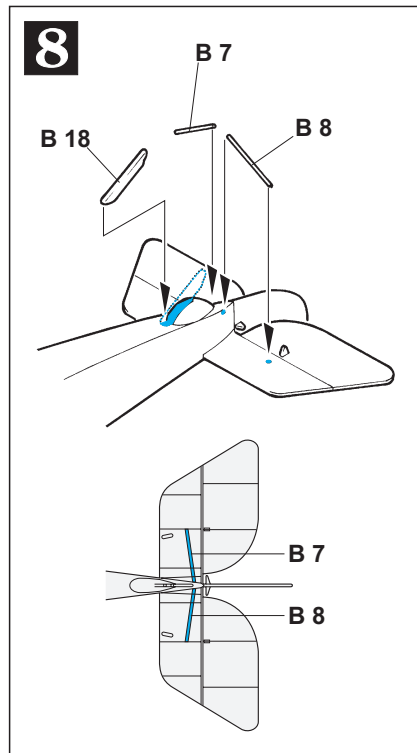
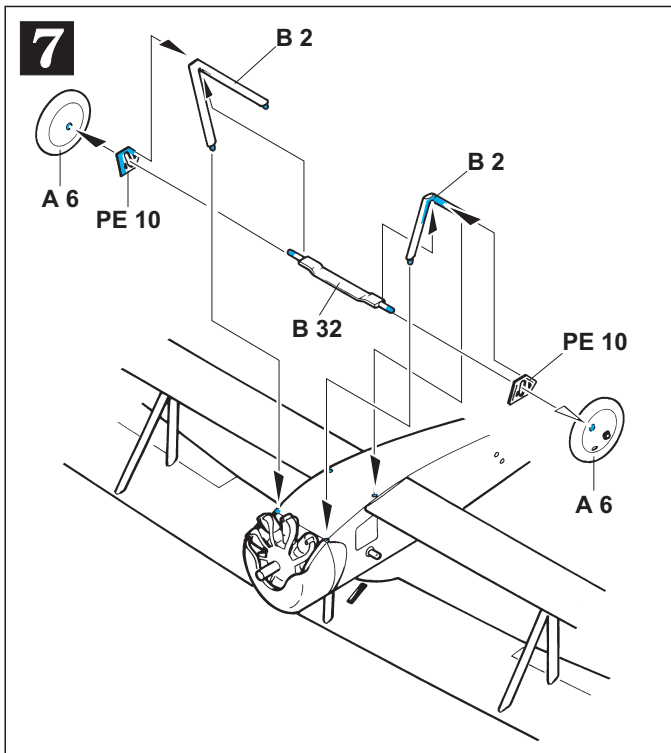

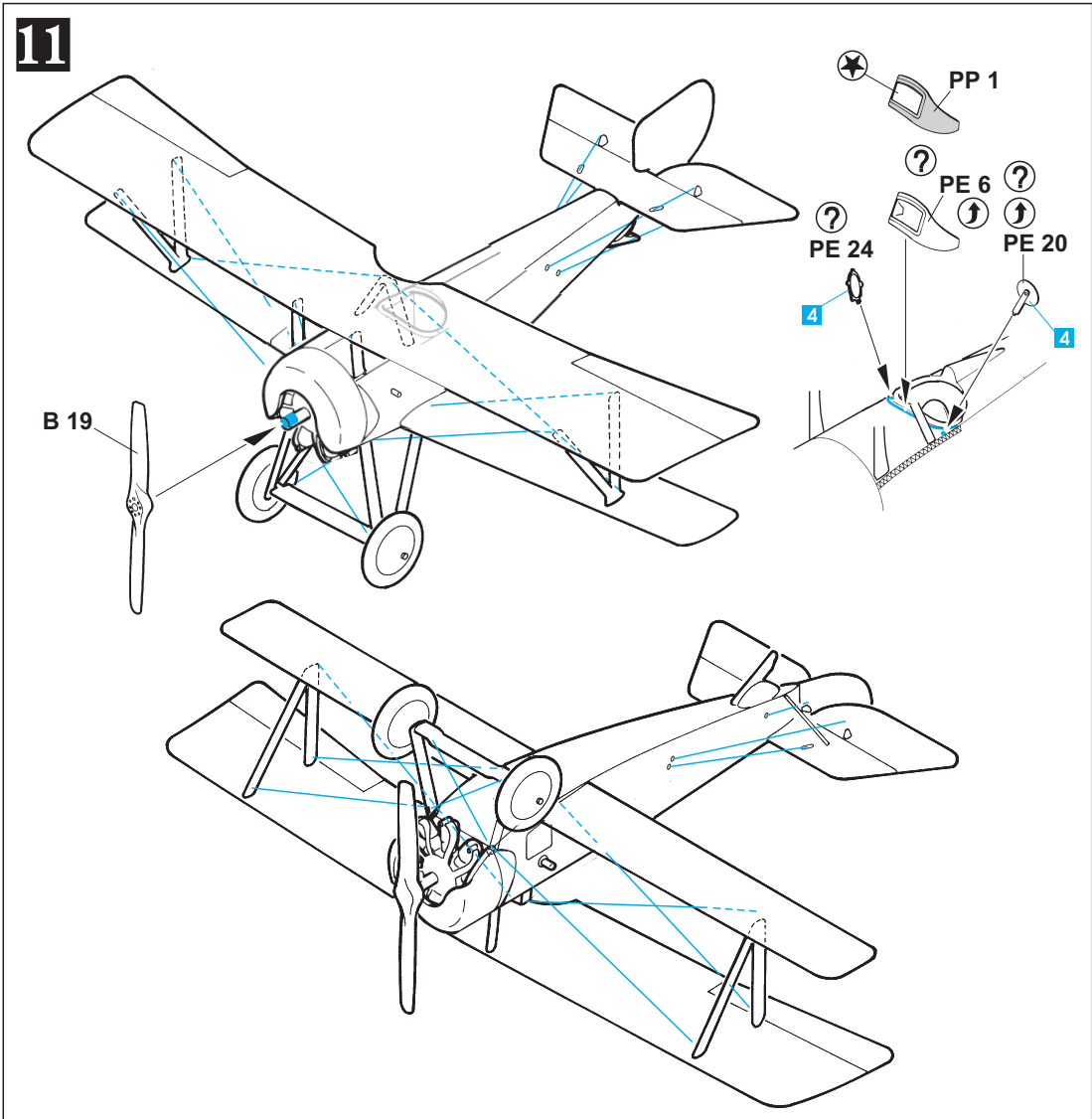
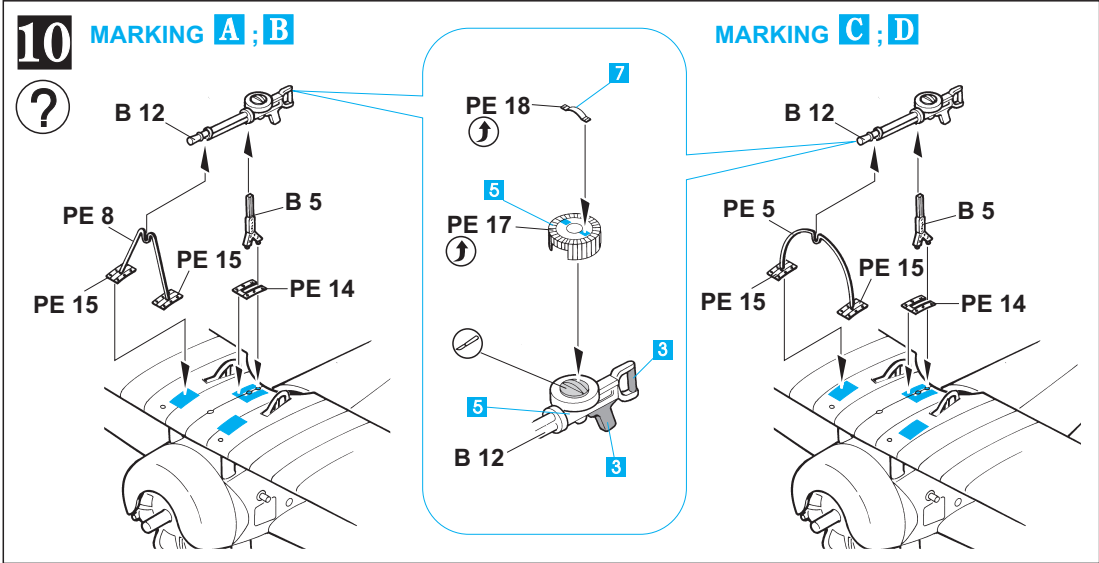

eduard
Express Mask

8070

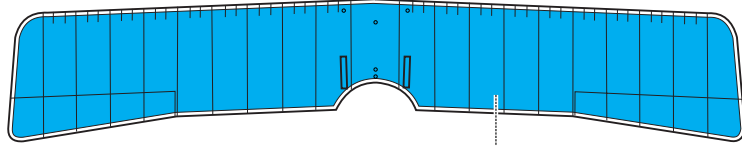
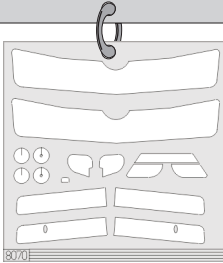

A 4 LIQUID MASK

2 pcs. A 6



2 pcs. A 6

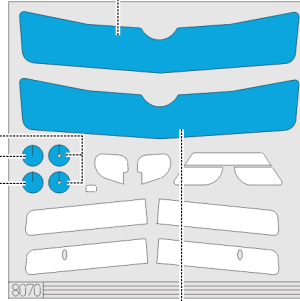

A 4

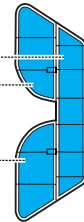
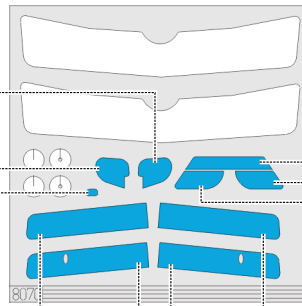
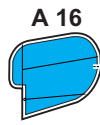
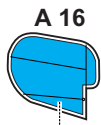
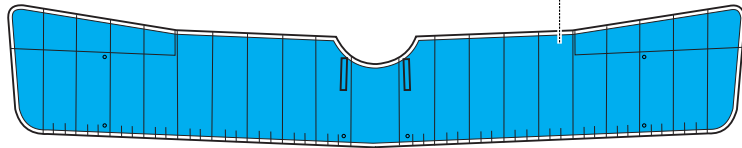

A 5

A 3

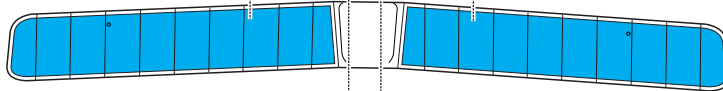

A 3

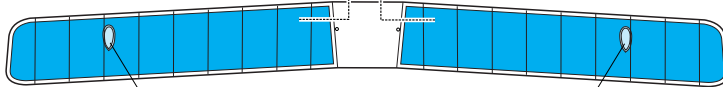

LIQUID MASK

LIQUID MASK

FOR EXACT UNIFORM PAINTING SEE YOUR REFERENCES

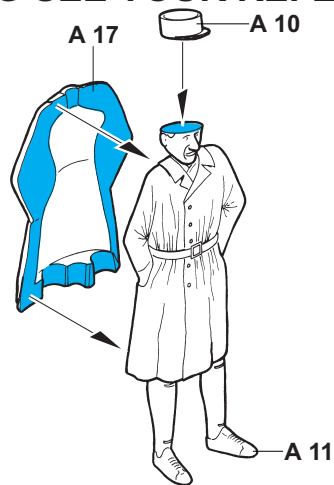
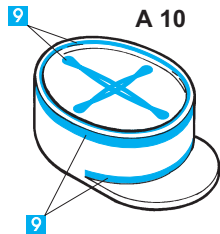

* OZNAČENÍ A ZBARVENÍ *
 MARKIERUNGEN UND BEMALUNG

* MARKING & PAINTING *
 DECORATION ET PEINTURE

A Sgt. Lawrence Rumsey, Escadrille américaine N124, September 1916

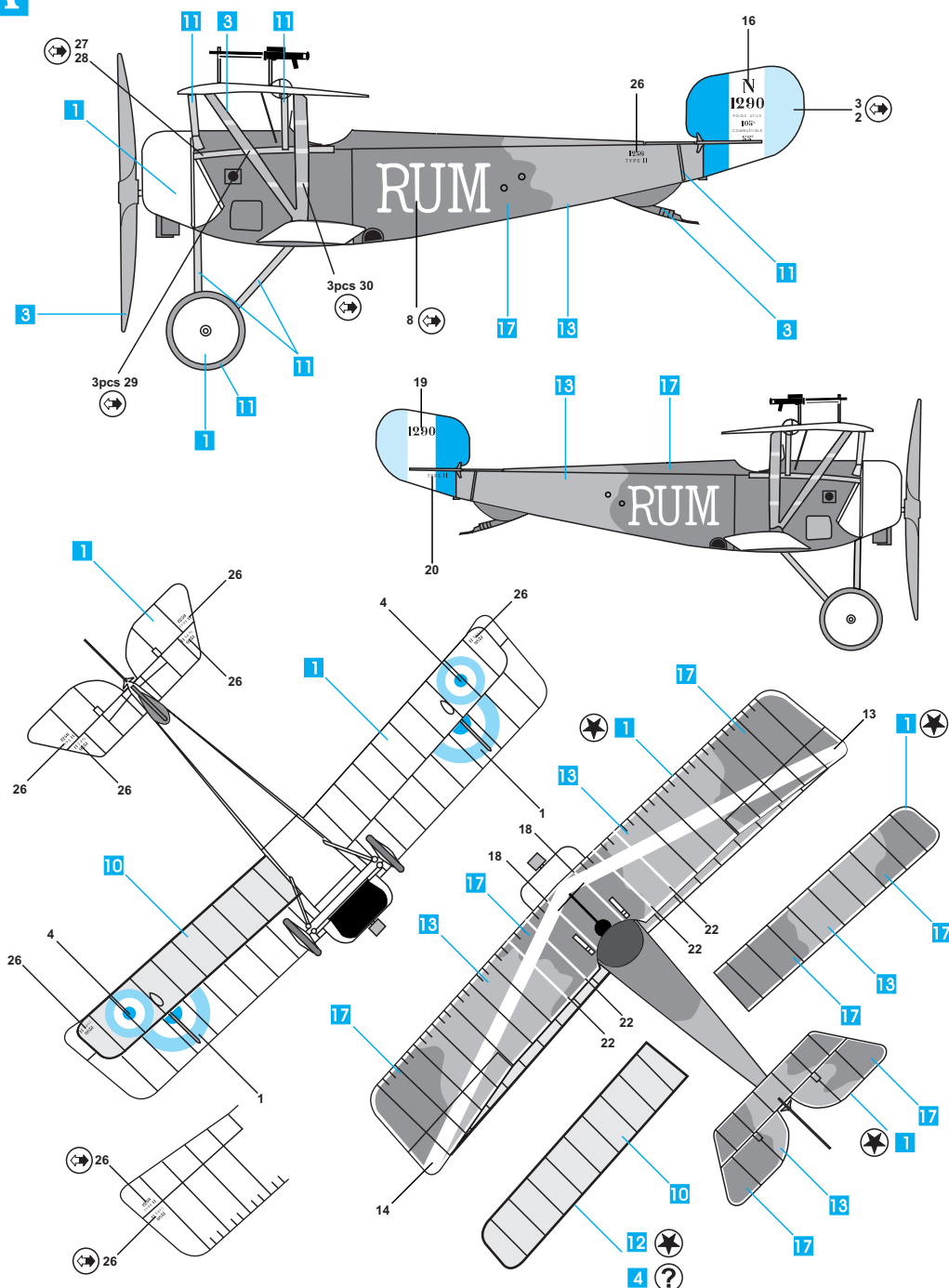

1 ALUMINIUM / ALUMINIUM / ALUMINIUM / HLIŇIK	11 GRAY / GRAU / GRIS / ŠEDÁ
3 SAND / SANDBAUN / SABLE / DŘEVO	12 BROWN / BRAUN / BRUN / HNĚDÁ
4 BLACK / SCHWARZ / NOIR / ČERNÁ	13 GREEN / GRÜN / VERT / ZELENÁ
10 CLEAR DOPED LINEN / LINNEN / TOILE / PLÁTNO	17 KHAKI / KHAKI / KAKI / KHAKI

* OZNAČENÍ A ZBARVENÍ
MARKIERUNGEN UND BEMALUNG

* MARKING & PAINTING *
DECORATION ET PEINTURE

B Escadrille N12, 1916

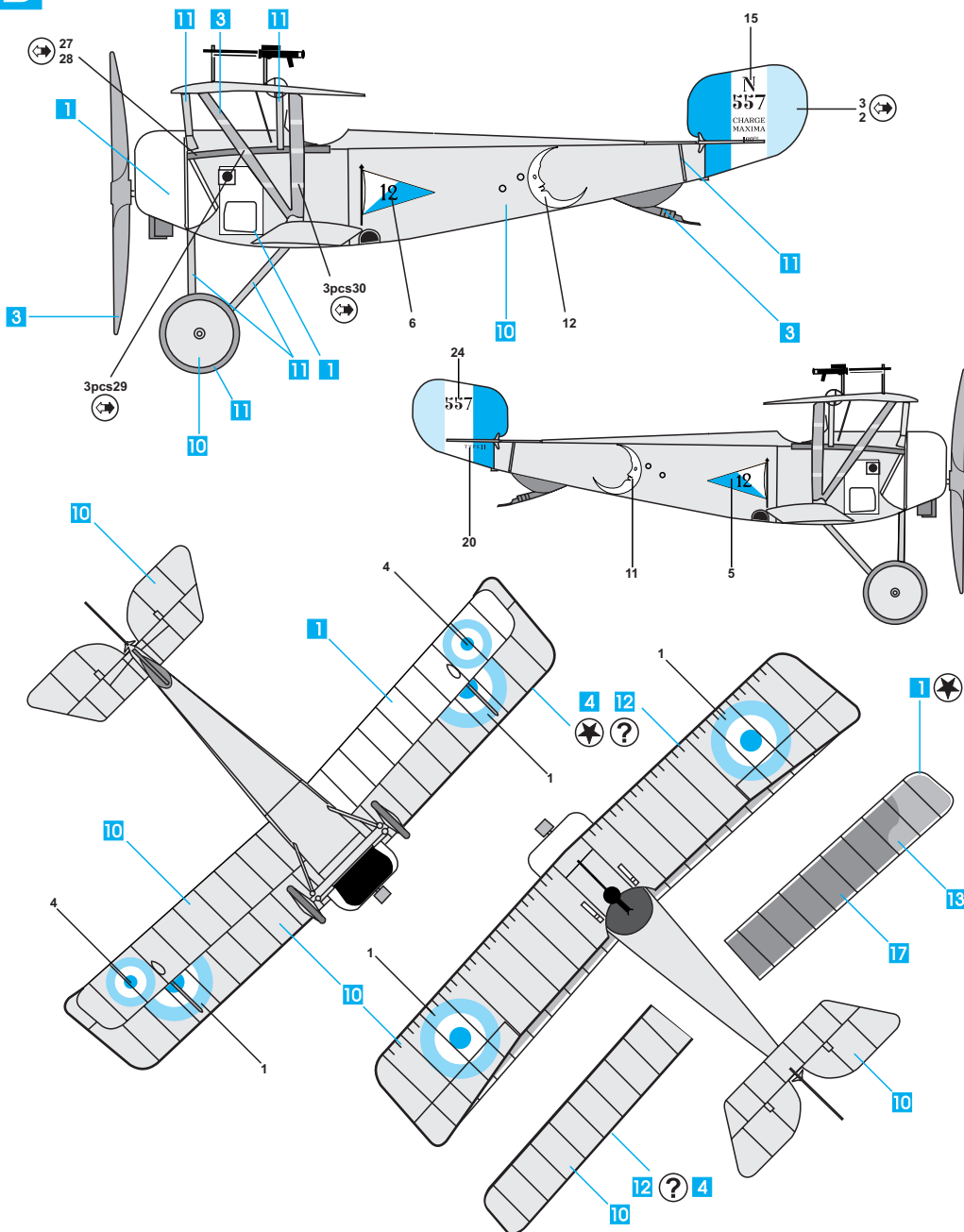

1	ALUMINIUM / ALUMINIUM / ALUMINIUM / HLINÍK	11	GRAY / GRAU / GRIS / ŠEDÁ
3	SAND / SANDBAUN / SABLE / DŘEVO	12	BROWN / BRAUN / BRUN / HNĚDÁ
4	BLACK / SCHWARZ / NOIR / ČERNÁ	13	GREEN / GRÜN / VERT / ZELENÁ
10	CLEAR DOPED LINEN / LINNEN / TOILE / PLÁTNO	17	KHAKI / KHAKI / KAKI / KHAKI

* OZNAČENÍ A ZBARVENÍ *
 MARKIERUNGEN UND BEMALUNG

* MARKING & PAINTING *
 DECORATION ET PEINTURE

C Lt.Armand de Turenne, Escadrille N48, 1916

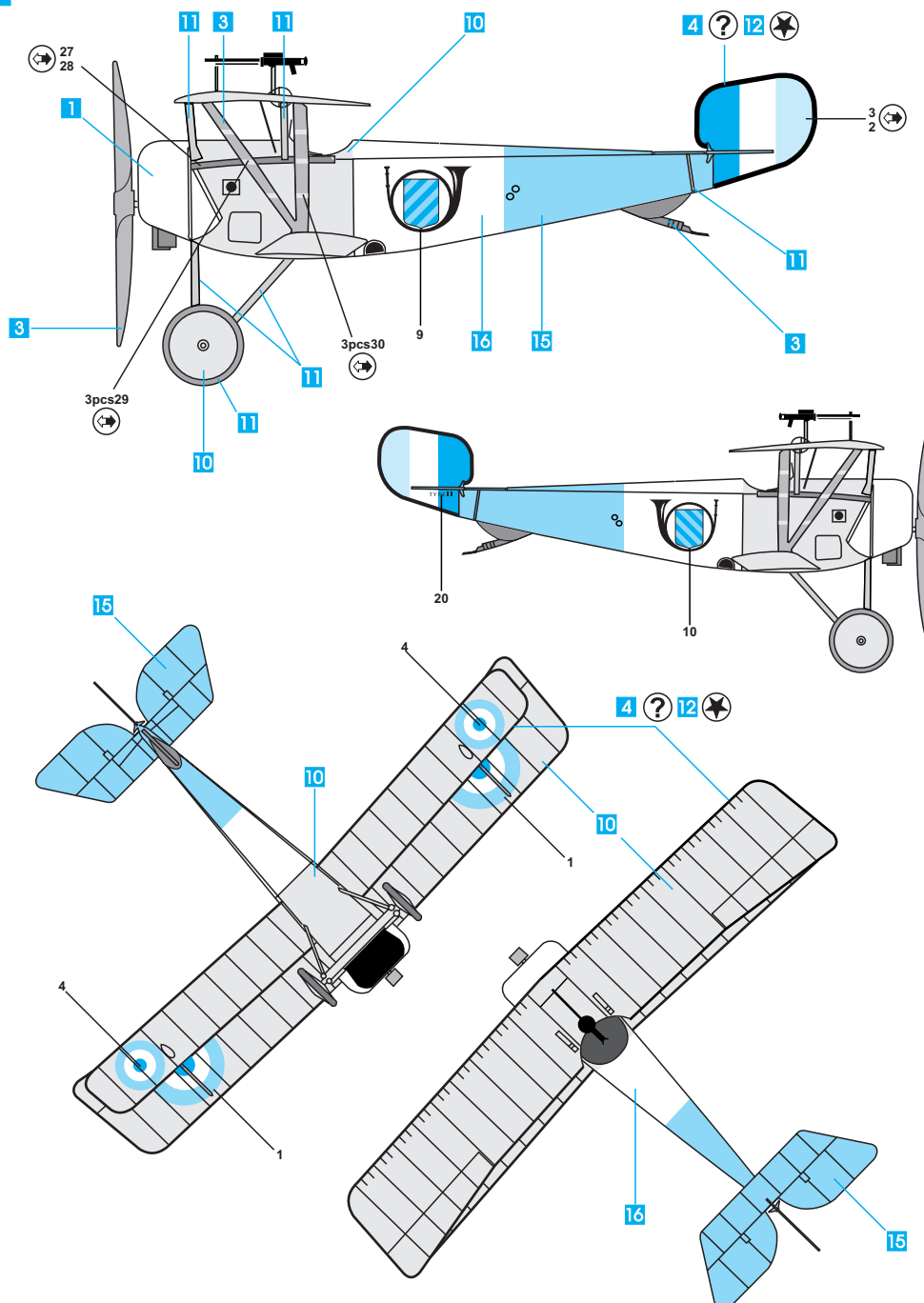

1	ALUMINIUM / ALUMINIUM / ALUMINIUM / HLIŇIK	11	GRAY / GRAU / GRIS / ŠEDÁ
3	SAND / SANDBAUN / SABLE / DŘEVO	12	BROWN / BRAUN / BRUN / HNĚDÁ
4	BLACK / SCHWARZ / NOIR / ČERNÁ	15	RED / ROT / ROUGE / ČERVENÁ
10	CLEAR DOPED LINEN / LINNEN / TOILE / PLÁTNO	16	WHITE / WEIß / BLANC / BÍLÁ

* OZNAČENÍ A ZBARVENÍ *
 MARKIERUNGEN UND BEMALUNG

* MARKING & PAINTING *
 DECORATION ET PEINTURE

D Lt.Armand de Turenne,Escadrille N48, 1916-17

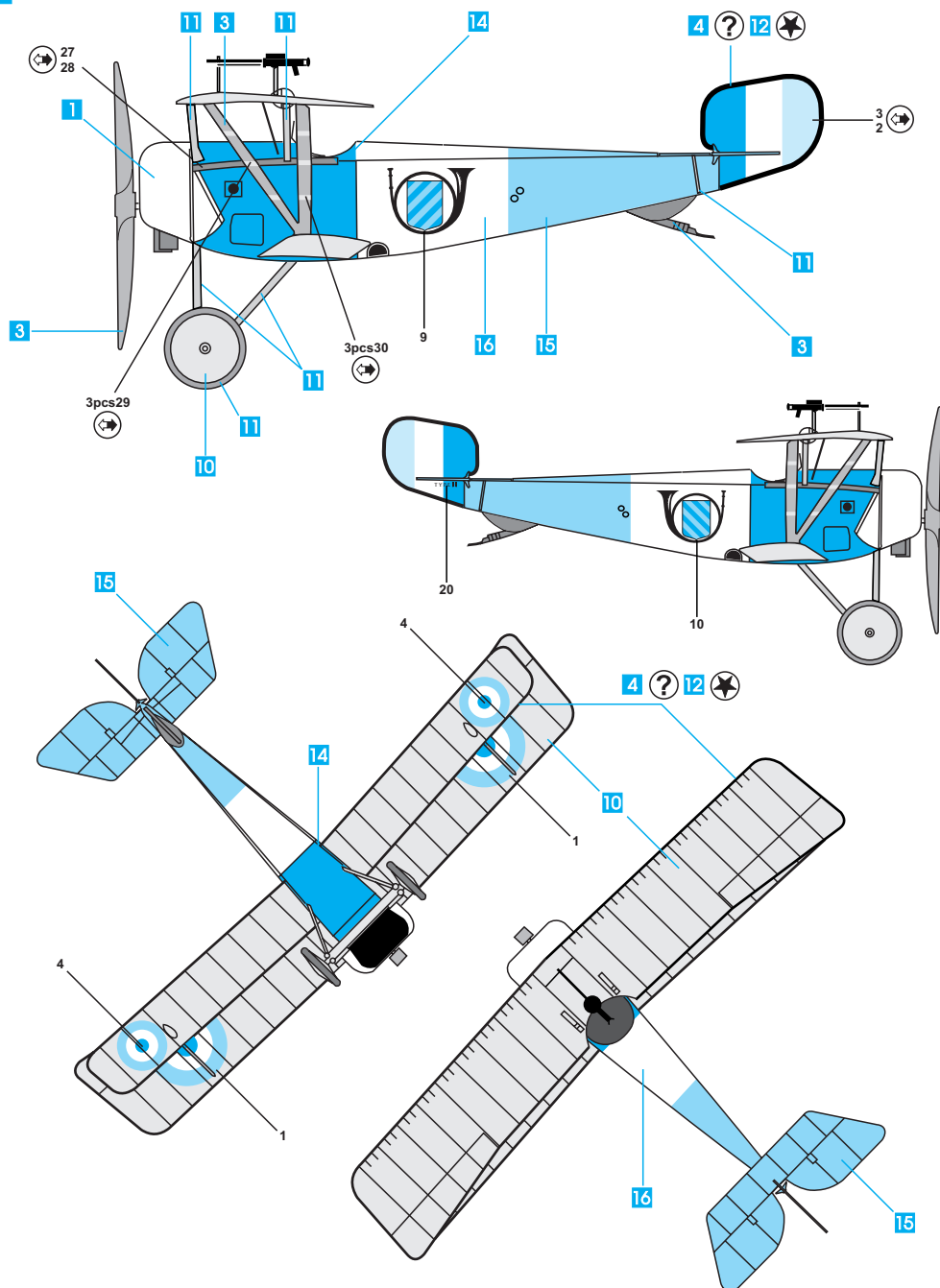

1	ALUMINIUM / ALUMINIUM / ALUMINIUM / HLINÍK	12	BROWN / BRAUN / BRUN / HNĚDÁ
3	SAND / SANDBAUN / SABLE / DŘEVO	14	BLUE / BLAU / BLEU / MODRÁ
4	BLACK / SCHWARZ / NOIR / ČERNÁ	15	RED / ROT / ROUGE / ČERVENÁ
10	CLEAR DOPED LINEN / LINNEN / TOILE / PLÁTNO	16	WHITE / WEIß / BLANC / BÍLÁ
11	GRAY / GRAU / GRIS / ŠEDÁ		

* OZNAČENÍ A ZBARVENÍ *
 MARKIERUNGEN UND BEMALUNG

* MARKING & PAINTING *
 DECORATION ET PEINTURE

E Sgt. Raoul Lufbery, Escadrille américaine N124, 1916

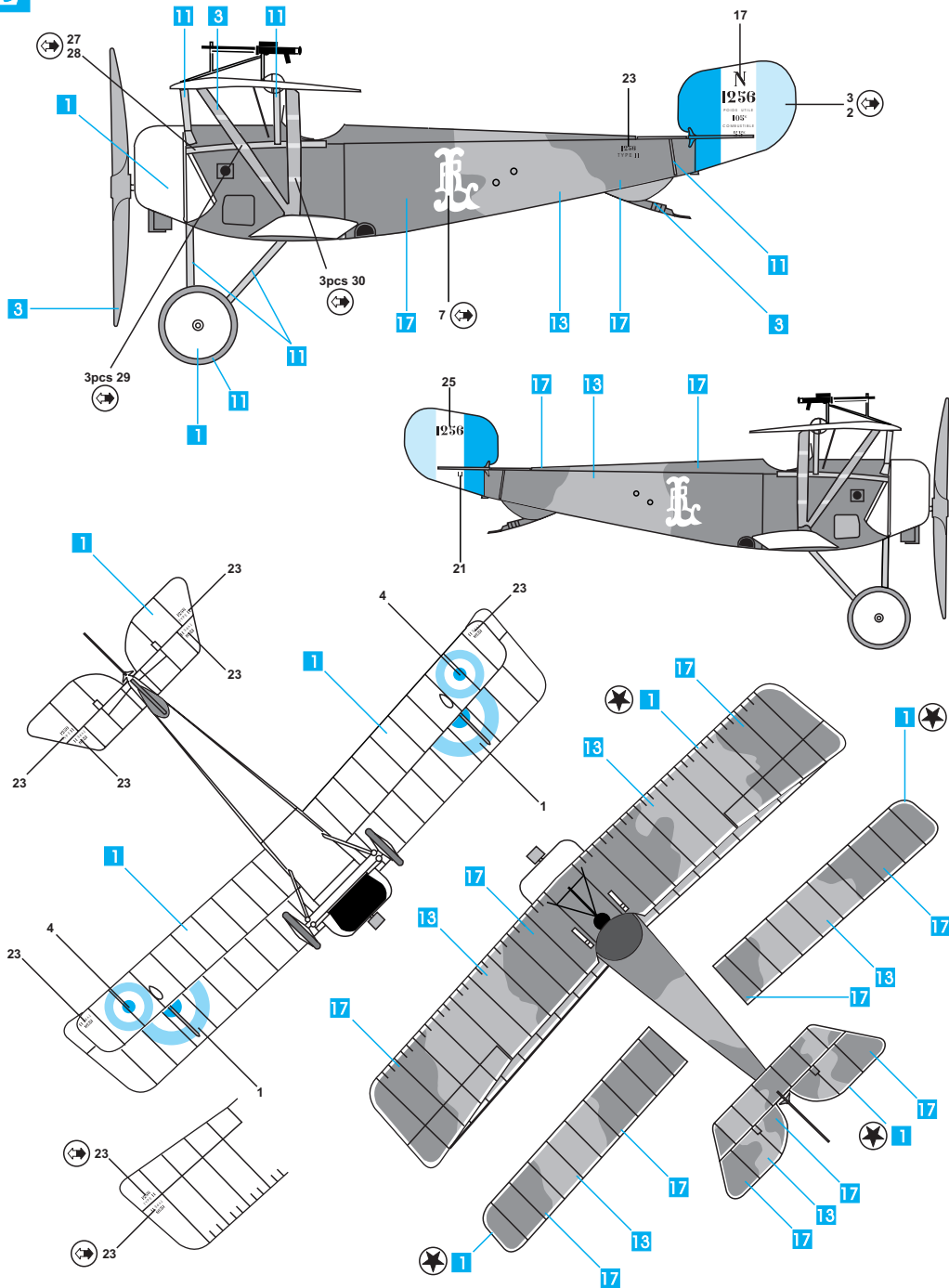

1 ALUMINIUM / ALUMINIUM / ALUMINIUM / HLINÍK	13 GREEN / GRÜN / VERT / ZELENÁ
3 SAND / SANDBAUN / SABLE / DŘEVO	17 KHAKI / KHAKI / KAKI / KHAKI
11 GRAY / GRAU / GRIS / ŠEDÁ	