



## IDF M60A1

## Magach 6B

**\*\*Special thanks to Robert Goldman, Robert Skipper, Yoav Efrati and other friends of IDF.**

The Sinai Peninsula was to see multiple small-scale conflicts between Israel and Egypt after the end of the Six Day War in 1967. In 1971, the Israeli Defense Force (IDF) procured 150 M60A1's from the United States renaming them the Magach 6. This change was due, in part, to the superior speed the M60A1 had over the British Centurion, which the IDF had procured from the Great Britain.

The M60A1 and its counterpart the M48A5 (Magach 5) were deployed in the open terrain of the Sinai Peninsula during the years of the Israeli occupation of the Sinai and construction of a levy wall along the Suez Canal to defend against the Egypt.

In 1973 the fourth Mid East crisis known as the Yom Kippur War, the Ramadan War, or the 1973 Arab-Israeli War occurred. This was initiated with a surprise attack on the Israeli Bar Lev Line: a line of anti-tank trenches and sand mounds that ran along the Eastern coast of the Suez Canal. These sand/trench fortifications were easily breached by the Egyptian Army using high-pressure water cannon during Operations Badr. Anticipating a counterattack from the IDF the Egyptian Army was equipped with large numbers of Soviet made 9M14 Malyutka( a wire-guided anti-tank missile) and RPG-7's. Ambushed by the Egyptian army, Israeli armor suffered heavy losses in the early days of the conflict.

After the Yom Kippur War, the IDF continued its procurement of M48A5's and M60A1's to replace the losses through attrition of war. By the late 70's, the IDF started to implement the reactive armor developed by the Rafael Company to prevent further losses from anti armor weapons. These metal boxes (installed on the exterior of armor vehicles) contained explosives, which dispersed the impact and damage of an incoming shell. In 1980, the IDF upgraded the Magach 6 with a continental AVDS-1970-2C Diesel engine and other components re-designating it the Magach 6B. In 1982, the upgraded Magach 6B saw battle in the Lebanon war. The United States Marine Corp upgraded 170 of its M60A1's based in part on the modifications used on the Magach 6. This included receiving reactive armor upgrades.

シナイ半島では、1967年に6日戦争が終結した後も、イスラエルとエジプトとの間に幾度となく小規模な戦闘が発生していました。1971年にIDF(イスラエル国防軍)は米国から150輛のM60A1戦車を調達しマガフ6と名付けました。M60A1は、以前に英国から調達したセンチリオン戦車に比べて速度の面で優れていました。

M60A1とM48A5(マガフ5)は、イスラエルによるシナイ半島の占領とエジプトに対する防御のためにスエズ運河沿いに壁を建設する間、シナイ半島の広大な地域に配備されたのでした。1973年、ヨム・キプール戦争、またはラマダン戦争、1973年、1973年のアラブ・イスラエル戦争ともよばれる第四次中東戦争が勃発します。この戦争は、エジプト軍によるバーレブ・ライン(スエズ運河東岸に沿って構築された対エジプト拠点群)に対しての不意の攻撃で始まりました。対戦車用の溝や土塁などの防御施設は、エジプト軍の使用した高圧放水砲によって簡単に無力化されてしまいました。イスラエル軍の反撃を予想していたエジプト軍は、ソビエト製マリユートカ対戦車ミサイルやRPG-7対戦車ロケットを大量に配備し、イスラエル軍を待ち伏せしており、その結果イスラエル軍は開戦初頭で甚大な損害を被ったのでした。

ヨム・キプール戦争の後も、イスラエル国防軍は戦闘による損失を補うためM48A5とM60A1の調達を続けました。そして対戦車兵器による更なる損害を防ぐために、ラファエル社によって開発されたリアクティブアーマーの装備を1970年代後半までに開始します。装甲車両の外側に装着されるこれらの金属製ボックスには爆薬が入っており、砲弾命中による衝撃とダメージを分散させる効果がありました。1980年にIDFは、コンチネンタル社製AVDS-1970-2Cディーゼルエンジンや新たな変速機の搭載によってマガフ6をアップグレードさせ、それらにマガフ6Bの名称を与えました。1982年、マガフ6Bはレバノン戦争に投入されました。アメリカ海兵隊は170輛のM60A1にマガフ6と同様のアップグレードを施し、その中にはリアクティブアーマーの装備が含まれていたのです。



1967年六日戰爭結束後的數年之間，以色列與埃及在西奈半島上仍然持續著小規模的軍事衝突。1971年以色列向美國購得150輛M60A1戰車(以色列將其命名為Magach 6)，由於M60A1在速度上優於從英國取得的百夫長戰車，因此M60A1連同M48A5(以色列命名Magach 5)被部署於地勢較為開展的西奈半島地區。

在以色列佔領西奈半島幾年的時間內，為了防範埃及的進攻，沿著蘇彝士運河構築了綿長的沙堆防禦工事。1973年猶太教的贖罪日當天第四次中東戰爭爆發，埃及與敘利亞的地面部隊分別由南北兩個方向對以色列發動奇襲。原本以色列倚重的沙堆工事，被埃及地面部隊輕易的以高壓水柱所摧毀。由於預期以色列裝甲部隊將進行反擊，埃及先頭部隊攜帶了大量的9M14(北約代號AT-3)與RPG-7等反裝甲武器。在裝甲車與步兵的伏擊下，在戰爭爆發的最初的幾日內便讓以色列裝甲部隊蒙受了重大的損失。

贖罪日戰爭結束之後，以色列陸續再引進M48A5與M60A1填補作戰的損失。為了防禦單兵反裝甲武器的攻擊，以色列在1970年代末開始為戰車增設了由Rafael公司開發的反應式裝甲。這種狀似在戰車表面排列金屬盒子的反應裝甲，是利用裝甲夾層中炸藥產生爆炸，來分散來襲砲彈對車體的損害。1980年，以色列為Magach 6更換大陸汽車的AVDS-1790-2C柴油發動機及改進了部分組件，修改過後被稱為Magach 6B，1982年經過修改升級後的Magach 6B便首次在黎巴嫩戰爭中登場。由於以色列在實戰中運用Magach 6所累積的經驗，日後也成為美國修改M60A1的依據，同時為海軍陸戰隊的170輛M60A1加裝上反應裝甲。

### Illustration:圖示說明



### Method For Applying Decals:

1. Clean Model Surface With Wet Cloth.
2. Cut Out Of Decal Sheet And Dip Them In Warm Water For 15 Seconds.
3. Place it on proper position on model.
4. Slide off base paper leaving decals On Model With Wet Finger Tip.
5. Move Decals To Exact Position, Push Out Excess Water Under Decal With Soft Cotton Cloth.
6. When Decals Get Dry Then Complete.

### 水貼紙使用說明:

1. 將模型表面擦乾淨
2. 將貼紙剪下泡入溫水中浸泡約15秒
3. 將泡濕之貼紙取出置於欲貼處旁
4. 用指尖輕推貼紙表面使其滑出底紙
5. 將貼紙調整至適當位置並輕擦拭水份
6. 待其自然乾燥後即完成

### Color list: 塗料表

Color	Brand	Gunze Sangyo			Humbrol	Revell	Lifecolor
		Hobby Color	Mr.Color	Mr.Color Spray			
Brass	黃銅	H9	C9	J9	54	92	LC75
Bronze green	青銅綠		TC10				
Duck egg green	鴨蛋綠	H74	C26		23		UA95
Flat black	消光黑	H12	C33	J33	33	8	LC02
Flat red	消光紅	H13			174		LC06
Flat white	消光白	H11	C62	J62	34	05	LC01
IDF Gray 2	以色列灰		C529/TC20		72		UA902
Red	紅	H3	C3	J3	19	31	LC56
Sail color	帆布	H85	C45		28		UA099
Silver	銀	H8	C8	J8	11	90	LC74
Steel	黑鐵	H18	C28	J28	53	91	LC76
Tire black	輪胎黑	H77	C137		85	302	LC02
Wood brown	木棕	H37	C43		110		UA85



# M60 "Patton" Main Battle Tank

**M60 (1959)**

Mounted a M48 turret with 105mm tank gun.

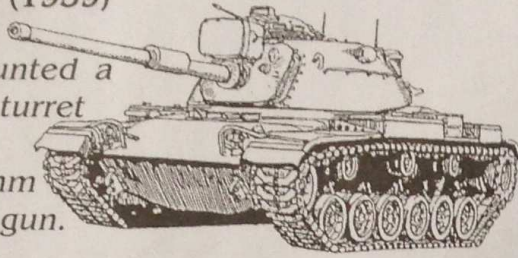

**M728 CEV (Combat Engineer Vehicle)**



**M60 AVLB (Armored Vehicle -Launched Bridge )**



**M60A1**

(1962)  
New turret

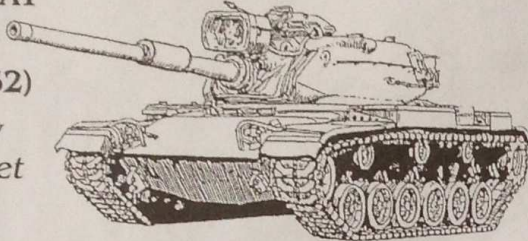

■ **Israel**  
**Magach 6**  
Modified M60A1  
Outfitted with ERA

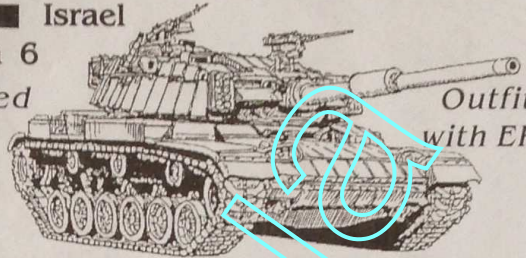

**M60A2 (1972)**

152mm gun/launcher

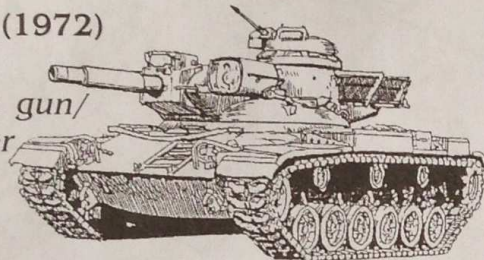

**Magach 7A**  
Outfitted with armor module and side skirt.

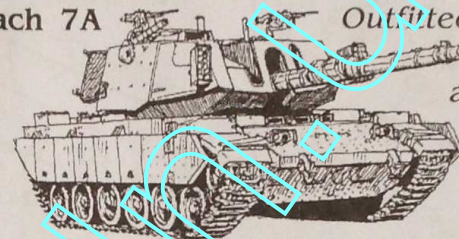

New single-pin tracks.

**M60A1 RISE (1971)**

Improved M60A1  
Outfitted with explosive reactive armor during the First Gulf War.



**Magach 7C**  
Arrowhead-shaped armor modules were fitted to the front of turret.

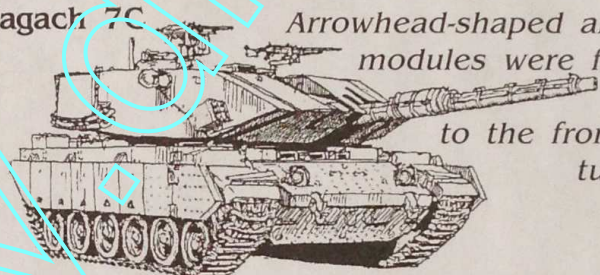

**M60A3 (1978)**

Upgraded M60A1 RISE



■ **Israel**  
**Sabra I**  
Developed from Magach.

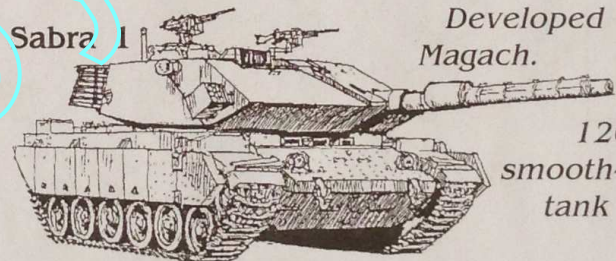

120mm smooth-bore tank gun.

**Super M60 (1981)**

Developed by an American civilian company.

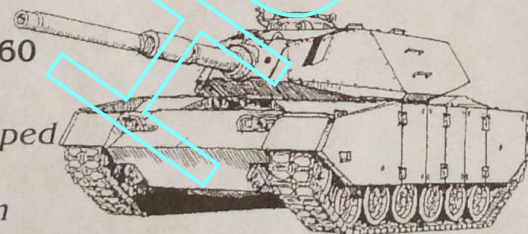

■ **Turkey**  
Modernized M60  
Equipped with main gun of Sabra.

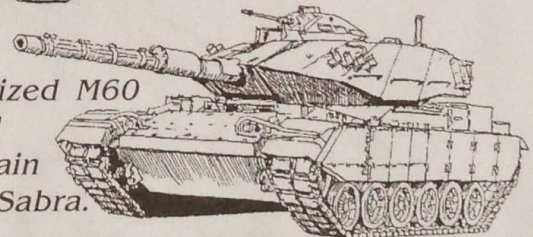

**M60-2000**

Mounted a M1 Abrams turret.

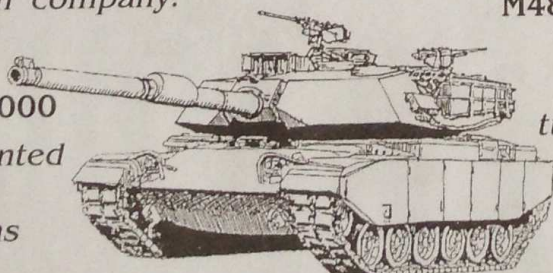

■ **Republic of China (Taiwan)**  
**M48H/CM-11 勇虎 "Brave Tiger"**  
A M48A3 turret equipped with a 105 mm tank gun on M60A3 hull.



*Shin.ueda*

上田 信



1

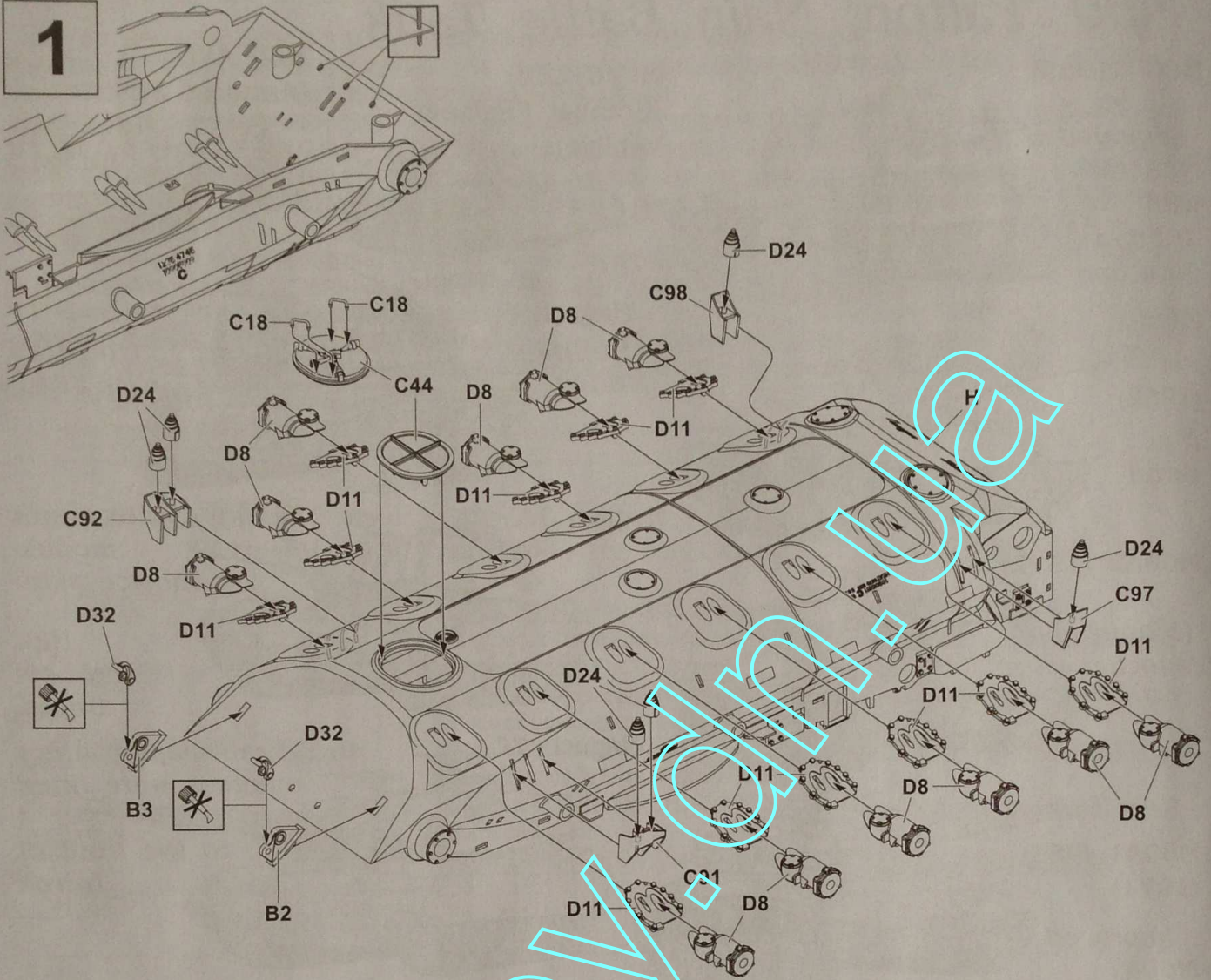

2

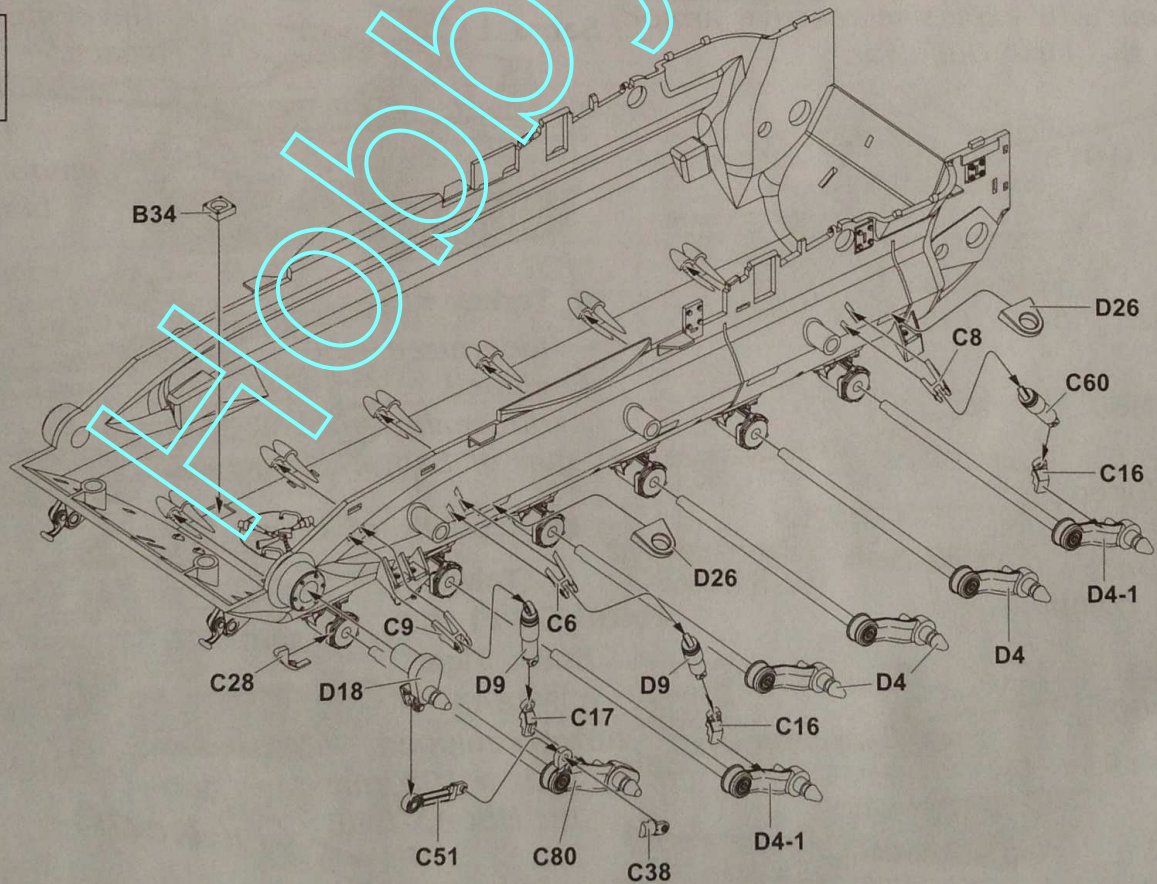



3

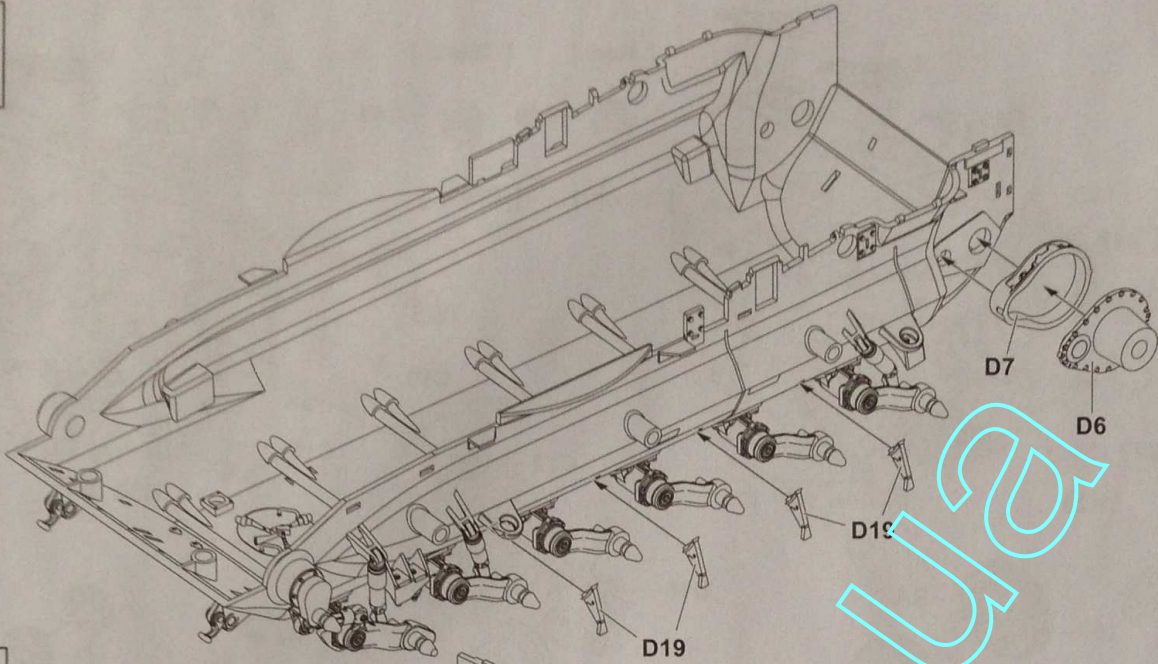

4

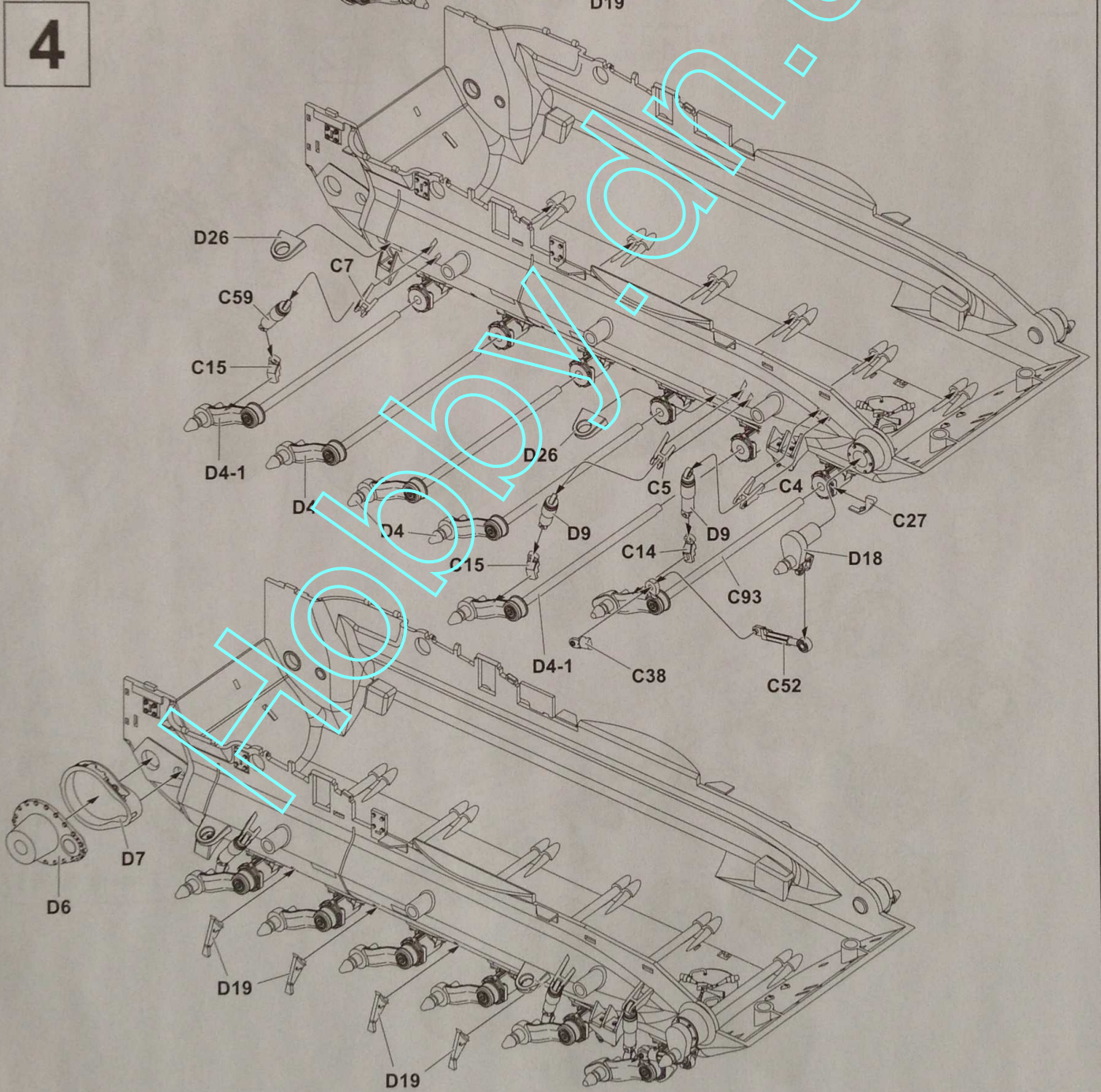



5

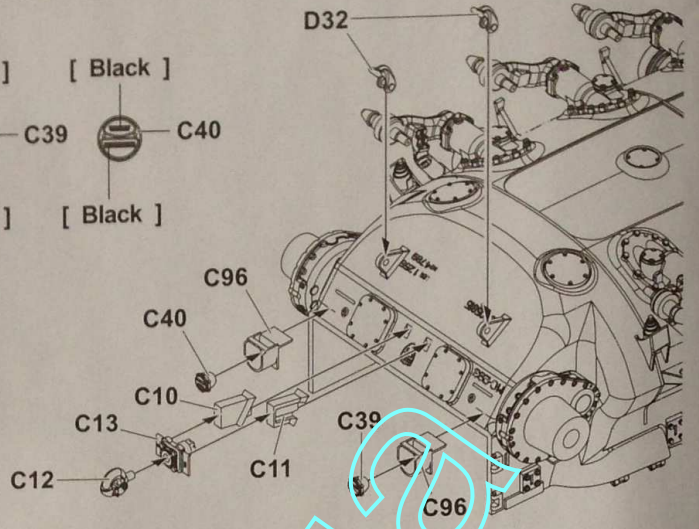
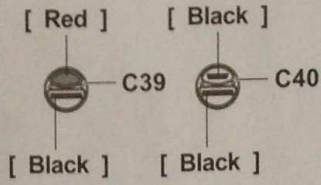
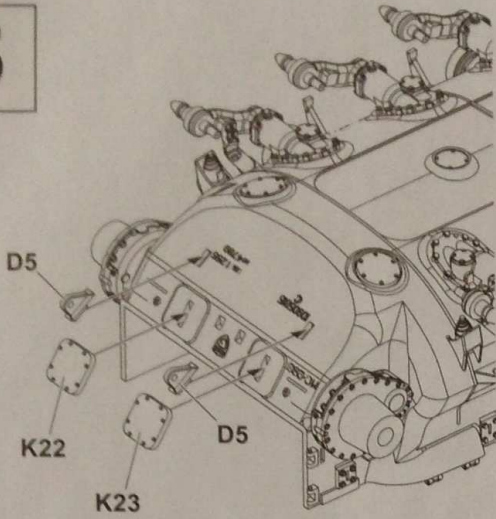

6

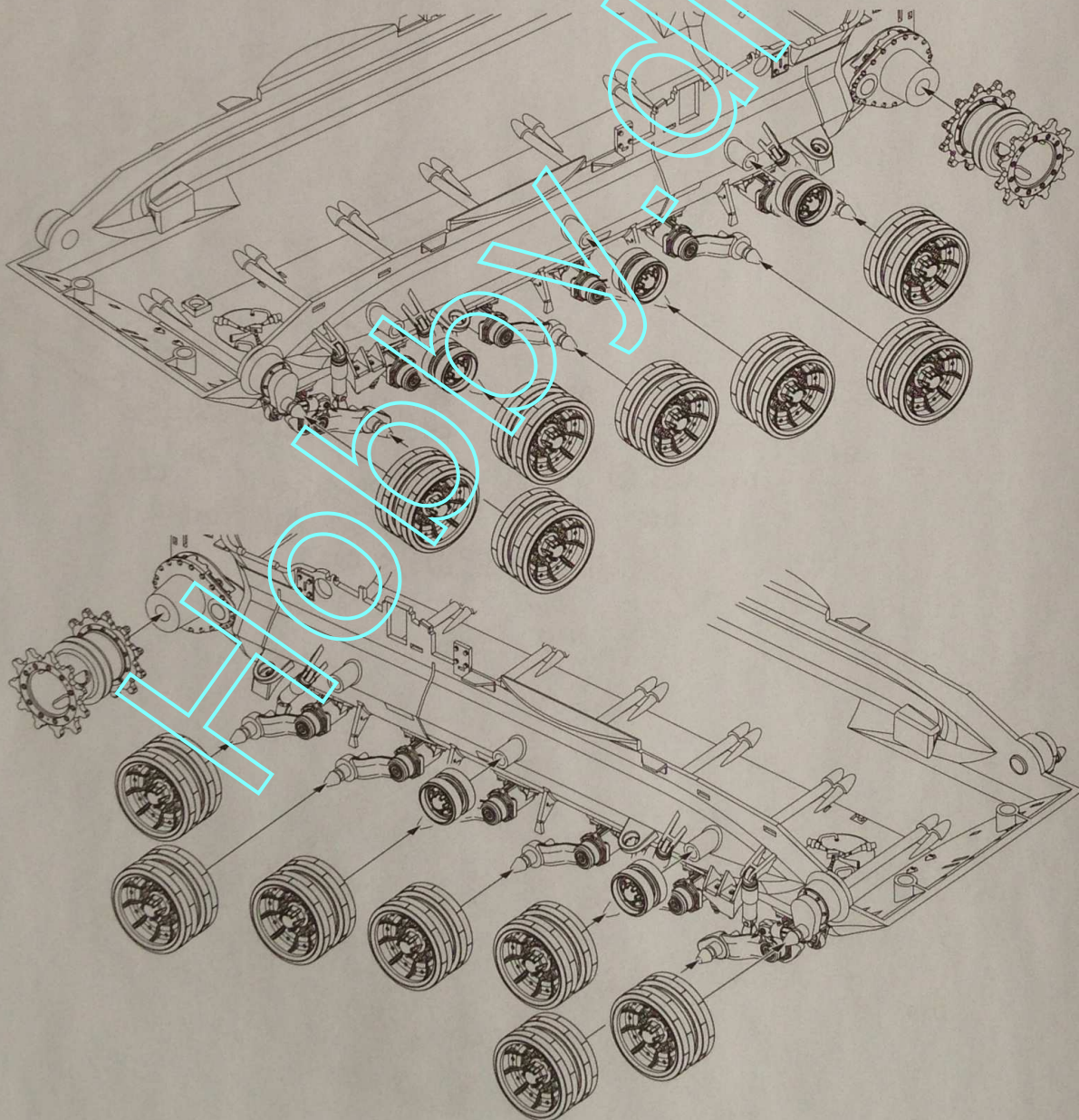
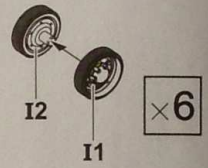
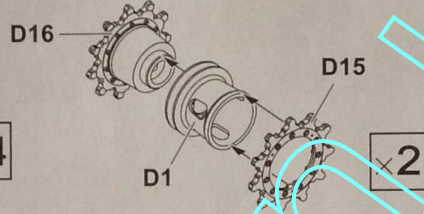
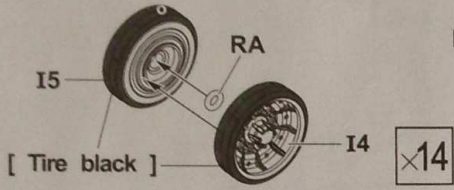



7

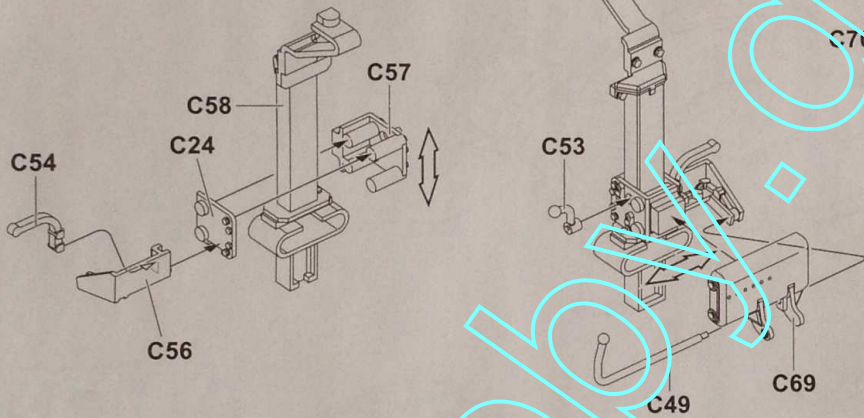
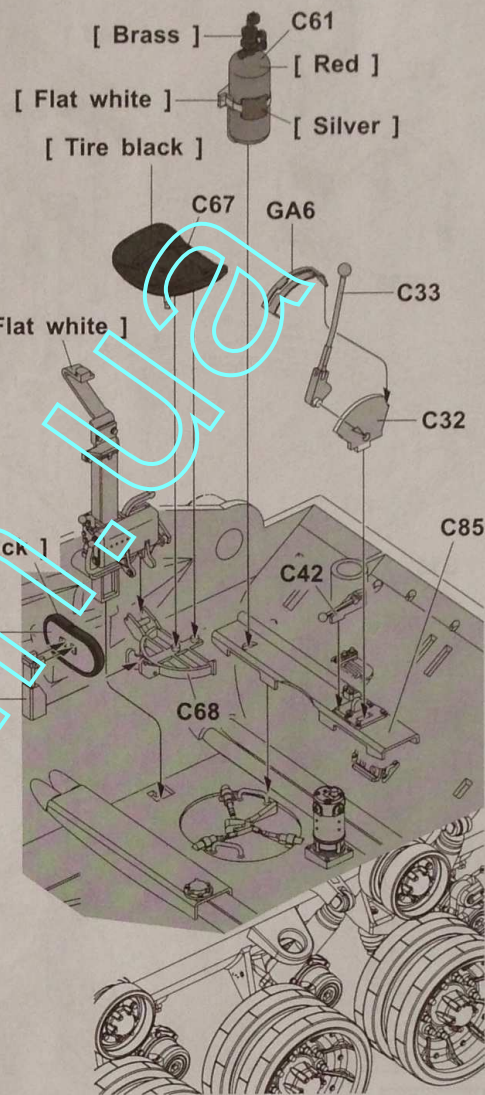
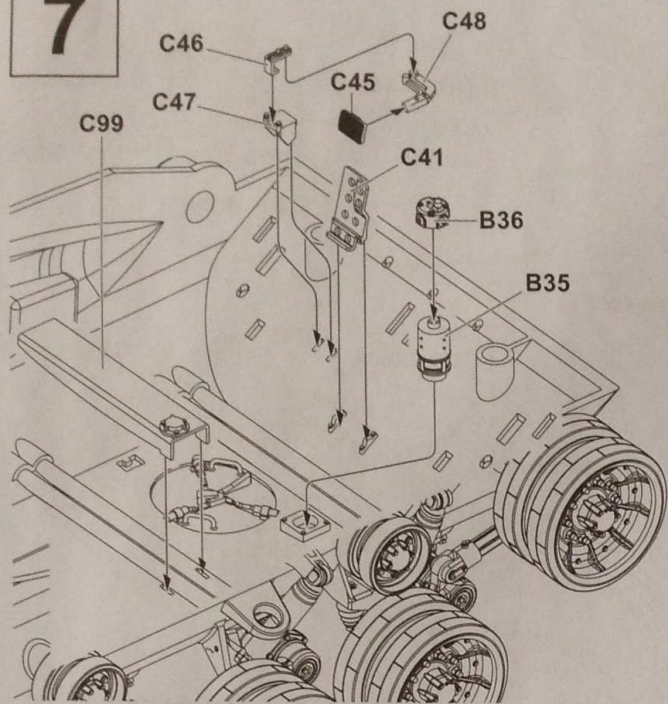

8

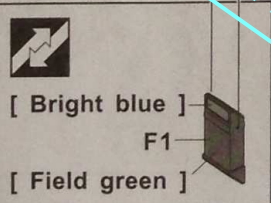
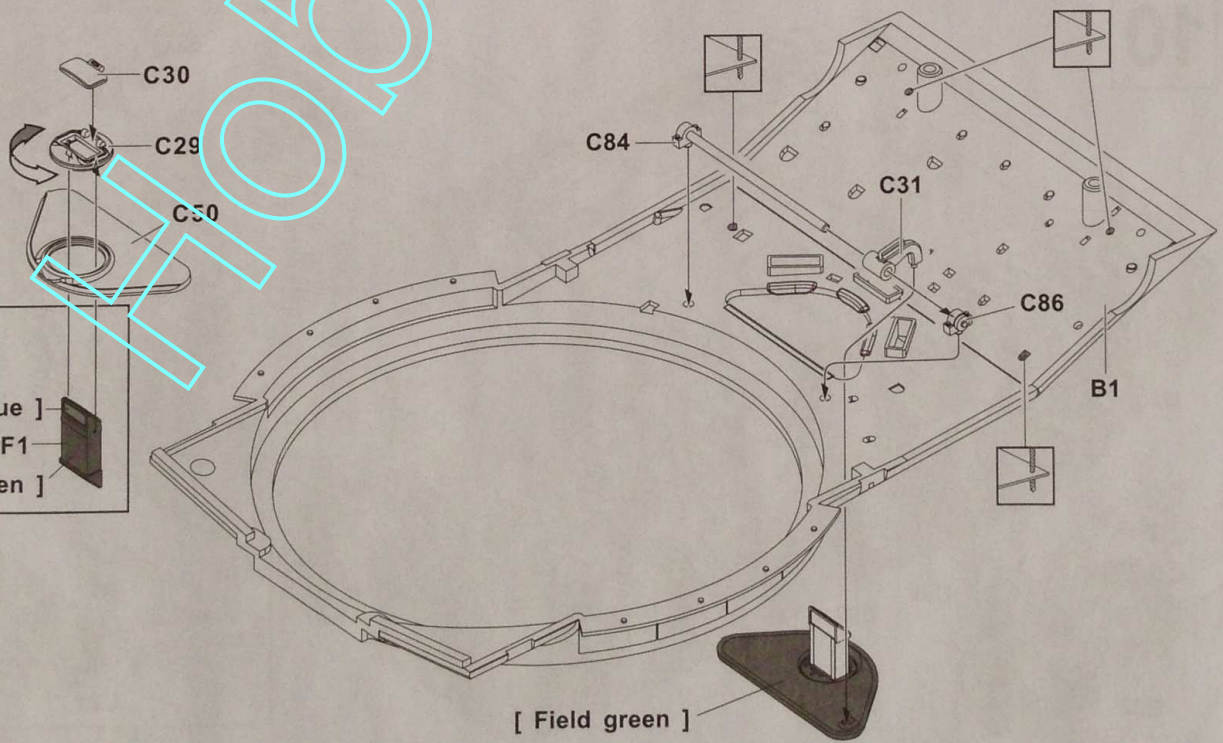

[ Bright blue ]  
F1  
[ Field green ]

[ Field green ]



9

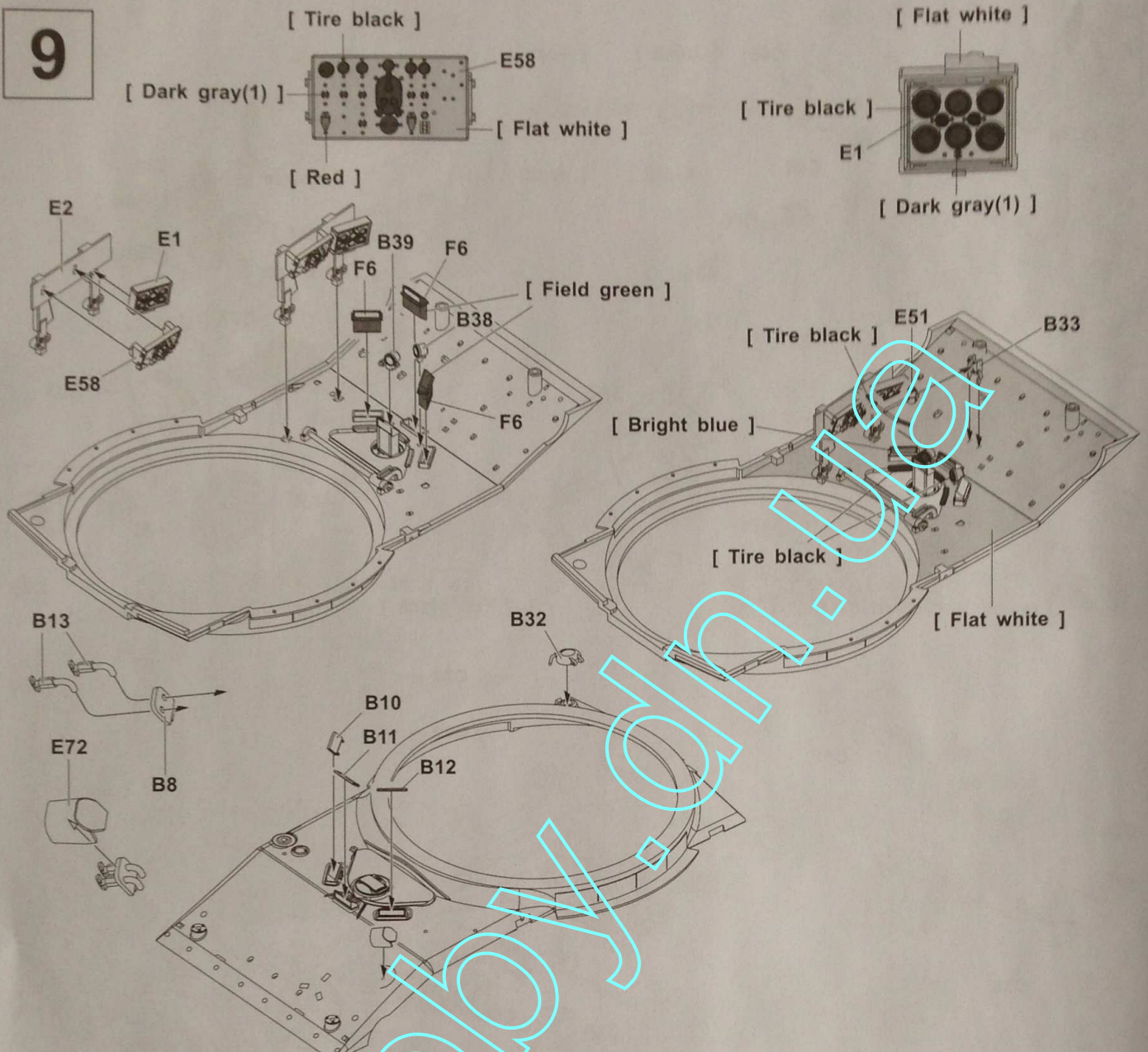

10

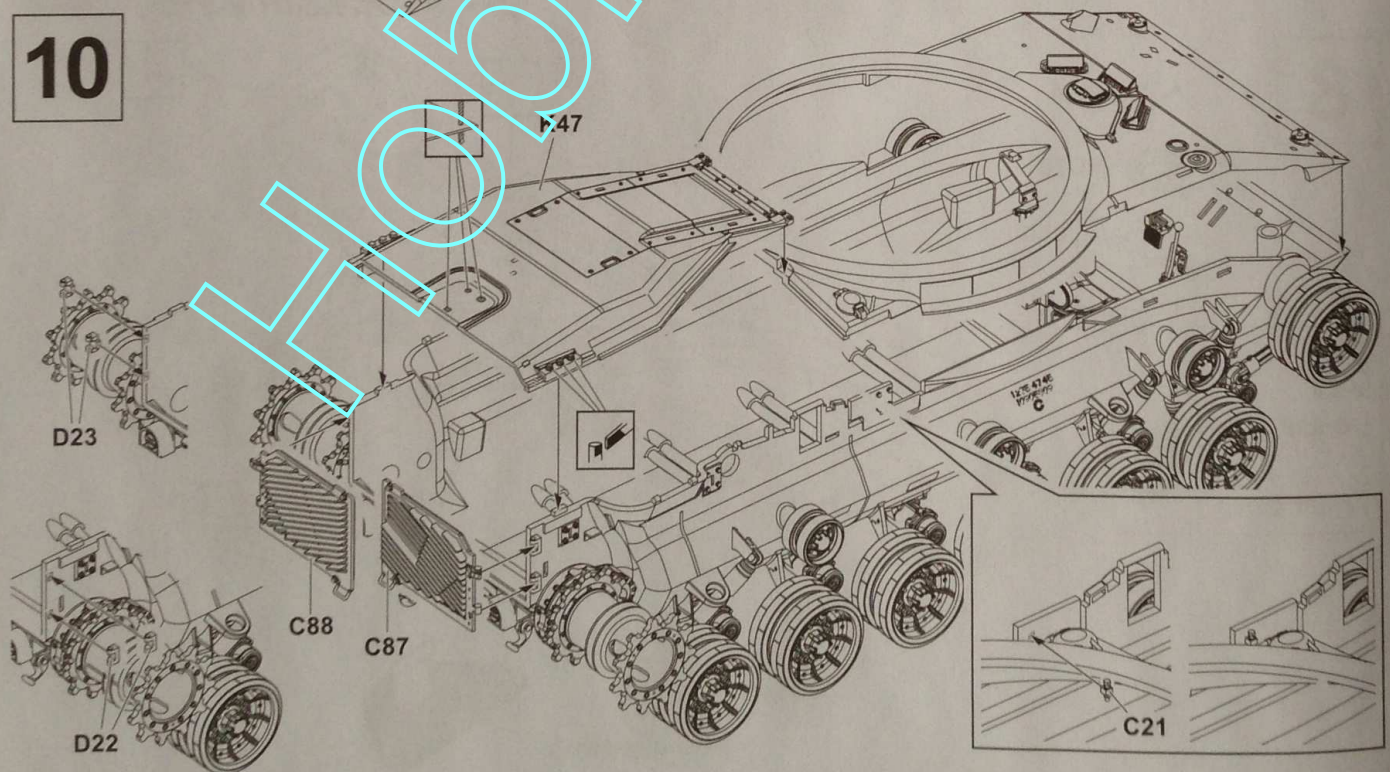



11

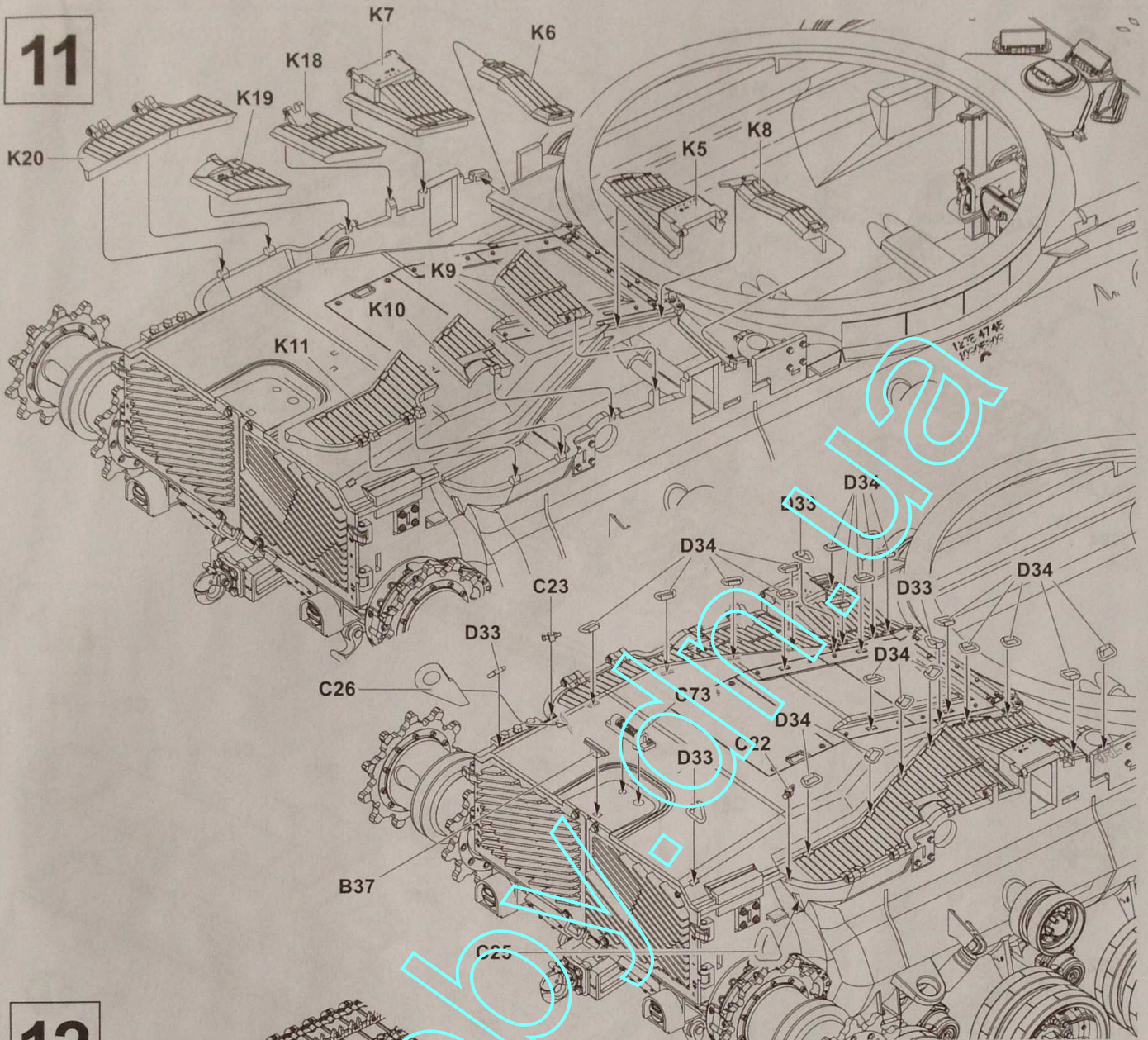

12

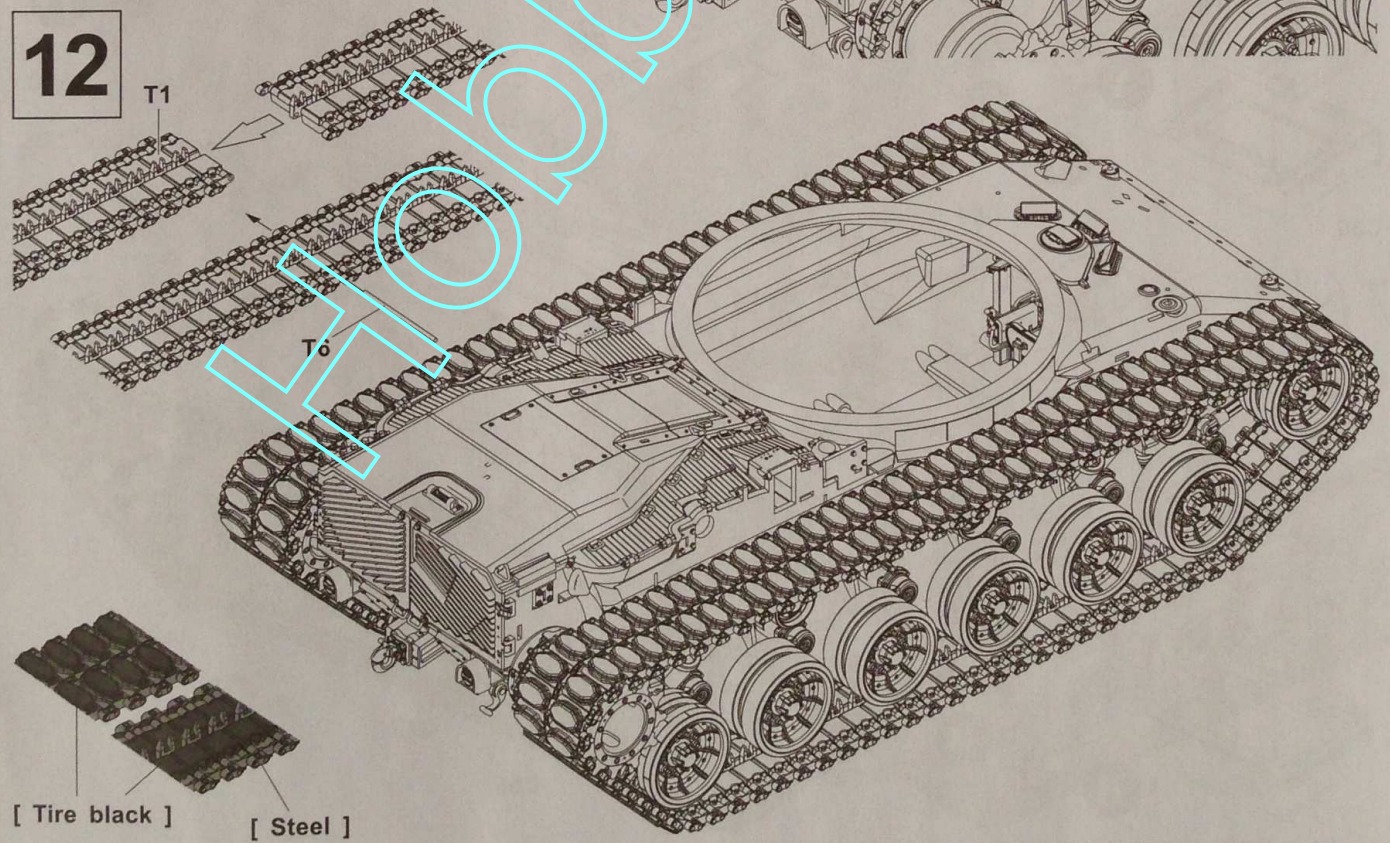



13

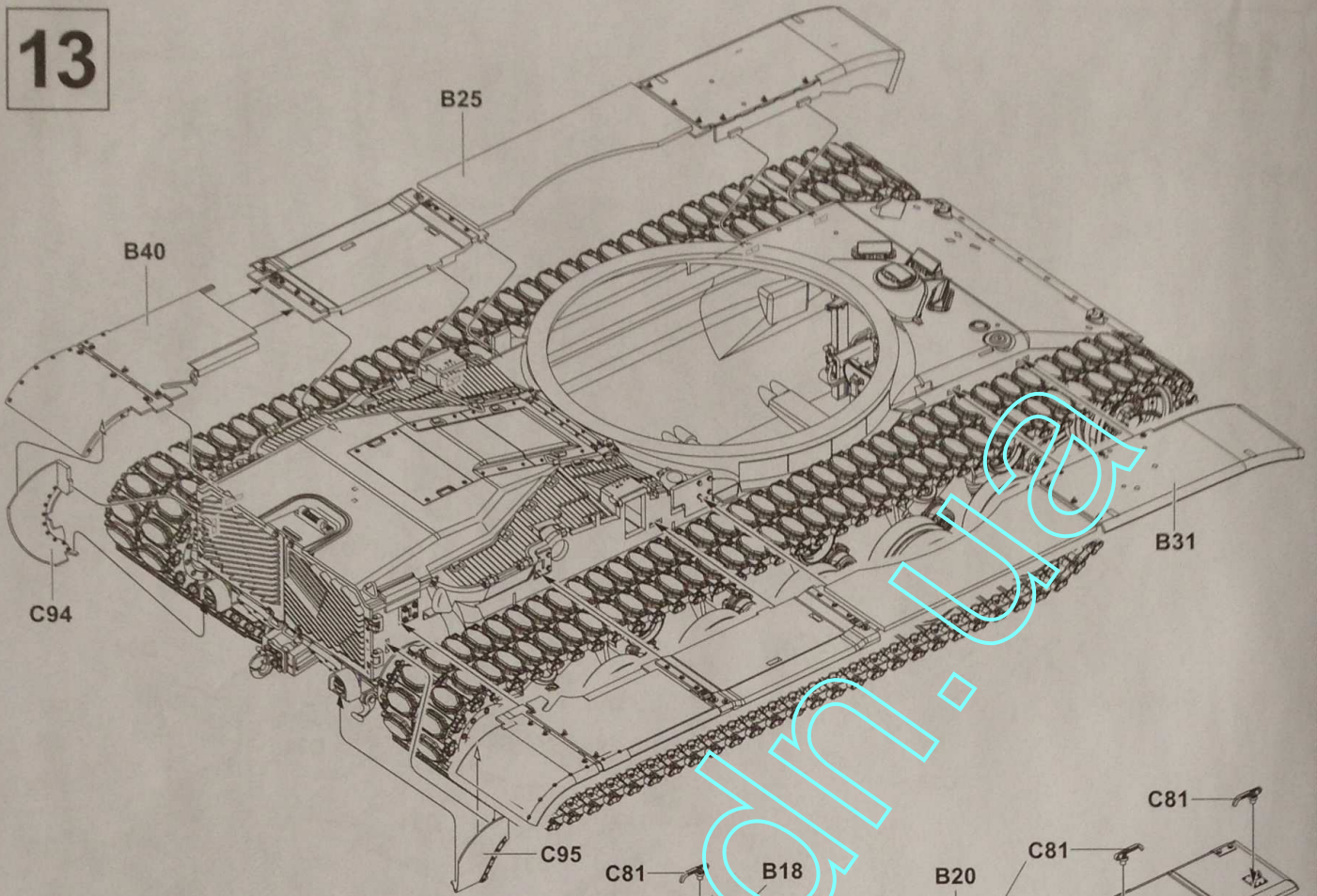

14

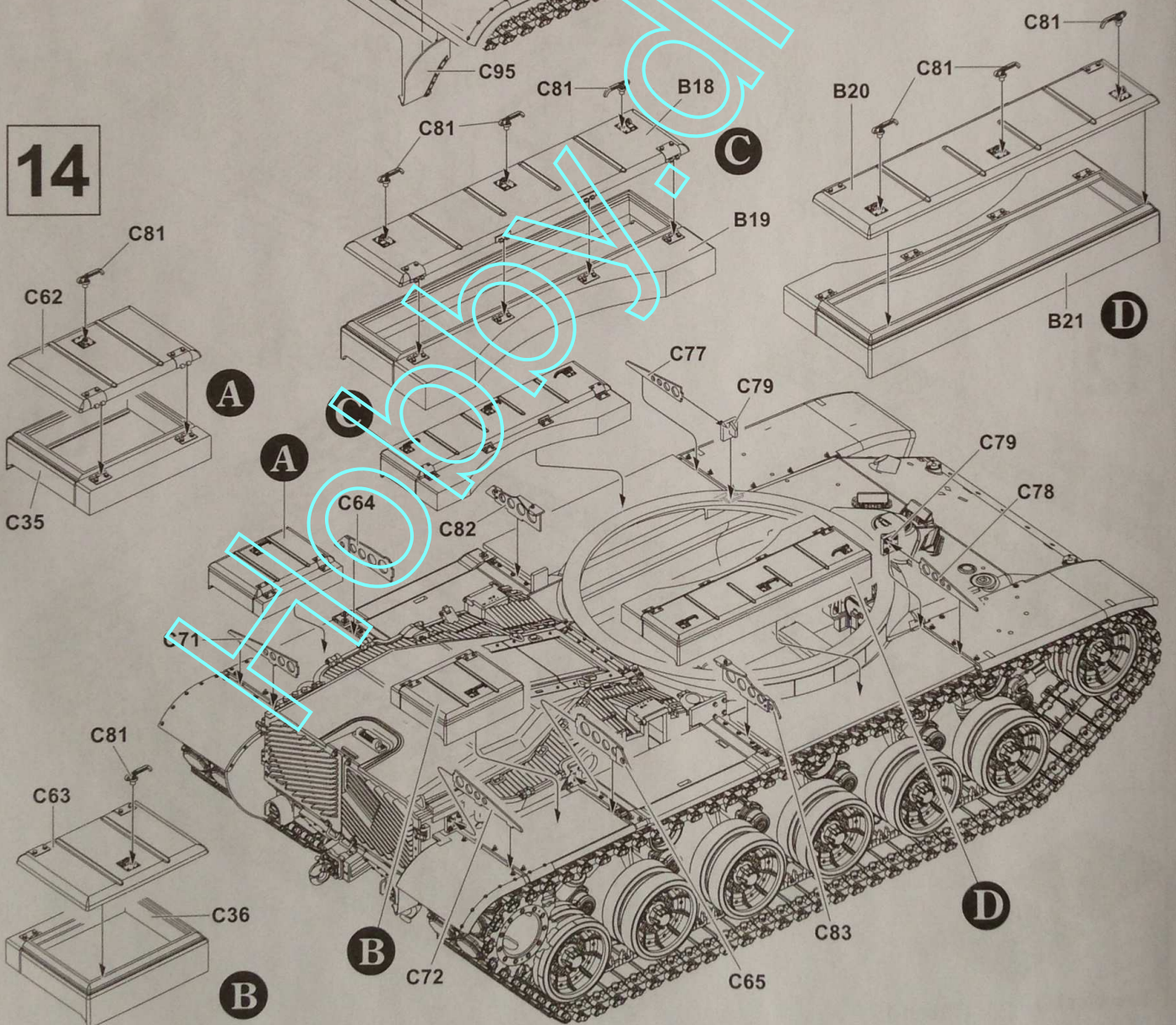



15

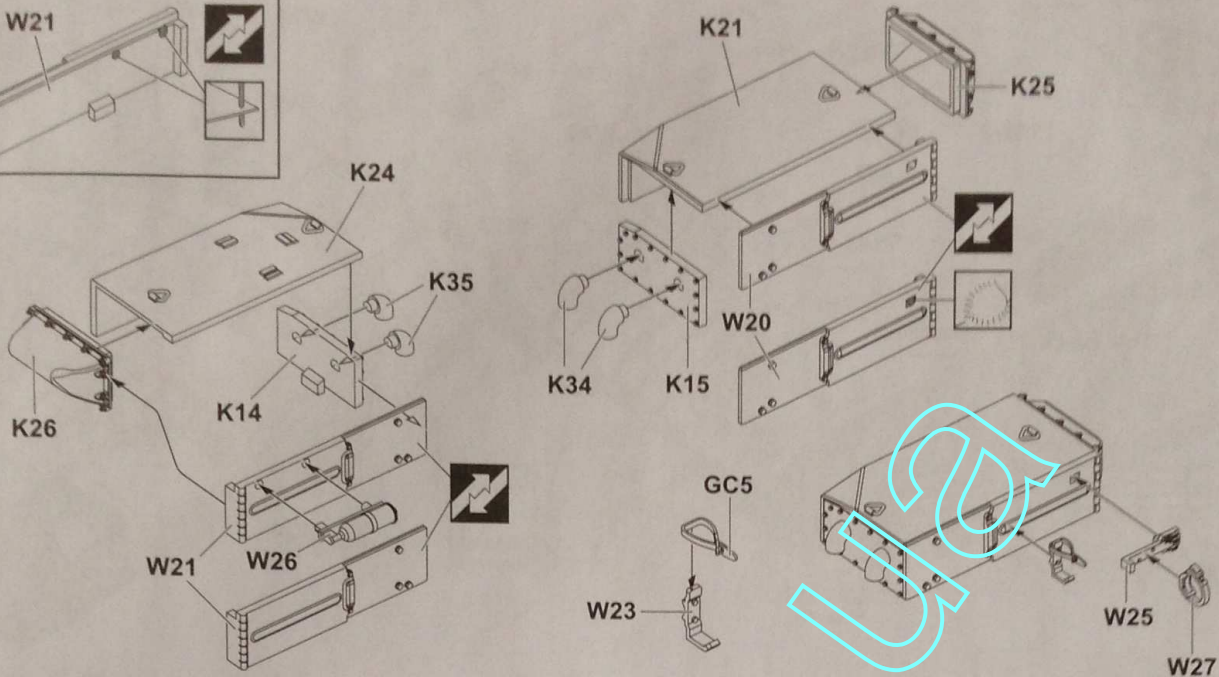
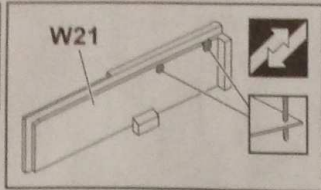

16

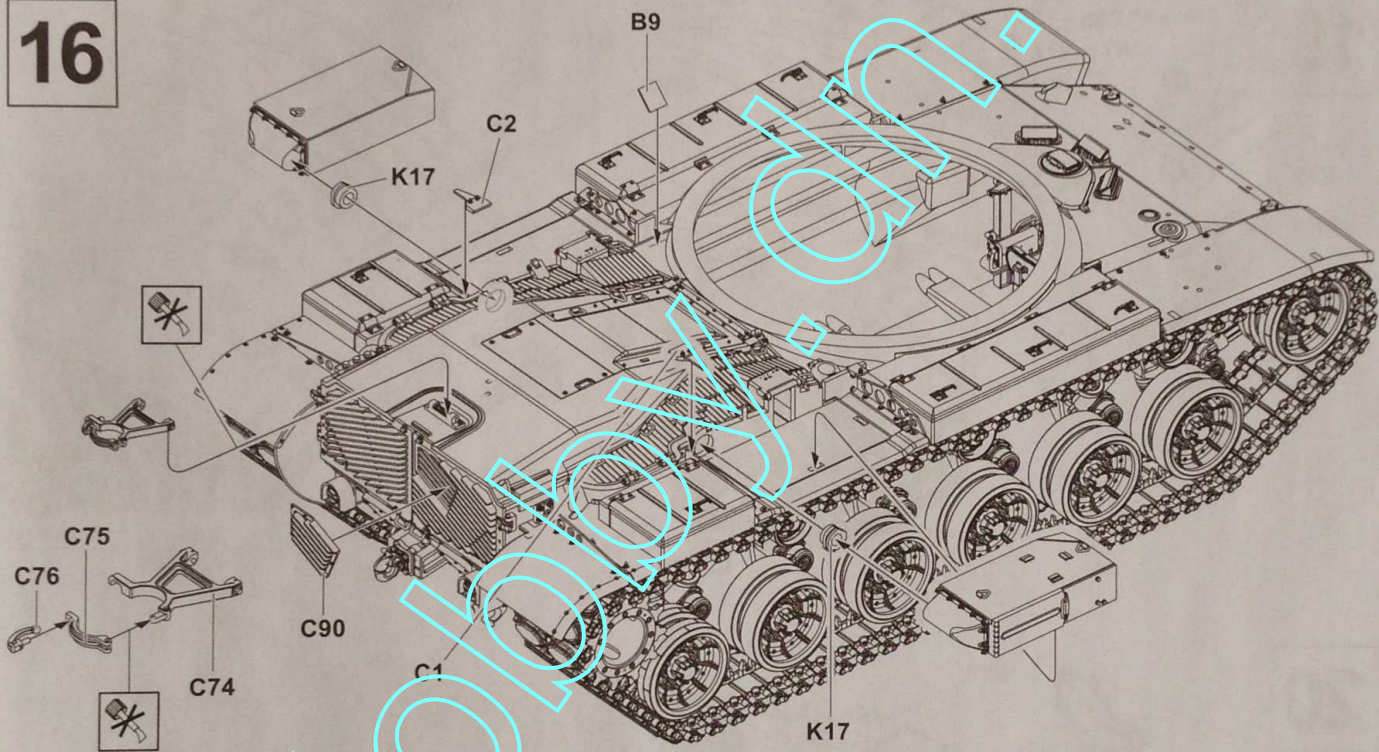

17

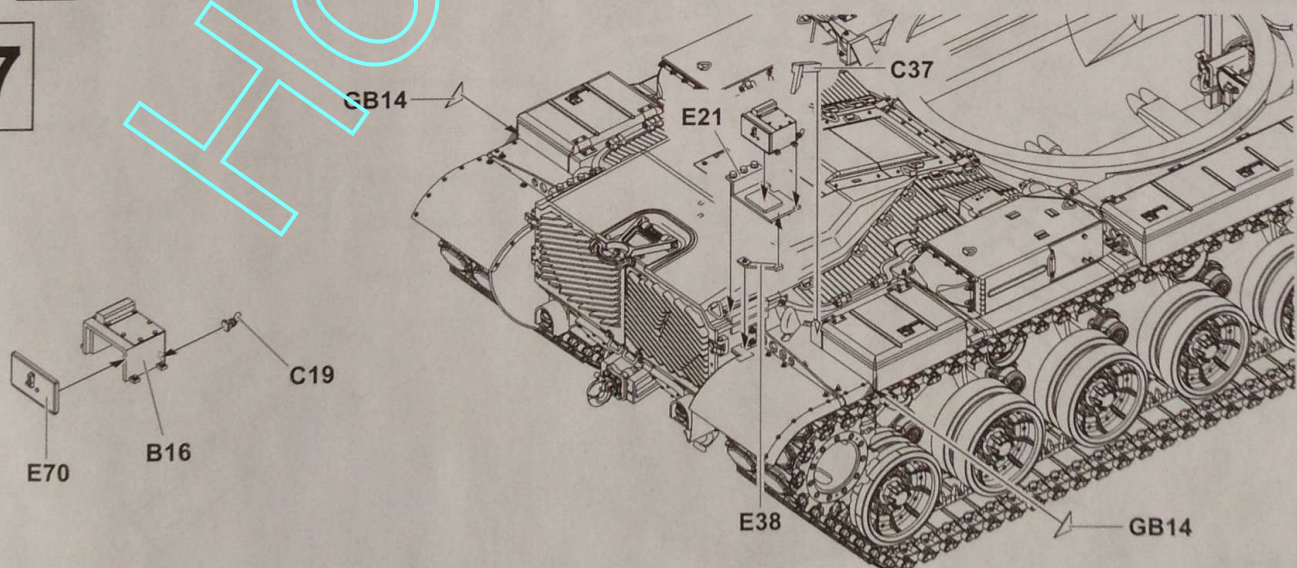



18

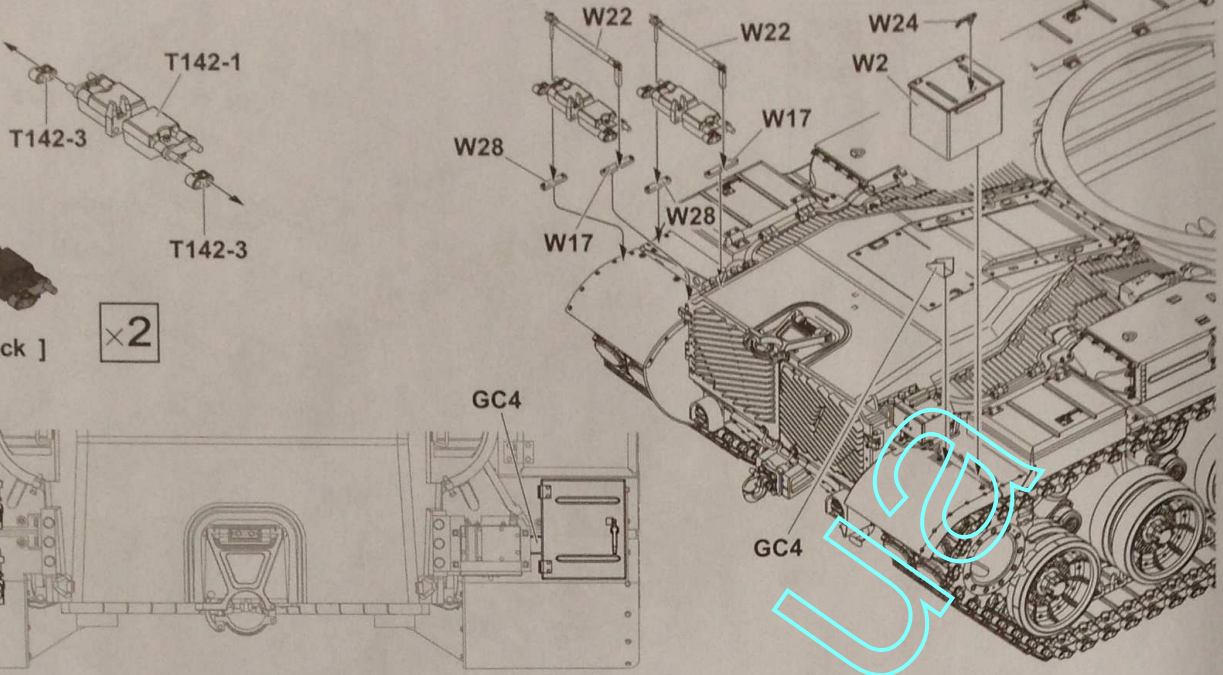

[ Steel ]  
 [ Tire black ]  
 ×2

19

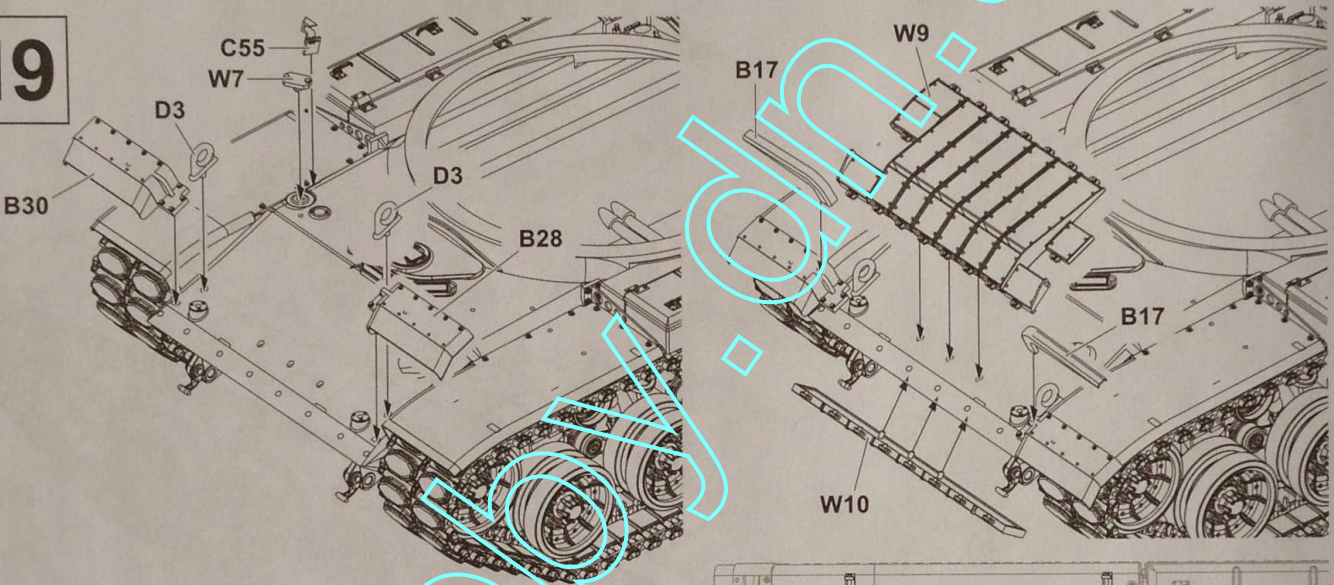

20

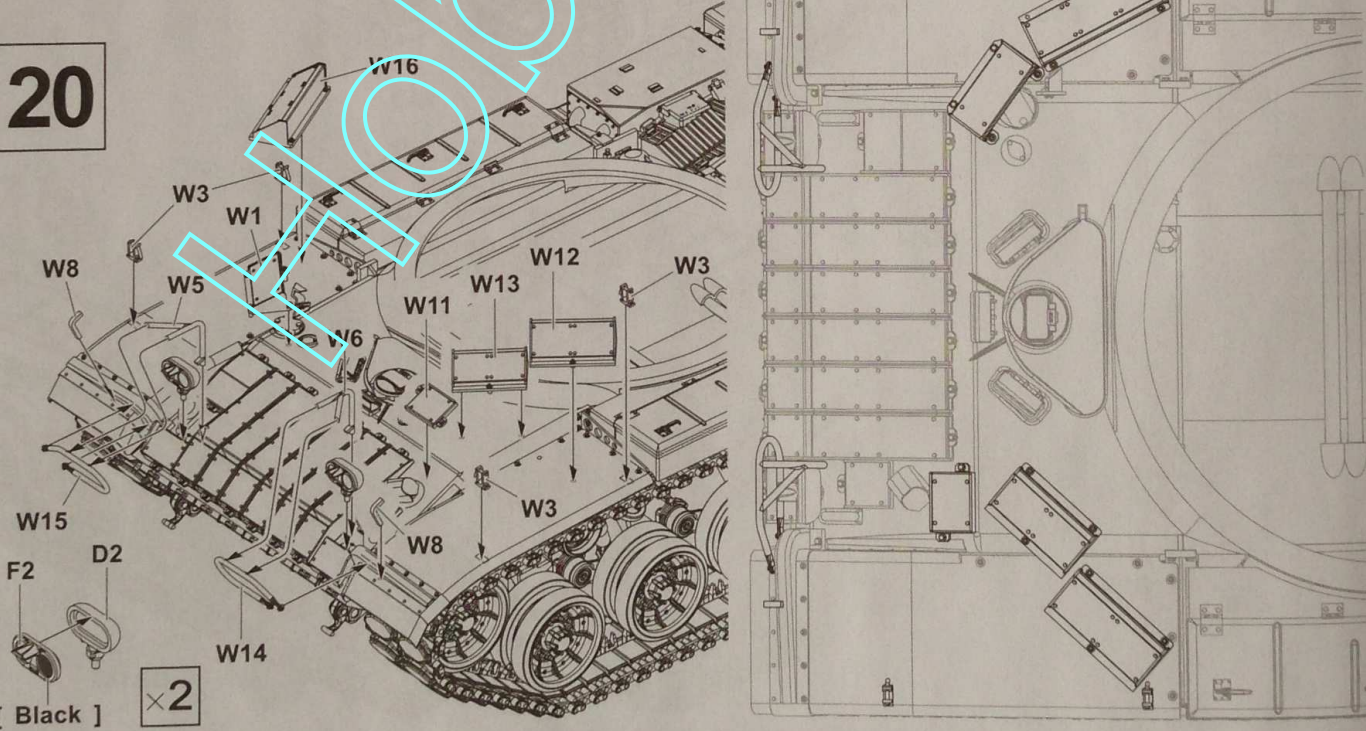

[ Black ]  
 ×2



21

Length : 8cm

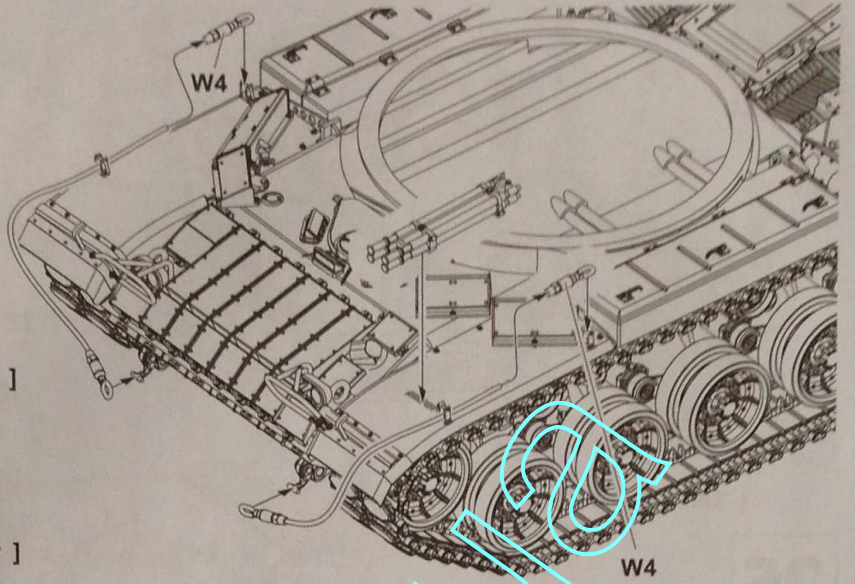
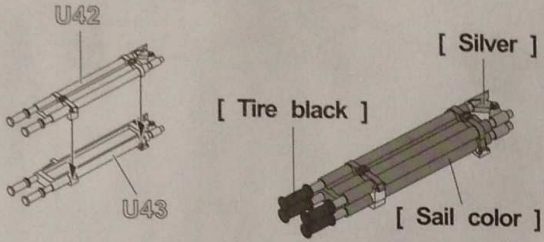
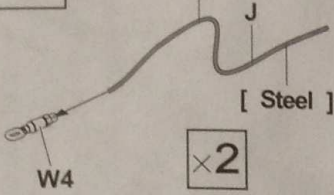

22

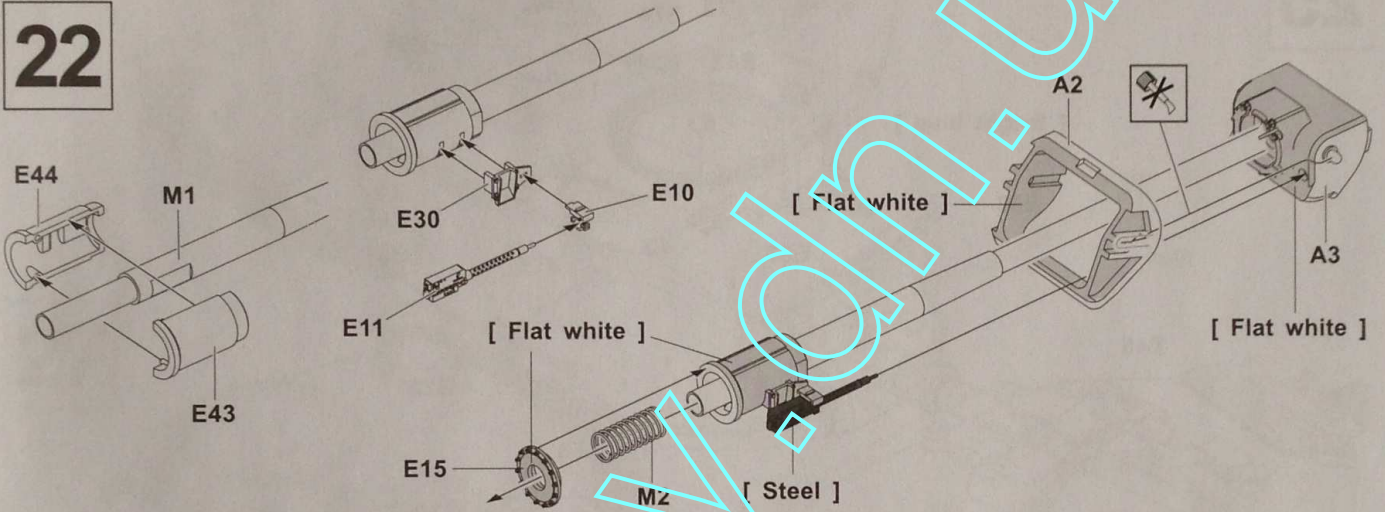

23

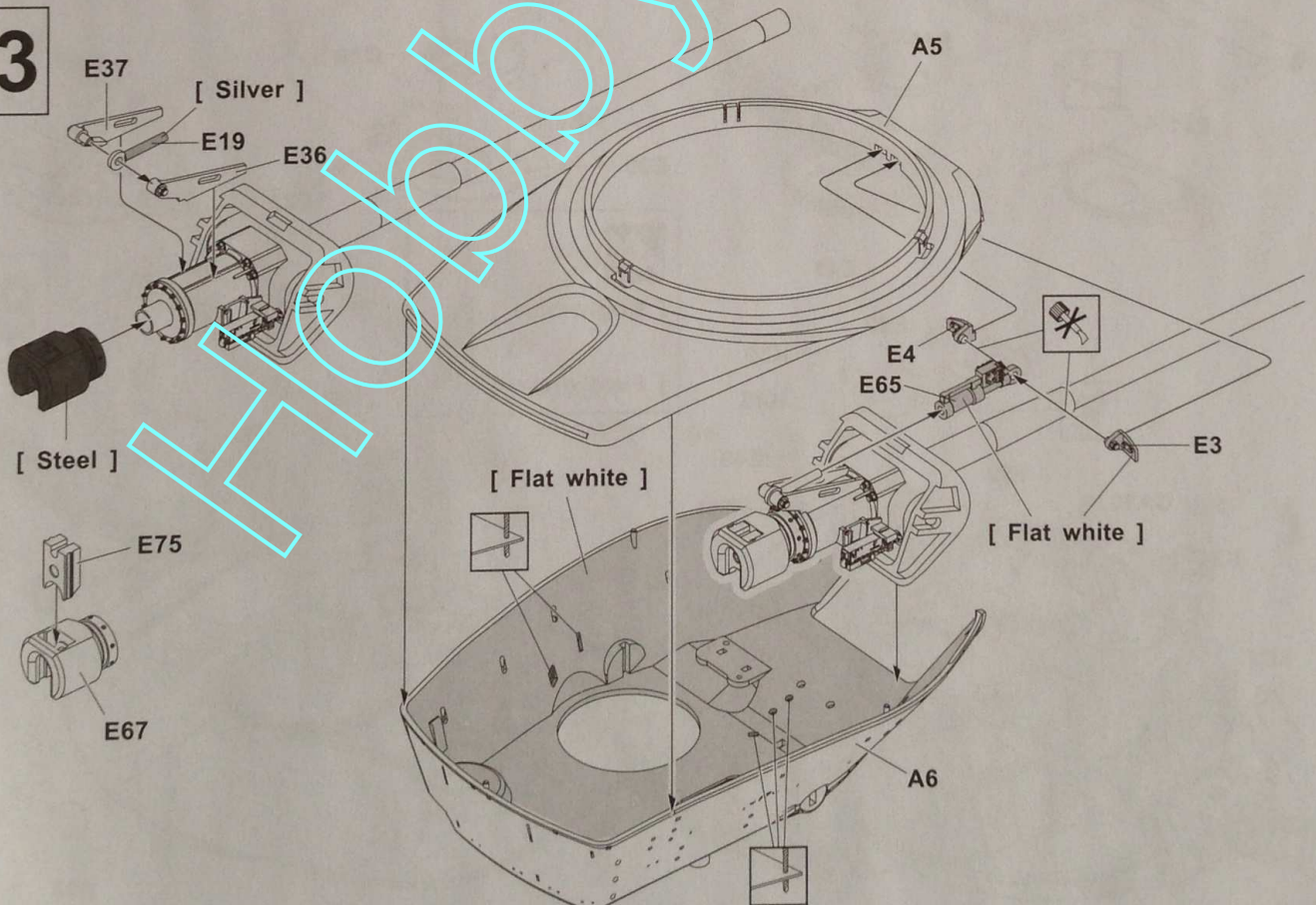



24

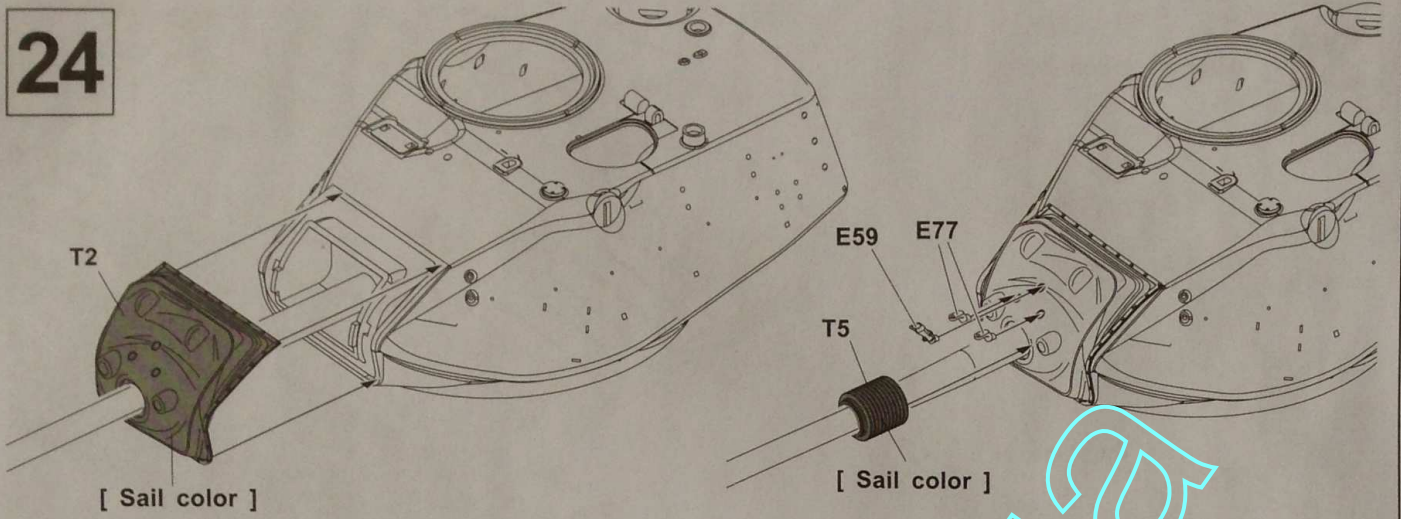

25

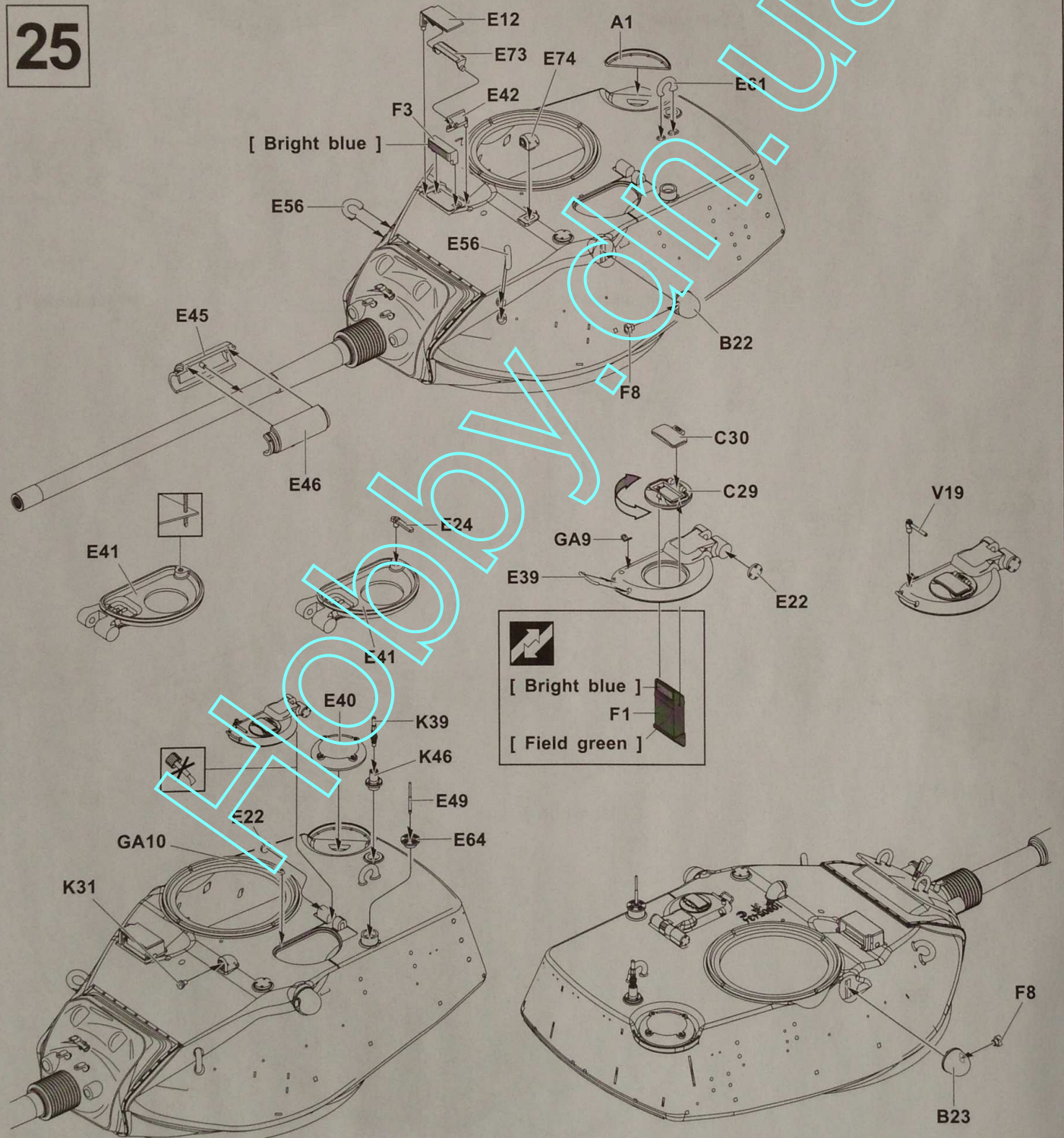



26

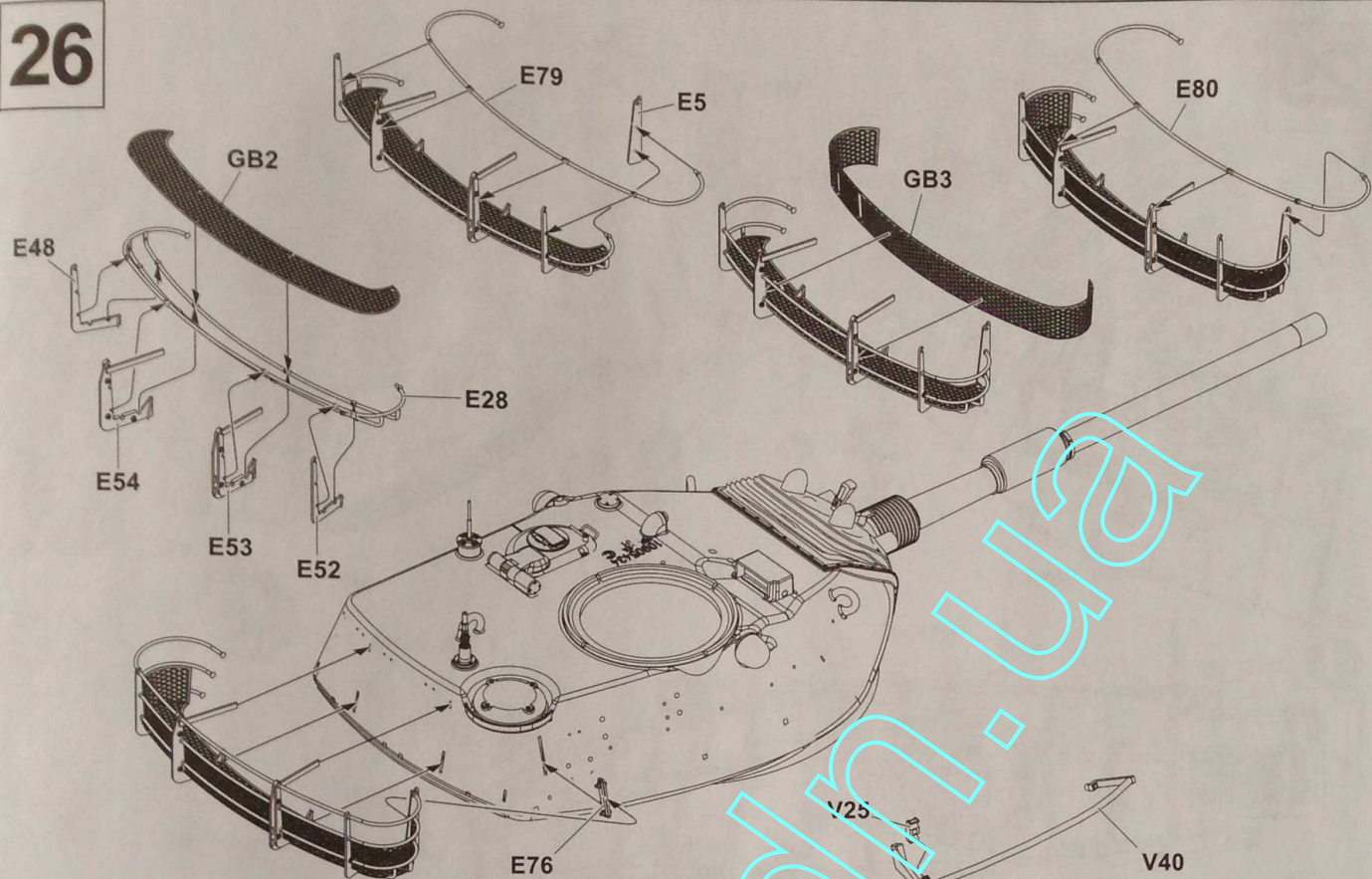

27

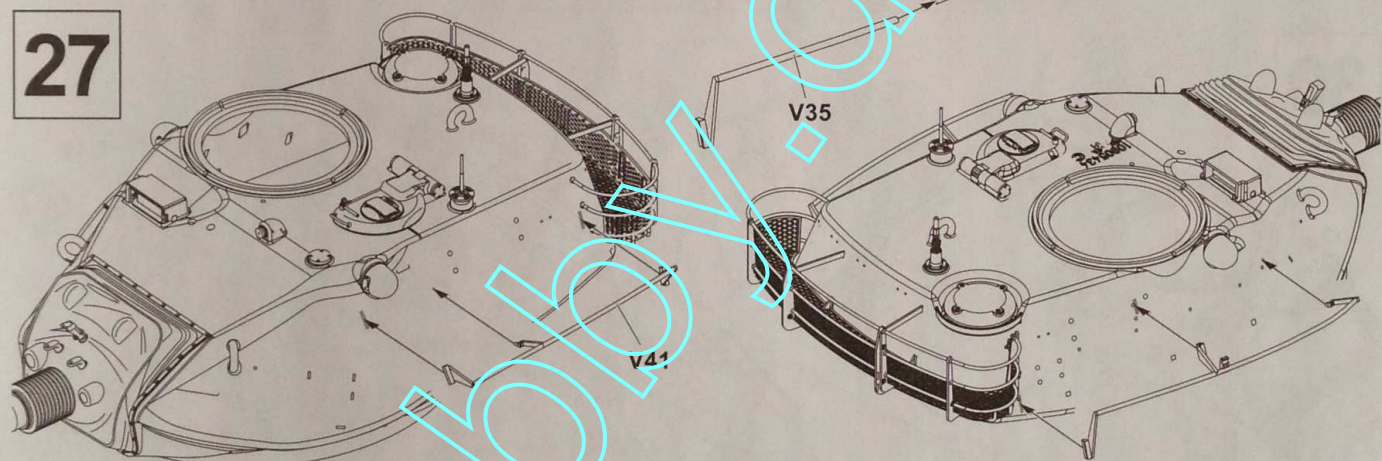

28

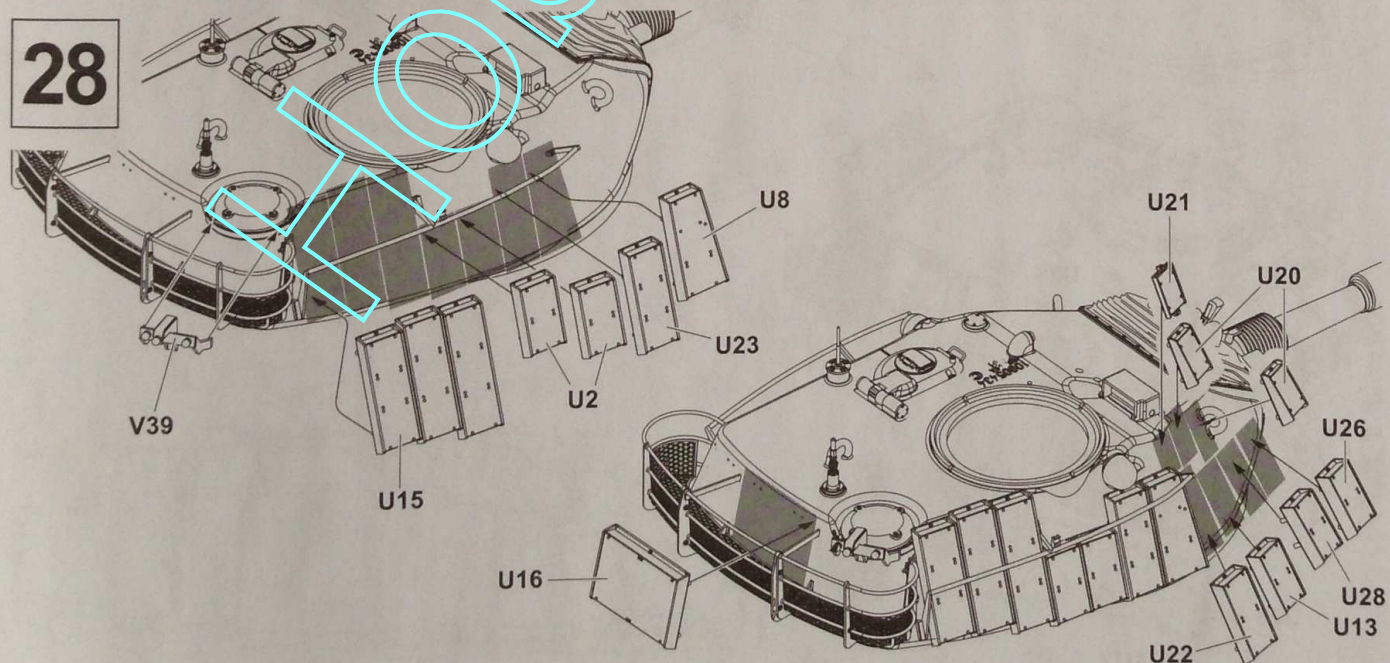



29

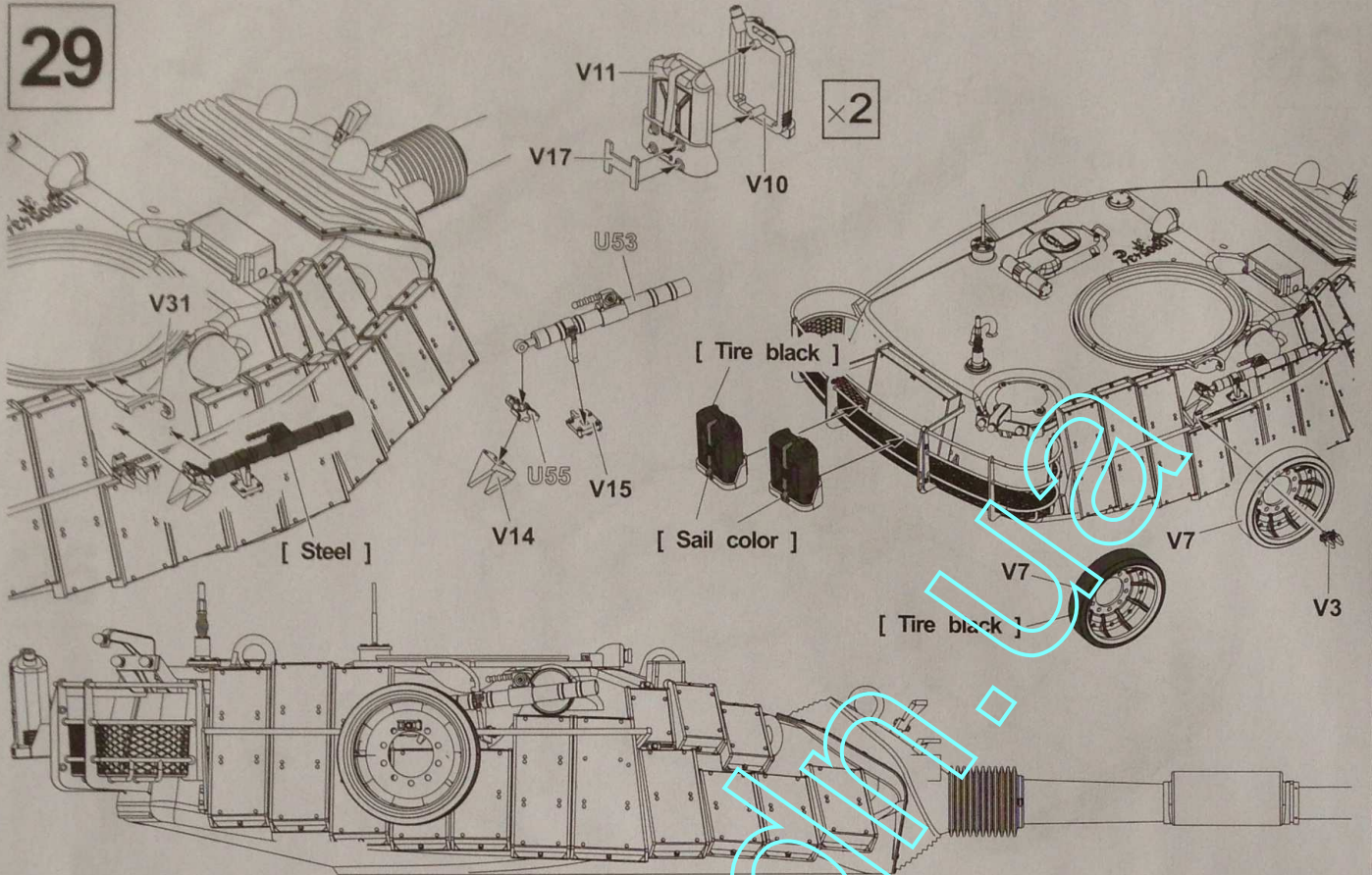

30

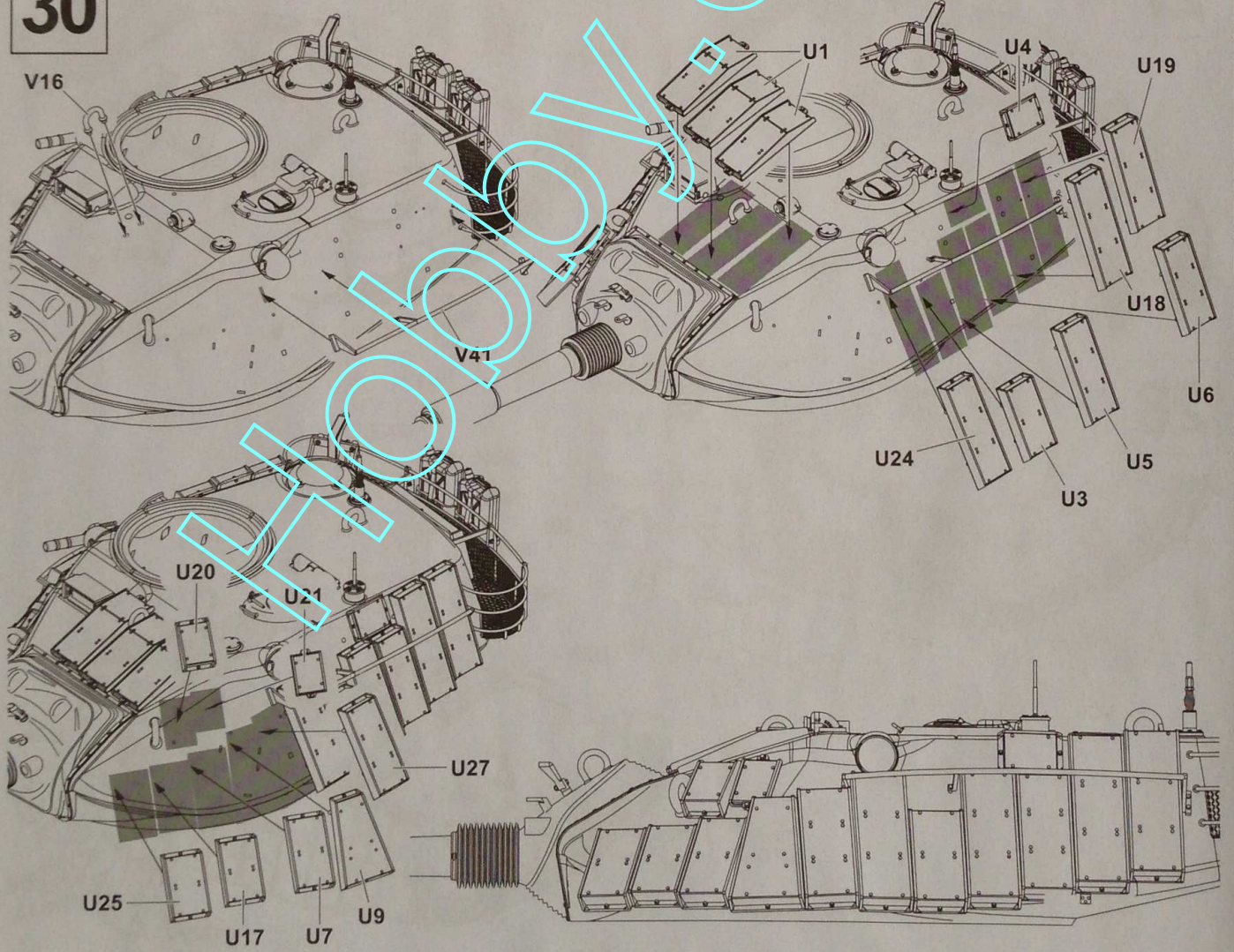



31

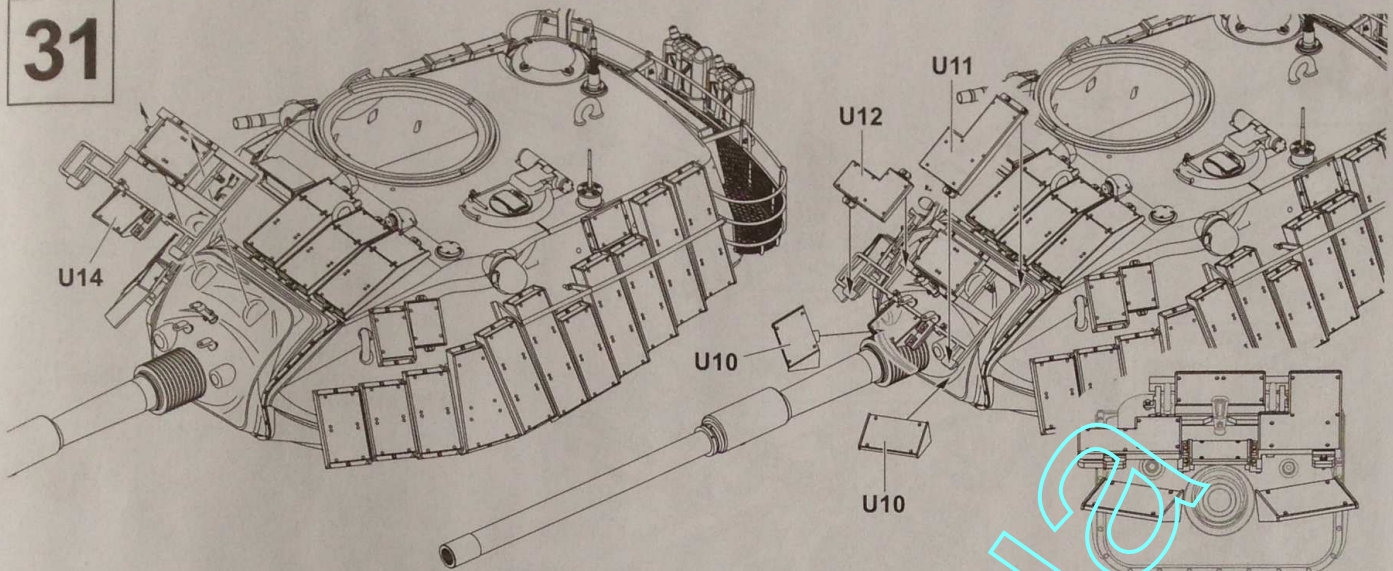

32

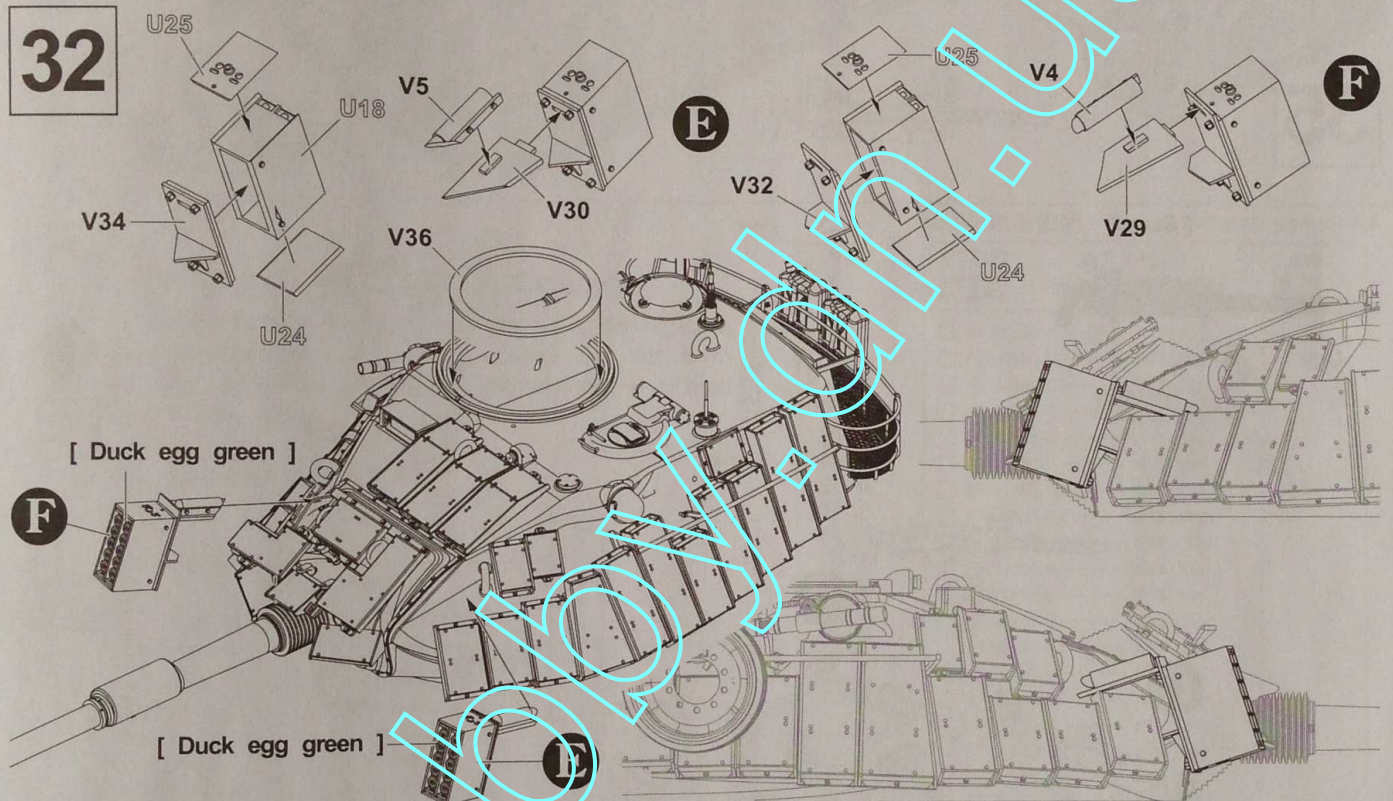

33

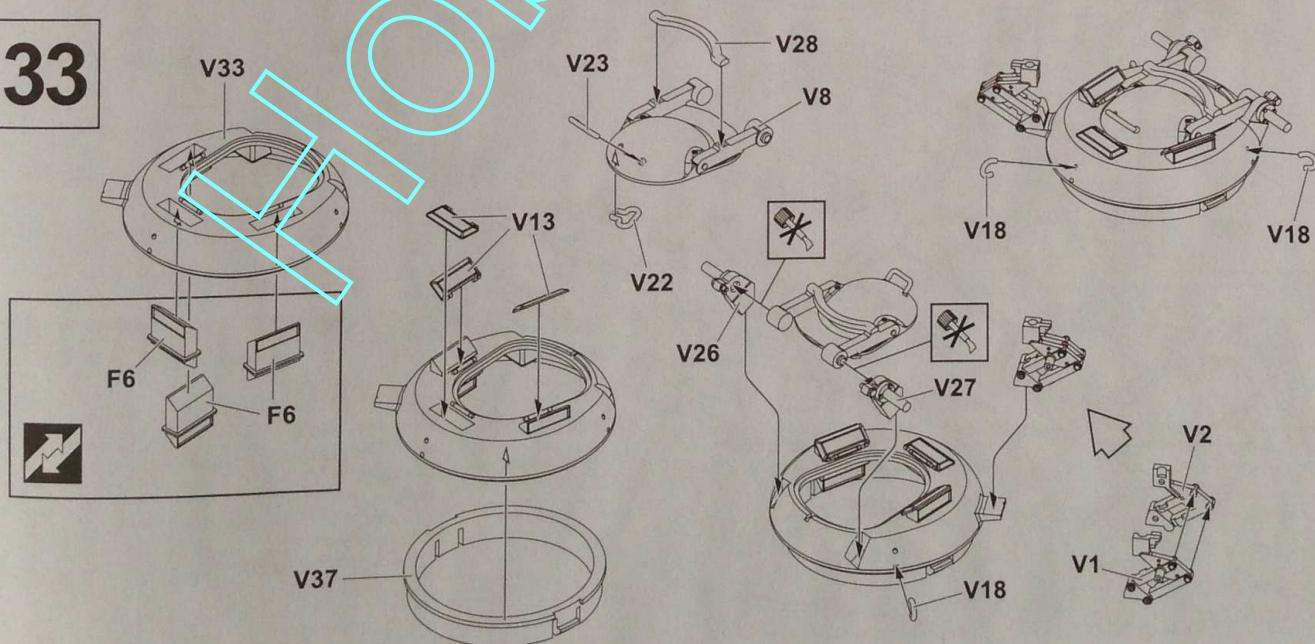



34

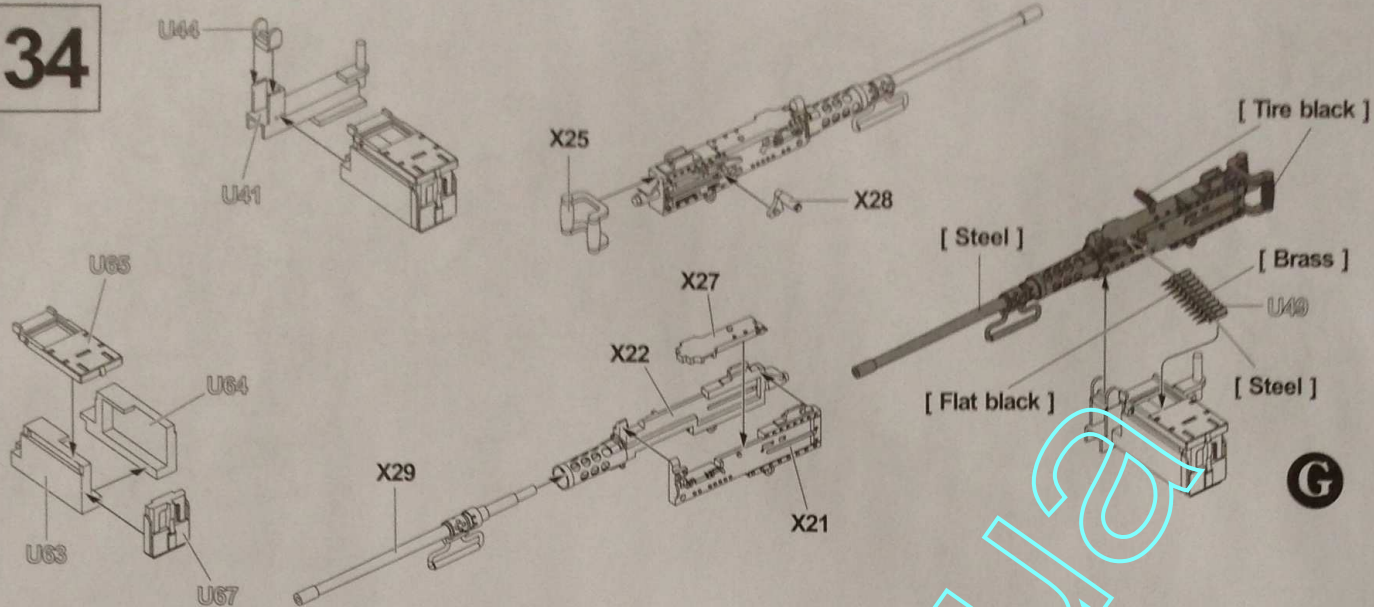

35

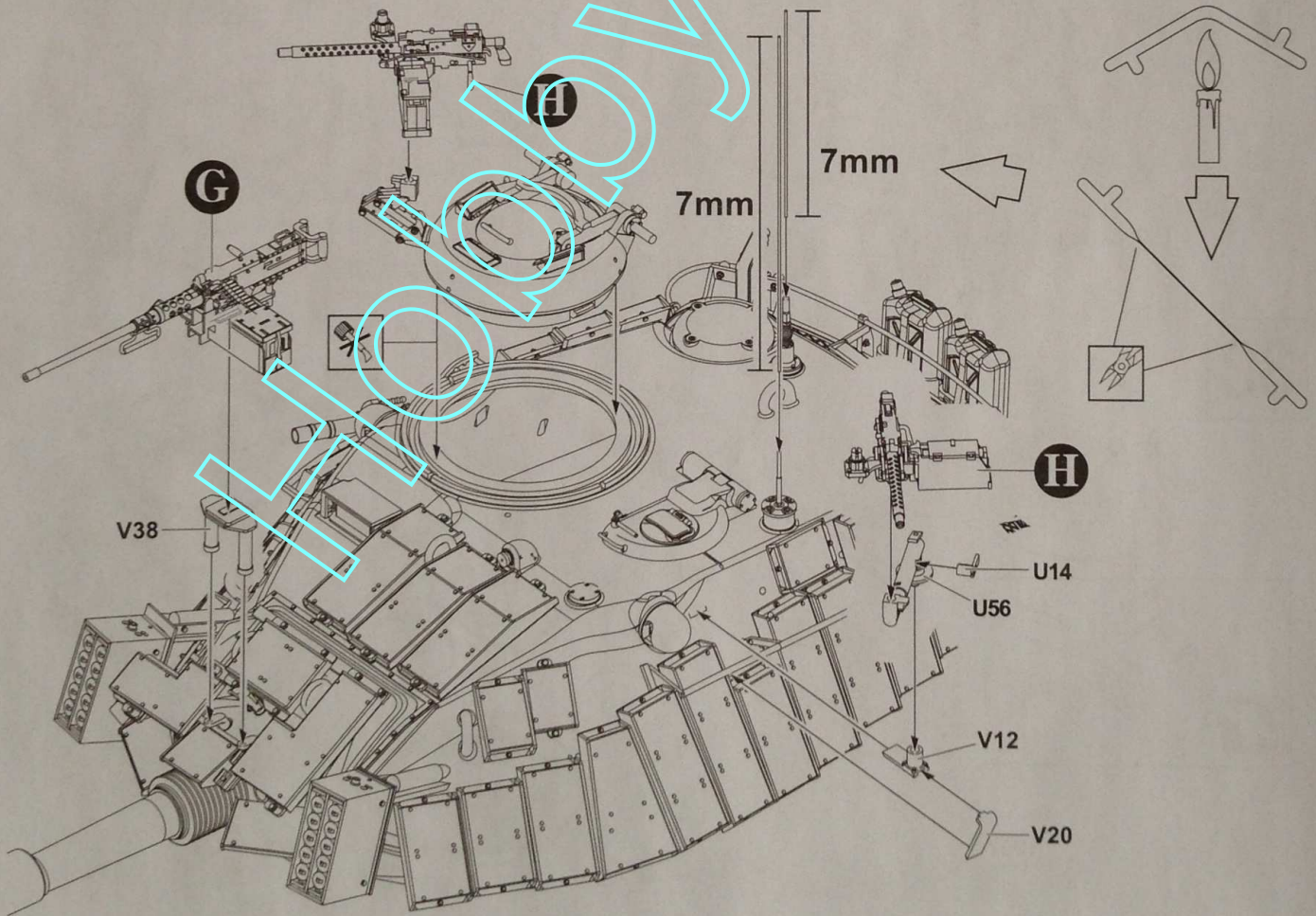
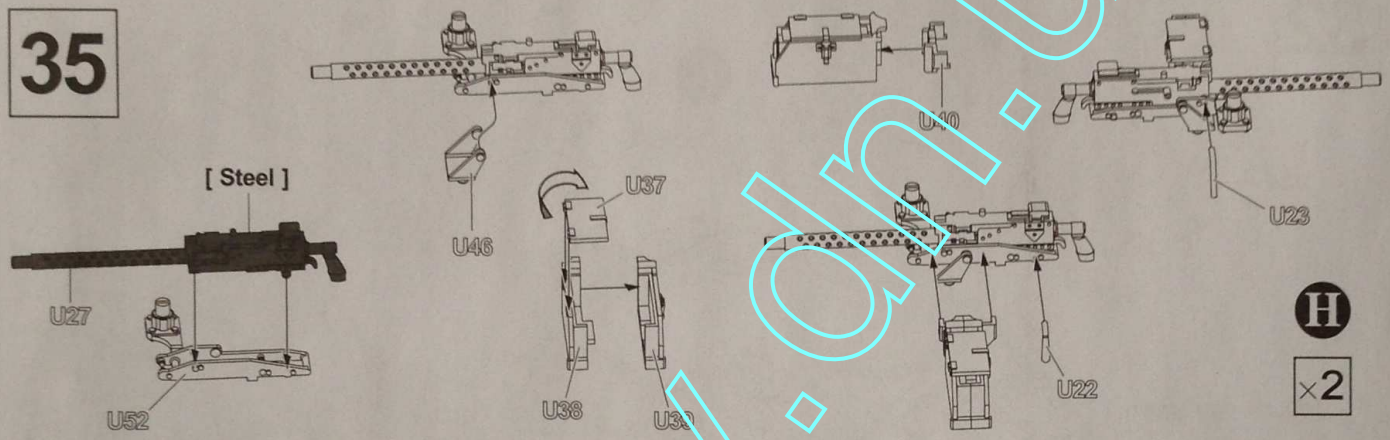



36

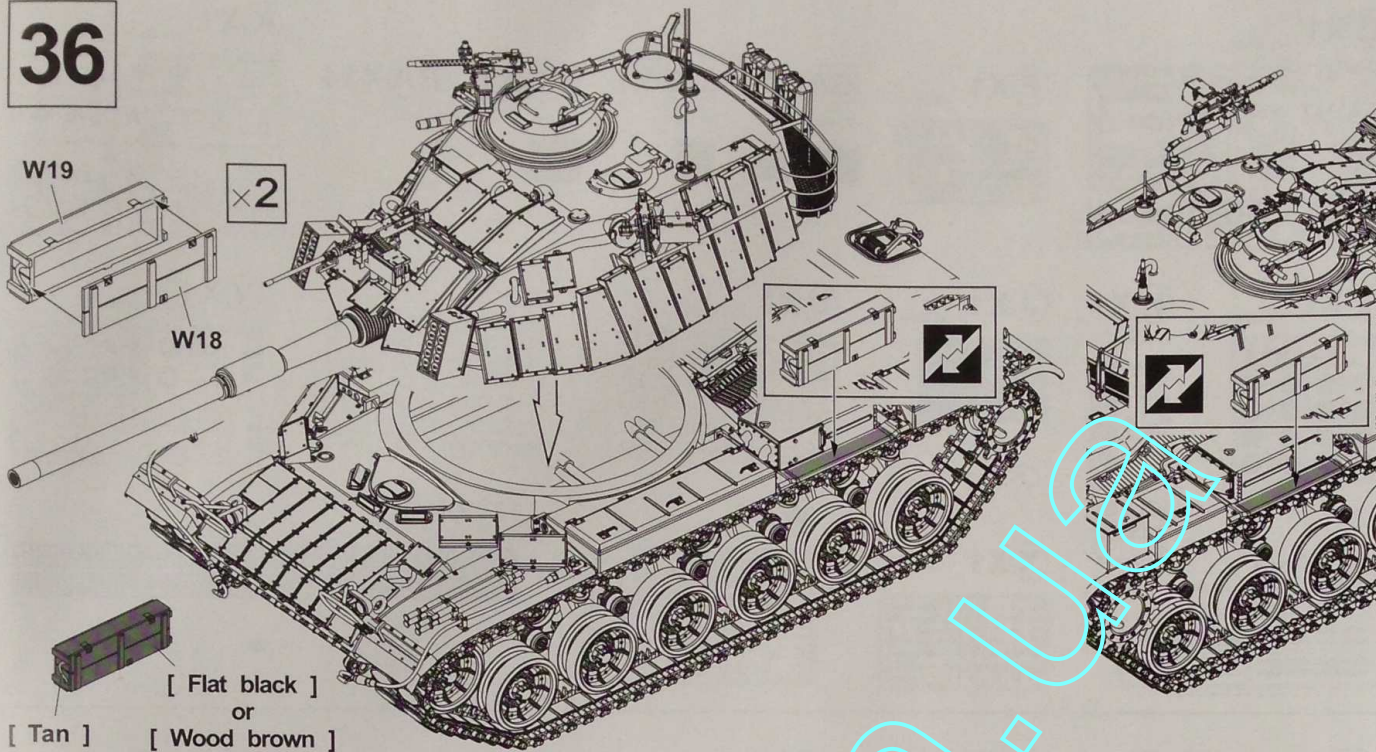

**Instructions:**

If for some reason, you are not fully satisfied or have questions concerning our product; Please use the form provide, and send it to our nearest representative or mail it directly to our office.

We will deal with that A.S.A.P.

限臺灣地區使用 For Taiwanese use only!



**AF 35309 零件補充申請表**

申請人  
姓 地 電  
名 址 話

- AF 35060-A ——— NT\$ 150
- AF 35060-B ——— NT\$ 250
- AF 35060-C ——— NT\$ 250
- AF 35060-D ——— NT\$ 300
- AF 35060-E ——— NT\$ 180
- AF 35060-F ——— NT\$ 150
- AF 35060-GA ——— NT\$ 120
- AF 35060-GB ——— NT\$ 180
- AF 35309-GC ——— NT\$ 160
- AF 35060-H ——— NT\$ 160
- AF 35060-I ——— NT\$ 180
- AF 35309-J ——— NT\$ 160
- AF 35060-K ——— NT\$ 180
- AF 35060-M ——— NT\$ 280
- AF 35060-RA ——— NT\$ 120
- AF 35309-T ——— NT\$ 490
- AF 35010-T142 ——— NT\$ 30
- AF 35246-X ——— NT\$ 180
- AF 35267-U ——— NT\$ 200
- AF 35309-U ——— NT\$ 160
- AF 35309-V ——— NT\$ 180
- AF 35309-W ——— NT\$ 170
- +郵寄費 ——— NT\$ 80

(請填)總計NT\$ \_\_\_\_\_

零件補充原因:(請於  打 )

原包裝即  遺失或  毀損,

製作途中  遺失或  毀損,

其他原因 \_\_\_\_\_

總代理戰鷹企業有限公司收本公司將儘速為您處理。  
請將本表與該部品相同金額之郵政匯票一同寄至



**AF 35309 Parts Replacement Form**

- AF 35060-A
- AF 35060-B
- AF 35060-C
- AF 35060-D
- AF 35060-E
- AF 35060-F
- AF 35060-GA
- AF 35060-GB
- AF 35309-GC
- AF 35060-H
- AF 35060-I
- AF 35309-J
- AF 35060-K
- AF 35060-M
- AF 35060-RA
- AF 35309-T
- AF 35010-T142
- AF 35246-X
- AF 35267-U
- AF 35309-U
- AF 35309-V
- AF 35309-W

Reason for replacement:  Missing  Broken

Signature: \_\_\_\_\_

**PARTS LIST 零件表**

**(M)X1**

AF 35060

M1 — M2

**(A)X1**

AF 35060

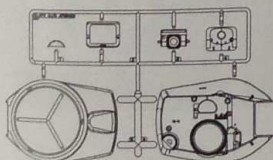

**(B)X1**

AF 35060

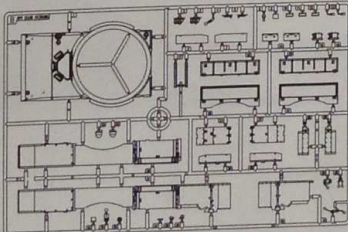

**(C)X1**

AF 35060

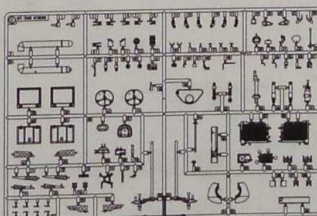

**(D)X2**

AF 35060

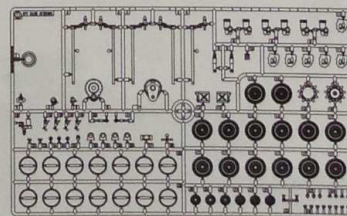



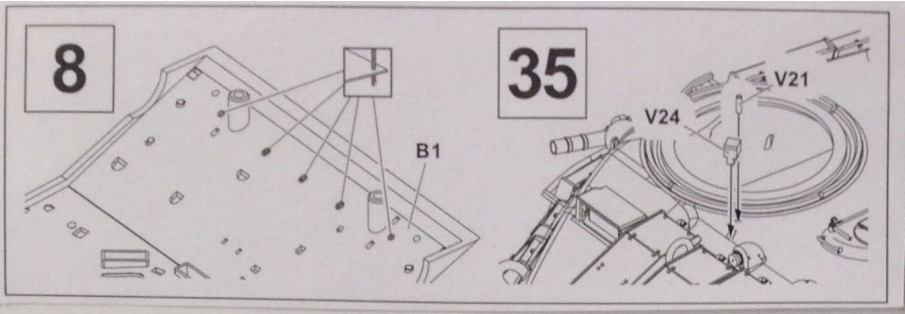

**E X1** AF 35060

**F X1** AF 35060

**G A X1** AF 35060

**G B X1** AF 35060

**G C X1** AF 35309

**R A X14** AF 35060

**K X1** AF 35060

**I X2** AF 35060

**H X1** AF 35060

**J X1** AF 35060

**U X1** AF 35309

**U X2** AF 35309

**V X1** AF 35309

**T142 X1** AF 35010

**X X1** AF 35246

**W X1** AF 35309

**T X1** AF 35309

T1 T2 T5 T6

Body Color: IDF Gray2 Flat black Sail color

**A**

**B**

**C**

**D**