

Revell®

KIT 5209

85520920200

TIGER SHARK P-40B

Although lacking somewhat in maneuverability and rate of climb, the P-40's top speed of 352 m.p.h. coupled with its rugged construction, armor plating and fast diving speed, enabled it to hold its own against most of the fighter planes in existence at that time.

Names for the P-40B ranged from the Curtiss "Hawk", in the United States, "Tomahawk" in Great Britain, to the "Tiger Shark" of the "Flying Tigers" in China.

The "Flying Tigers" of China were formed into three squadrons, the 1st (Adam and Eve), the 2nd (Panda Bears) and the 3rd (Hell's Angels). They fought their first action on Dec. 20, 1941 and in the following six and a half months compiled a record of 299 victories with a loss of only 50 planes, eight pilots killed and four missing.

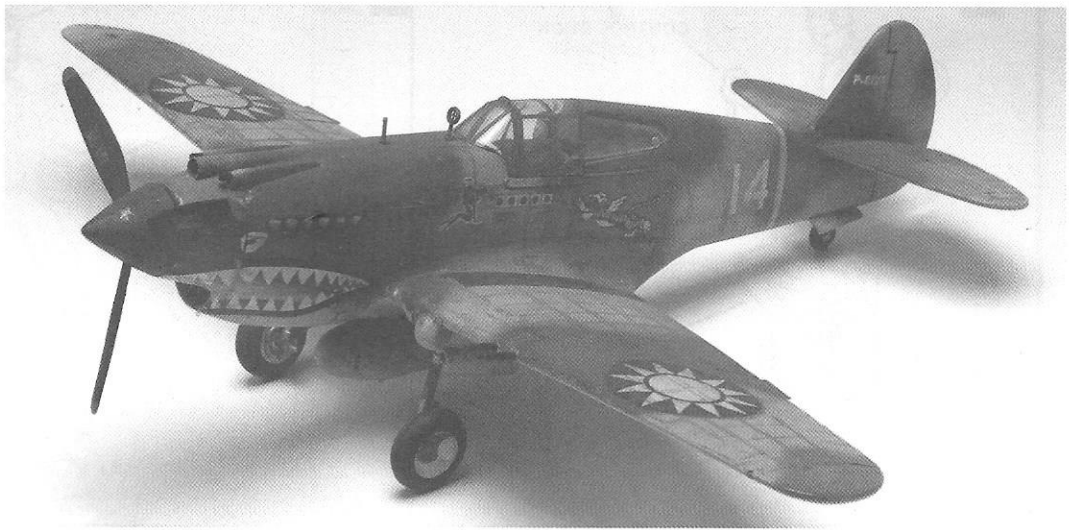

* REPEAT SEVERAL TIMES * REPEAT PROCEDURE * OPTIONAL PARTS * DECAL * ASSEMBLY CAUTION * CEMENT TOGETHER * REMOVE AND THROW AWAY * DO NOT CEMENT
 * A REPETER PLUSIEURS FOIS * RÈPÈTEZ LE PROCÈDE * PIÈCES EN OPTION * DECAL COMANIE * ATTENTION D'ASSEMBLÉE * A COLLER * A RETIRER ET JETER * NE PAS COLLER

READ THIS BEFORE YOU BEGIN

- * Study the assembly drawings.
- * Each plastic part is identified by a number.
- * In the assembly drawings, some parts will be marked by a star (★) to indicate chrome plated plastic.
- * For better paint and decal adhesion, wash the plastic parts in a mild detergent solution. Rinse and let air dry.
- * Check the fit of each piece before cementing in place.
- * Use only cement for polystyrene plastic.
- * Scrape plating and paint from areas to be cemented.
- * Allow paint to dry thoroughly before handling parts.
- * Any unused parts may be discarded.

DECAL APPLICATION INSTRUCTIONS

1. Cut desired decal from sheet.
2. Dip decal in water for a few seconds.
3. Place wet decal on paper towel.
4. Wait until decal is movable on paper backing.
5. Place decal in position on model, face up and slide backing away.
6. Press out air bubbles with a soft damp cloth.
7. Milkyness that may appear is for better decal adhesion and will dry clear. Wipe away any excess adhesive.
8. Do not touch decal until fully dry.
9. Allow the decals 48 hours to dry before applying clear coat.

NOTE: Decals are compatible with setting solutions or solvents.

LIRE CE QUI SUIT AVANT DE COMMENCER

- * Etudier les schémas de montage.
- * Chaque pièce en plastique est identifiée par un numéro.
- * Sur les schémas de montage, certaines pièces sont marquées d'une étoile (★) pour indiquer qu'elles sont en plastique chromé.
- * Pour une meilleure prise de la peinture et des autocollants, laver les pièces en plastique avec une solution détergente peu concentrée. Les rincer et les laisser sécher à l'air.
- * Vérifier que chaque pièce s'ajuste bien avant de la coller en place.
- * N'utiliser que de la colle pour polystyrène.
- * Gratter les parties à coller pour enlever le chrome et la peinture.
- * Laisser la peinture bien sécher avant de manipuler les pièces.
- * Toute pièce inutilisée peut être jetée.

DIRECTIVES D'APPLICATION DES AUTOCOLLANTS

1. Découper l'autocollant désiré de la feuille.
2. Tremper l'autocollant dans de l'eau pendant quelques secondes.
3. Placer l'autocollant mouillé sur une serviette en papier.
4. Attendez que l'autocollant puisse être déplacé sur son support en papier.
5. Mettre l'autocollant en position sur le modèle face sur le dessus et faire glisser le support pour l'enlever.
6. Appuyer avec un chiffon doux humide pour éliminer les bulles d'air.
7. La substance laiteuse qui peut apparaître est destinée à améliorer l'adhésion de l'autocollant et devient incolore au séchage. Essuyer pour enlever tout excédent d'adhésif.
8. Ne pas toucher l'autocollant tant qu'il n'est pas bien sec.
9. Laisser l'autocollant sécher pendant 48 heures avant d'appliquer une couche transparente.

REMARQUE: Les autocollants sont compatibles avec les solutions de fixation ou les solvants.

This paint guide is provided to complete this kit as shown on the box.

Ce guide de peintures est fourni pour reproduire le modèle réduit qui apparaît sur la boîte.

Aluminum	Aluminum
Flat Black	Noir mat
Dark Earth	Terre foncée
Gray	Gris
Light Brown	Brun clair
Olive Drab	Gris vert
Red	Rouge
Sky Blue	Bleu ciel
Tan	Havane
Yellow	Jaune
Zinc Chromate (Interior Green)	Chromate de zinc

If you have any questions or comments, call our hotline at: **(800) 833-3570**
 or, please write to:

Revell Inc Consumer Service Department, 1850 Howard Street Unit A, Elk Grove Village, Illinois 60007

Be sure to include the plan number (85520920200), part number, description, your return address and phone number.

Visit our website: www.revell.com

1

COCKPIT ASSEMBLY

A

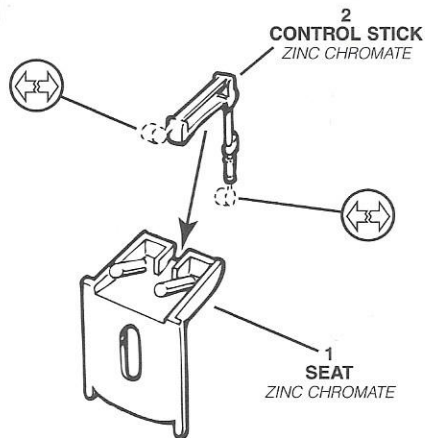

B

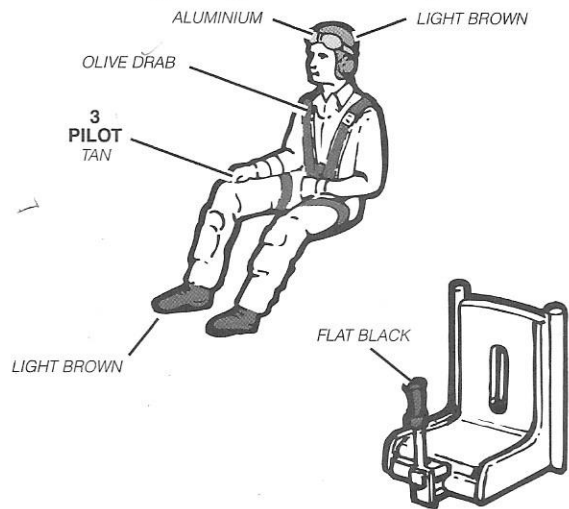

C

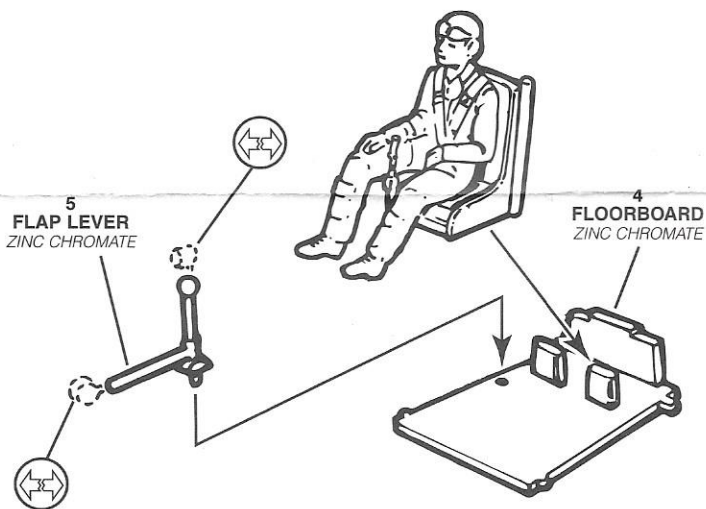

D

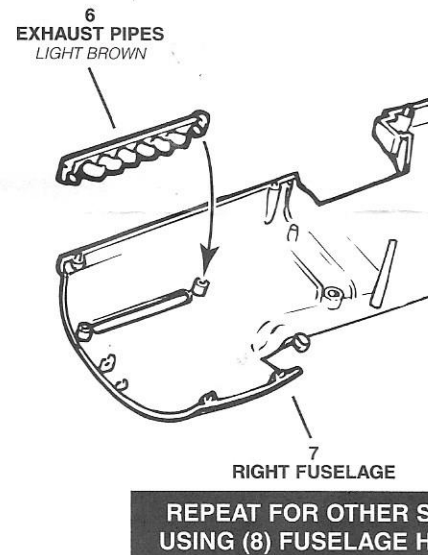

E

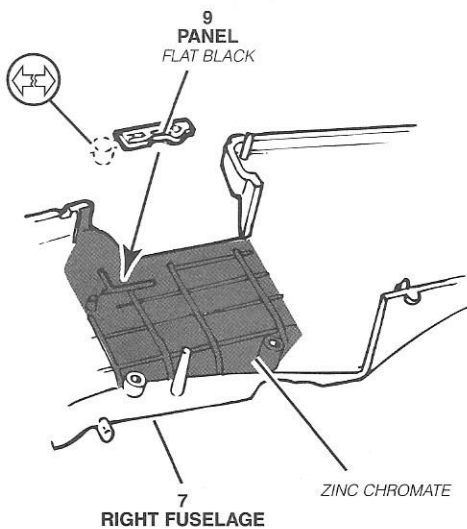

F

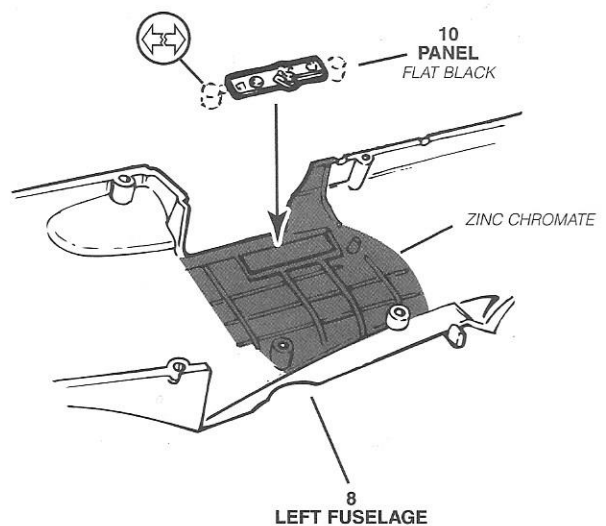

1

COCKPIT ASSEMBLY CONTINUED

G

11
INSTRUMENT PANEL
FLAT BLACK
WITH SILVER DETAILS

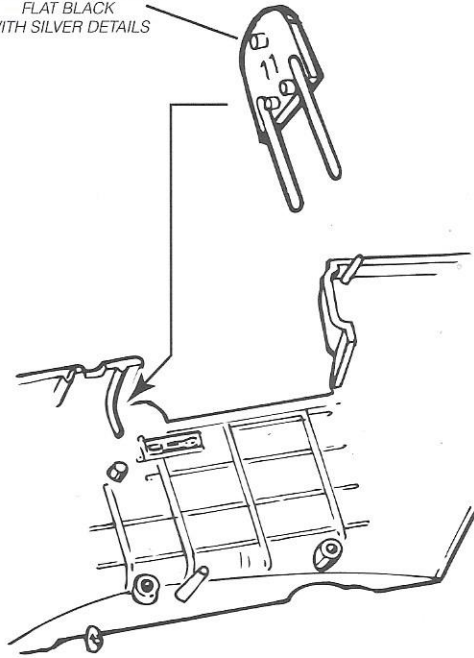

H

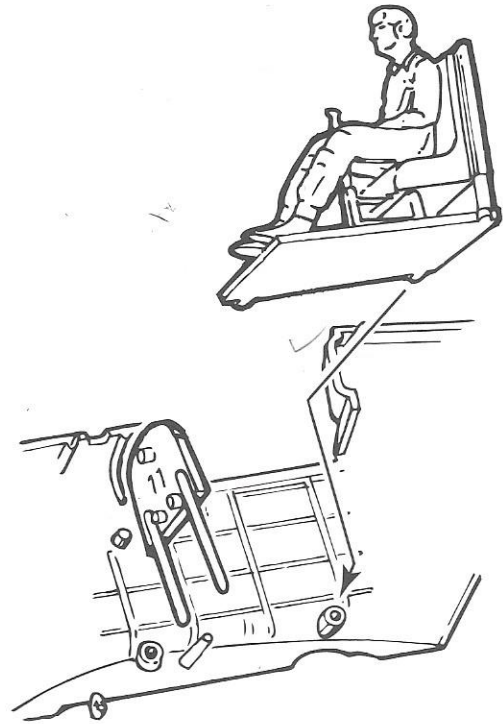

2

FUSELAGE ASSEMBLY

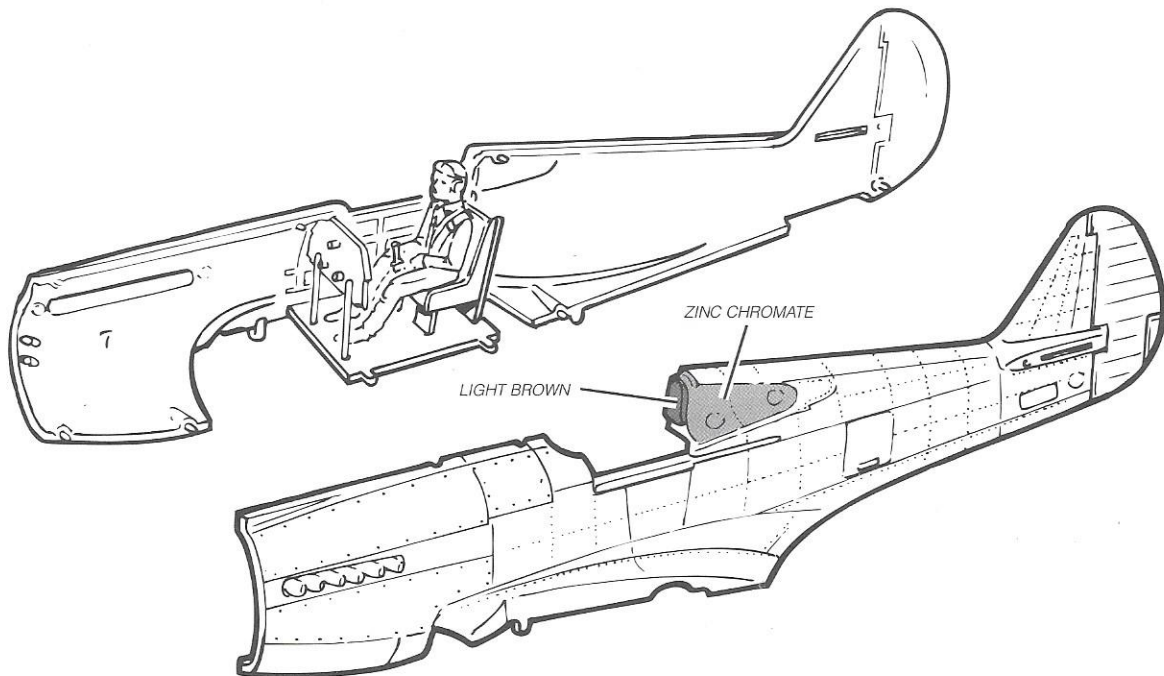

3

NOSE/TAIL ASSEMBLY

A

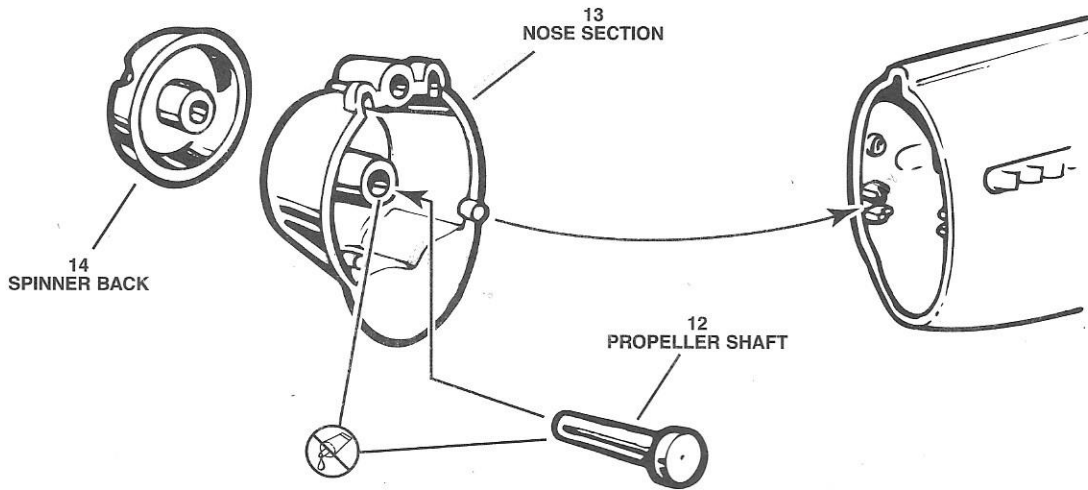

B

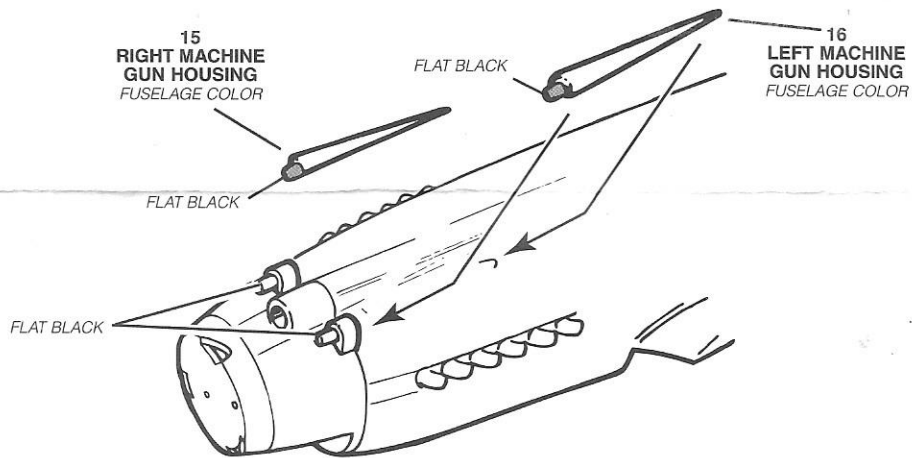

C

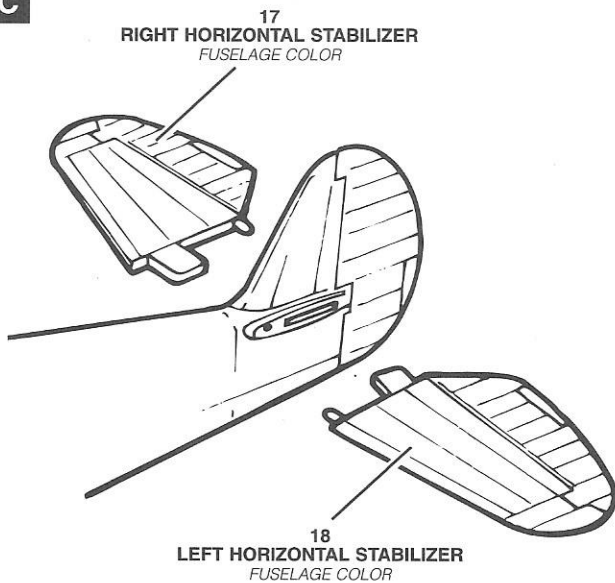

D

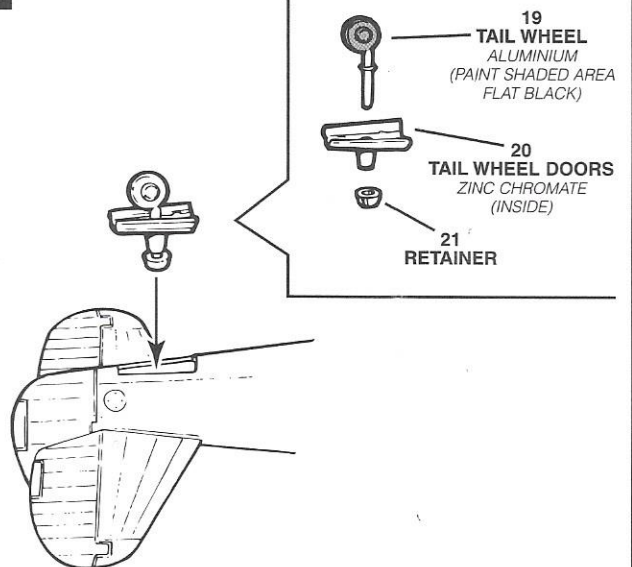

4

WING ASSEMBLY

A

29
LEFT PIVOT
RETAINER

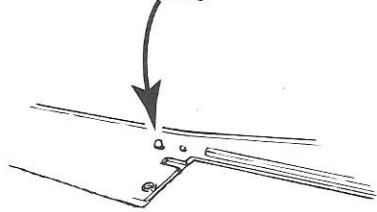

30
RIGHT PIVOT
RETAINER

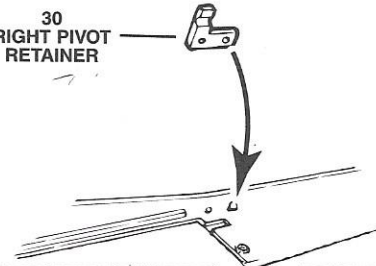

32
PITOT TUBE
ALUMINIUM

31
WING BOTTOM

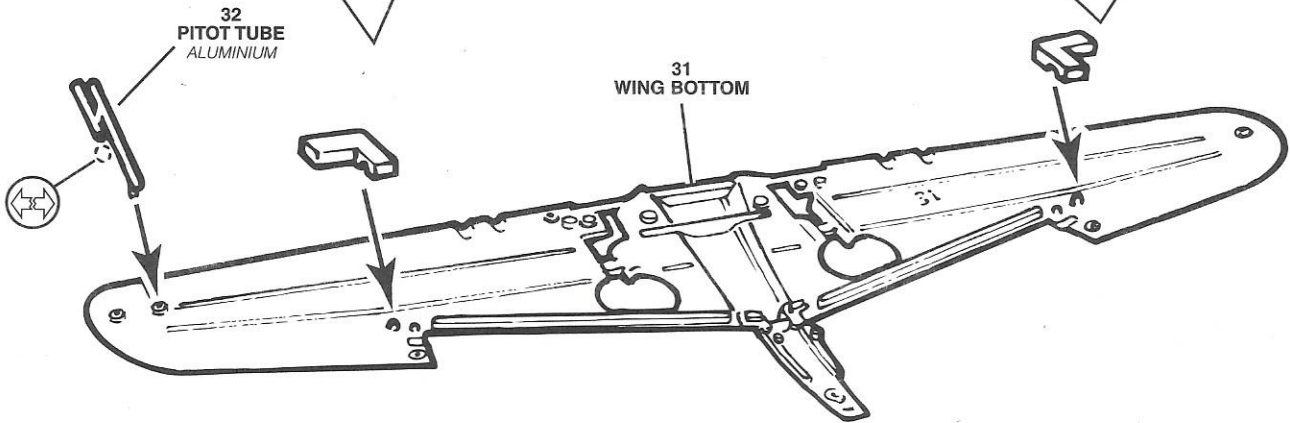

B

33
LEFT WING TOP

FLAT BLACK

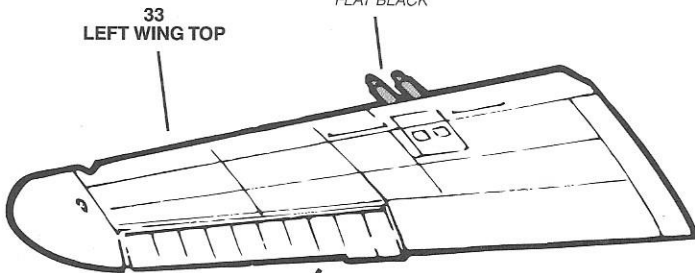

34
RIGHT WING TOP

FLAT BLACK

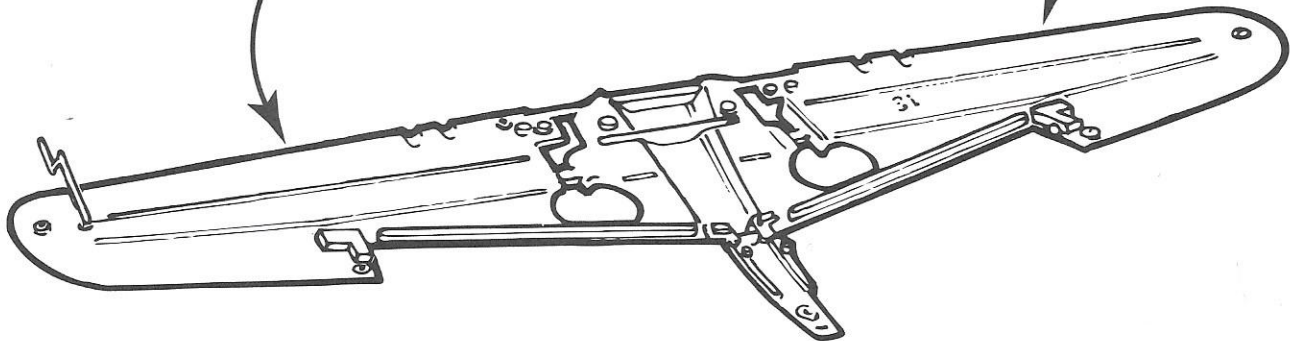
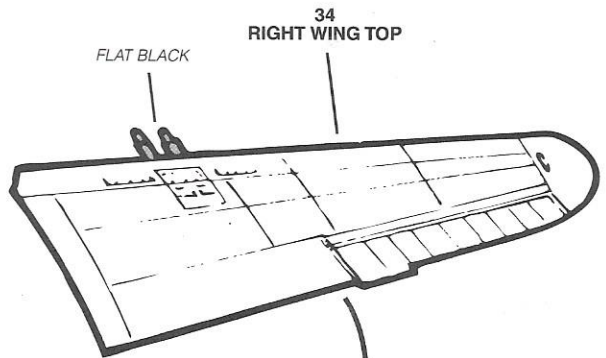

5

WING FLAP ASSEMBLY

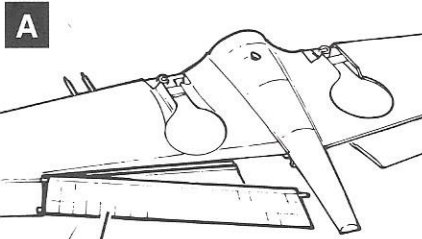

35
RIGHT WING FLAP

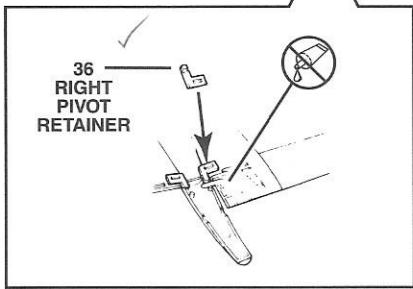

36
RIGHT
PIVOT
RETAINER

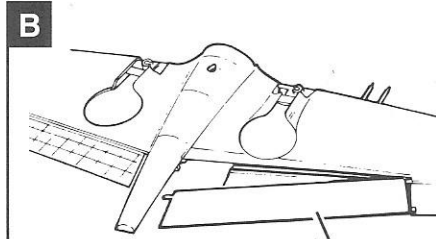

37
LEFT WING FLAP

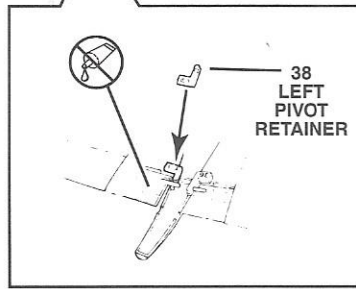

38
LEFT
PIVOT
RETAINER

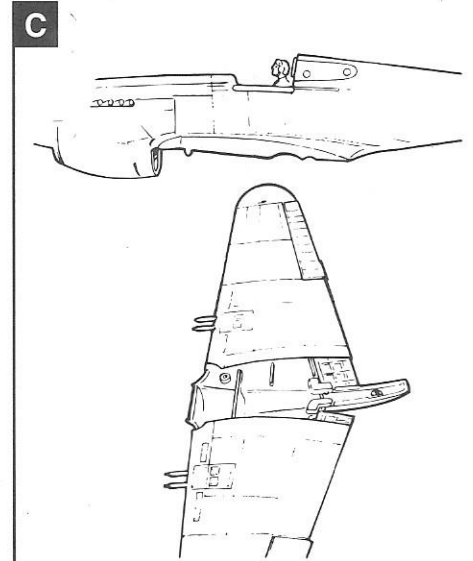

6

LANDING GEAR ASSEMBLY

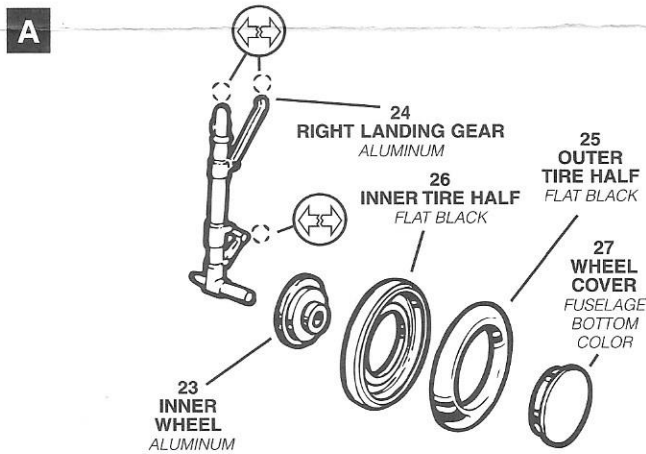

24
RIGHT LANDING GEAR
ALUMINUM

26
INNER TIRE HALF
FLAT BLACK

25
OUTER
TIRE HALF
FLAT BLACK

27
WHEEL
COVER
FUSELAGE
BOTTOM
COLOR

23
INNER
WHEEL
ALUMINUM

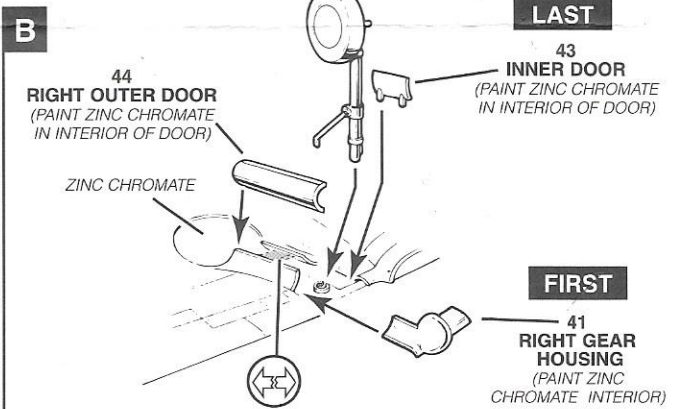

LAST

44
RIGHT OUTER DOOR
(PAINT ZINC CHROMATE
IN INTERIOR OF DOOR)

43
INNER DOOR
(PAINT ZINC CHROMATE
IN INTERIOR OF DOOR)

FIRST

41
RIGHT GEAR
HOUSING
(PAINT ZINC
CHROMATE INTERIOR)

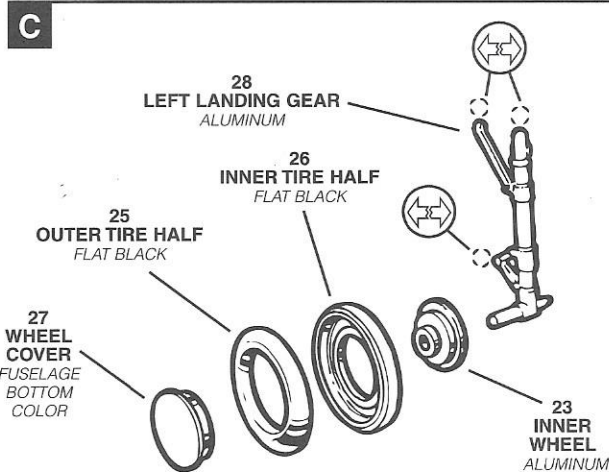

28
LEFT LANDING GEAR
ALUMINUM

26
INNER TIRE HALF
FLAT BLACK

25
OUTER TIRE HALF
FLAT BLACK

27
WHEEL
COVER
FUSELAGE
BOTTOM
COLOR

23
INNER
WHEEL
ALUMINUM

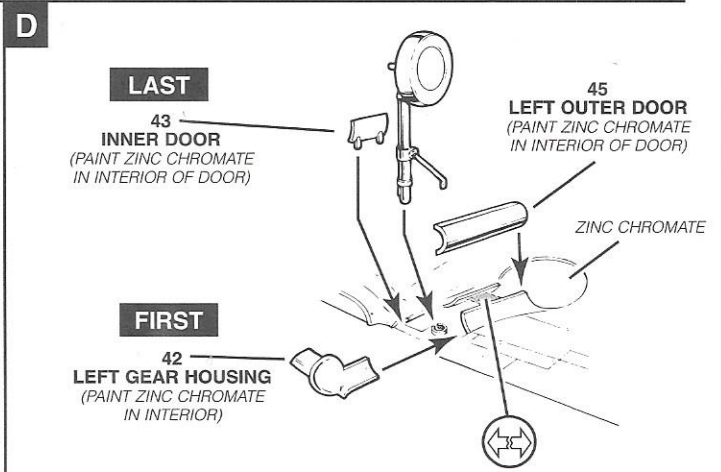

LAST

43
INNER DOOR
(PAINT ZINC CHROMATE
IN INTERIOR OF DOOR)

45
LEFT OUTER DOOR
(PAINT ZINC CHROMATE
IN INTERIOR OF DOOR)

FIRST

42
LEFT GEAR HOUSING
(PAINT ZINC CHROMATE
IN INTERIOR)

A

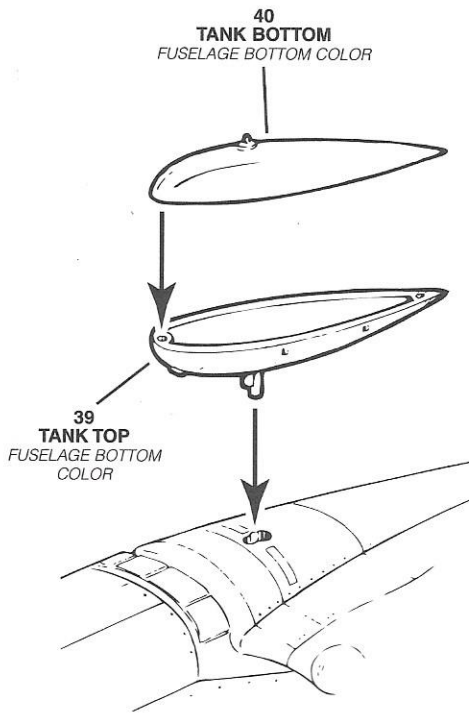

B

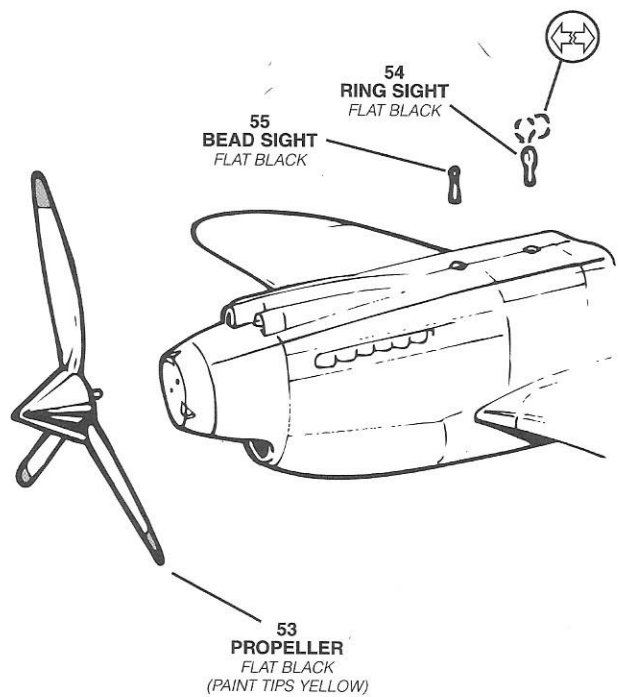

C

OPEN CANOPY

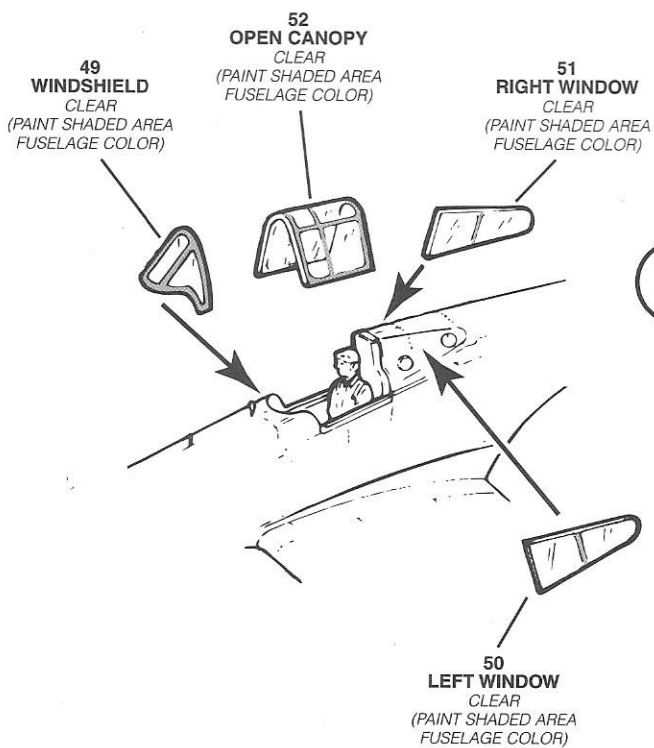

CLOSED CANOPY

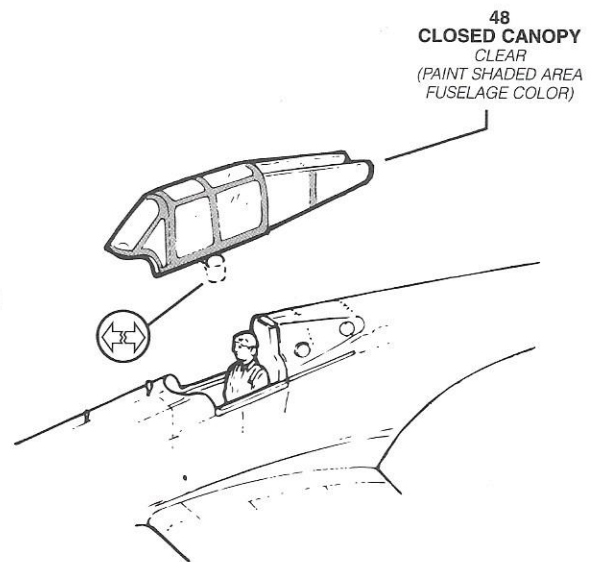

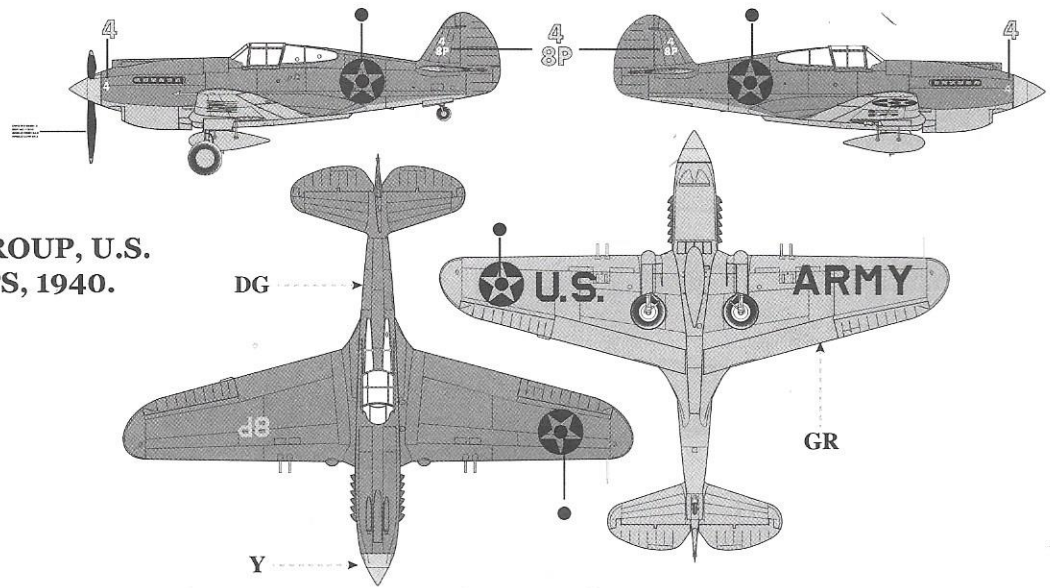

CURTISS P-40B
8TH PURSUIT GROUP, U.S.
ARMY AIR CORPS, 1940.

CURTISS
TOMAHAWK IIA
403 SQUADRON,
ROYAL CANADIAN
AIR CORPS,
BAGINTON,
ENGLAND, 1941.

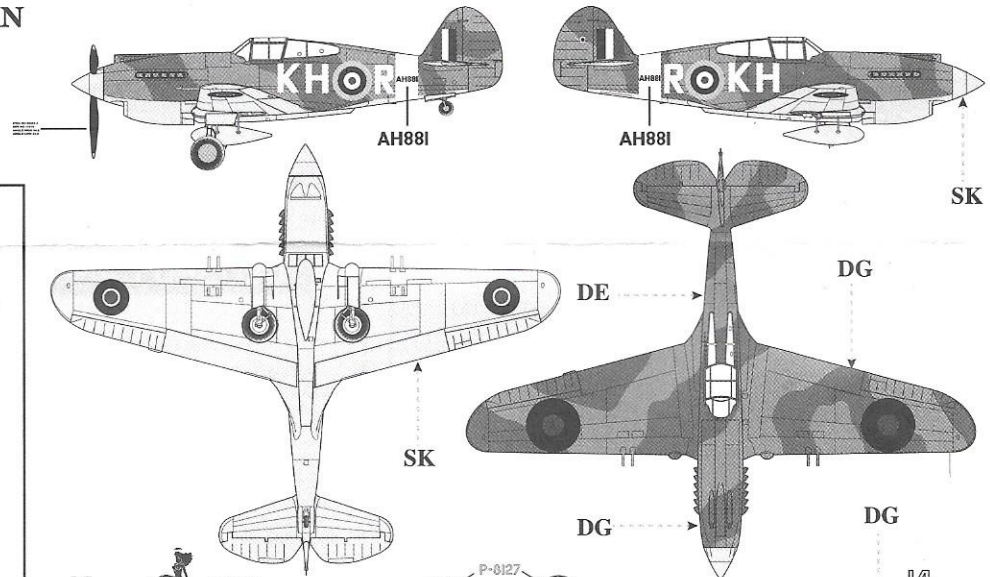

PAINT COLORS	
DE	DARK EARTH FS 30118
DG	DARK GREEN/ OLIVE DRAB FS 34079
SK	SKY FS 34504
RD	RED
GR	GRAY FS 36440
Y	YELLOW FS 13538

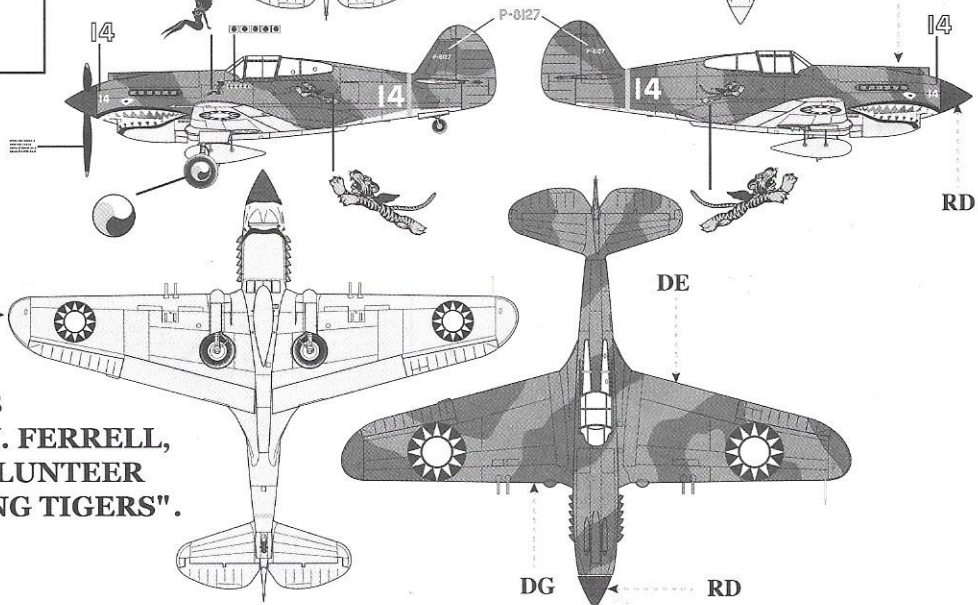

CURTISS P-40B
PILOT JOHN W. FERRELL,
AMERICAN VOLUNTEER
GROUP, "FLYING TIGERS".