

eduard

1:35



FIRST, A FEW WORDS...

...ON THE WAR:

The Second World War, from a German perspective, was not evolving favorably in 1943. Heavy losses at Stalingrad, the capitulation of German and Italian forces in North Africa in May, the defeat at the Battle of Kursk in July, and the Allied landings in Italy put increasing stresses on the German military. Furthermore, an increasingly concentrated fury from above in the form of the allied bombing campaign appeared that threatened to reduce the Reich to rubble. This campaign began to extract a heavy toll on the German ability to produce and support her weapons, including the production of tanks. On the other hand, war production in the Soviet Union and the United States steadily increased, and production figures attained were in the thousands. The German planners and designers were faced with some difficult decisions with respect on how to address the situation. One effective method was to construct a series of tank hunter/destroyers on the chassis of existing tanks, resulting in vehicles such as the Sturmgeschütz, for use in infantry support. One huge advantage of such vehicles was their relative simplicity when compared to the classic tank. There was no turret, and the complexities associated with the manufacture and installation of the turret were eliminated. The vehicles would be armed with Pak 39 anti tank guns of 75mm caliber, and were called Jagdpanzer (Fighter Tank - Tank Destroyer). Progressively, this concept was applied to other tank chassis as well.

...ON PRODUCTION:

In December, 1943, the factory of BMM, in Prague, was tasked with the production of such a vehicle, based on the proven Pz.38(t) chassis. At the time, there was in production an earlier generation of antitank vehicle in the form of the Sd.Kfz. 138 Marder III. This had an antitank gun mounted in an open fighting compartment. The new vehicle, designated Jagdpanzer 38 Hetzer (Sd.Kfz. 138/2) varied considerably from its forerunner. The running gear was extended, onto which a compact structure composed of welded steel plating of 60mm frontal, 20mm rear, 10mm top and 8mm bottom thickness, was placed. The Pak 39 L48 gun was mounted offset to the right. The base of the gun was covered by a cast metal curtain of the Saukopfblende type. The top of the vehicle was equipped with an MG34 machine gun, operated by the loader and could be rearmed from inside the vehicle. Development of this vehicle progressed quickly, and April, 1944, saw the road trials begin on the first three prototypes. Assembly of the first twenty pieces was also initiated, and on the 20th of April, 1944, the vehicle was demonstrated for Hitler on the occasion of his birthday. Fifty vehicles were produced in May, and these were split between test and training units. In June, the entire program was given absolute priority. June production saw the new vehicles sent to the depot at Breslau (today Wroclaw), and then on to combat units. June also saw the initiation of production of this vehicle at Skoda in Pilsen. Both facilities produced these vehicles until the spring of 1945, and were only ended by USAAF bombings. First, BMM was bombed on March 25th, 1945, and then Skoda exactly one month later. With that, the production of the Hetzer for the German war effort was terminated.

...ON THE WAR, AGAIN:

The first Hetzers produced made their way to training units. Subsequent production was intended for service with individual units of the Wehrmacht and the Waffen SS. The first service unit to employ the Hetzer was actually Panzerjäger Abteilung 731, which saw action at the beginning of August at Warsaw. The fall of 1944 saw both production and training of crews achieve a good pace, peaking in January of 1945 when 468 vehicles were delivered. To the end of 1944, a total of 1507 Hetzer vehicles were produced, along with 101 Bergehetzer recovery vehicles. February, 1945, saw the beginnings of a slow but steady decline in production. Despite this, another 1246 vehicles came off the production lines until May, and the Hetzer thus became one of the most significant fighting vehicles of the last year of the war fielded by the Wehrmacht and the Waffen SS. Their combat use was intense and included use on all fronts that Germany was engaged. They saw action against the western Allies at Arnhem, and they also took part in the



The original Pz.38(t) light tank
foto V.Francev via MBI



Marder IIIIM, the first generation
of the German tank destroyers
foto V.Francev via MBI

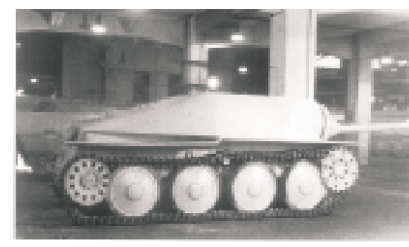

The mock-up in January 1944
foto V.Francev via MBI

last German offensive of the war in the Ardennes. They saw combat service in Budapest and on the Oder, and through on to the defense against advancing Soviet troops on Berlin. In the last days of the war, they were used in Germany's final counterattacks at Bautzen. They saw action in the defense of Moravia, confronting elements of the 1st Czechoslovak Tank Brigade in the fighting for Ostrava. In the land of its origin, remaining Hetzers ended the war trying to cross demarcation lines at Prague to surrender to American forces. In Prague, where there was an anti-German uprising on the 5th of May, 1945, several tens of Hetzers saw action on both sides. Obviously, the German side had them at their disposal, and the insurgents obtained their examples from the factory depot, but these were mainly equipped only with machine guns. Significant fighting that had direct bearing on the Prague fighting, was carried out by the First

Division ROA, led by General Bunacenko. This unit, composed of former Soviet POWs fighting on the German side, fought here on the side of the insurgents and effectively held back German progress over a span of two days. They had, among their strength, 10 Hetzers. The end of the war did not mean the end of the Hetzer. After the fall of the Reich, they were placed back into production, and entered service with the armed forces of Czechoslovakia and Switzerland. In Czechoslovakia, they served well into the fifties, and the seventies with the Swiss. Designated ST-1, Czechoslovak Hetzers found their way to scrap heaps, and the Swiss Pzj.G-13 found their way into museums and private collections, and so today represents some of the best and most numerous examples of German World War Two armor in existence today.

...ON THE MODEL:

Through its nine month wartime production history, the Hetzer went through intensive development. Some machines underwent upgrades, such as a redesign of the cast cover which was smaller and reshaped along the lines of the articulated cover known as the Saukopfblende. As well as being redesigned, it was made lighter and more elegant. The roadwheels also saw a change that made them lighter, and their assembly was made with the use of rivets as apposed to nuts and bolts. The driver's visor went from a heavy cast cover, it received a cut sheet metal piece. Substantial changes were made to the exhaust. The relatively complicated perforated muffler cover was replaced by a diagonal metal tube. This led to some changes in the engine covers as well. Changes didn't escape the drive sprockets, nor the idler wheels, of which there are seven known types. Your model represents an initial version, before many of these changes were instigated. In this guise, Hetzers left the factory between April, 1944 to sometime during the summer of the same year. Your kit also includes both known versions of the cannon that were mounted into this incarnation of the vehicle. We hope that you will find hours of pleasure during the construction of your Hetzer.

Jagdpanzer 38 Hetzer (Sd.Kfz.138/2) Specifications

Hull length: 4766mm
 Length with cannon: 6270mm
 Width: 2526mm
 Height: 2100mm
 Combat Weight: 16t
 Maximum Road Speed: 40km/h

Maximum Offroad Speed: 25km/h
 Engine: Praga AE
 Displacement: 7.8L
 Power Rating: 160k/118kW
 Armament: 1 x 7.5cm Pak 39/L48 with 41 rounds of ammunition
 1 x 7.92mm MG34 with 600 rounds of ammunition
 Armor Plating Thickness:
 Frontal: 60mm, Side: 20mm,
 Bottom: 10mm, Roof: 8mm



Hetzers received an application of European Yellow (RAL 7028) at the factory, and in some cases also received a second application of irregular fields of olive green. This machine was supplied to a training unit, probably to Panzer Jäger Schule in Milau in eastern Prussia.



The first prototype at April 1st, 1944
 foto V.Francev via MBI



The production sample of the early version.
 foto V.Francev via MBI



The final version of the Jagdpanzer 38.
 foto V.Francev via MBI



Swiss Pzj.G-13 in post-war service.
 foto V.Francev via MBI

ATTENTION



UPOZORNĚNÍ



ACHTUNG



ATTENTION



Carefully read instruction sheet before assembling. When you use glue or paint, do not use near open flame and use in well ventilated room. Keep out of reach of small children. Children must not be allowed to suck any part, or pull vinyl bag over the head.



Před započítím stavby si pečlivě prostudujte stavební návod. Při používání barev a lepidel pracujte v dobře větrané místnosti. Lepidla ani barvy nepoužívejte v blízkosti otevřeného ohně. Model není určen malým dětem, mohlo by dojít k požití drobných dílů.



lire soigneusement la fiche d'instructions avant d'assembler. Ne pas utiliser de colle ou de peinture à proximité d'une flamme nue, et aérer la pièce de temps en temps. Garder hors de portée des enfants en bas âge. Ne pas laisser les enfants mettre en bouche ou sucer les pièces, ou passer un sachet vinyl sur la tête.



Von dem Zusammensetzen die Bauanleitung gut durchlesen. Kleber und Farbe nicht nahe von offenem Feuer verwenden und das Fenster von Zeit zu Zeit Belüftung öffnen. Bausatz von kleinen Kindern fernhalten. Verhüten Sie, daß Kinder irgendwelche Bauteile in den Mund nehmen oder Plastiktüten über den Kopf ziehen.

INSTRUKTION SIGNS * INSTR. SYMBOLY * INSTRUKTION SINNBILDEN * SYMBOLES



OPTIONAL
VOLBA
FACULTATIF
NACH BELIEBEN



BEND
OHNOUT
PLIER SIL VOUS PLAÎT
BITTE BIEGEN



OPEN HOLE
VYVRÁT OTVOR
FAIRE UN TROU
OFFNEN



SYMMETRICAL ASSEMBLY
SYMETRICKÁ MONTÁŽ
MONTAGE SYMÉTRIQUE
SYMMETRISCHE AUFBAU



NOTCH
ZÁŘEZ
L'INCISION
DER EINSCHNITT



REMOVE
ODRÍZNOUT
RETIRER
ENTFERNEN



APPLY EXPRESS MASK
POUŽIT EXPRESS MASK
NABARVIT PŘED SLEPENÍM
AND PAINT BEFORE
GLUING

PARTS



DÍLY



TEILE



PIÈCES

PLASTIC PARTS

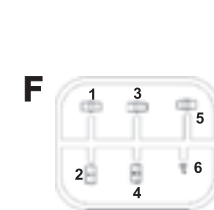
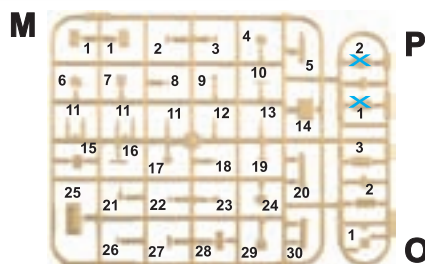
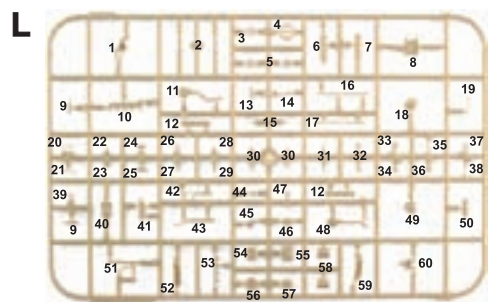
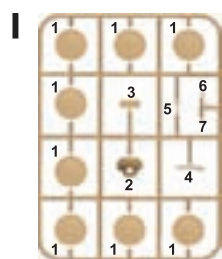
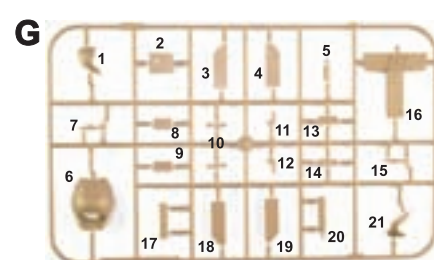
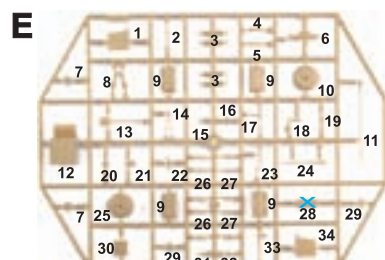
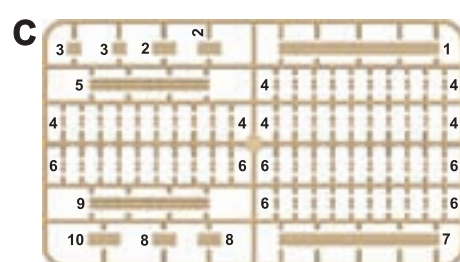
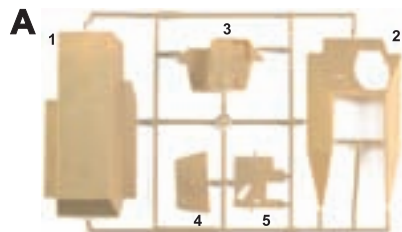

S - STRING



PRINT

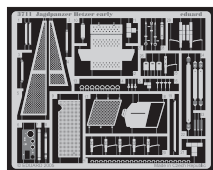
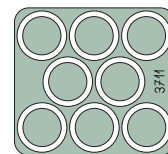

-Parts not for use, -Teile werden nicht verwendet, -Pièces a ne pas utiliser, -Tyto díly nepoužívejte při stavbě, -使わない部品

PE - PHOTO ETCHED
DETAIL PARTSeduard
MASK

2 pcs.

COLOURS



BARVY



FARBEN



PEINTURE

GSI Creos (GUNZE)		
AQUEOUS	Mr.COLOR	
[H 3]	[3]	RED
[H 12]	[33]	FLAT BLACK
[H 18]	[28]	STEEL
[H 32]	[]	FIELD GRAY
[H 37]	[43]	WOOD BROWN

AQUEOUS	Mr.COLOR	
[H 47]	[41]	RED BROWN
[H 70]	[60]	GRAY
[H 76]	[61]	BURNT IRON
[H 77]	[33]	TIRE BLACK
[H 78]	[12]	OLIVE DRAB

AQUEOUS	Mr.COLOR	
[H 79]	[39]	DARK YELLOW
[H 302]	[302]	GREEN
[H 344]	[]	RUST
[H 316]	[316]	WHITE
[]	[159]	SUPER SILVER

Mr.METAL COLOR	
[MC212]	IRON
[MC214]	DARK IRON
[MC219]	BRASS

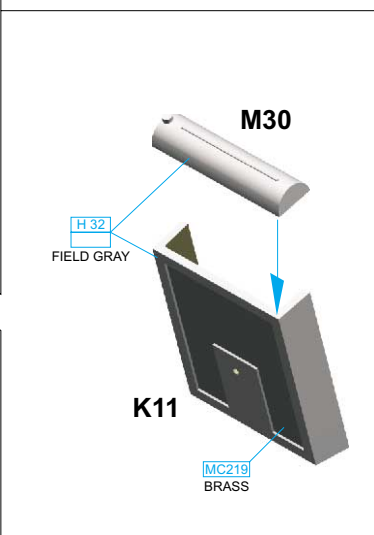
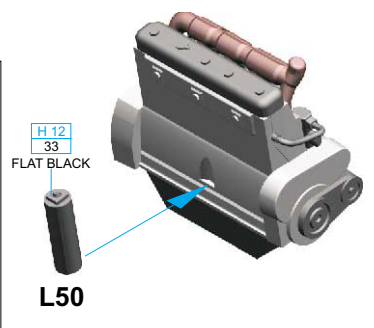
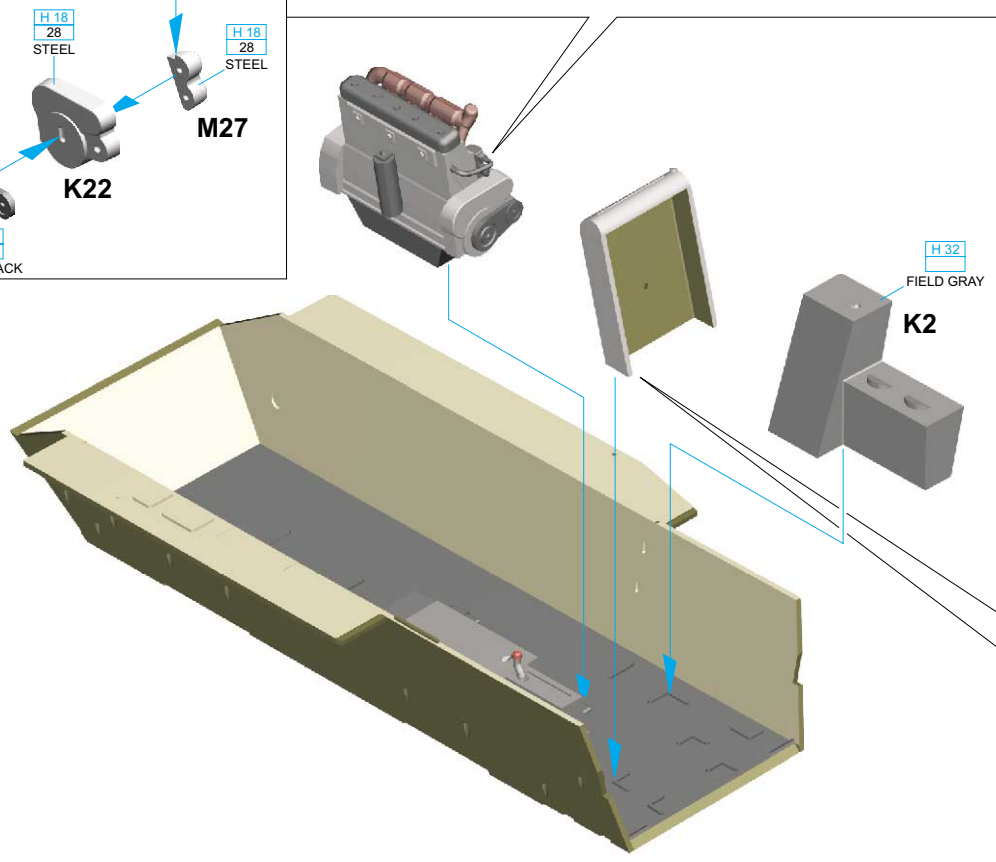
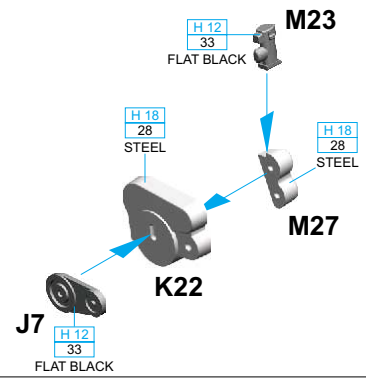
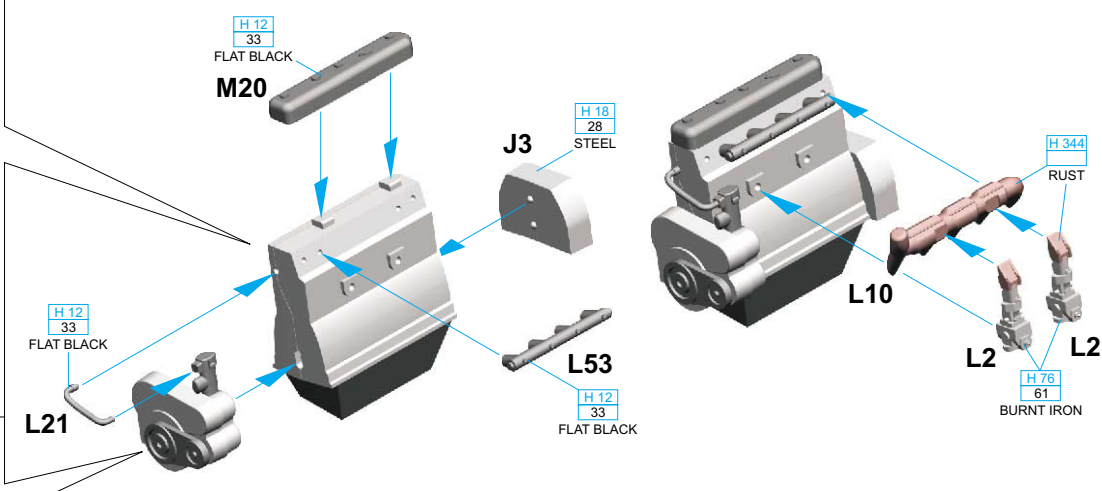
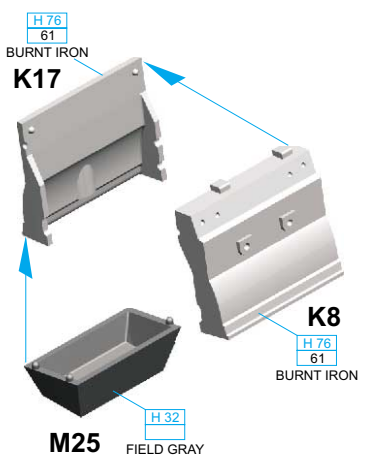
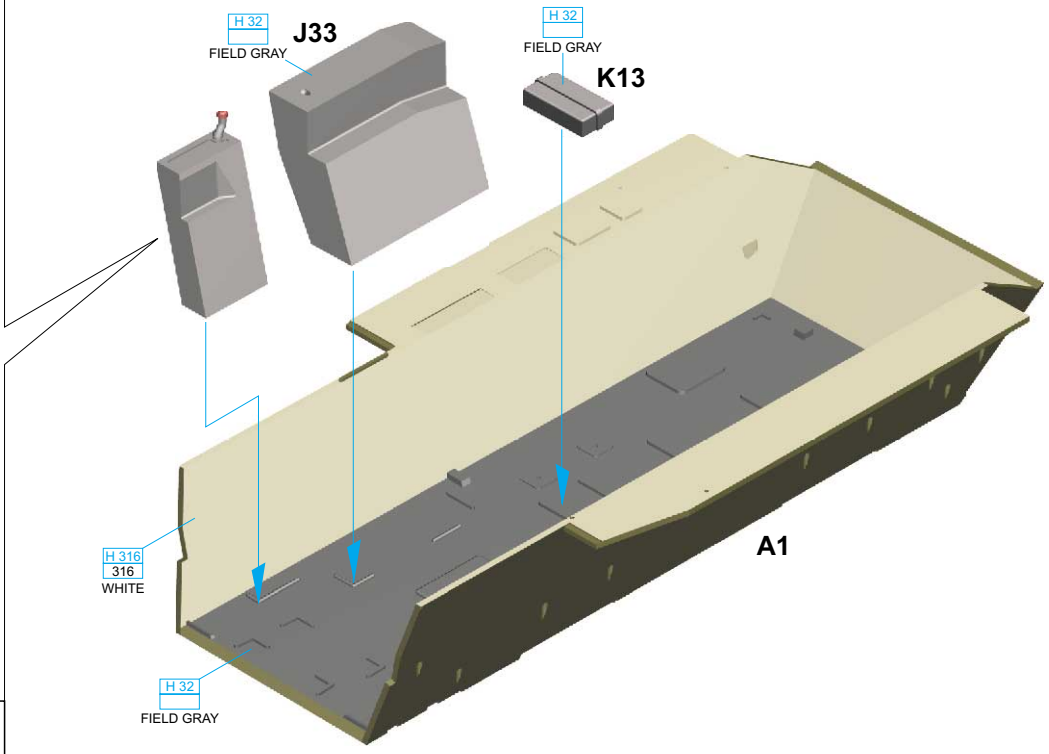
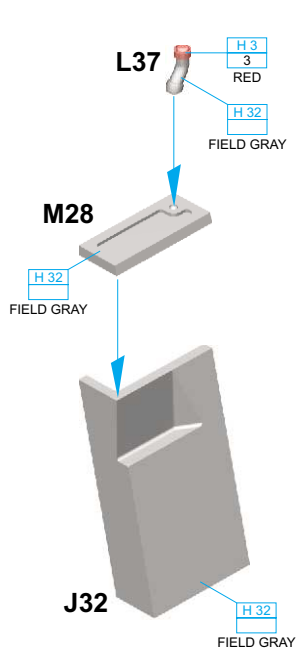

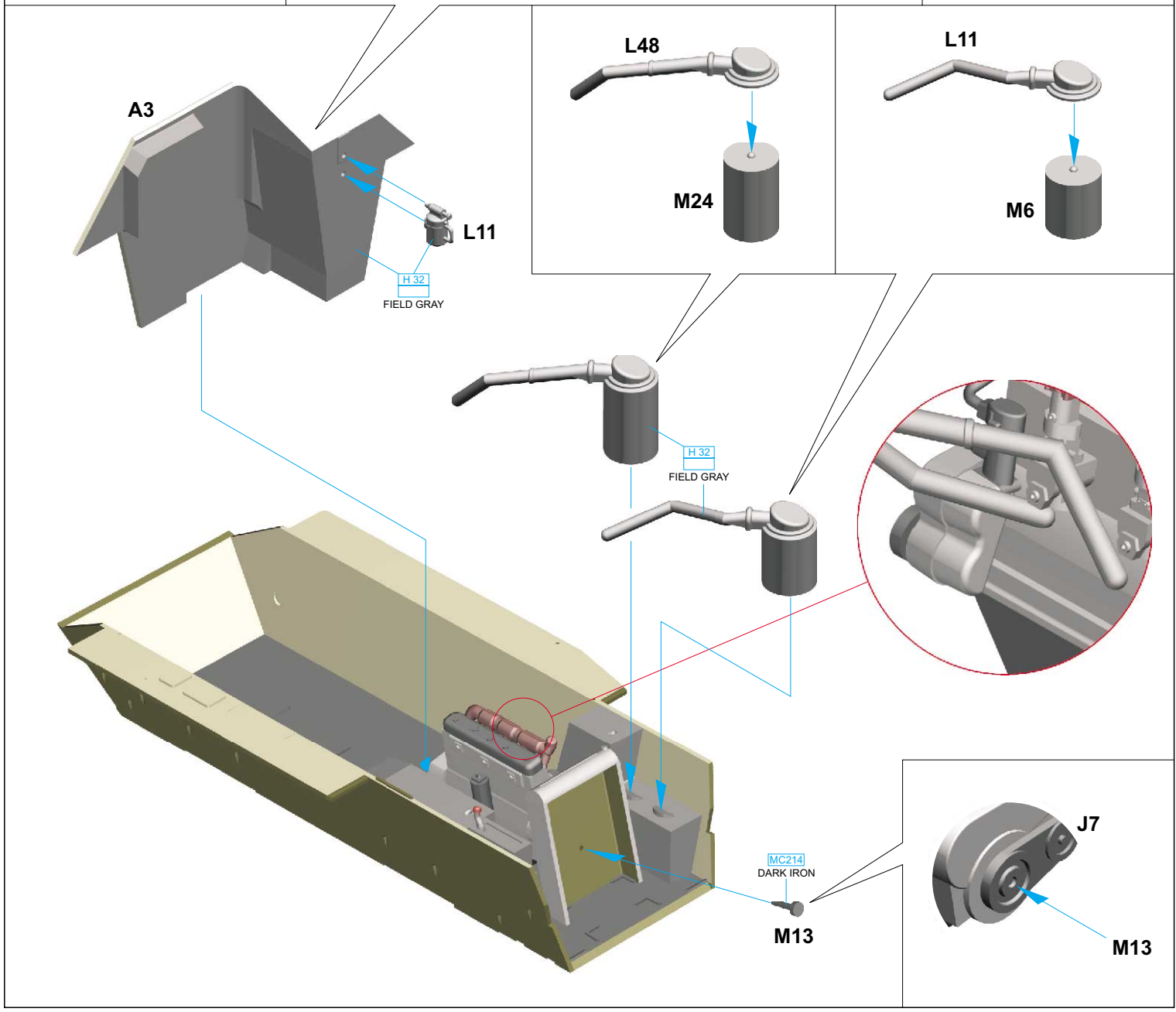
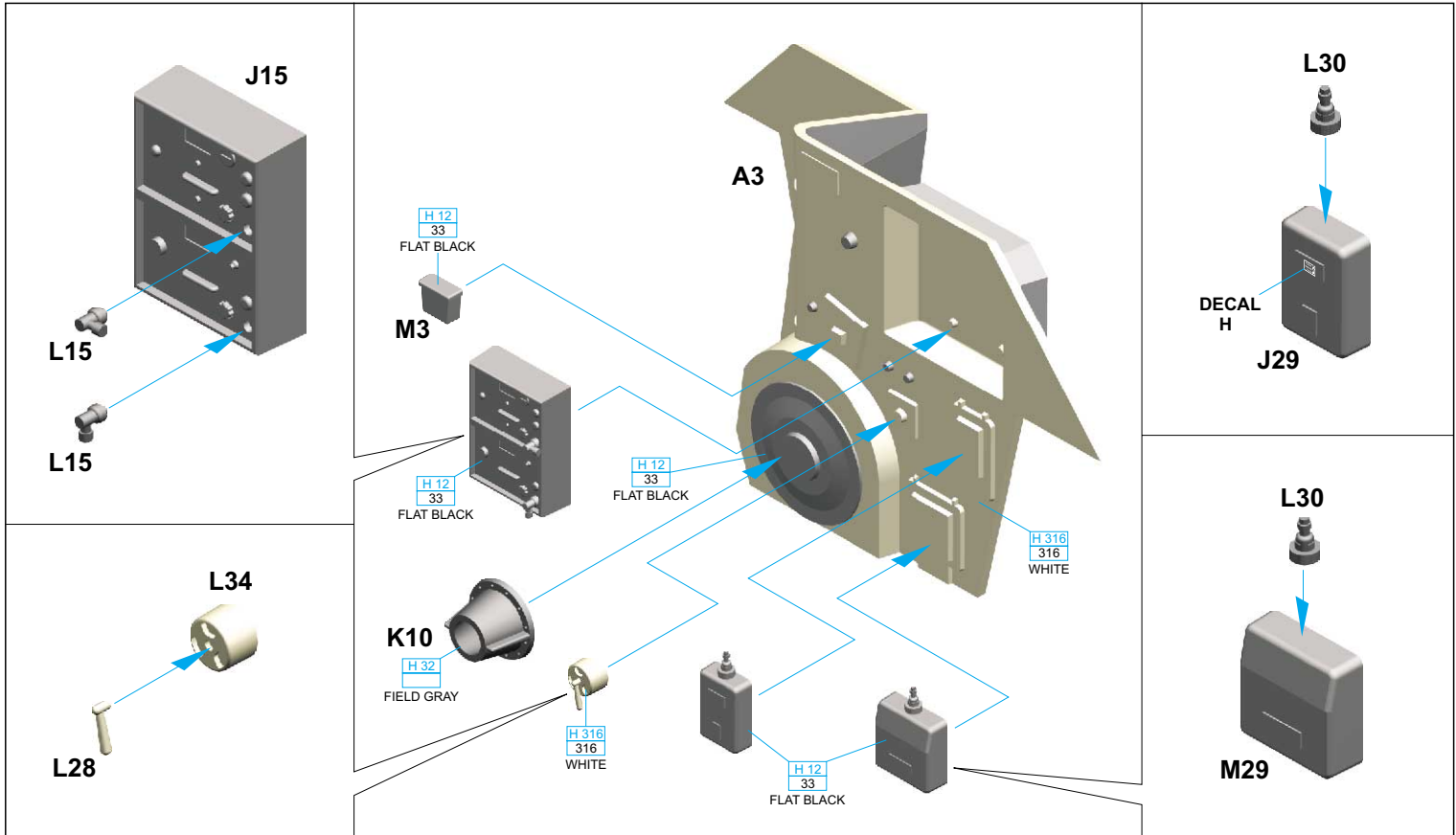

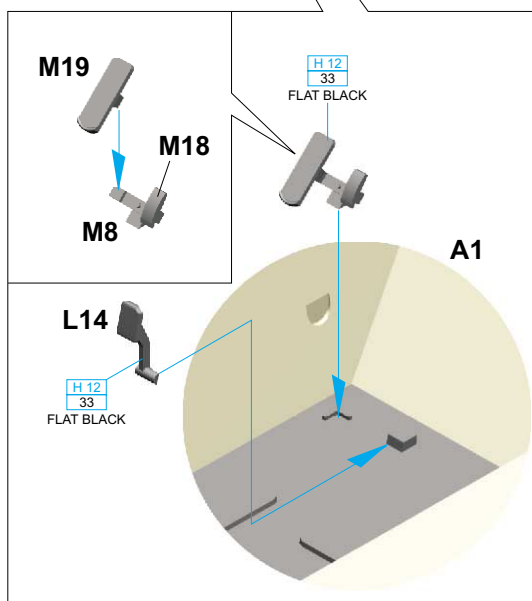
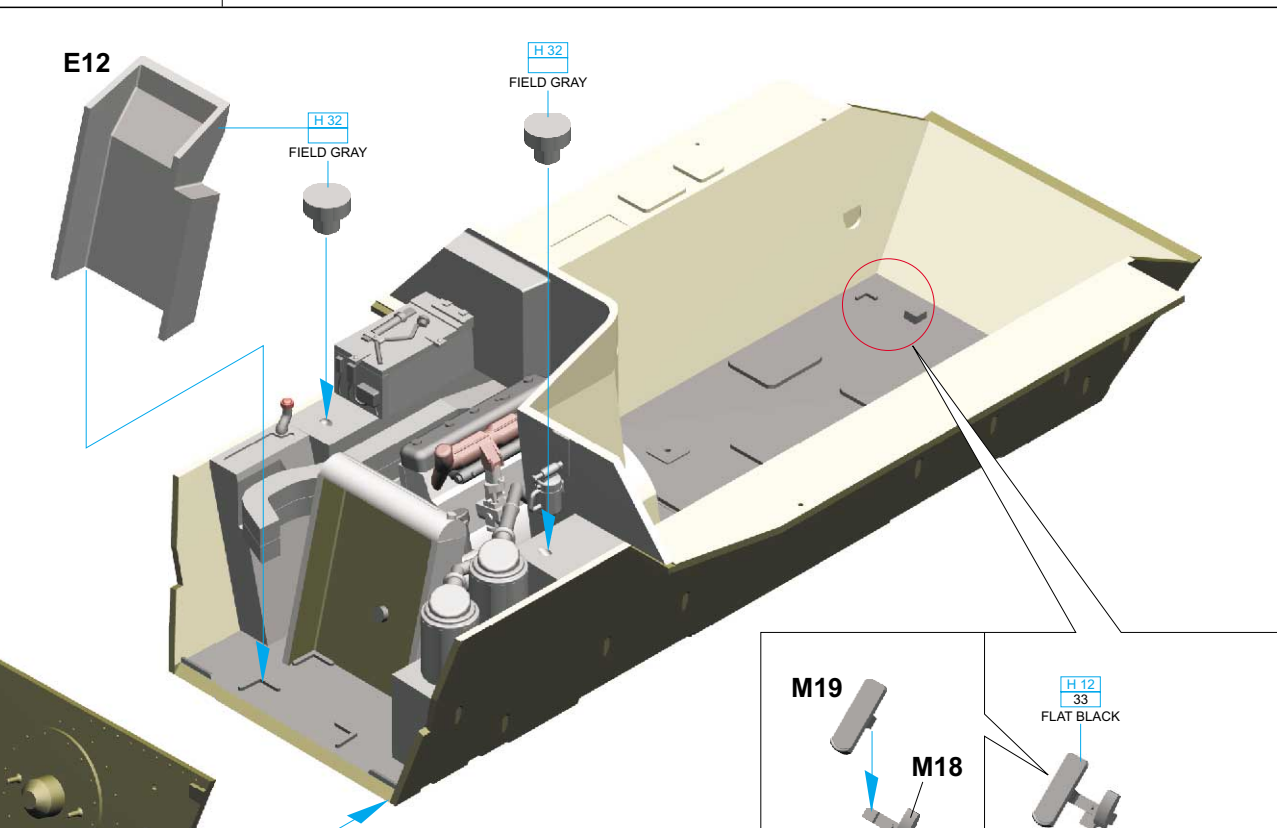
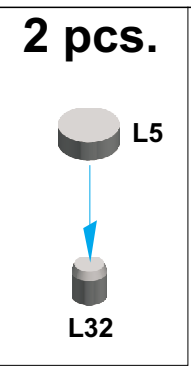
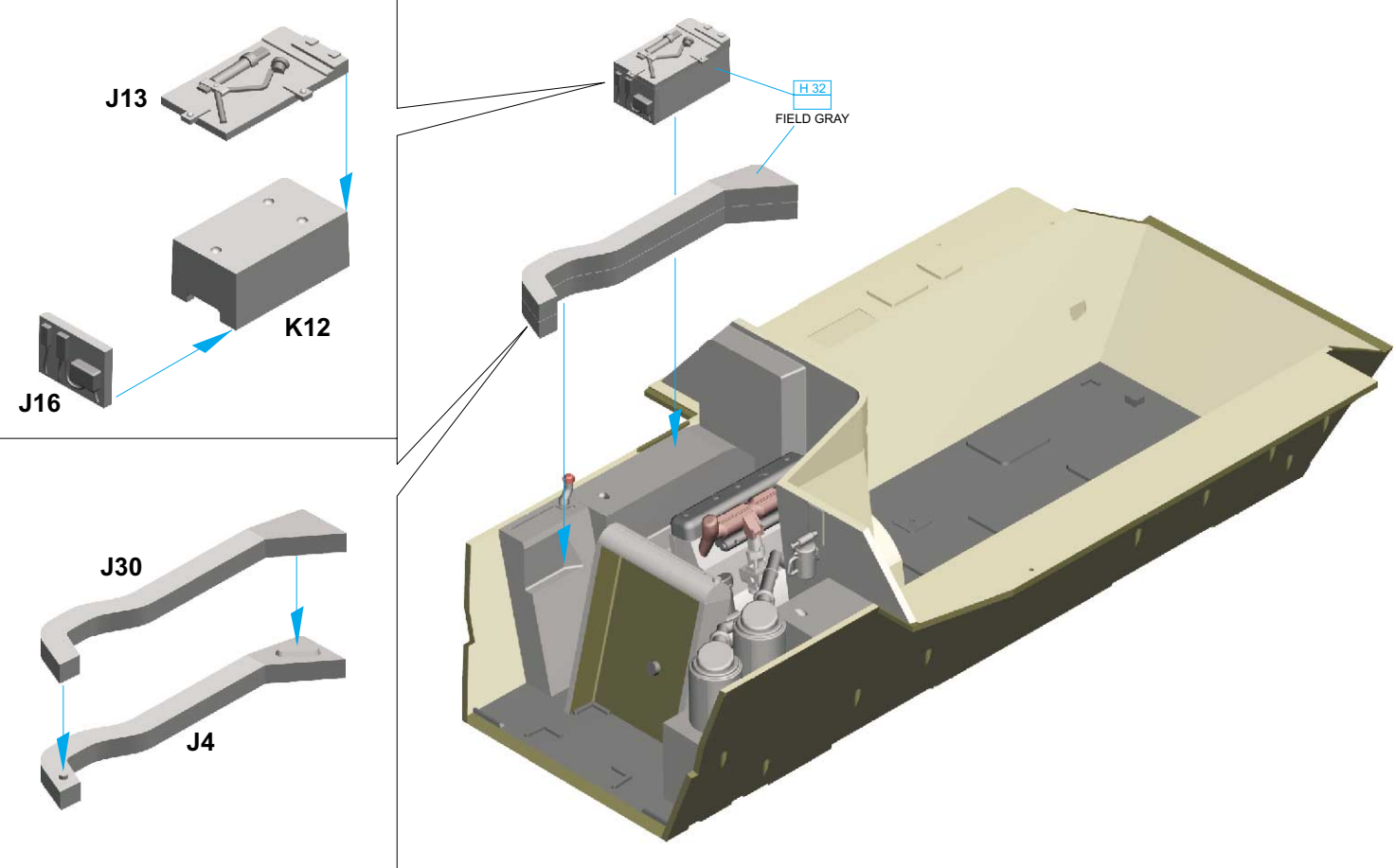

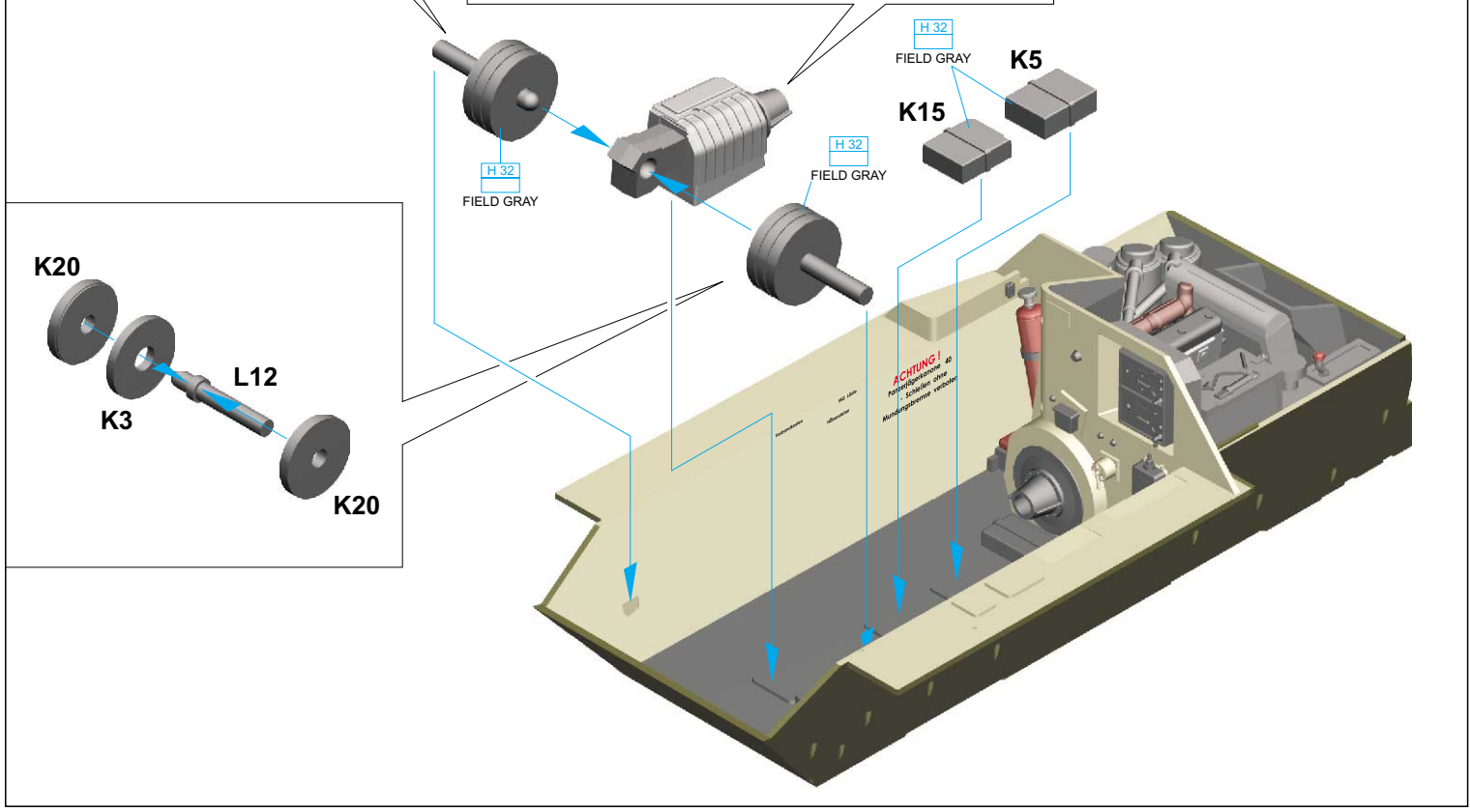
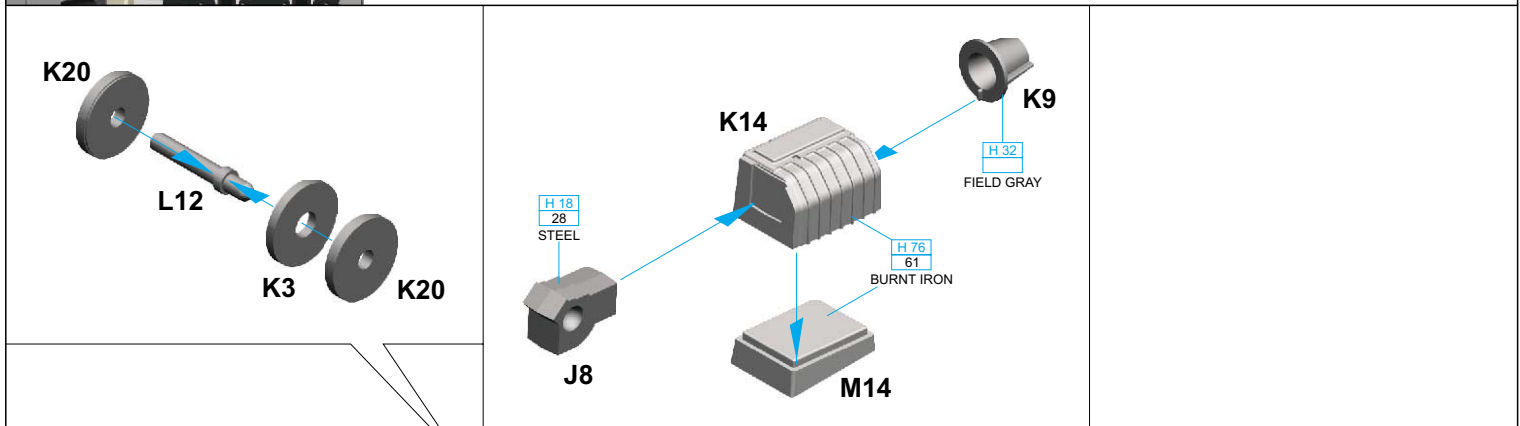
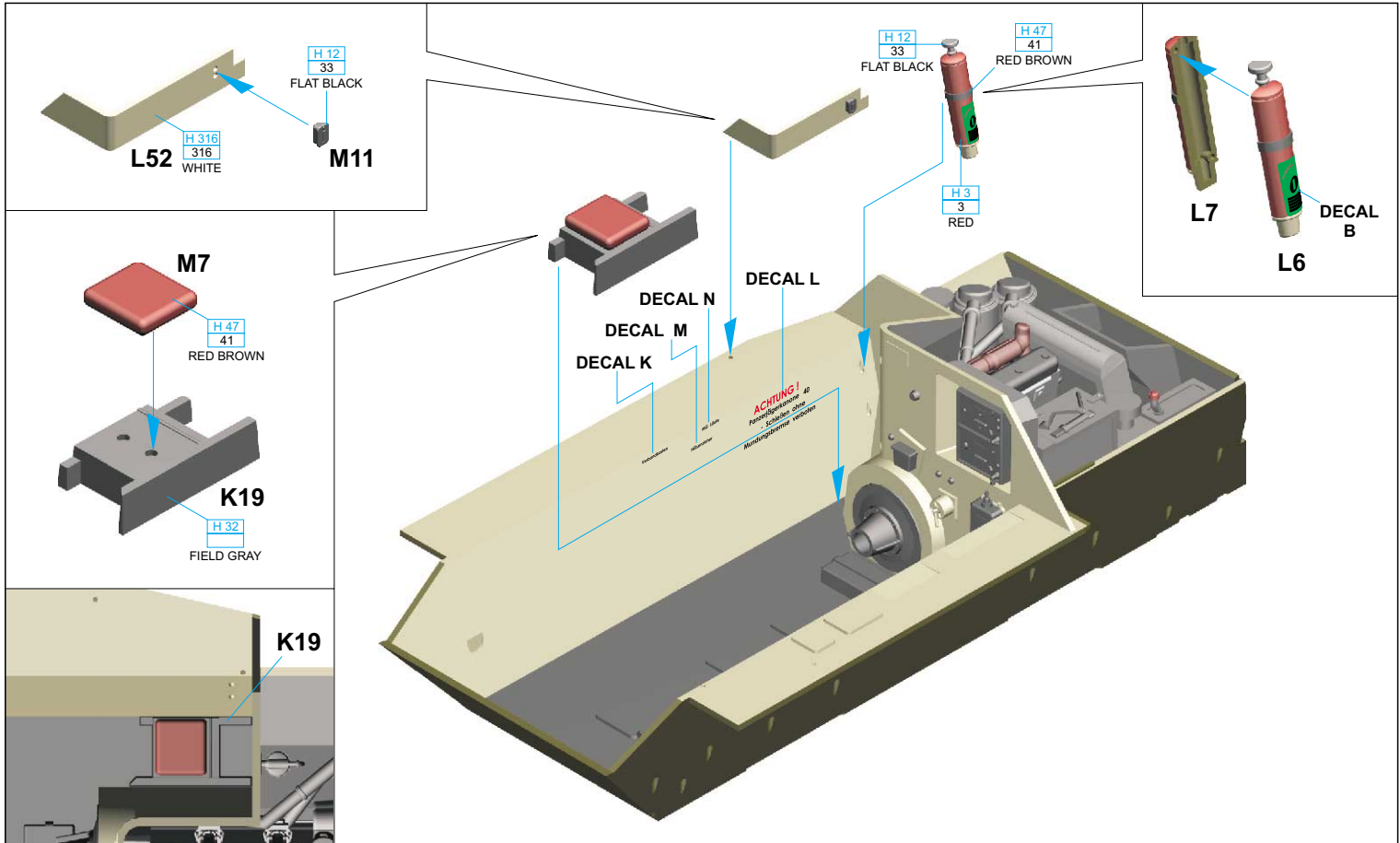

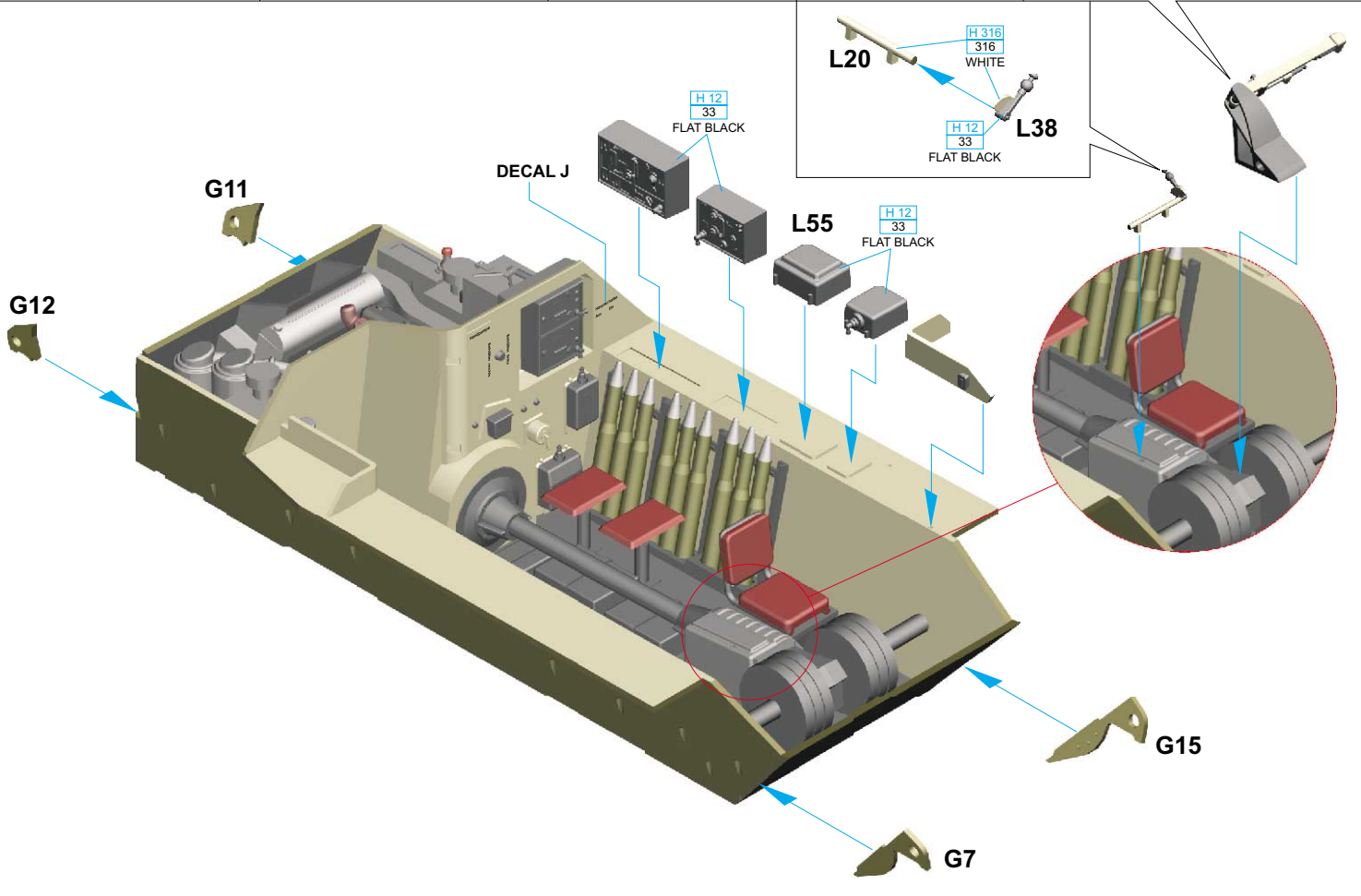
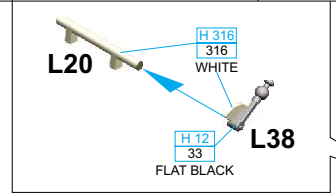
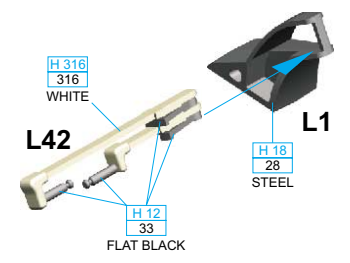
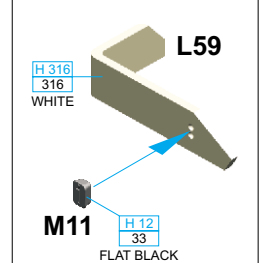
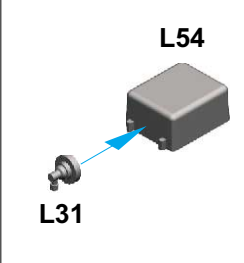
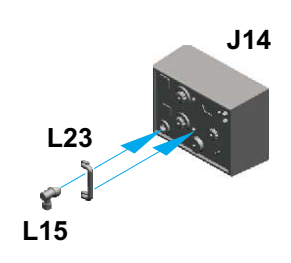
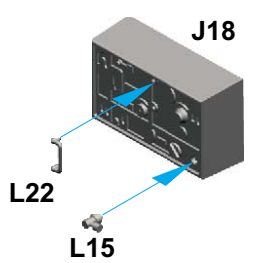
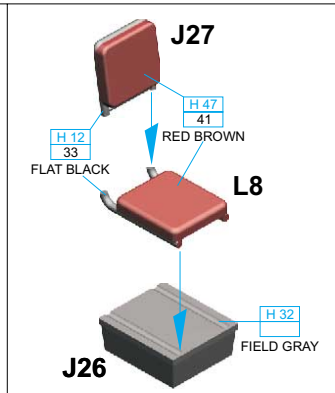
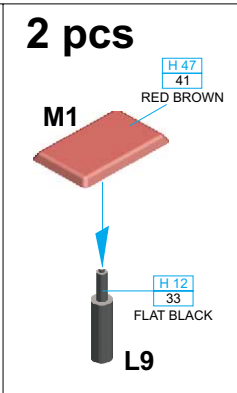
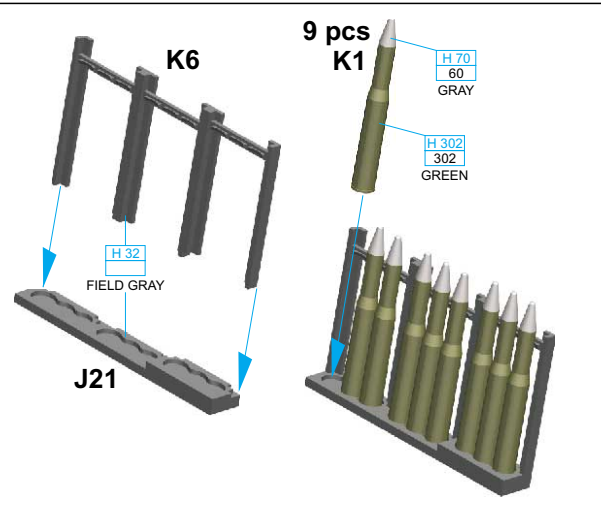
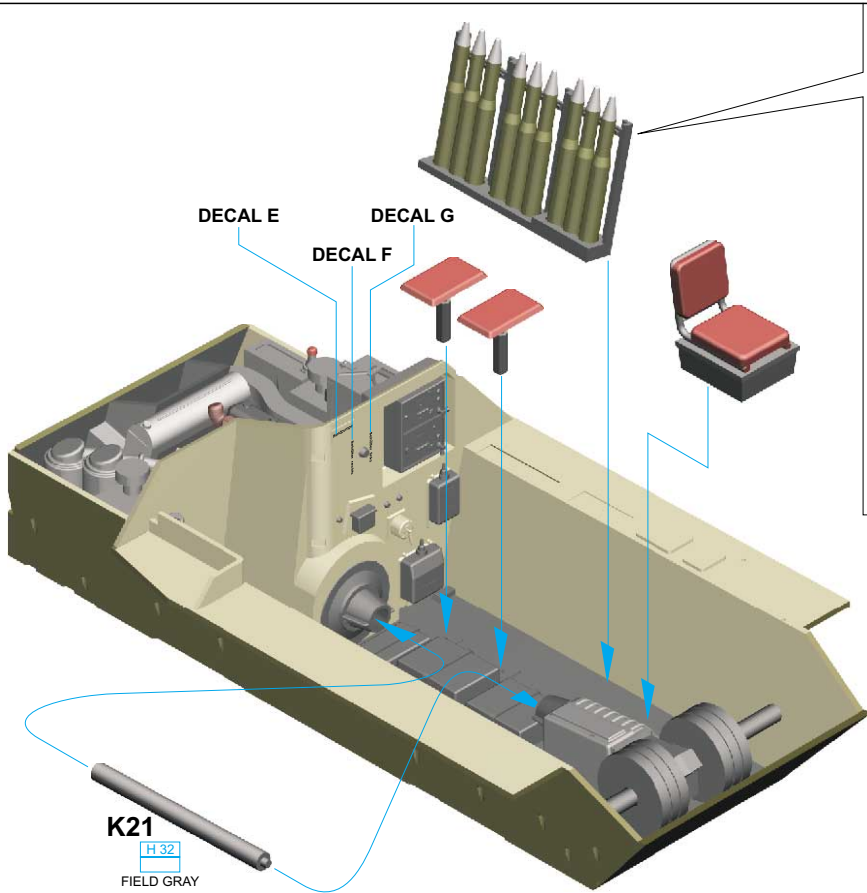

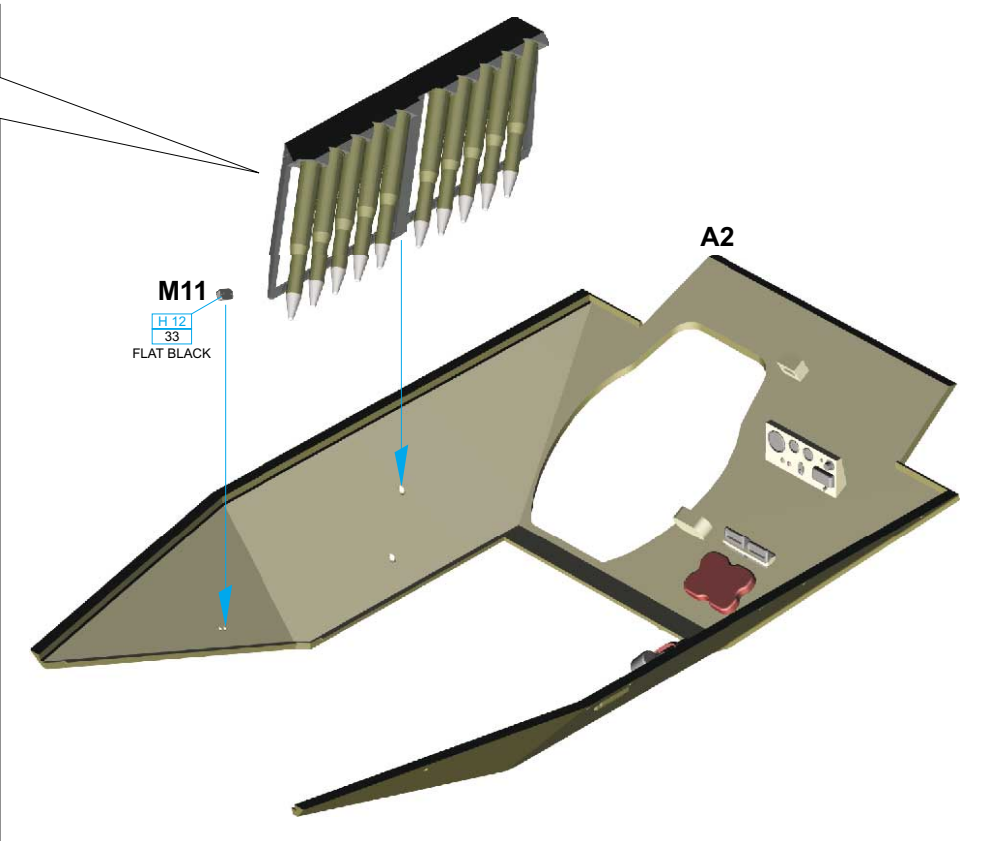
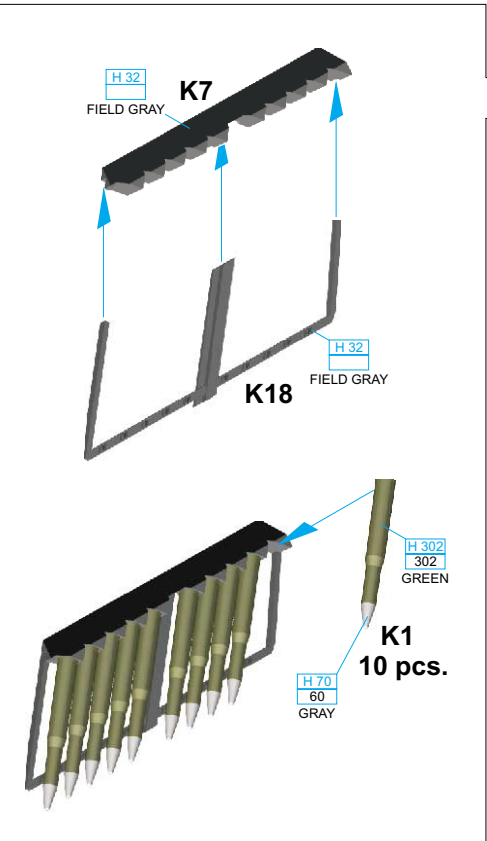
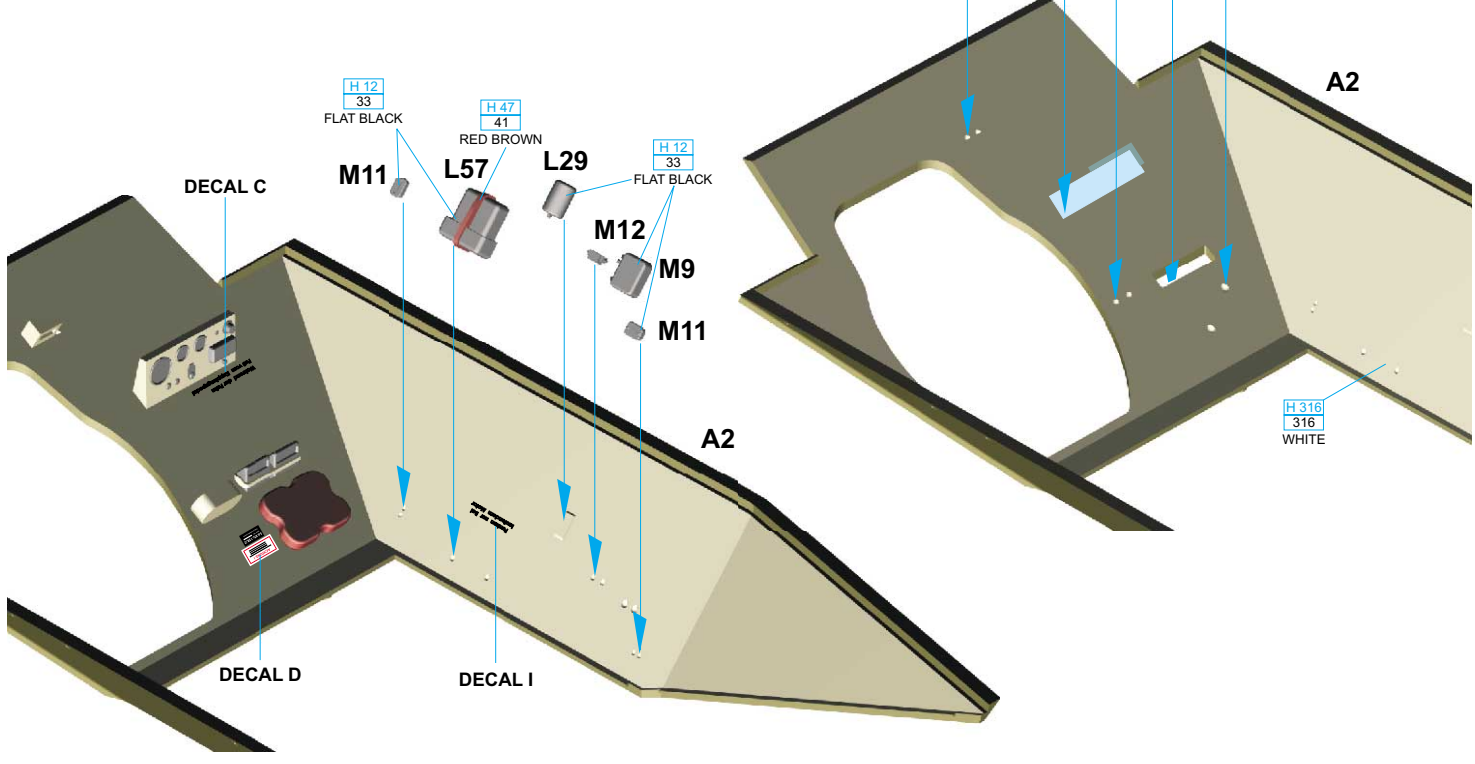
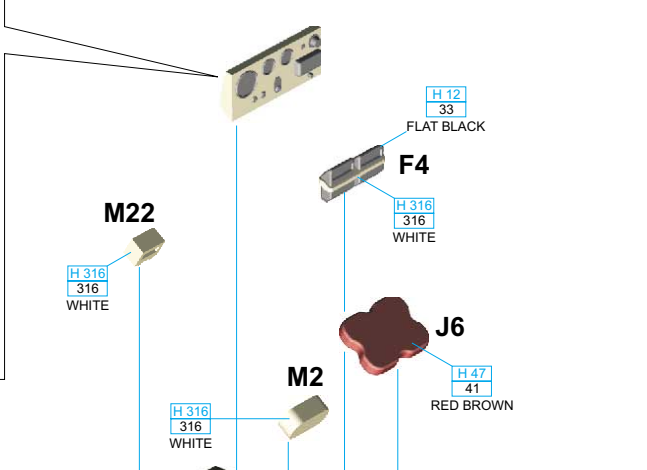
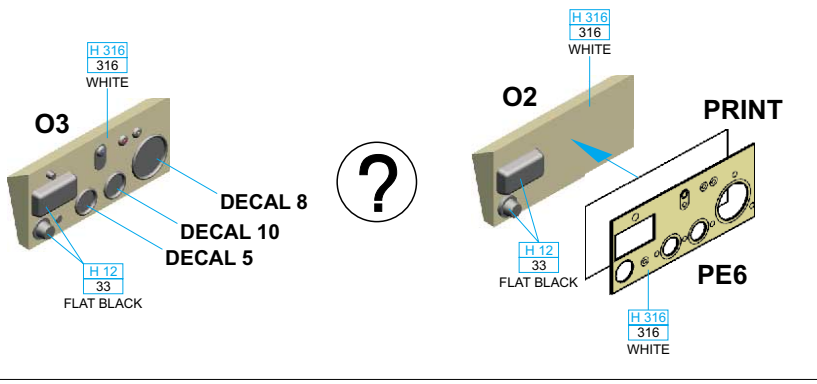

VERSION A

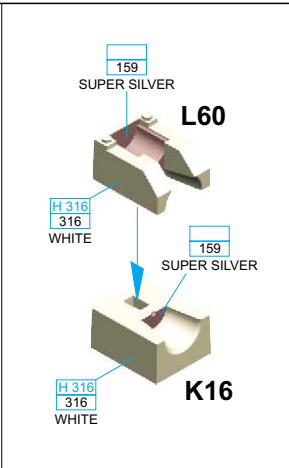
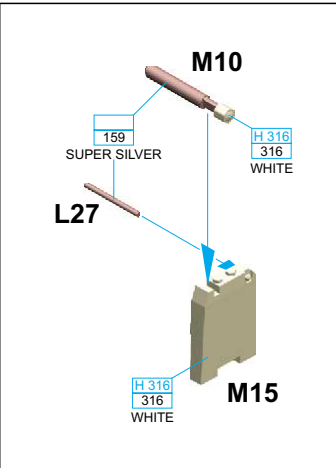
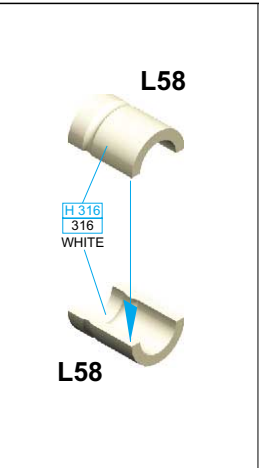
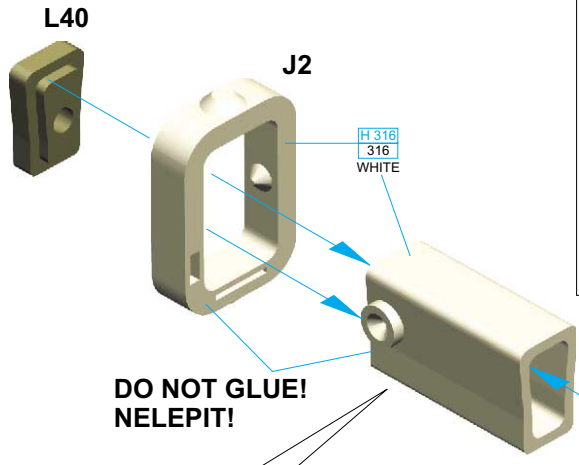

DO NOT GLUE!
NELEPIT!

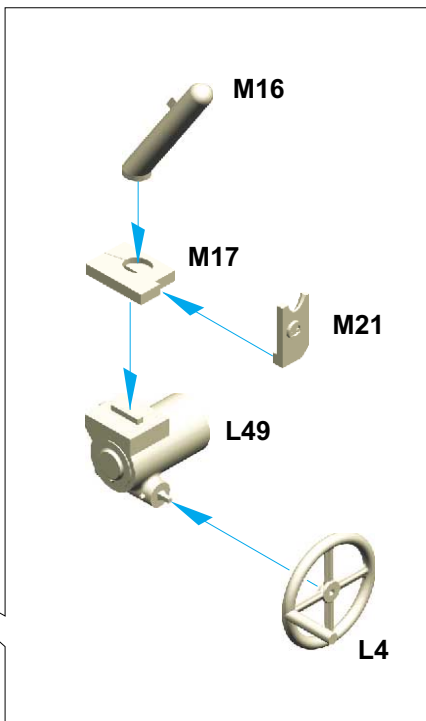
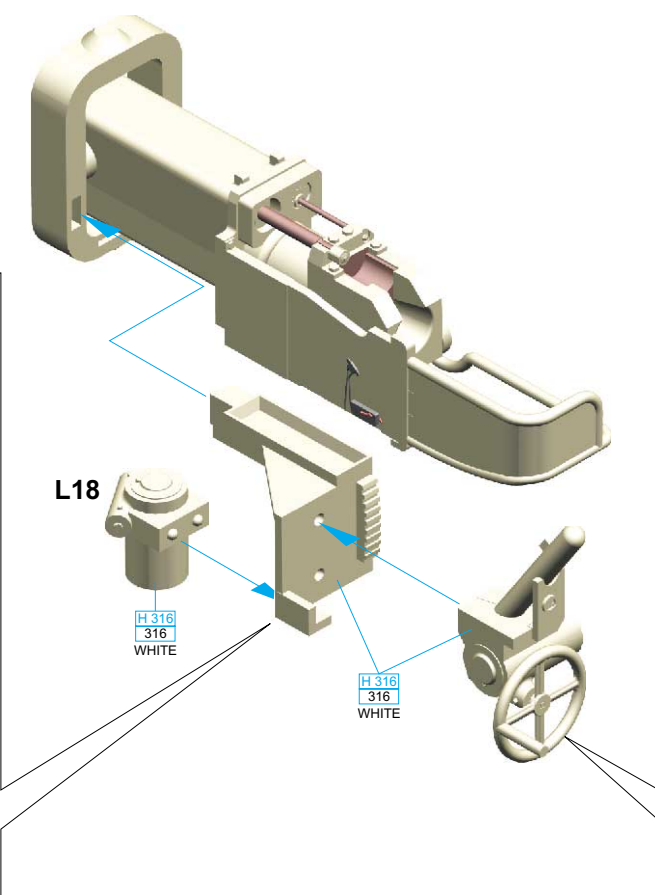
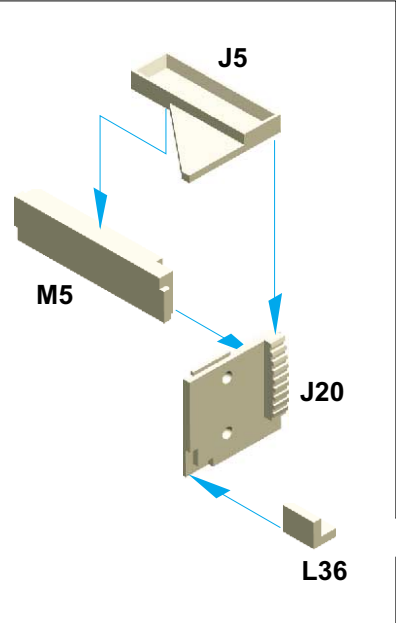
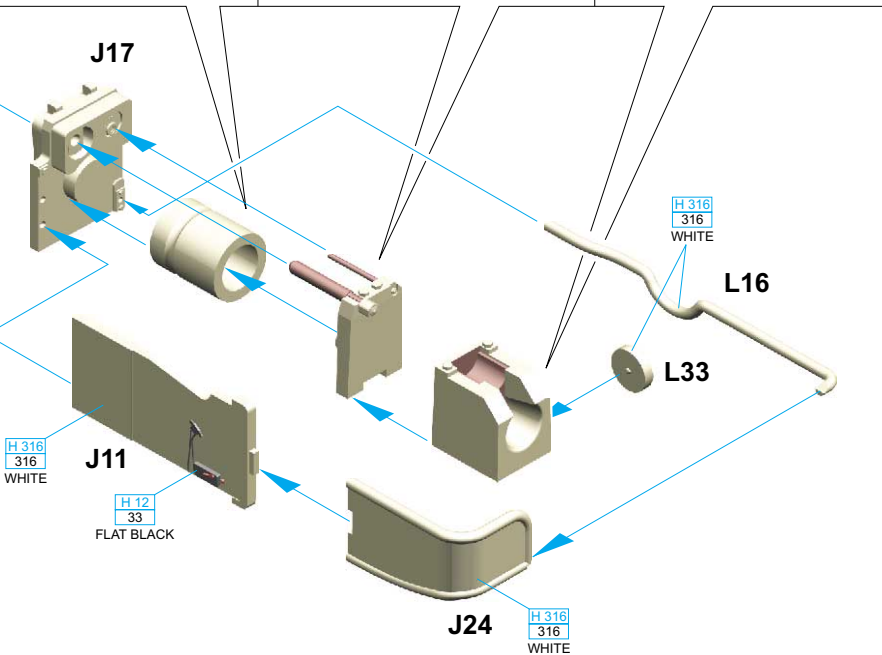
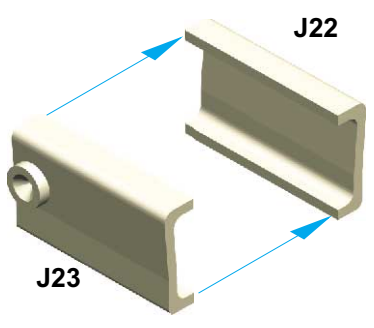

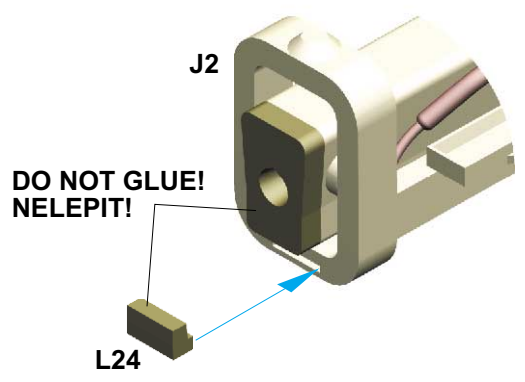
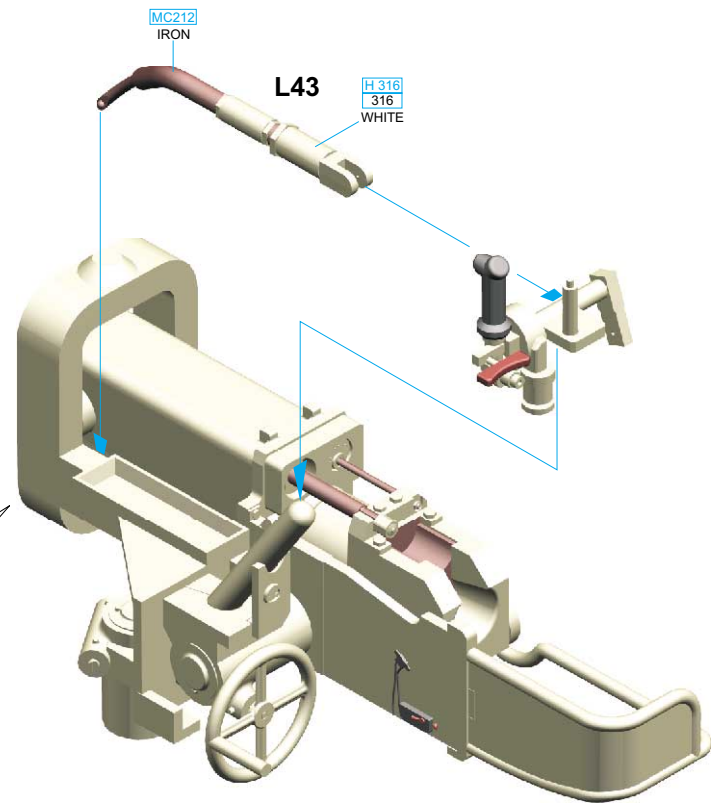
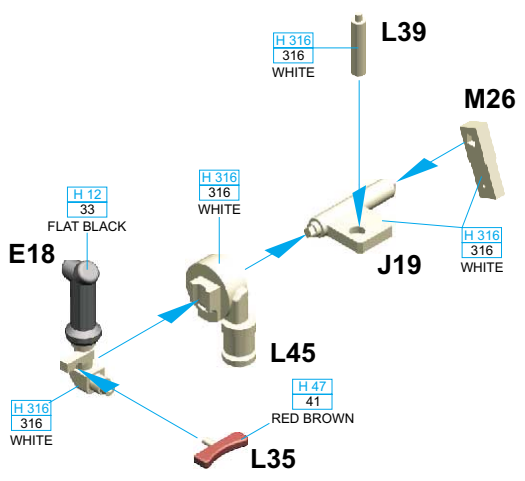

VERSION B

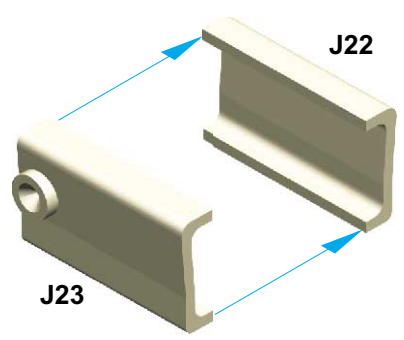
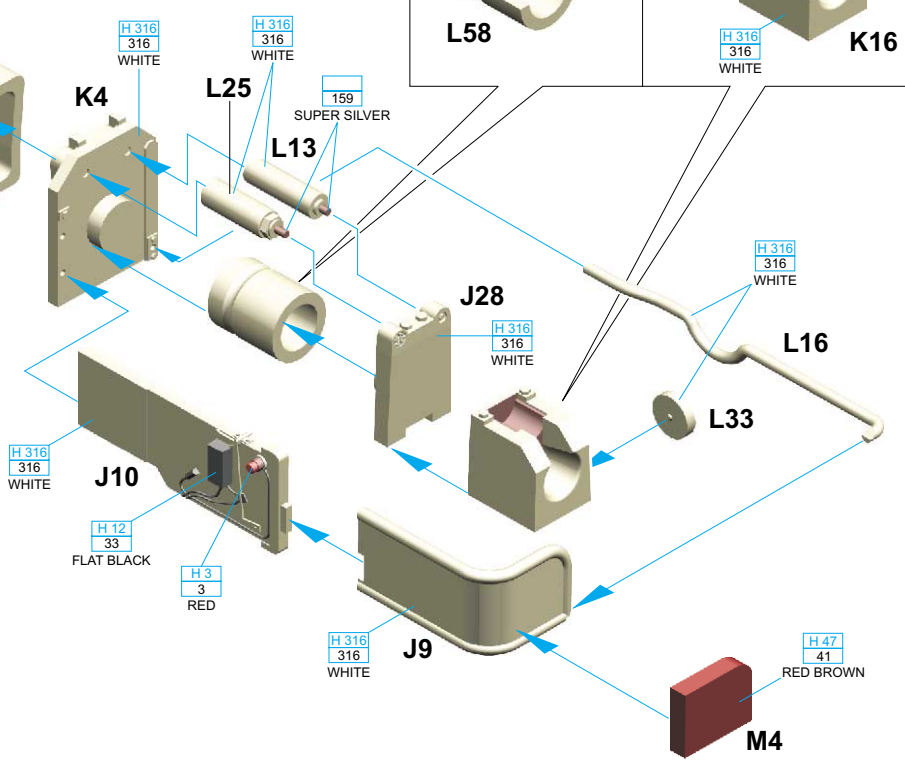
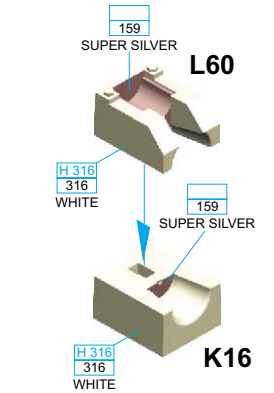
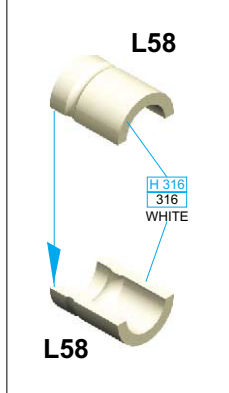
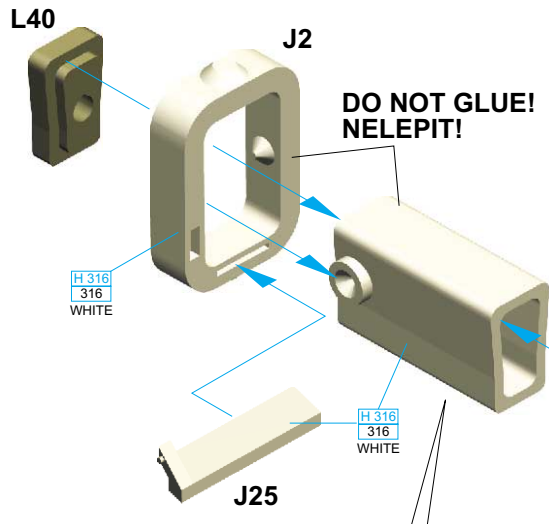

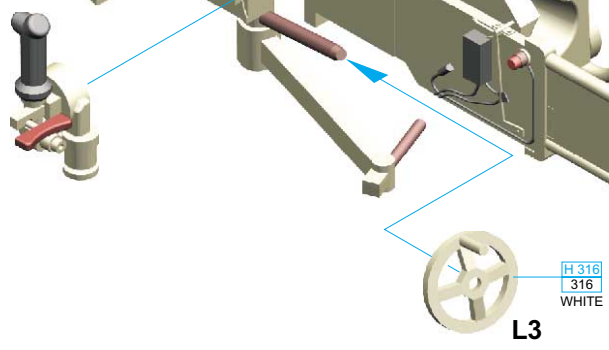
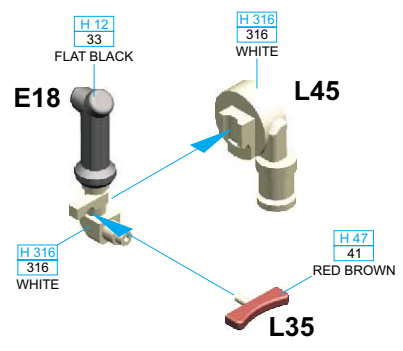
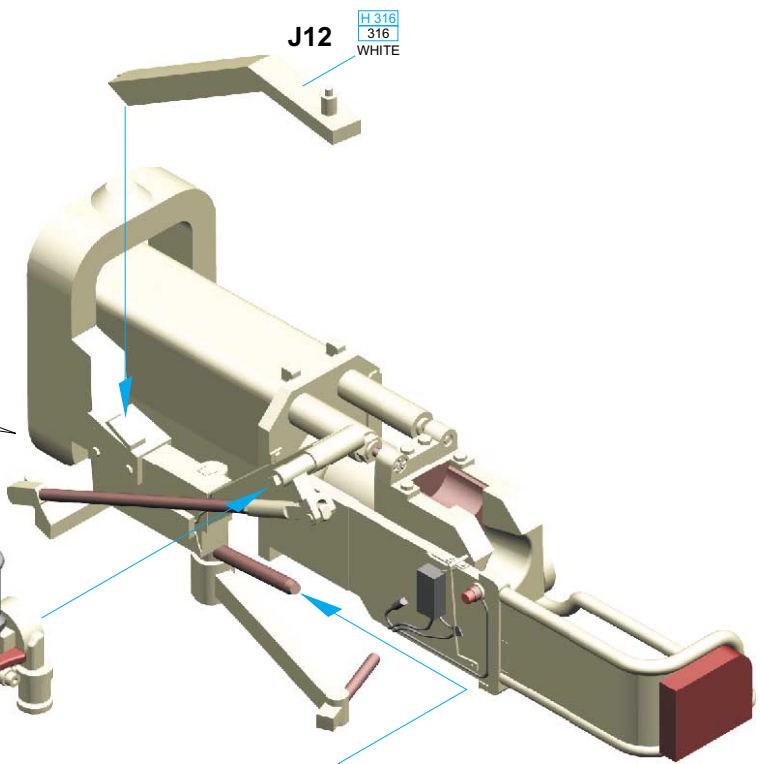
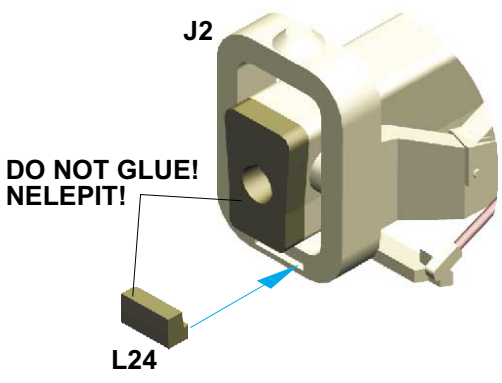
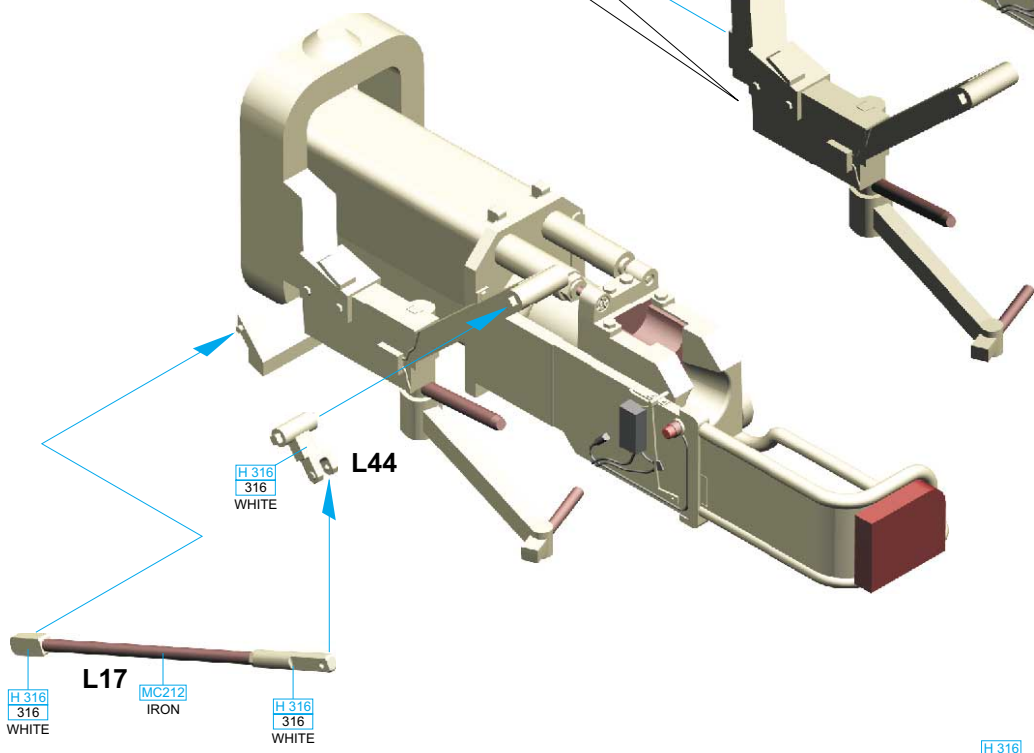
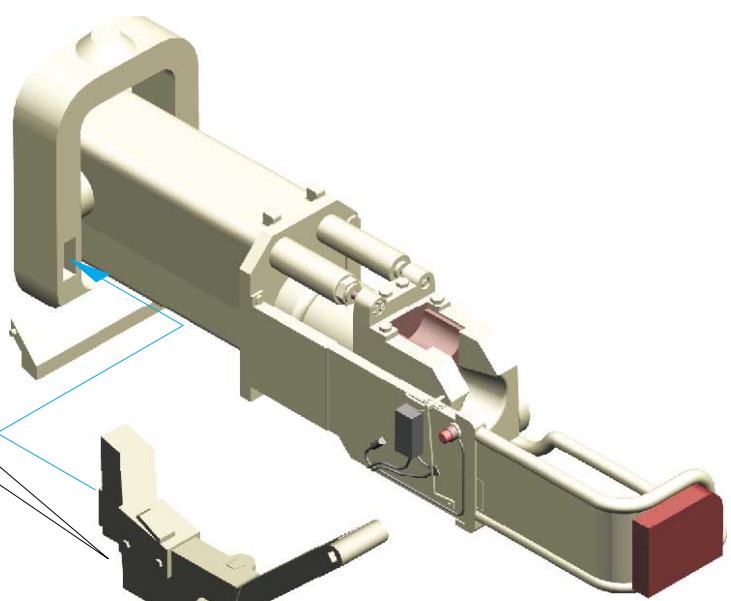
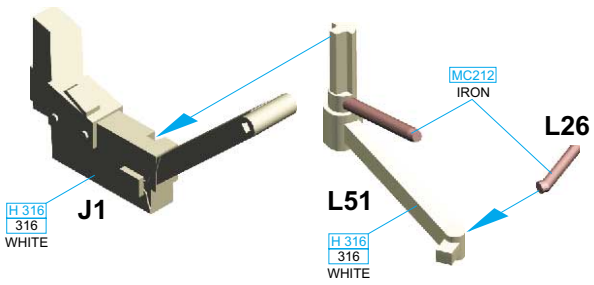

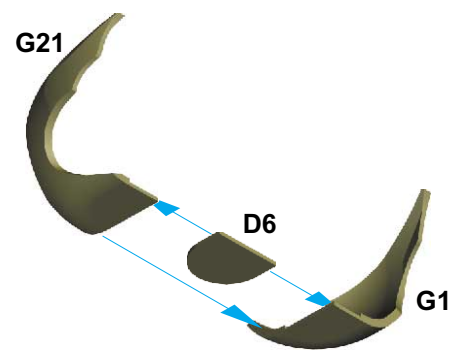
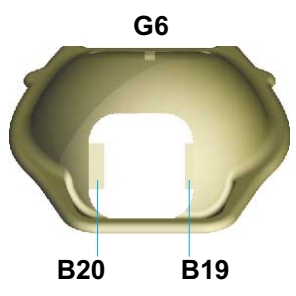
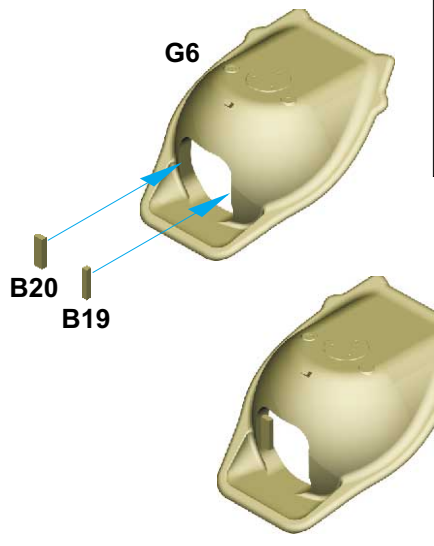
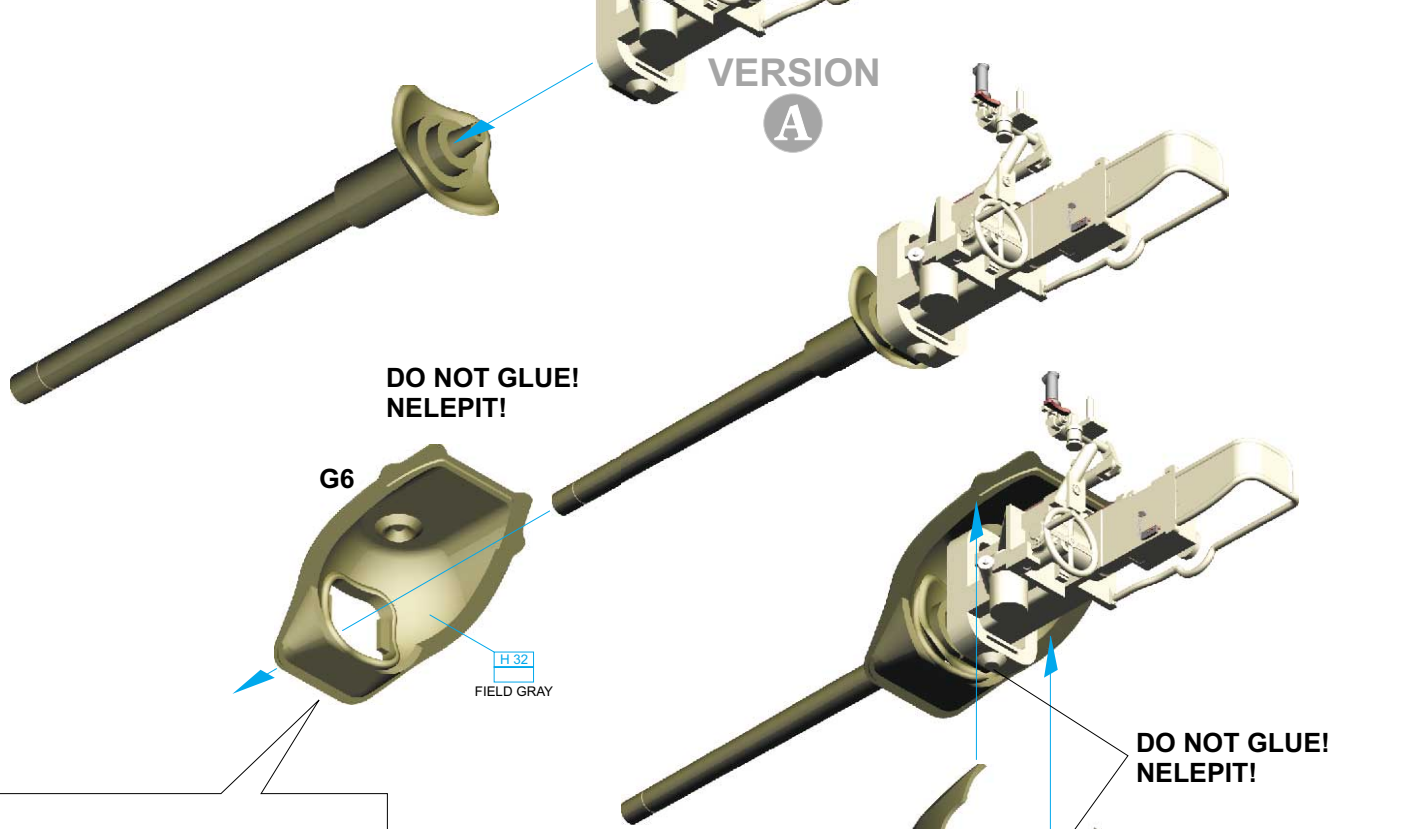
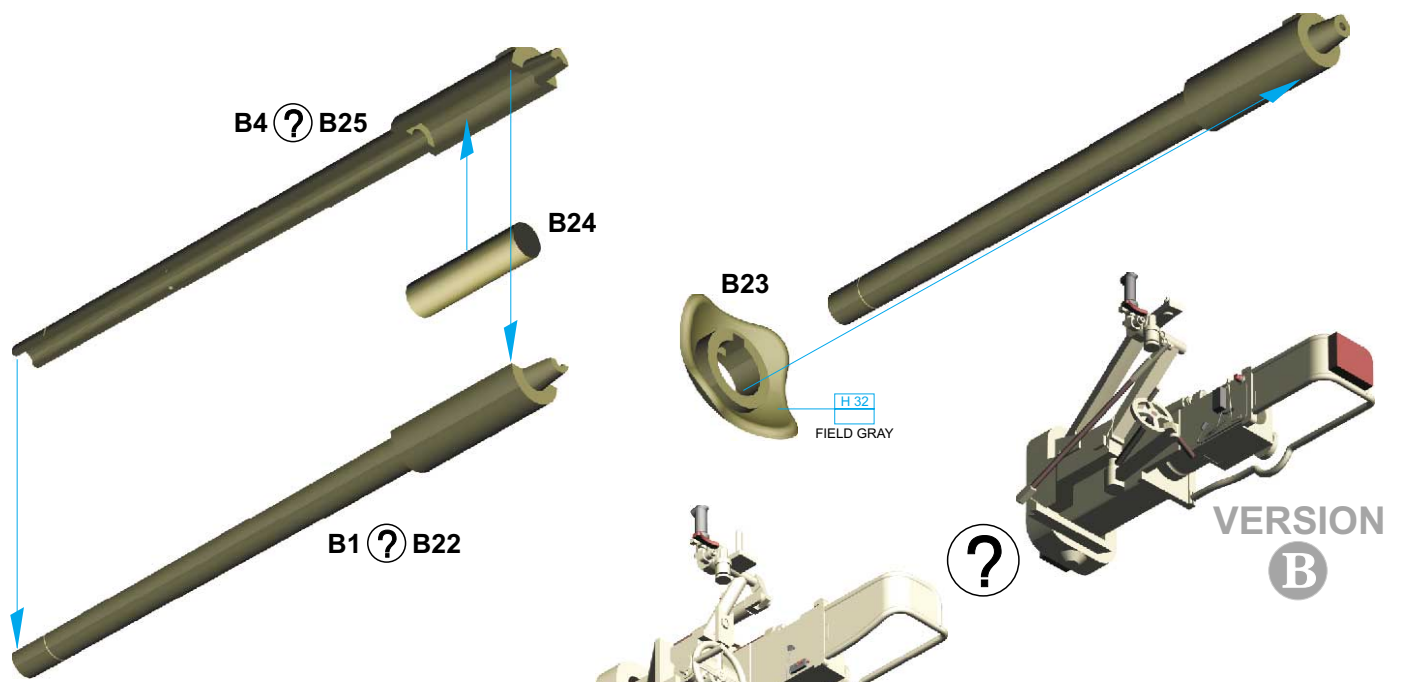

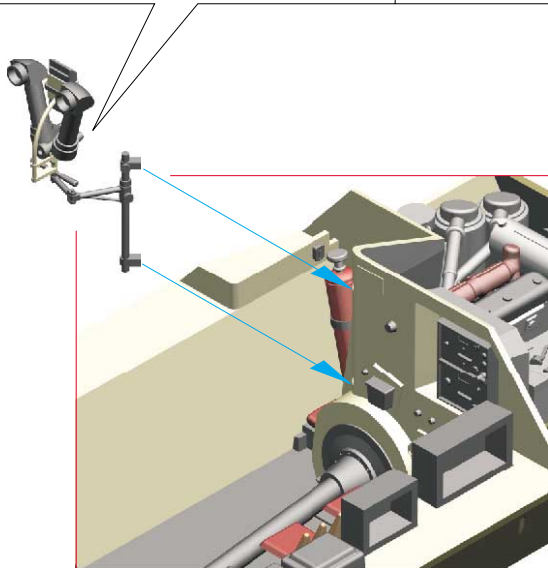
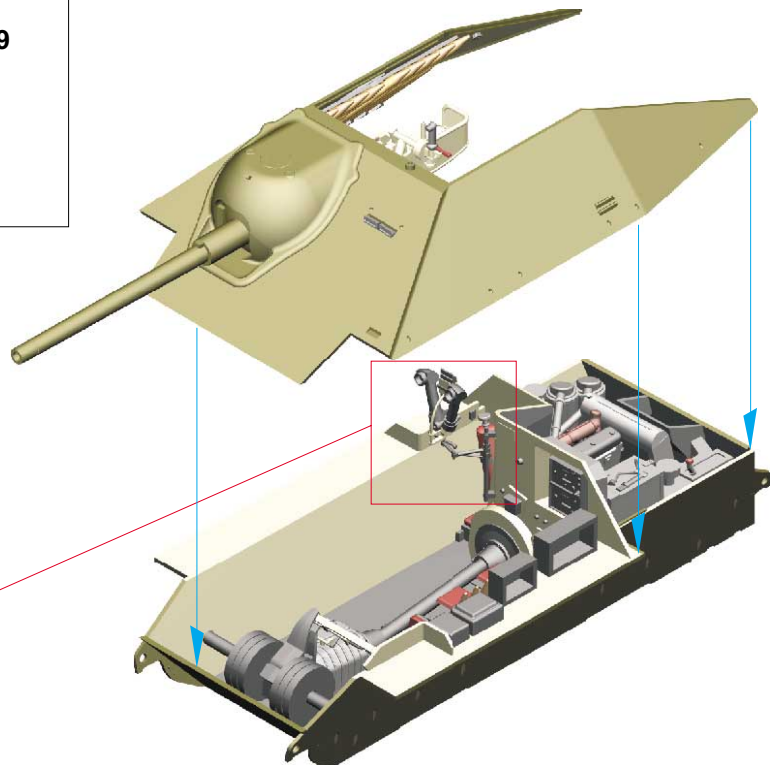
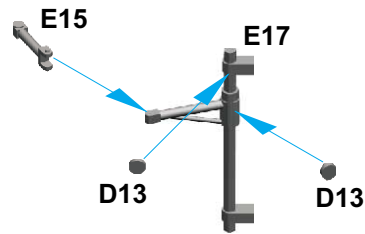
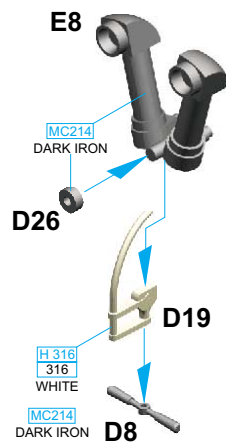
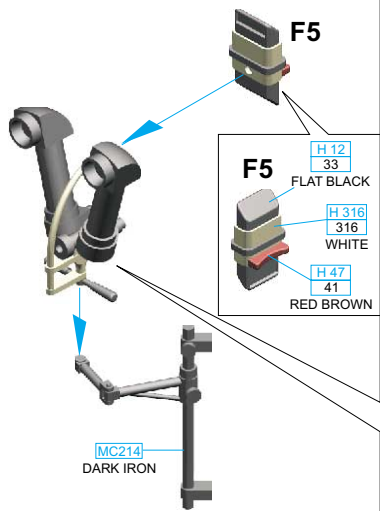
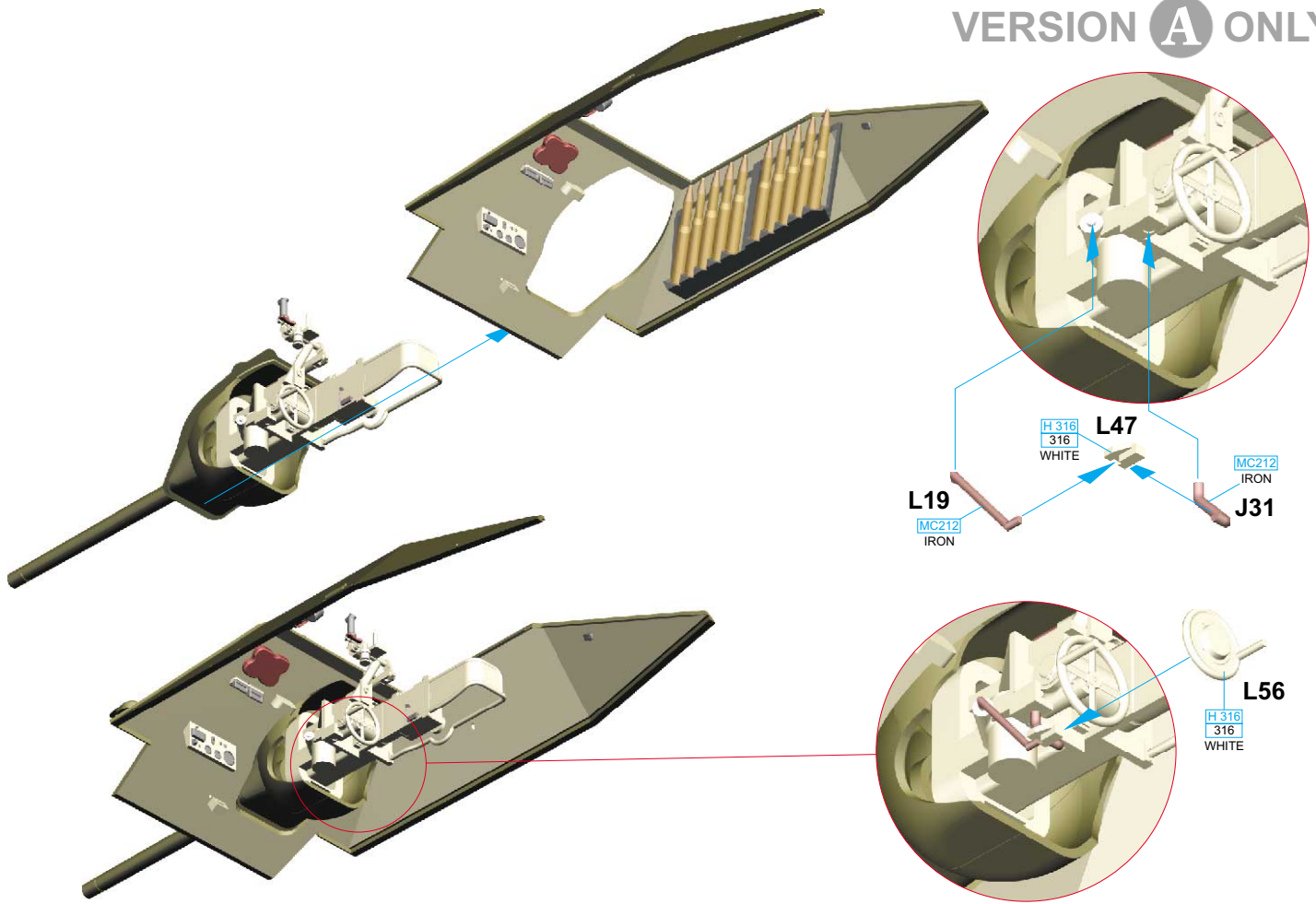

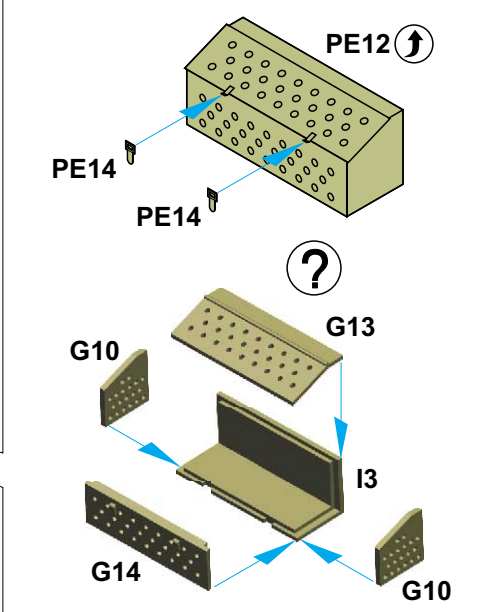
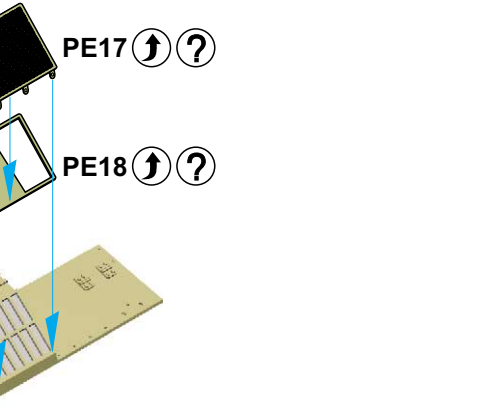
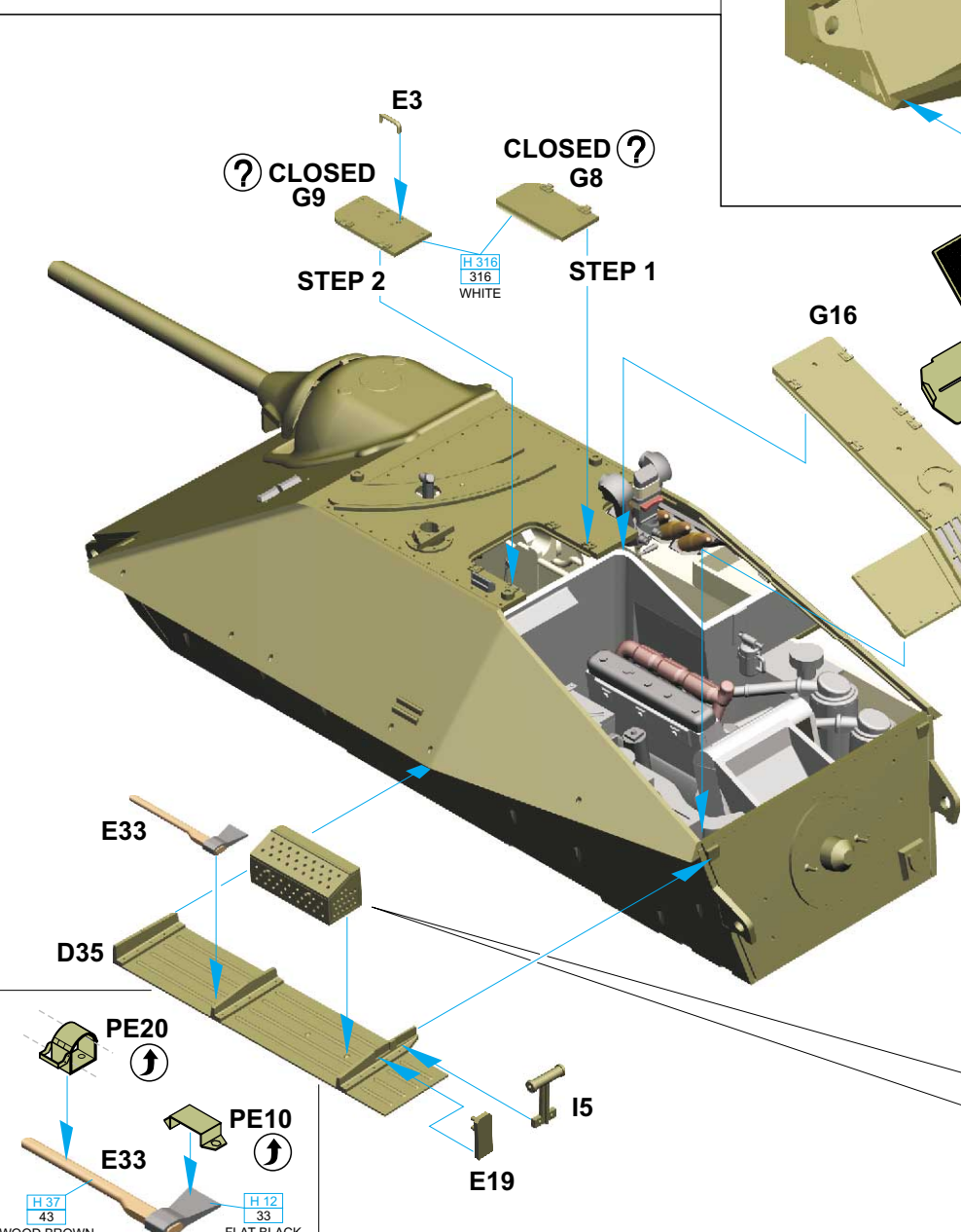
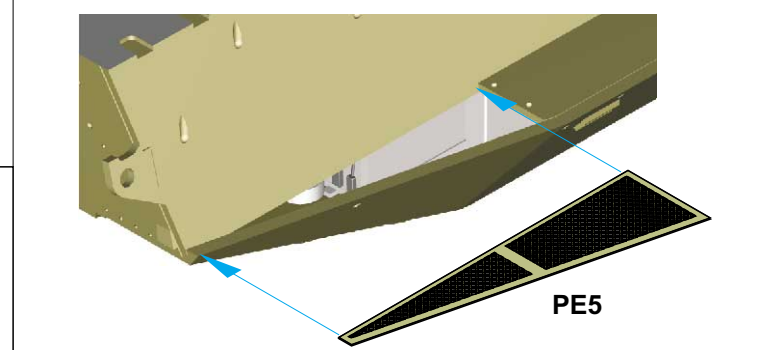
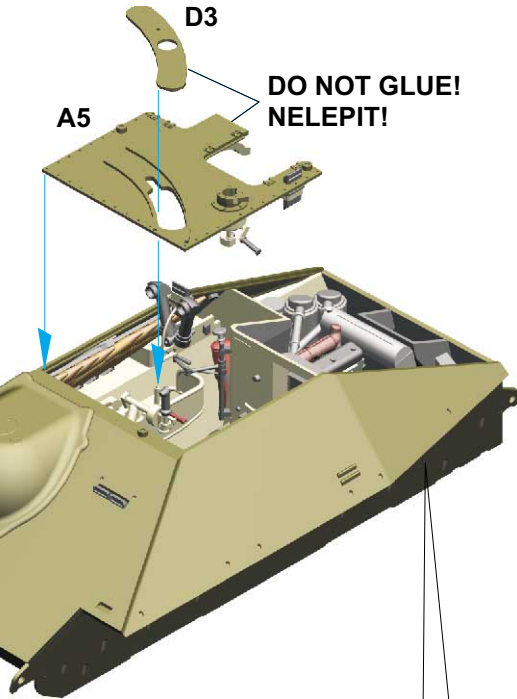
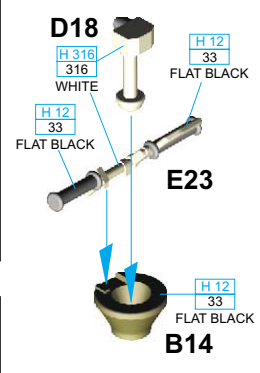
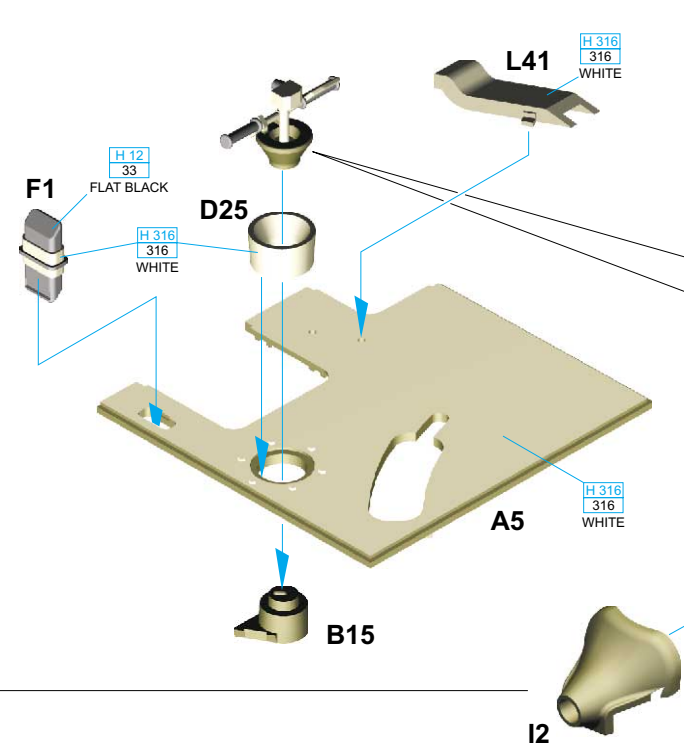

H 37 43 WOOD BROWN
H 12 33 FLAT BLACK

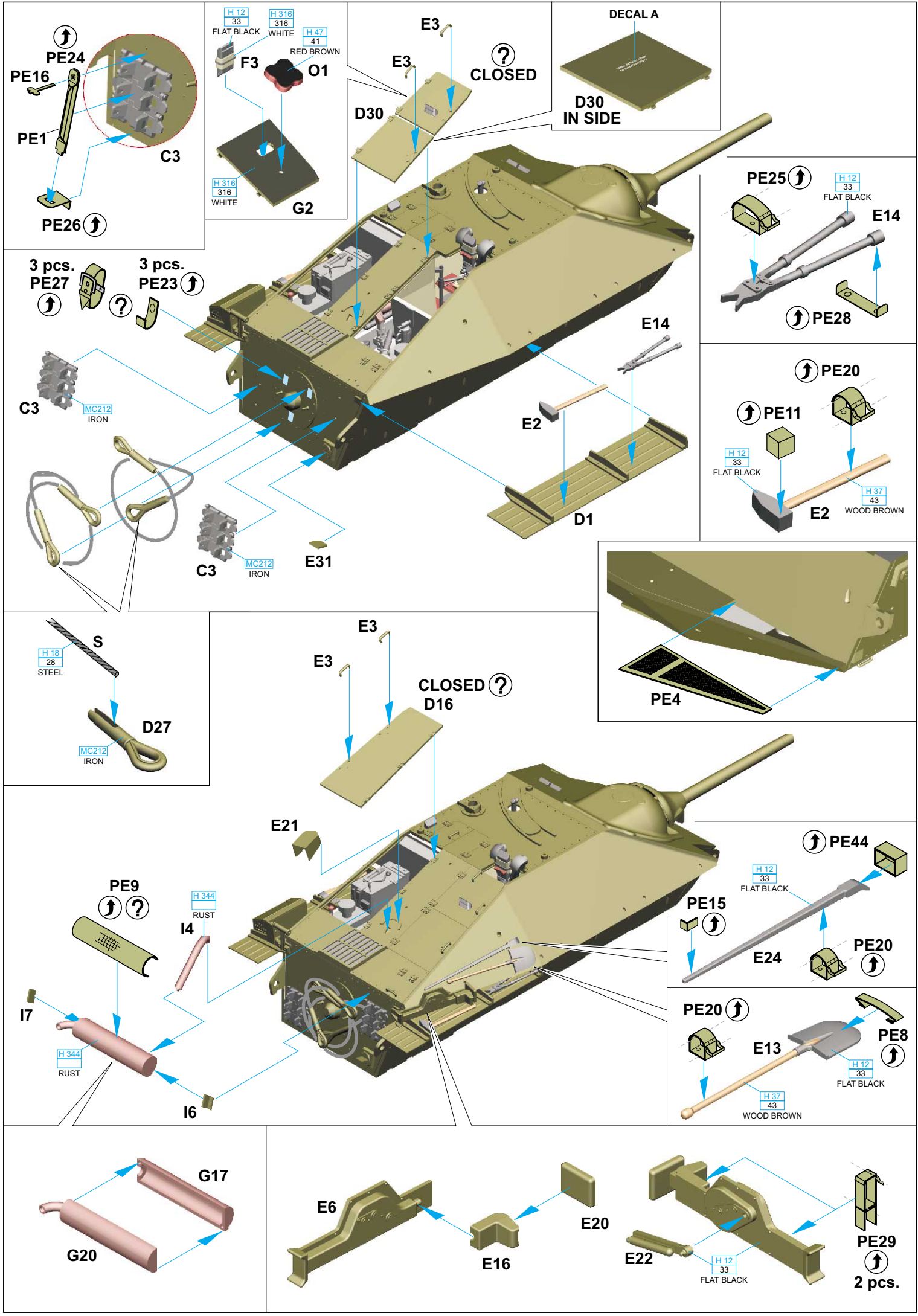

PE24 (↑) **PE16** (↑) **PE1** (↑) **PE26** (↑) **C3**

H 12 33 FLAT BLACK **H 316 316** WHITE **H 47 41** RED BROWN **F3** **O1** **H 316 316** WHITE **G2**

E3 **D30** **CLOSED** (?) **E3**

DECAL A **D30** IN SIDE

3 pcs. **PE27** (↑) (?) **PE23** (↑) (?) **C3** **MC212** IRON **E31** **C3** **MC212** IRON

PE25 (↑) **H 12 33** FLAT BLACK **E14** **PE28** (↑)

PE20 (↑) **PE11** (↑) **H 12 33** FLAT BLACK **E2** **H 37 43** WOOD BROWN

H 18 28 STEEL **S** **MC212** IRON **D27**

E3 **E3** **CLOSED** (?) **D16**

PE4

PE9 (↑) (?) **H 344** RUST **I4** **I7** **H 344** RUST **I6**

E21 **E3** **E3** **CLOSED** (?) **D16**

PE44 (↑) **H 12 33** FLAT BLACK **PE15** (↑) **E24** **PE20** (↑)

PE20 (↑) **PE20** (↑) **E13** **H 12 33** FLAT BLACK **PE8** (↑) **H 37 43** WOOD BROWN

G17 **G20**

E6 **E16** **E20**

E22 **H 12 33** FLAT BLACK **PE29** (↑) 2 pcs.

A 2 pcs.

4 pcs. **B**

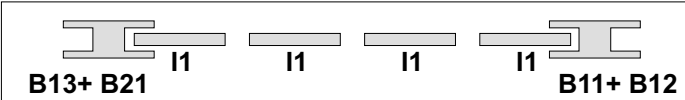
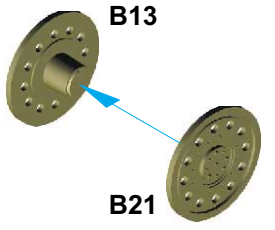
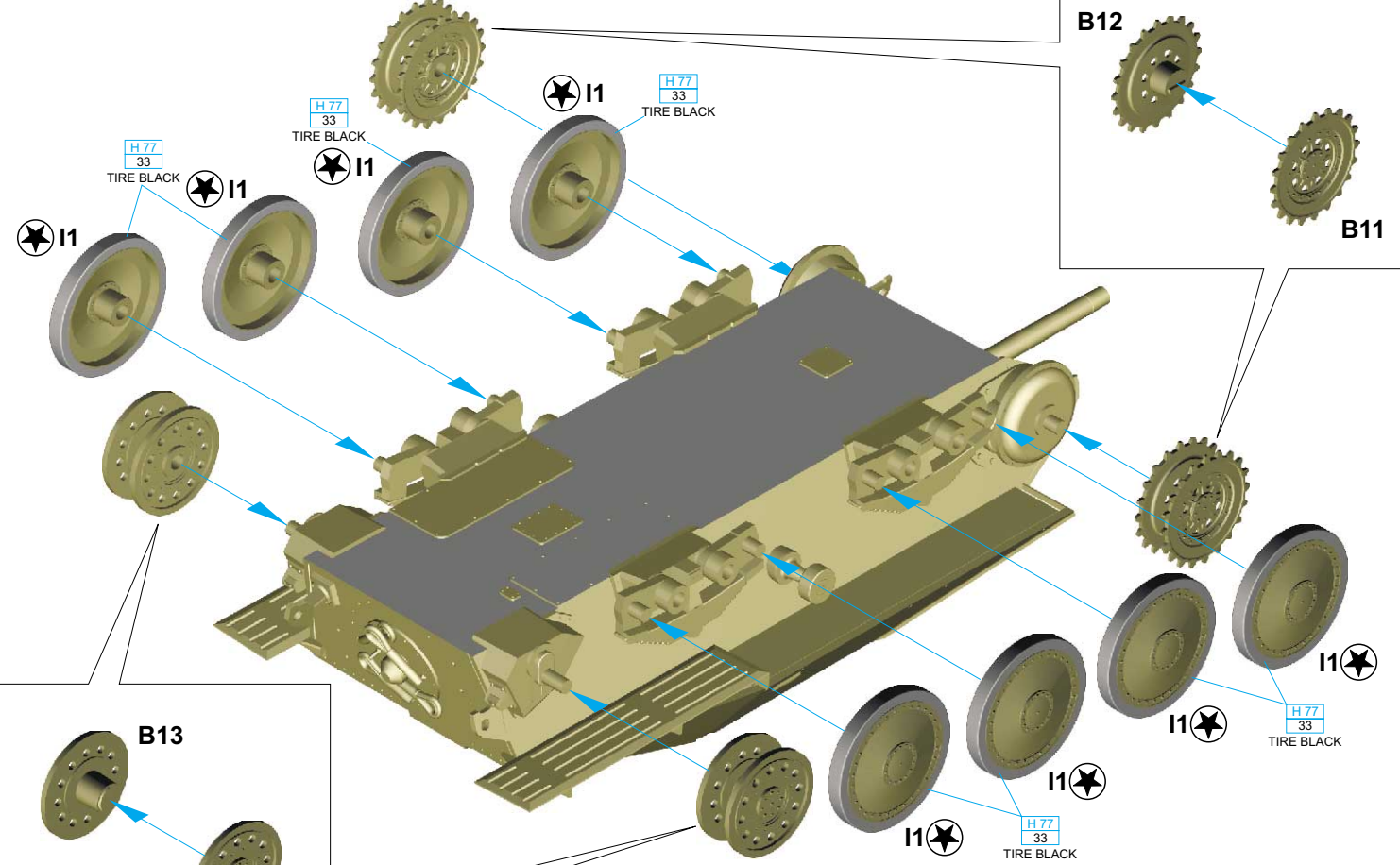
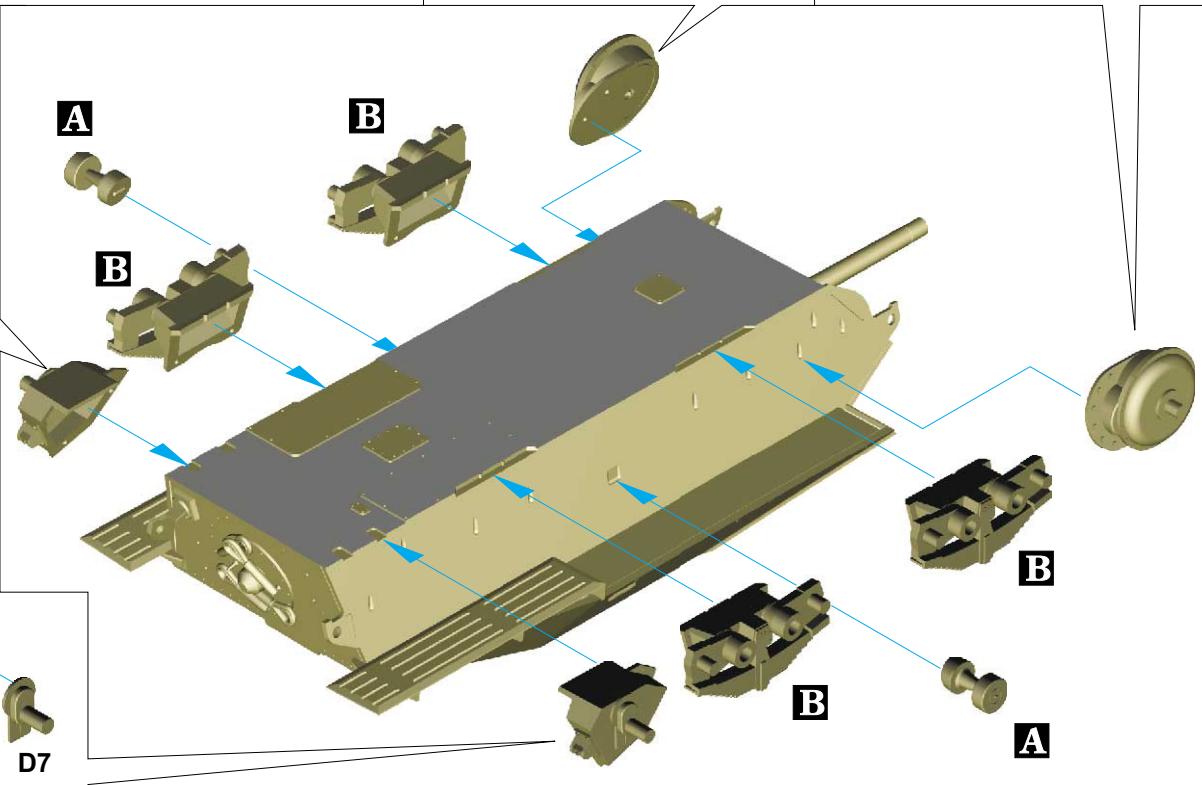
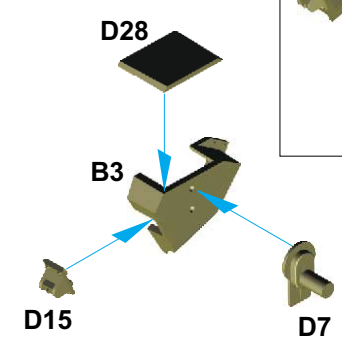
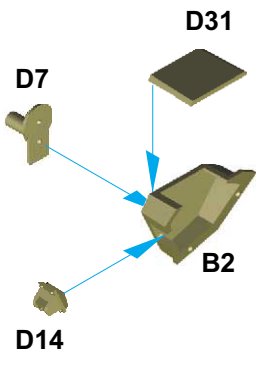
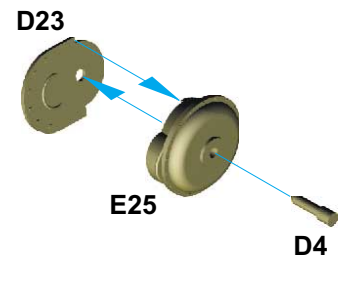
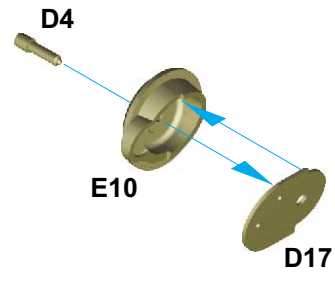
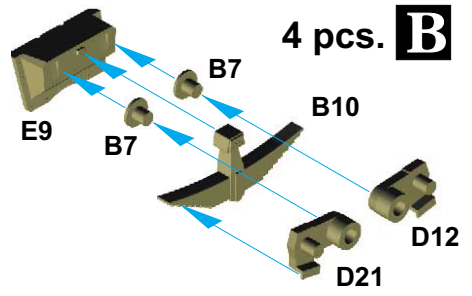
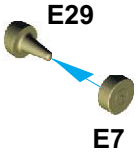

TRACK INSTALATION SESTAVA PÁSŮ

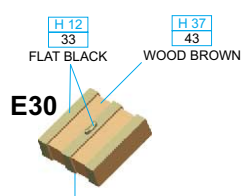
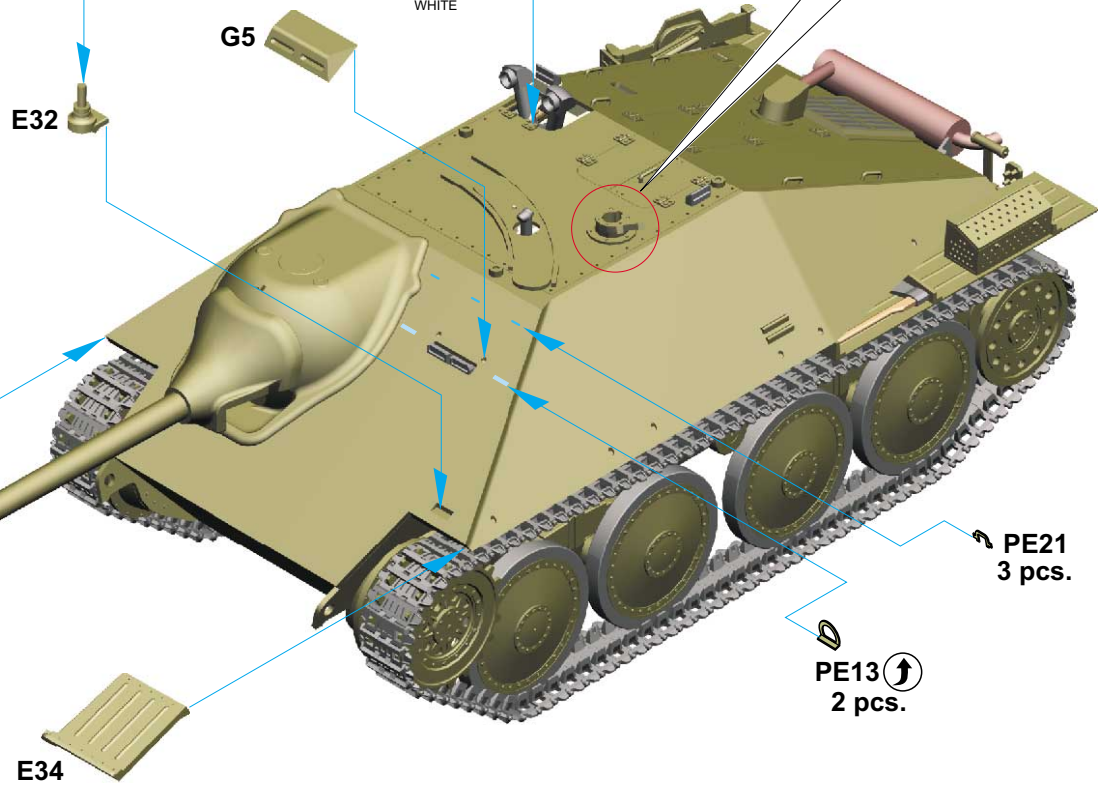
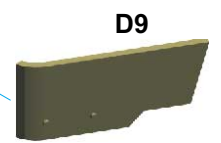
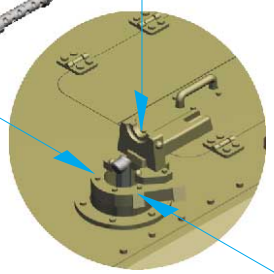
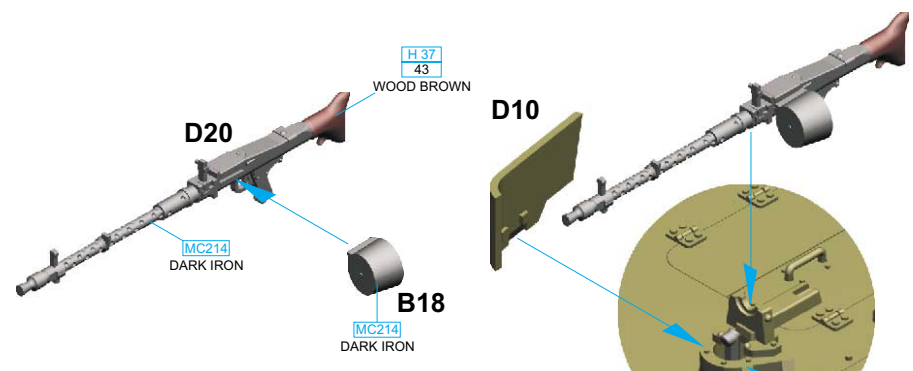
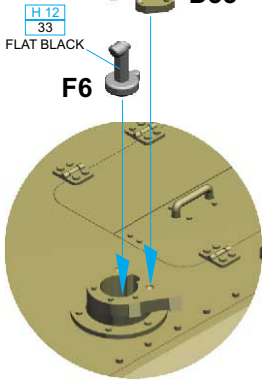
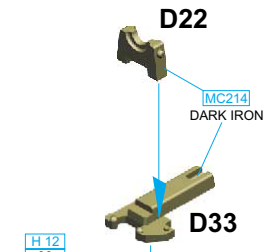
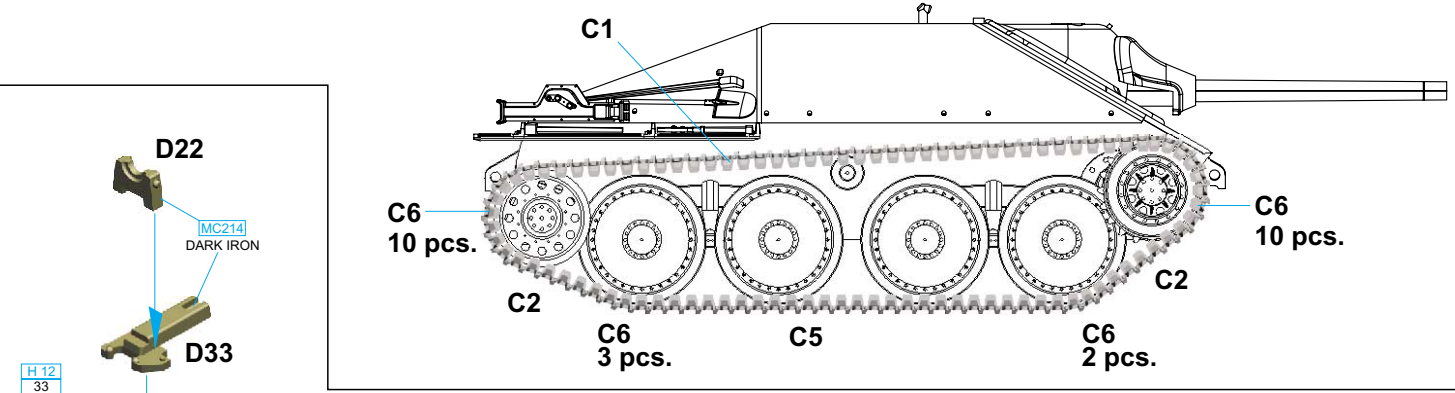
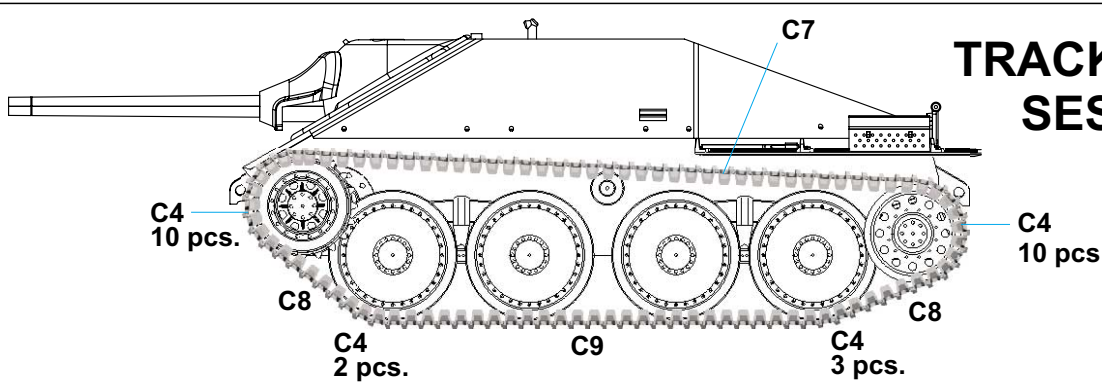

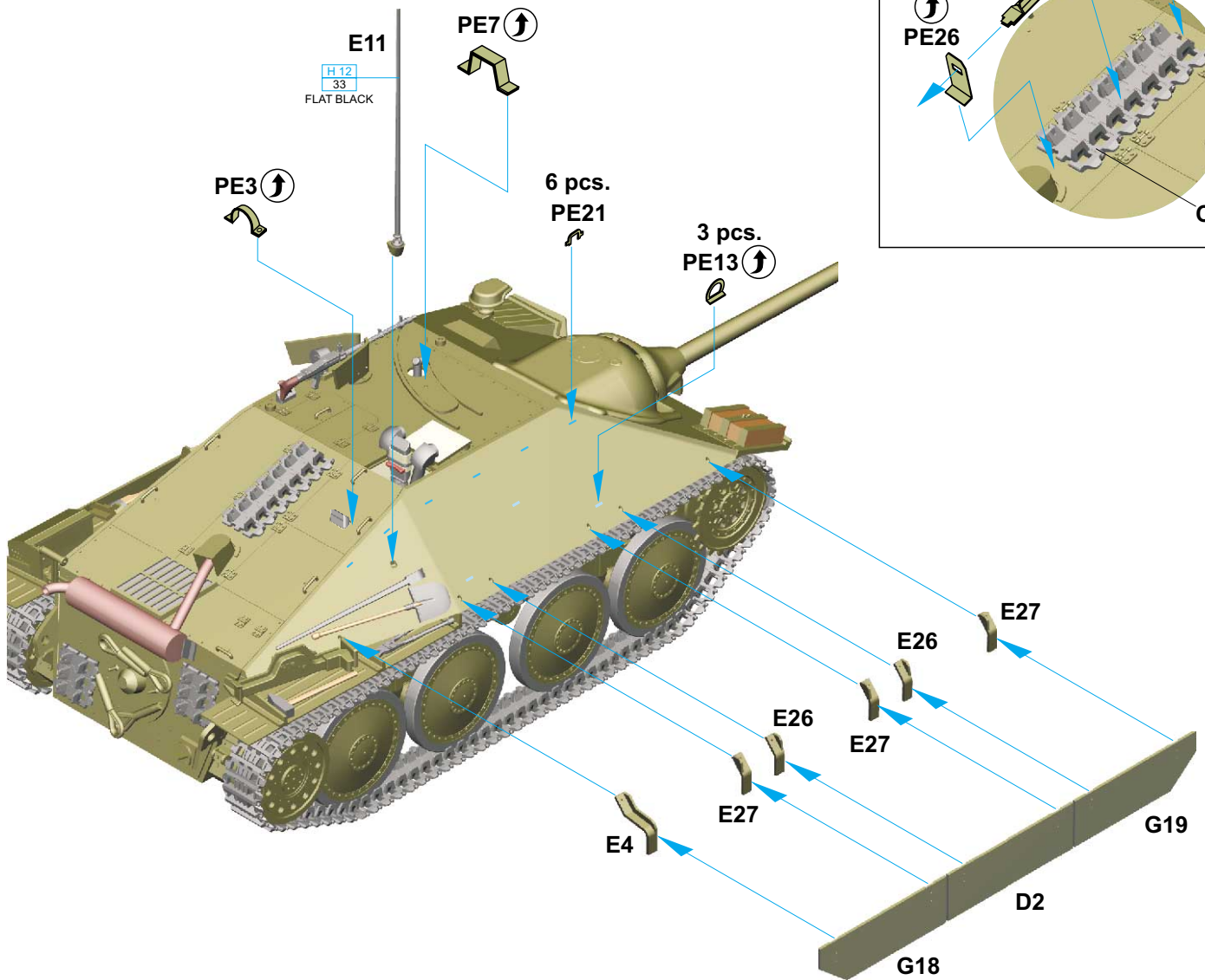
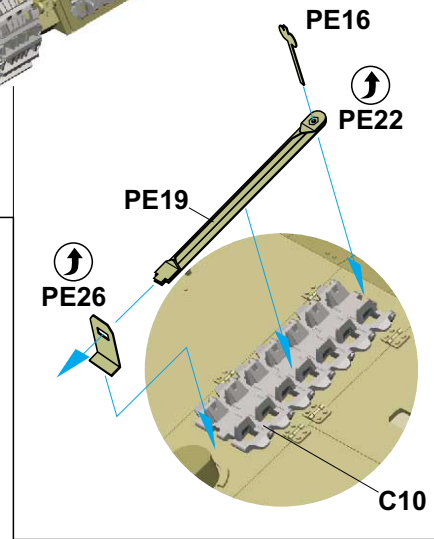
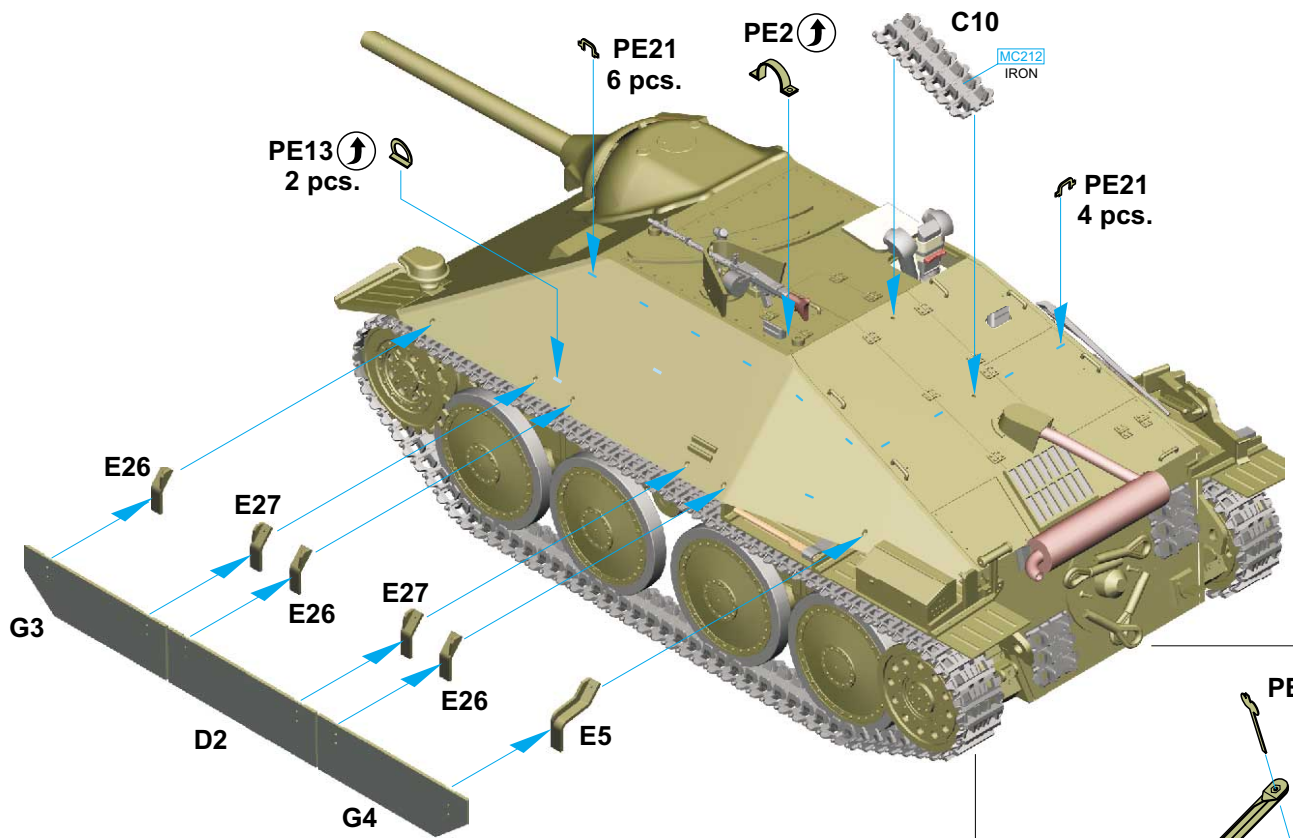

A. Pz.Jg.Abt. 743

This Hetzer was in the service of Pz.Jg.Abt.743, which converted over to the Jagdpanzer 38 Hetzer in July of 1944. By August 2, 1944, they saw combat against Polish insurgents at Warsaw. With that, it would have been one of the first Hetzers to see combat action. During this action in the vicinity of the main post office, there were two Hetzers that were engaged in the fighting. One retreated to the vicinity of Nowi Swiat, and the other was damaged and captured by the insurgents. On the 5th of August, it was towed to the courtyard of the main post office and repaired by the 14th of the same month. It then saw action in the hands of the insurgents in the same area, and it is not actually known if the vehicle was driveable or static. At the beginning of September, the main post office (Poczta Glowna) was bombed, and Chwat, as it was christened by the Poles, was buried in the rubble. There it remained until the spring of 1946, and was put on display for some time after.

The paint on this machine consisted of a factory applied coat of European Yellow (RAL 7028) with a squiggle pattern of redbrown applied at unit level. The lighter edges of this pattern is generally interpreted as being a green border, although the possibility exists that this is merely a lighter application of the redbrown color, an effect achieved during spraying. It should also be considered that the squiggle pattern may be green with edges in either redbrown or lighter, thinly applied green.

Further information on this machine can be found on the Internet at:

http://wilk.wkp.p.lodz.pl/~whatfor/pojazdy_w_powstaniu_chwat.htm

A.1

The vehicle in the service of the Pz.Jg.Abt.743

Stroj ve stavu Pz.Jg.Abt.743

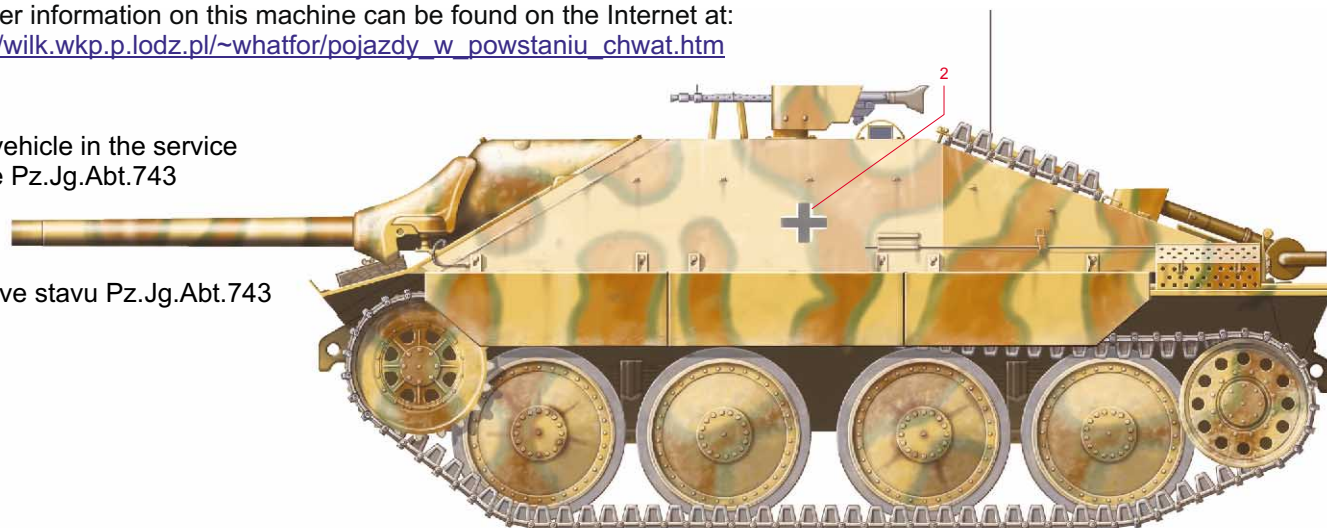

A.2

The vehicle in the Polish hands.
Stroj v rukách Polských povstalců

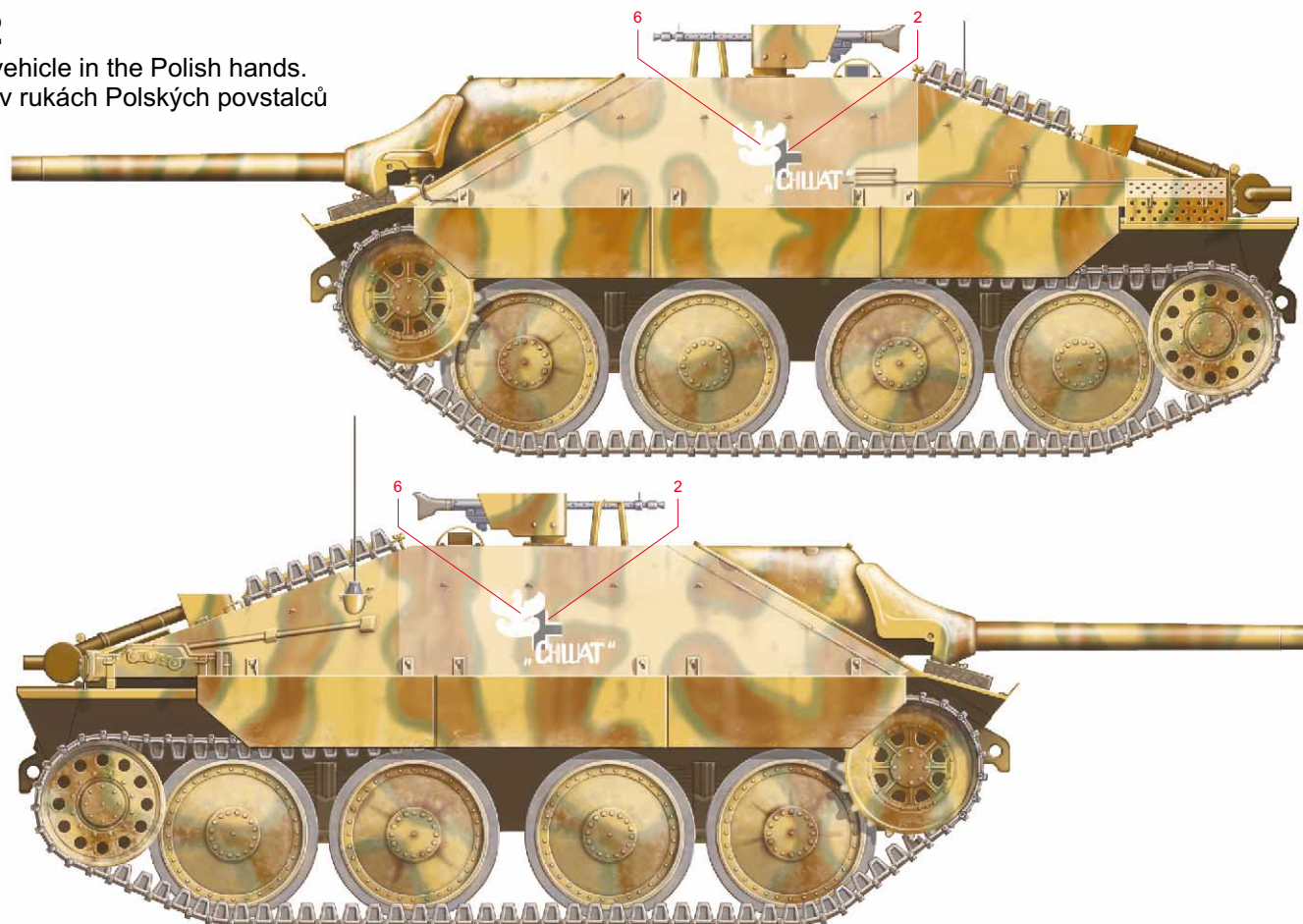

Warsaw, August 1944

Tento Hetzer náležel do stavu Pz.Jg.Abt.743, který ukončil přezbrojení na nové Jagdpanzery 38 28.července 1944. Již 2.srpna 1944 ráno se zúčastnil bojů proti polským povstalcům ve Varšavě. Stal se tak jedním z prvních bojově nasazených Hetzerů vůbec. Při této akci v oblasti Hlavní Pošty byly použity dva Hetzery, jeden z nich ustoupil zpět do oblasti Nowi Świat, druhý byl poškozen a ukořistěn povstalcí. 5.srpna ho odtáhli na nádvoří Hlavní Pošty (Poczta Glówna), a do 14.srpna ho opravili. Stroj potom bojoval u Hlavní Pošty, většinou jako součást barikády, a není jisté, zda byl pojezdny. Začátkem září byla Hlavní Pošta bombardována, a „Chwat“, jak byl stroj povstalcí pojmenován, byl zavalen troskami budovy. Pod nimi zůstal až do jara 1946, kdy byl vyproštěn a nějakou dobu vystavován.

Základní zbarvení stroje evropskou žlutou (RAL 7028) bylo u jednotky doplněno skvrnami červenohnědé barvy. Odlišná barva okrajů skvrn je interpretována jako zelený lem, může ovšem jít i o světlejší, méně kryjící okraj červenohnědé, což je častý jev při aplikaci barvy stříkácí pistolí. Není ovšem vyloučeno, že skvrny byly ve skutečnosti zelené, s červenohnědým lemem, nebo světlejším zeleným lemem.

Další informace o tomto stroji včetně řady unikátních fotografií najdete na internetové stránce

http://wilk.wkp.p.lodz.pl/~whatfor/pojazdy_w_powstaniu_chwat.htm

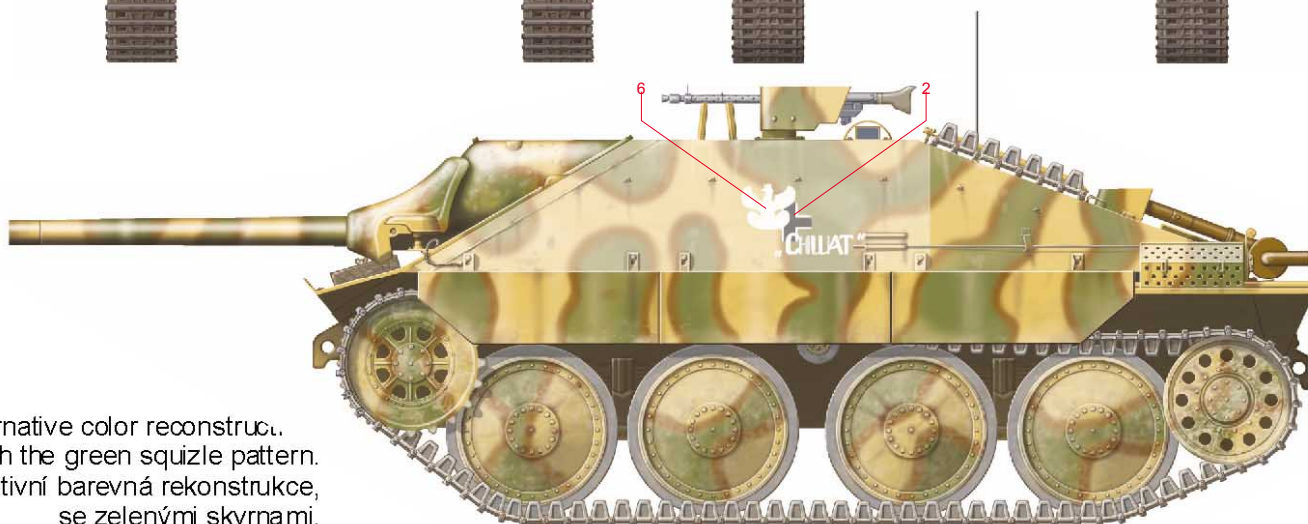
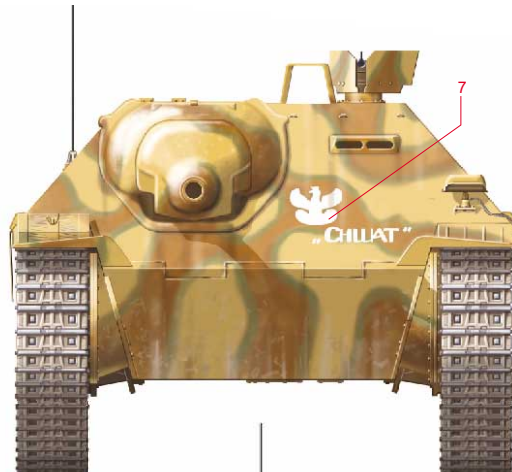
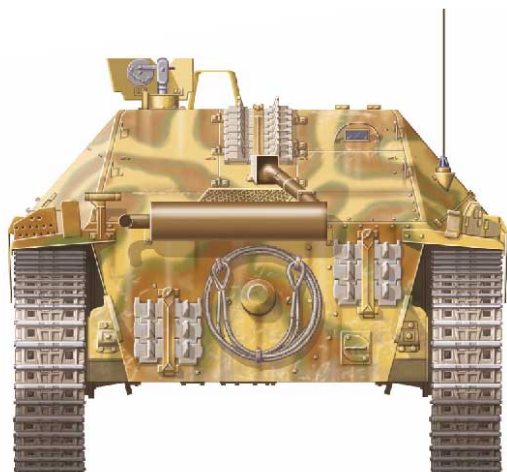
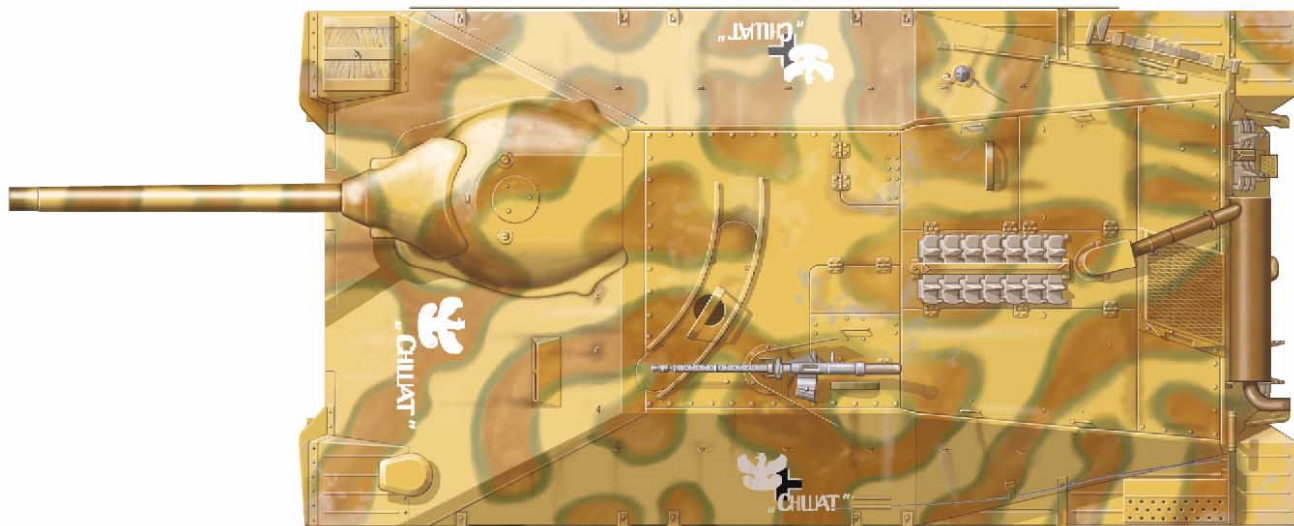

Alternative color reconstruction
with the green sizzle pattern.
Alternativní barevná rekonstrukce,
se zelenými skvrnami.

SANDY YELLOW H79
39

OLIVE DRAB H78
38

RED BROWN H47
41

B. Pz.Jg.Abt. 97, 97. Jäger Division

This machine survived the war. In April, 1945, it evidentially took part in the fighting in Upper Silesia and for the town of Ostrava with the 97th PzJgAbt supported by the 97th Jäger Division. In May, 1945, it was dislocated to a stockpile of captured war booty in a field at Nove Mesto in Moravia. It carried a unit level applied camouflage scheme over the factory applied European Yellow (RAL 7028). This consisted of irregular fields and squiggles of (probably) olive green and redbrown colors. Other sources interpret the squiggle pattern to be green bordered with redbrown, and it can't be ruled out that these patterns are in just one of these two colors.

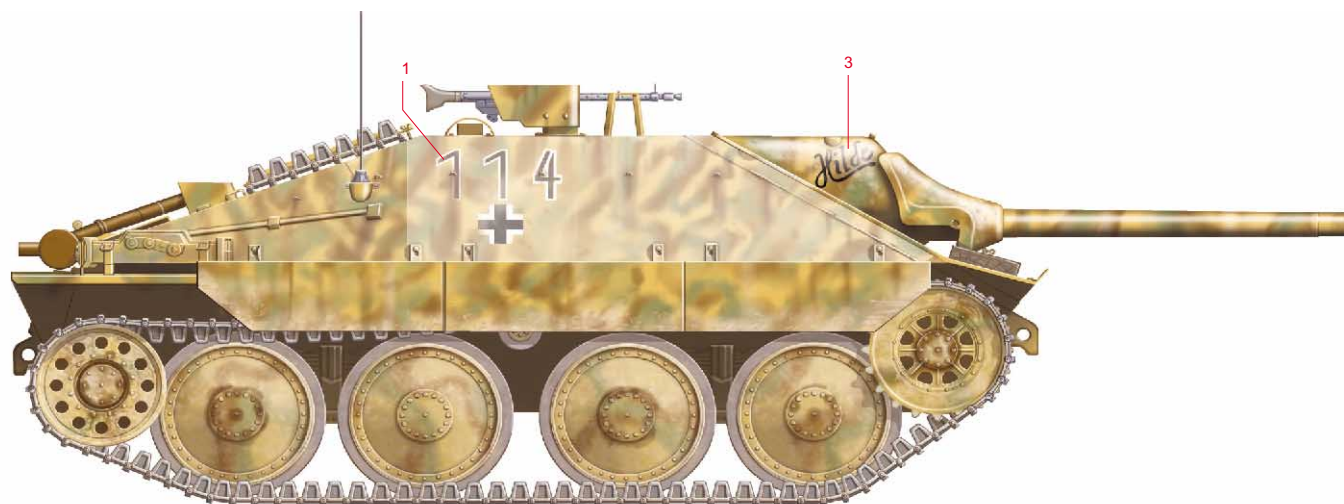
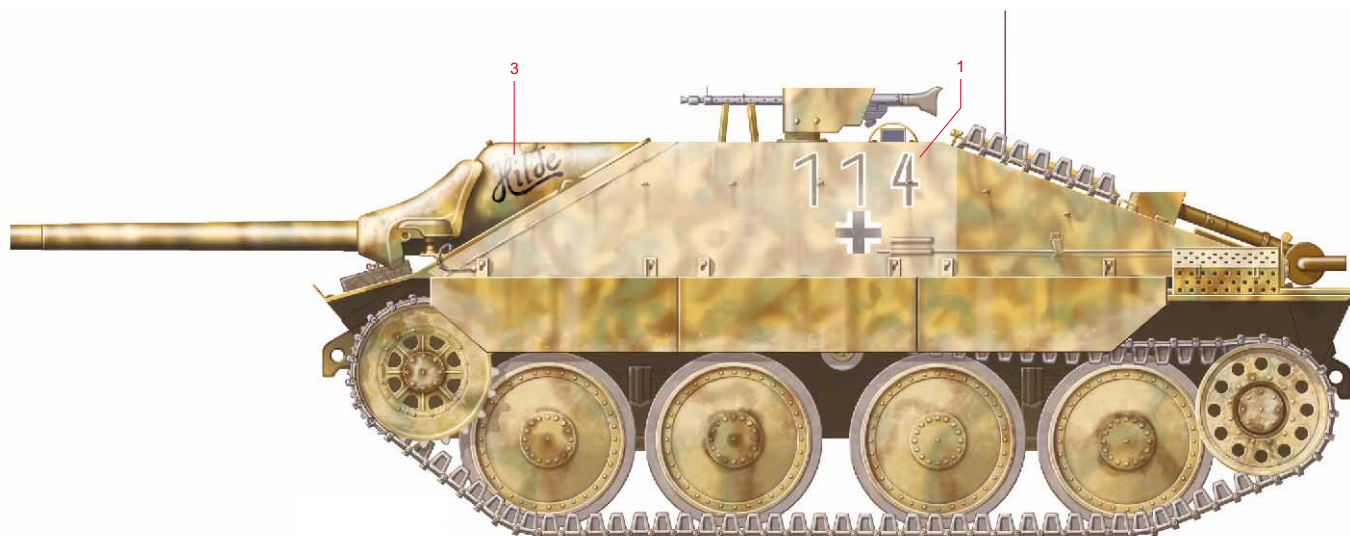

SANDY YELLOW H79
39

OLIVE DRAB H78
38

RED BROWN H47
41

Czechoslovakia, May 1945

Tento stroj přežil až do konce války. V dubnu 1945 se pravděpodobně zúčastnil obraných bojů v Horním Slezsku a na přístupech k Ostravě. V květnu 1945 se s několika dalšími Hetzery nacházel na shromaždišti kořistní techniky na poli u Nového Města na Moravě. Nesl kamufláž aplikovanou u jednotky, přes původní tovární nátěr evropskou žlutou (RAL 7028) měl nastříkané pruhy a skvrny (pravděpodobně) olivové zelené barvy a hnědočervené barvy. Jiná interpretace hovoří o zelených skvrnách, lemovaných červenohnědou barvou, může ovšem jít i o skvrny pouze jedné z těchto barev.

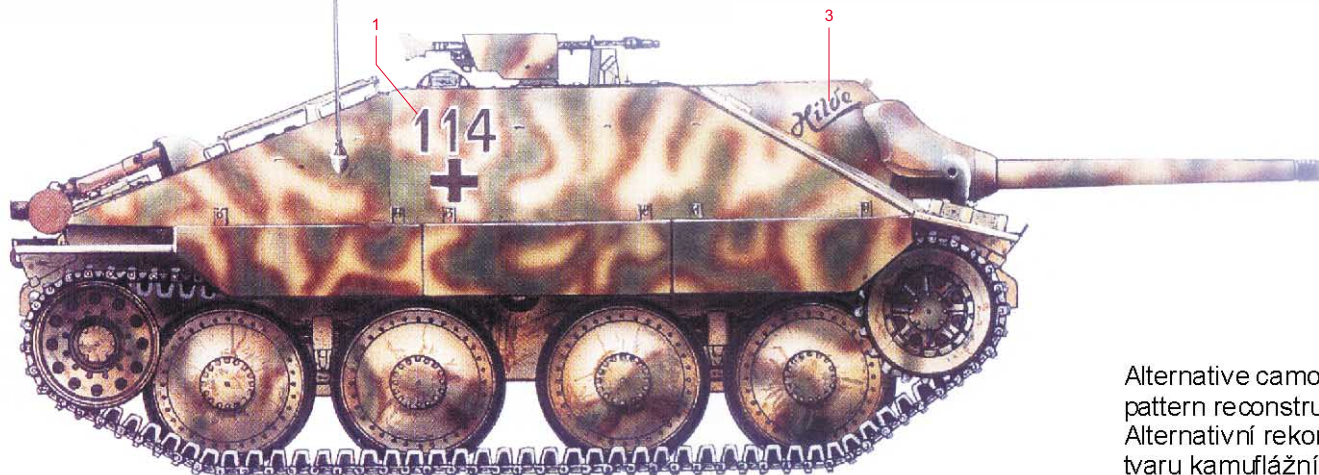
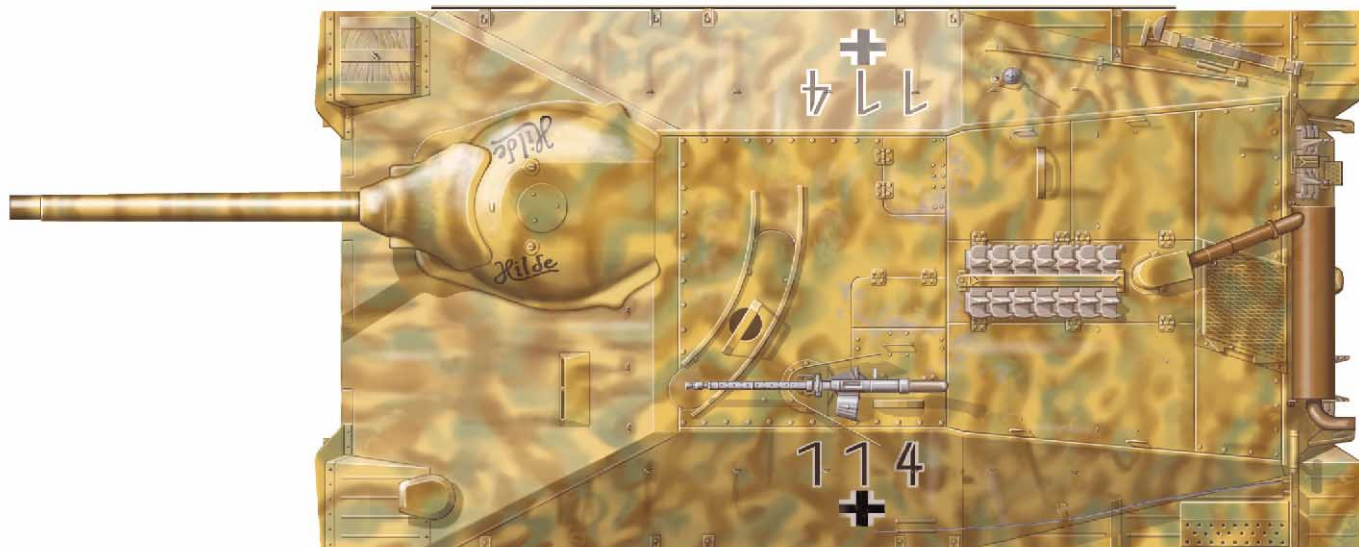

Alternative camouflage pattern reconstruction.
Alternativní rekonstrukce tvaru kamuflážních skvrn.

A>

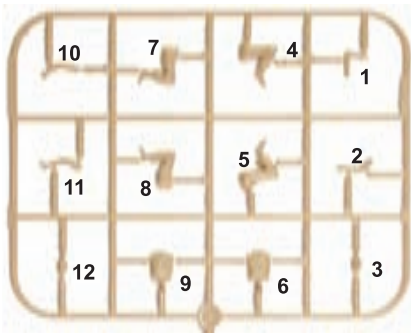

B>

