

ANTI GLARE
PANEL:
FLAT BLACK

RED AND WHITE
STRIPES

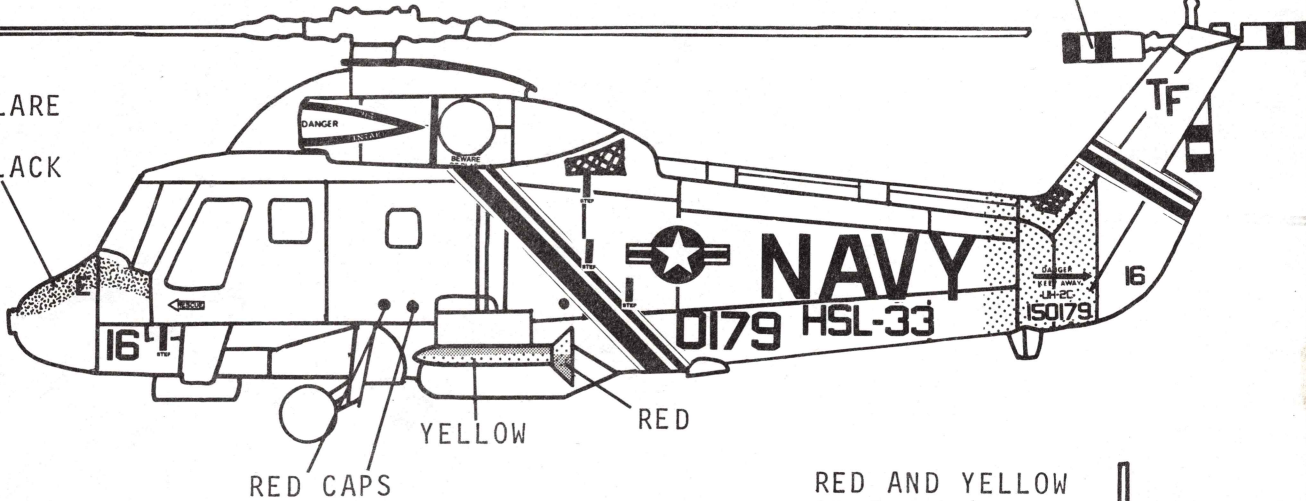

KAMAN SH-2F 150179, HSL-33 NAS LEMOORE MAY, 1980. HELICOPTER IS ENGINE GRAY FSC#16081. HORIZONTAL STABILIZERS AND BRACES HAVE ALTERNATING THIN RED AND YELLOW STRIPES. RADOME UNDER NOSE IS NATURAL FIBERGLASS COLOR (TAN). INSIGNIA ON ROTOR HOUSING ALWAYS APPEARS UPSIDE DOWN.

RED AND YELLOW
STRIPES

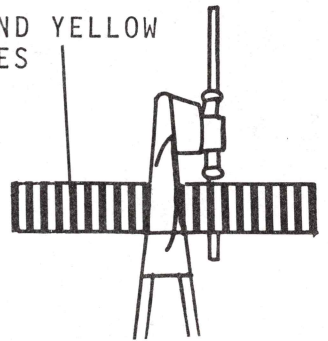

ANTI GLARE
PANEL:
FLAT BLACK

RED AND WHITE
STRIPES

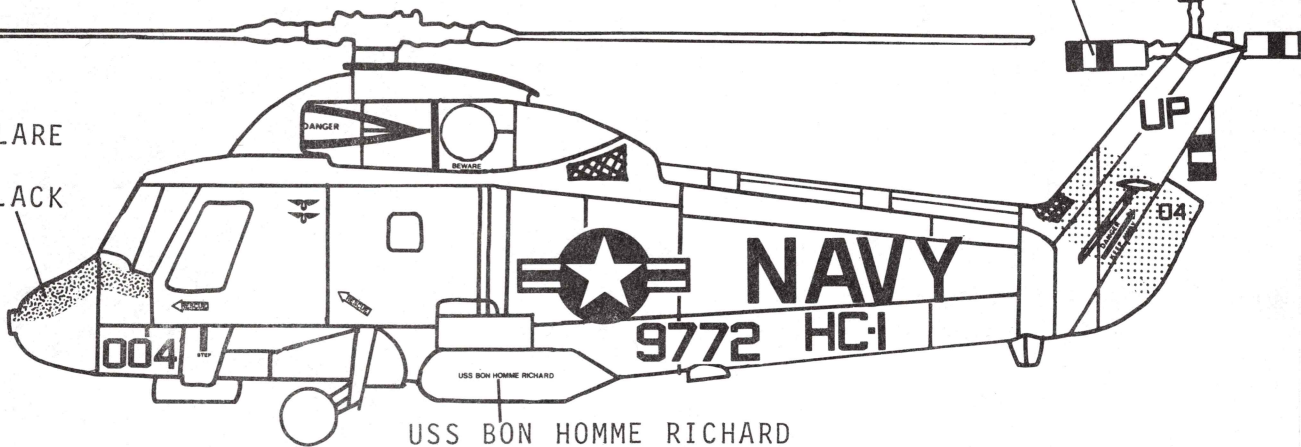

USS BON HOMME RICHARD

KAMAN SH-2F USS BON HOMME RICHARD HC-1 HELICOPTER COMBAT SUPPORT SQUADRON ONE: COMMISSIONED IN 1949 AS HU-1 THE FIRST OPERATIONAL HELICOPTER SQUADRON IN THE NAVY. IN OVER 26 YEARS OF OUTSTANDING SERVICE HC-1 HAS RESCUED OVER 1400 PEOPLE AND HAS RECEIVED MANY UNIT COMMENDATIONS FOR ITS EXCEPTIONAL WORK. OVERALL HELICOPTER COLOR IS FSC#16081. HORIZONTAL STABILIZERS AND BRACES HAVE ALTERNATING RED AND YELLOW STRIPES.

RED AND YELLOW
STRIPES

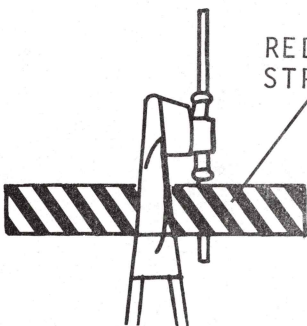

ROTOR BLADE

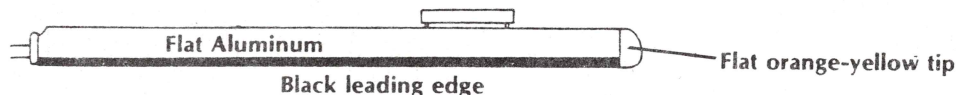

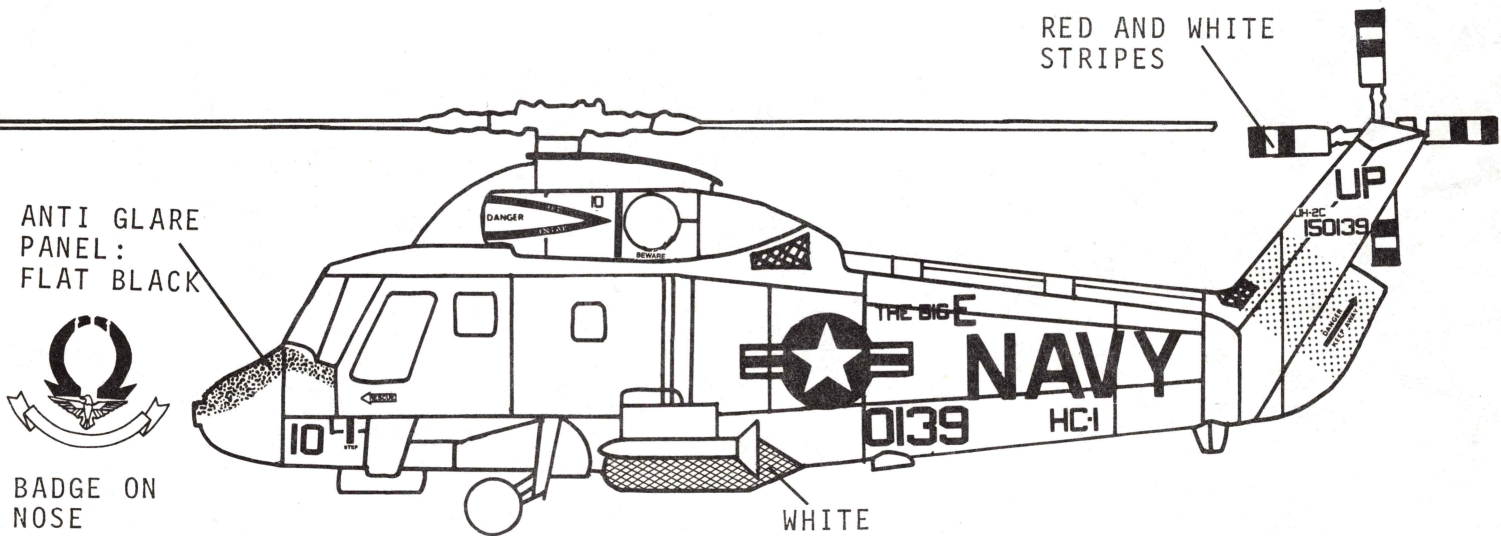

KAMAN UH-2C 150139 HC-1 U.S.S. ENTERPRISE, 1965. HELICOPTER IS OVERALL ENGINE GRAY FSC#16081. HORIZONTAL STABILIZERS AND BRACES HAVE ALTERNATING THIN RED AND YELLOW STRIPES. EXTERNAL FUEL TANKS ARE WHITE. INSIGNIA ON ROTOR HOUSING ALWAYS APPEARS UPSIDE DOWN.

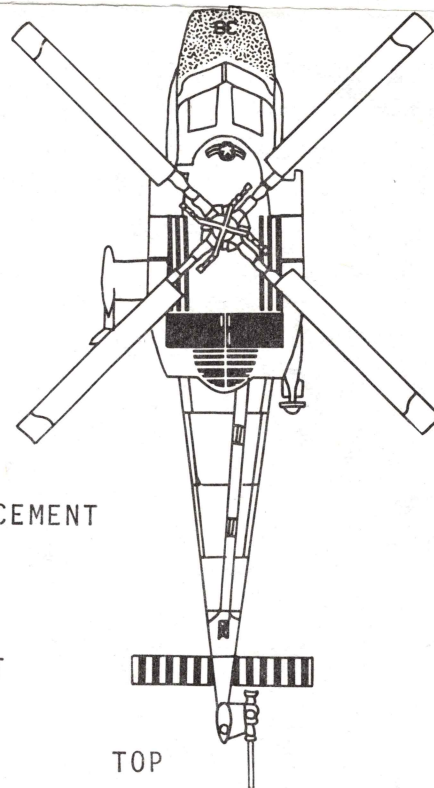
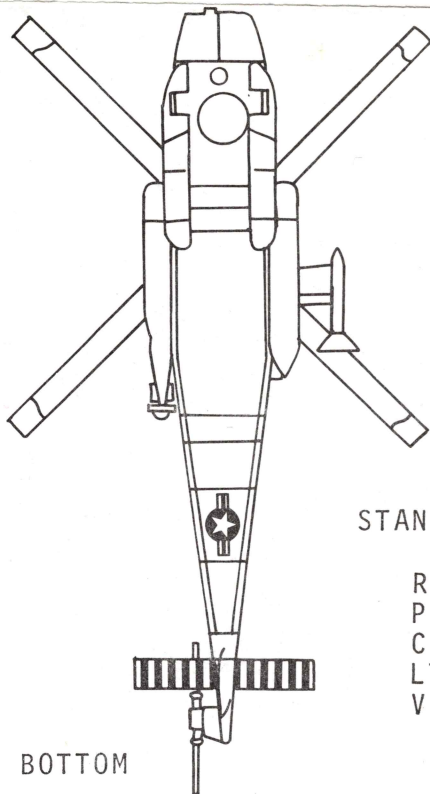

STANDARD DECAL PLACEMENT

RESEARCH BY
 PETE HARLEM
 CHELUN HUANG
 LT. BILL HOCKETT
 VIA DON GARRETT

TOP SURFACE (22.500)

BOTTOM SURFACE (22.500)

E E



0139

16

TF

10

TF

16

0139

UH-1C
150179

UH-1C
150179

UP

UP

10

UP

UP

UH-1C
150139

UH-1C
150139



004

THE BIG E

10

10

THE BIG E

004



HC-1

HSL-33

16

HSL-33

HC-1



HC-1

0179

04

04

0179

HC-1

9772



10



9772



BEWARE OF BLAST



BEWARE OF BLAST



BEWARE OF BLAST



BEWARE OF BLAST

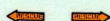

→ DANGER

← DANGER

→ DANGER

← DANGER



NAVY

→ DANGER

← DANGER

→ DANGER

← DANGER

NAVY

