

TP-63E Kingcobra

DORA
WINGS



1/48
SCALE

DW 48003

Yarshenko

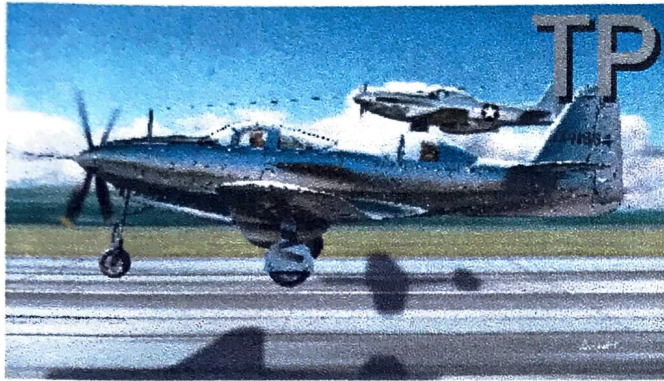

TP-63E Kingcobra

1/48 SCALE MODEL CONSTRUCTION KIT

Ready to assemble scale models kit.

Contains part for one model.

Model length: 208 mm

Wingspan: 244 mm

Plastic parts: 136

Photoetched parts: 34

An entirely different two-seater was produced by the Bell company for internal use. Two P-63E-1s were modified by Bell with a separate observer seat in the rear fuselage, located behind the engine and mounted under a separate canopy. A probe was mounted which extended through the spinner, and to make space for the observer the radio equipment had to be moved forward into the armament bay. The aircraft carried the civilian registrations NX41963 and Nx41964.

PARTS OF THE MODEL

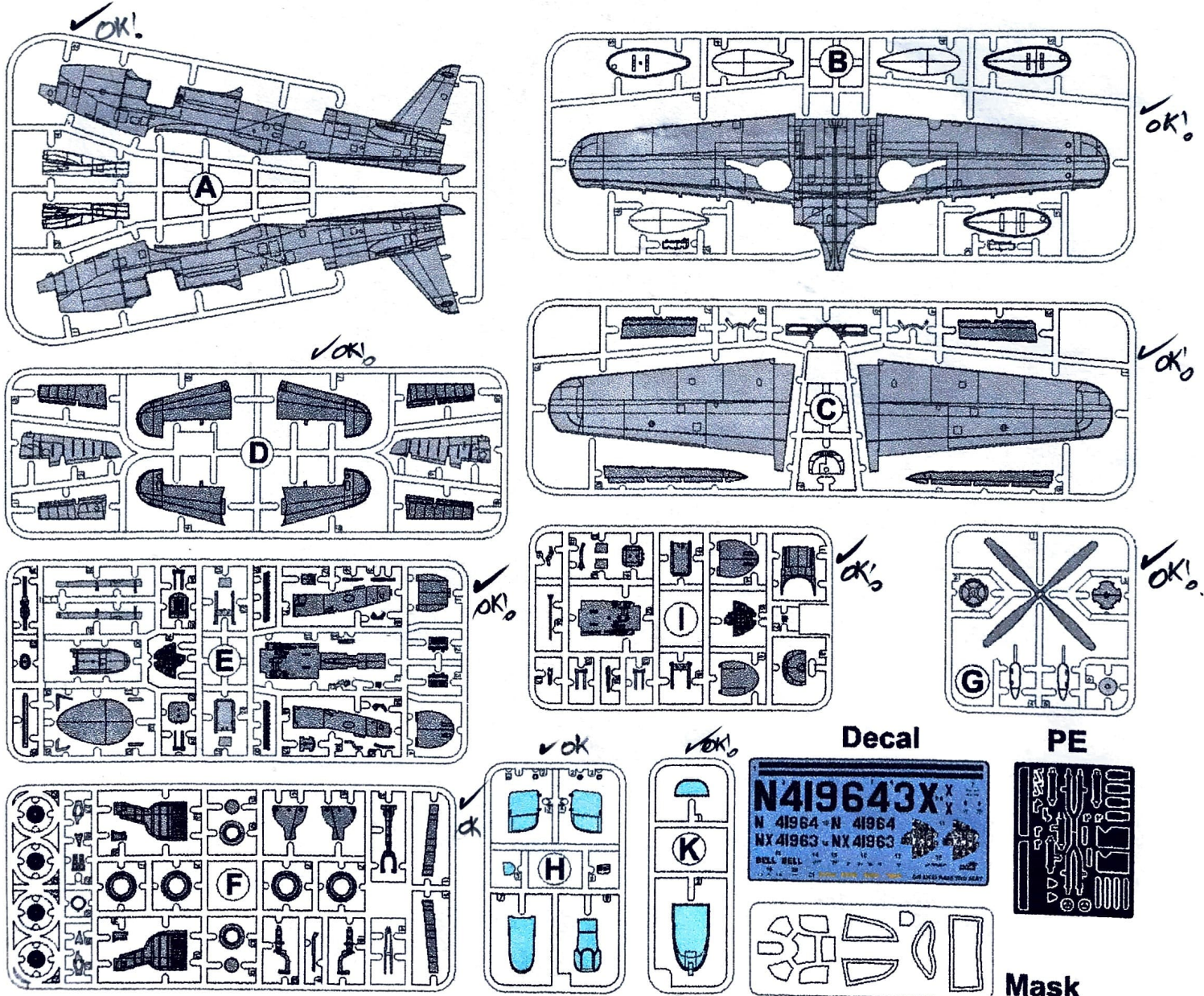

ASSEMBLY INSTRUCTION

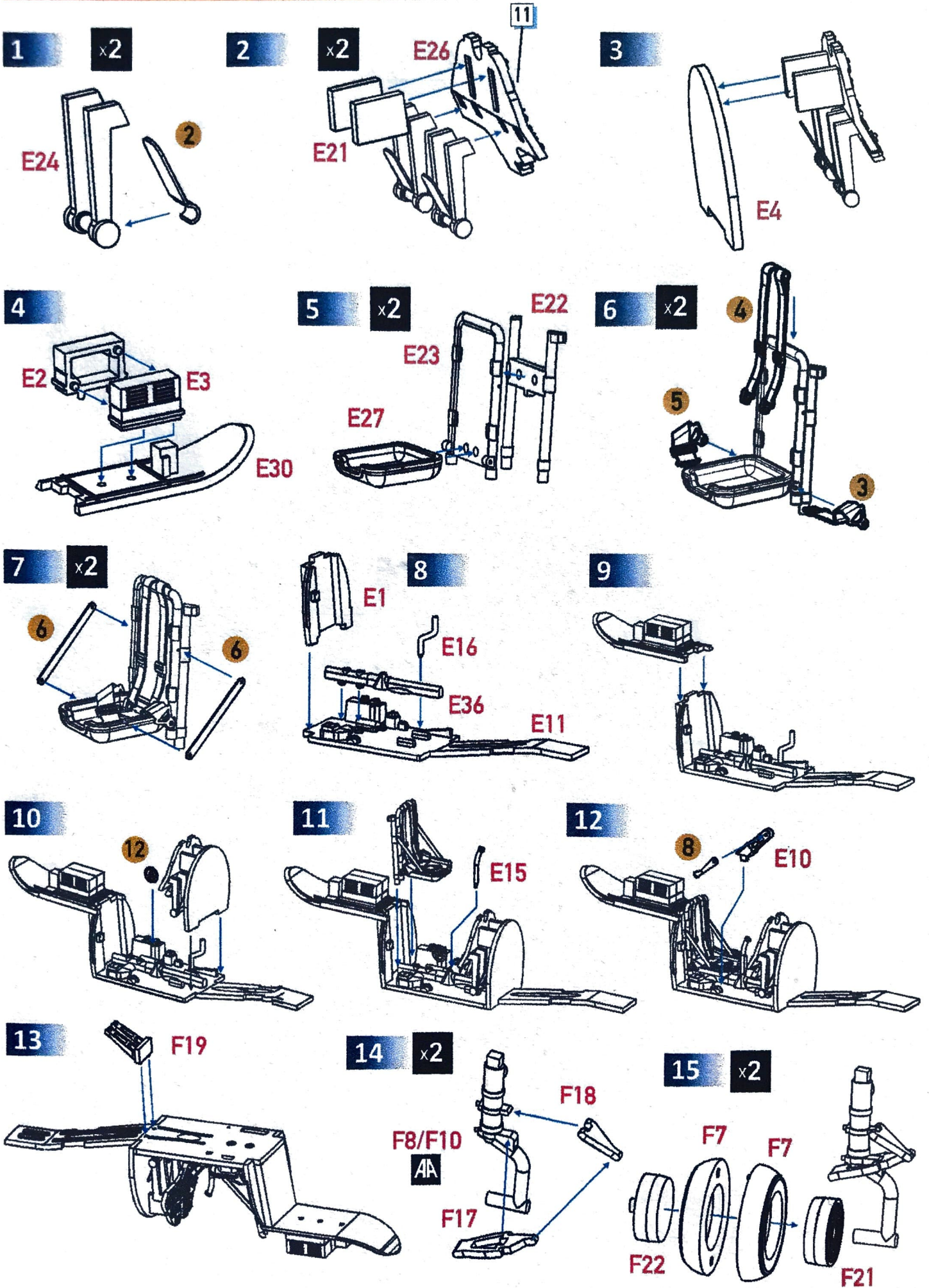

16

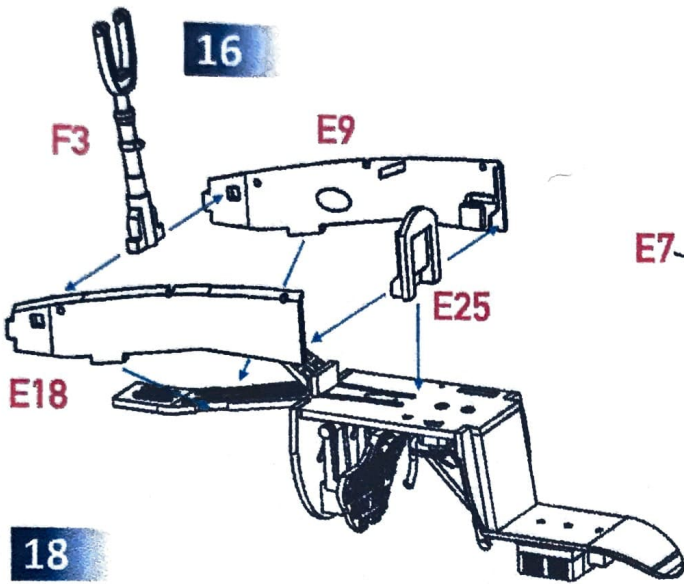

17

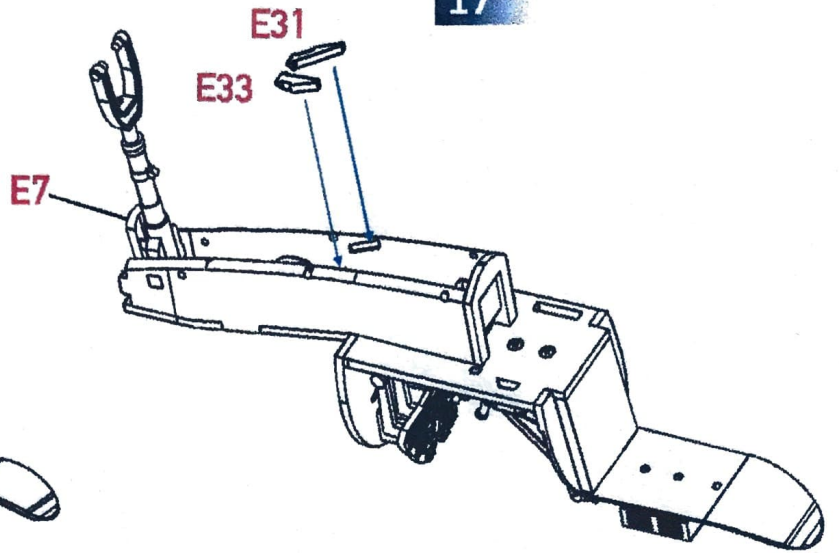

18

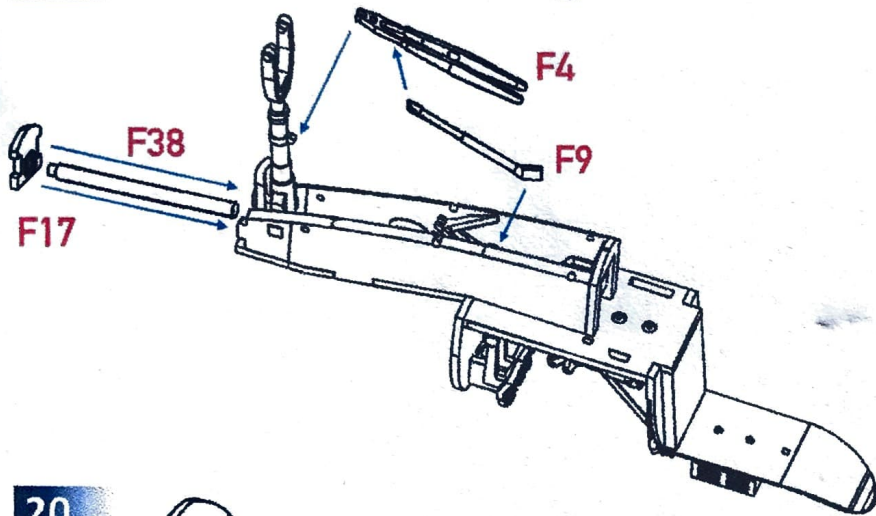

19 x2 AA

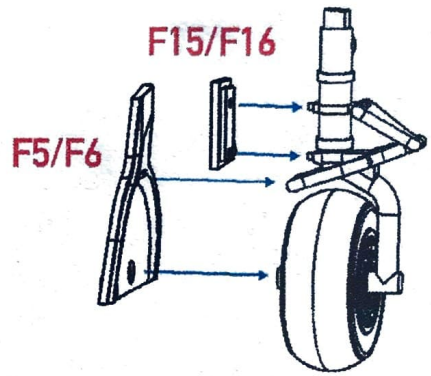

20

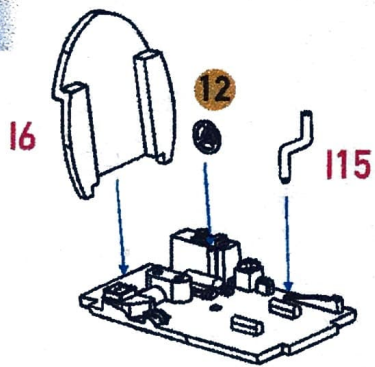

21

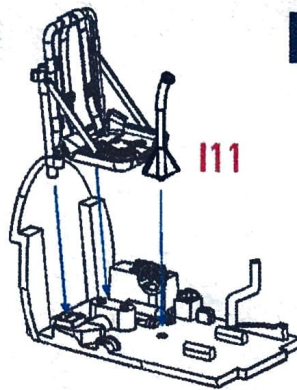

22

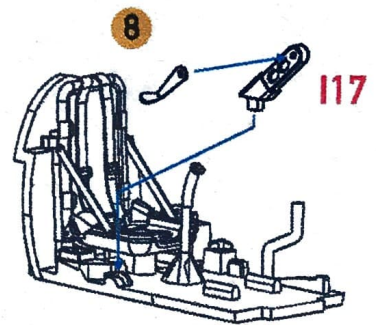

23

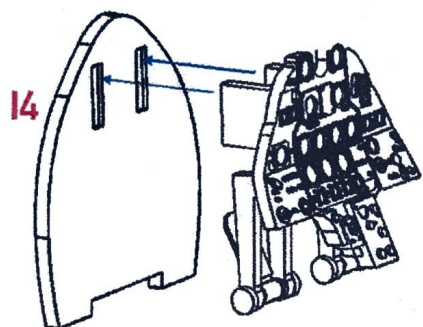

24

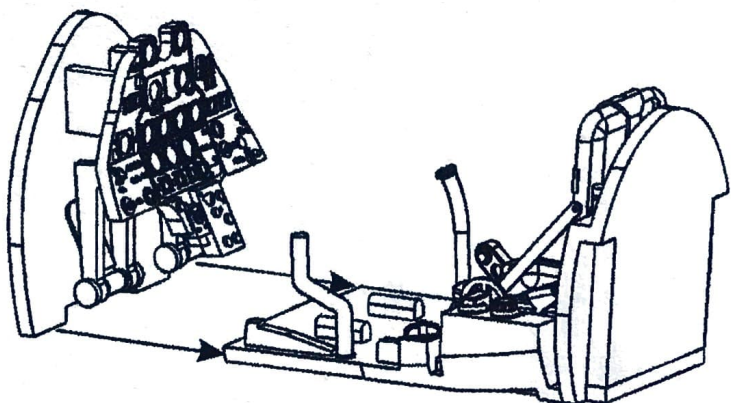

25

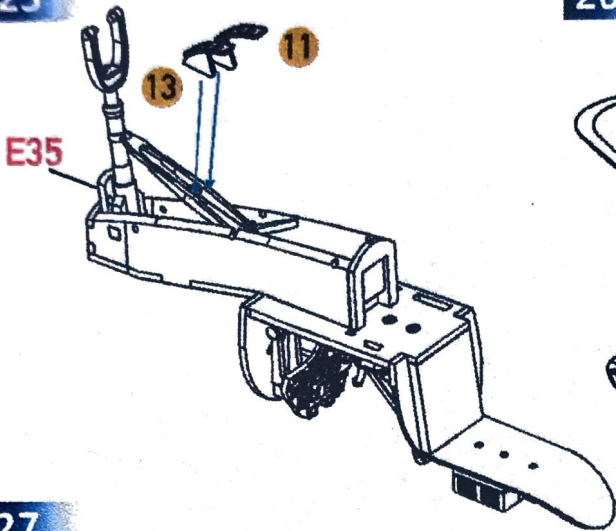

26

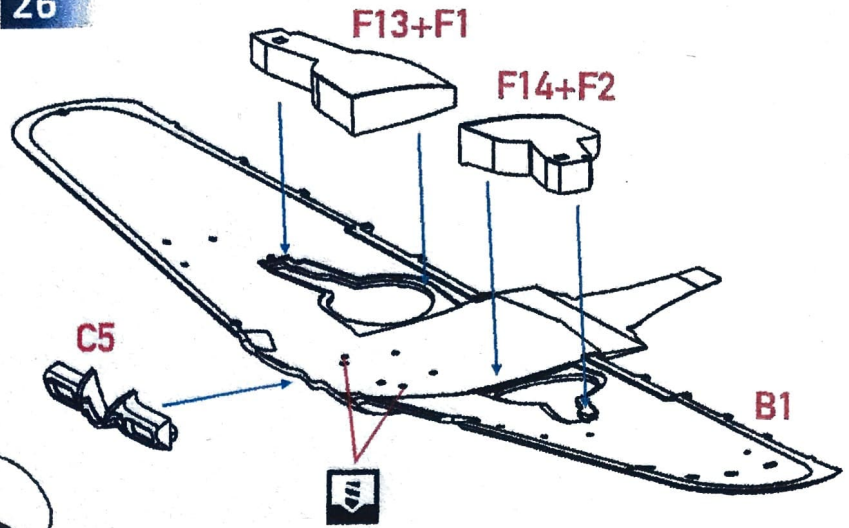

27

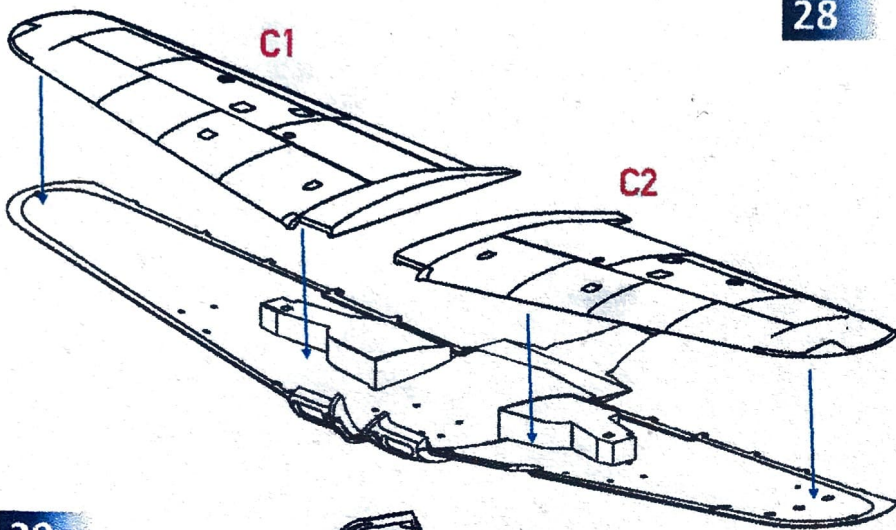

28

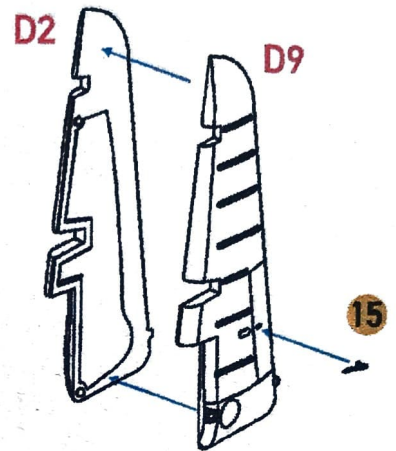

29

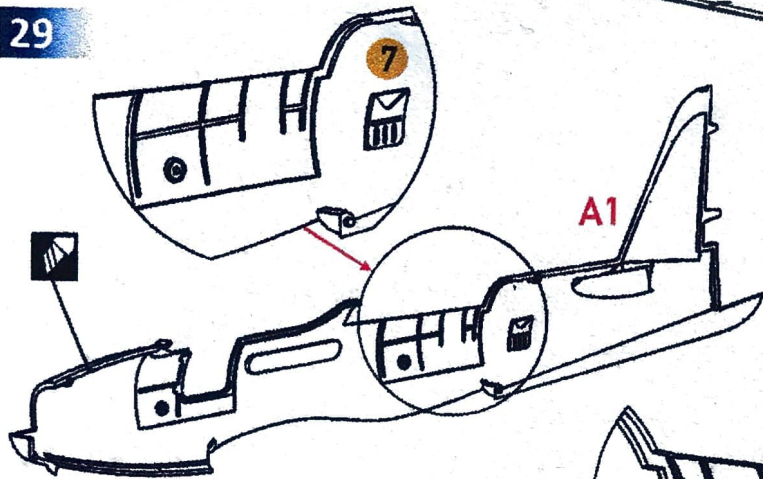

30

x2

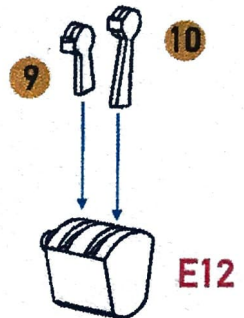

31

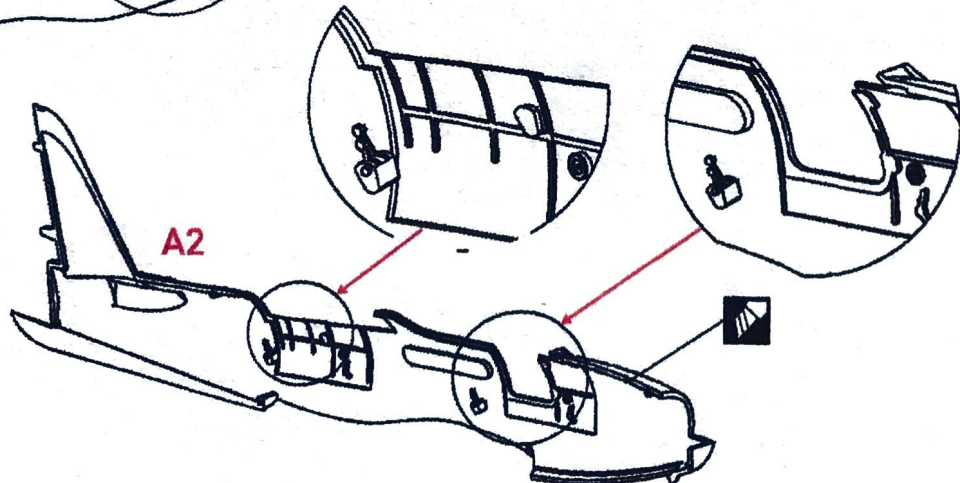

32

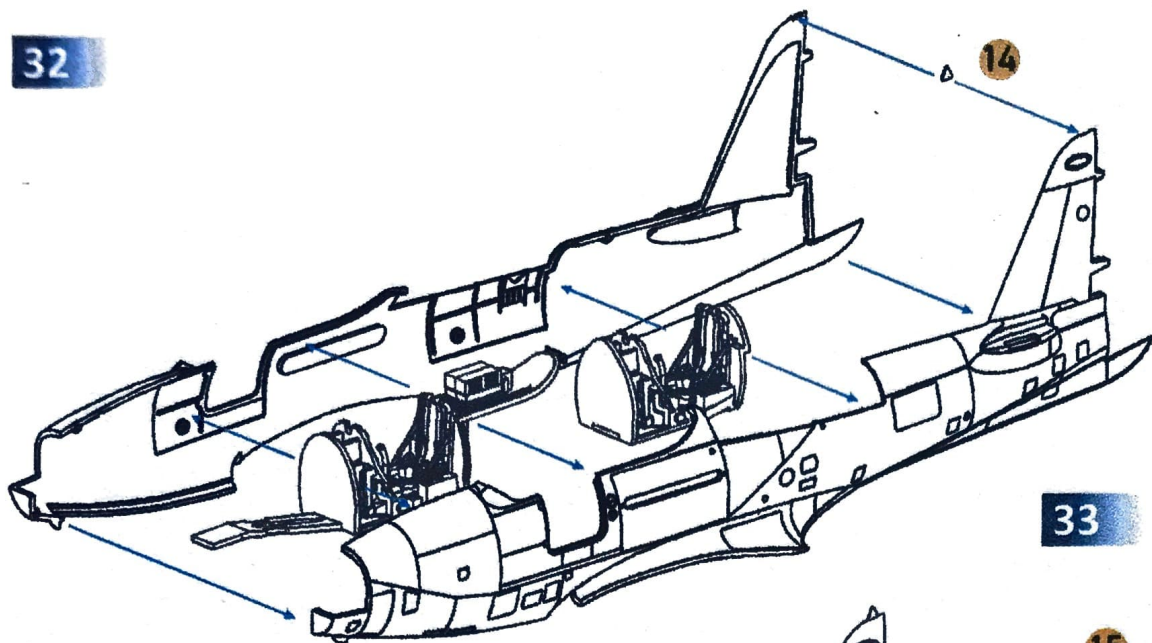

33 x2 AA

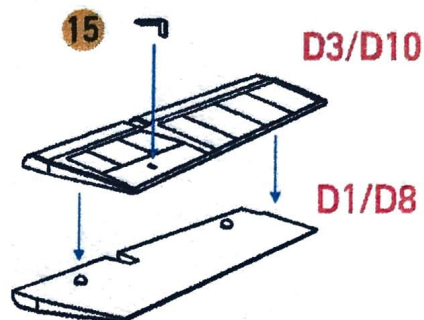

34

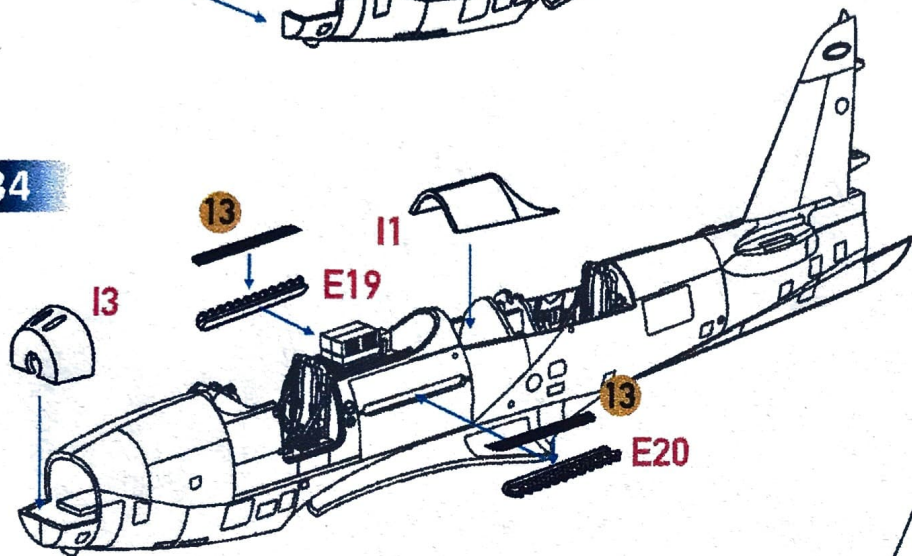

35

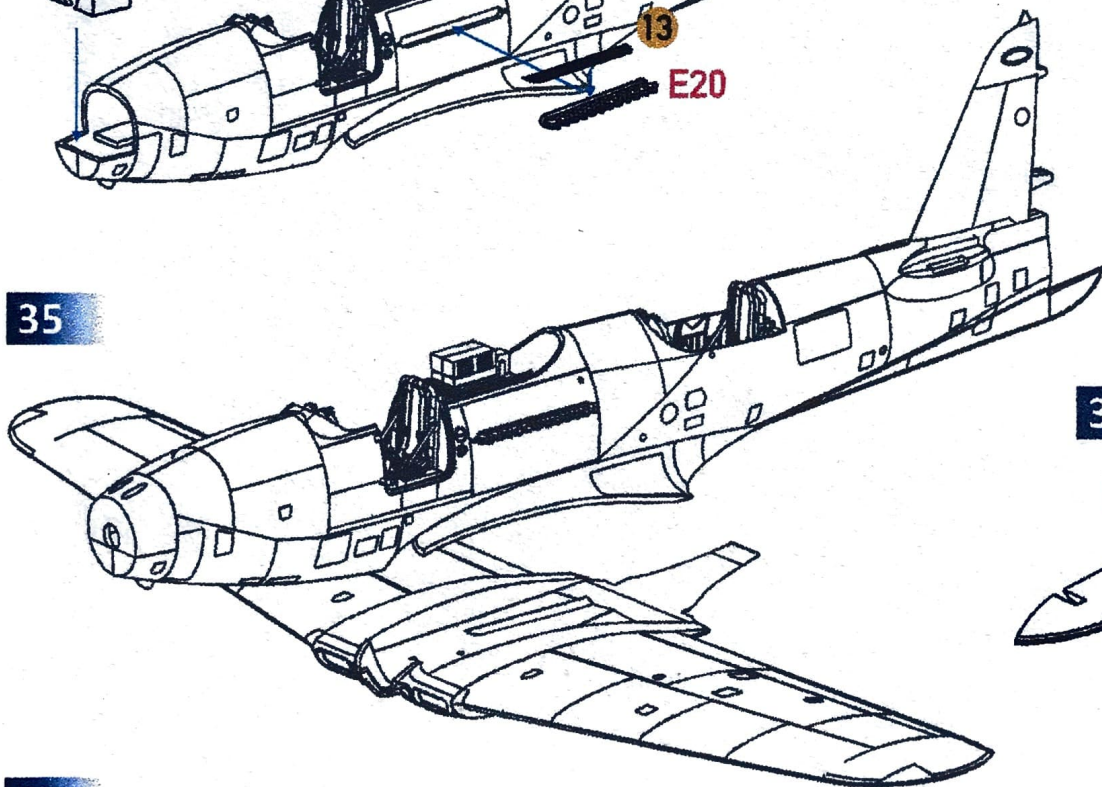

36

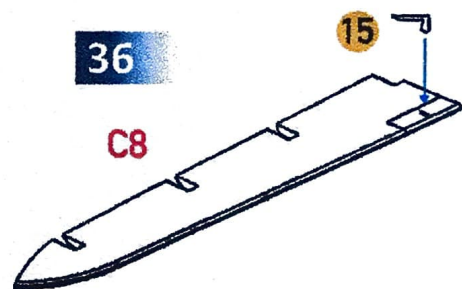

37

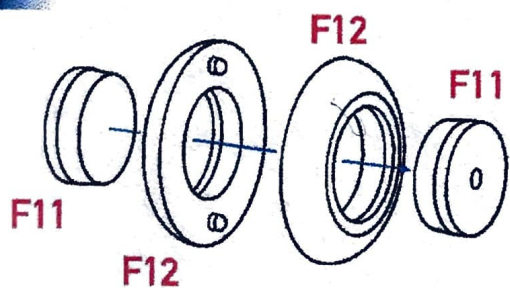

38

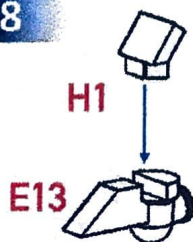

39

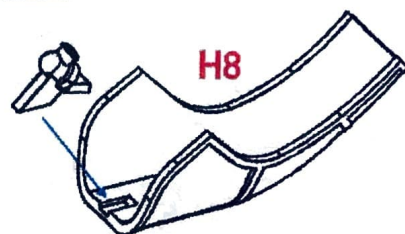

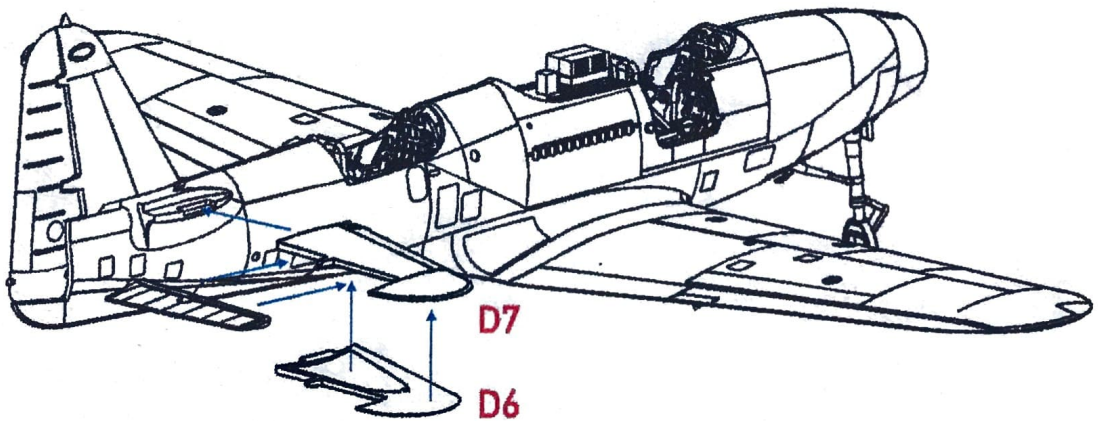
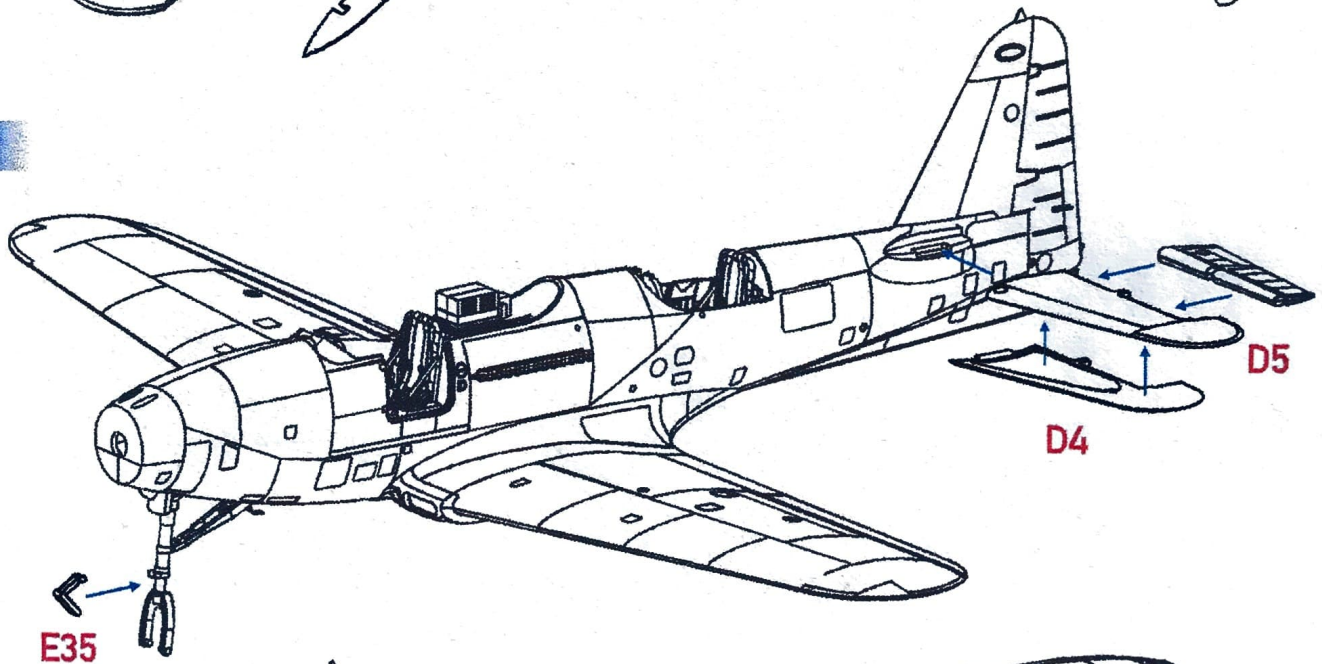
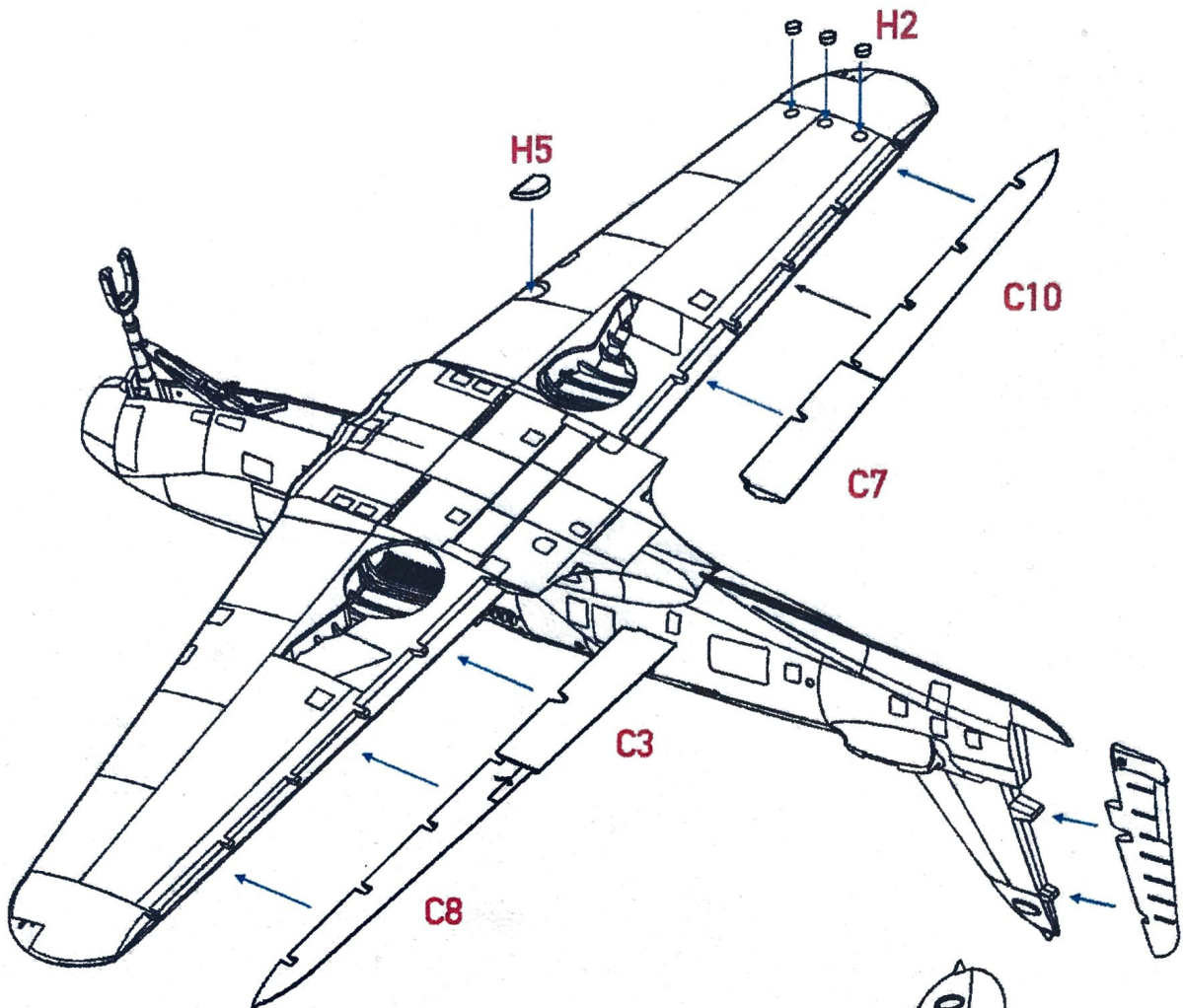

43

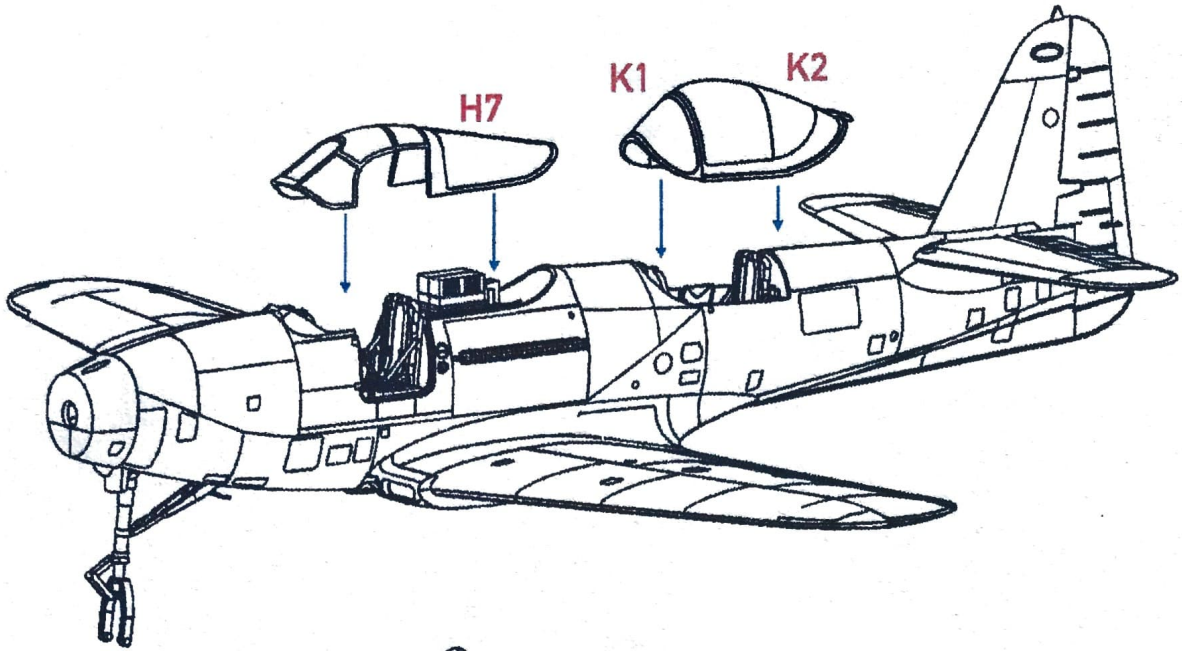

44

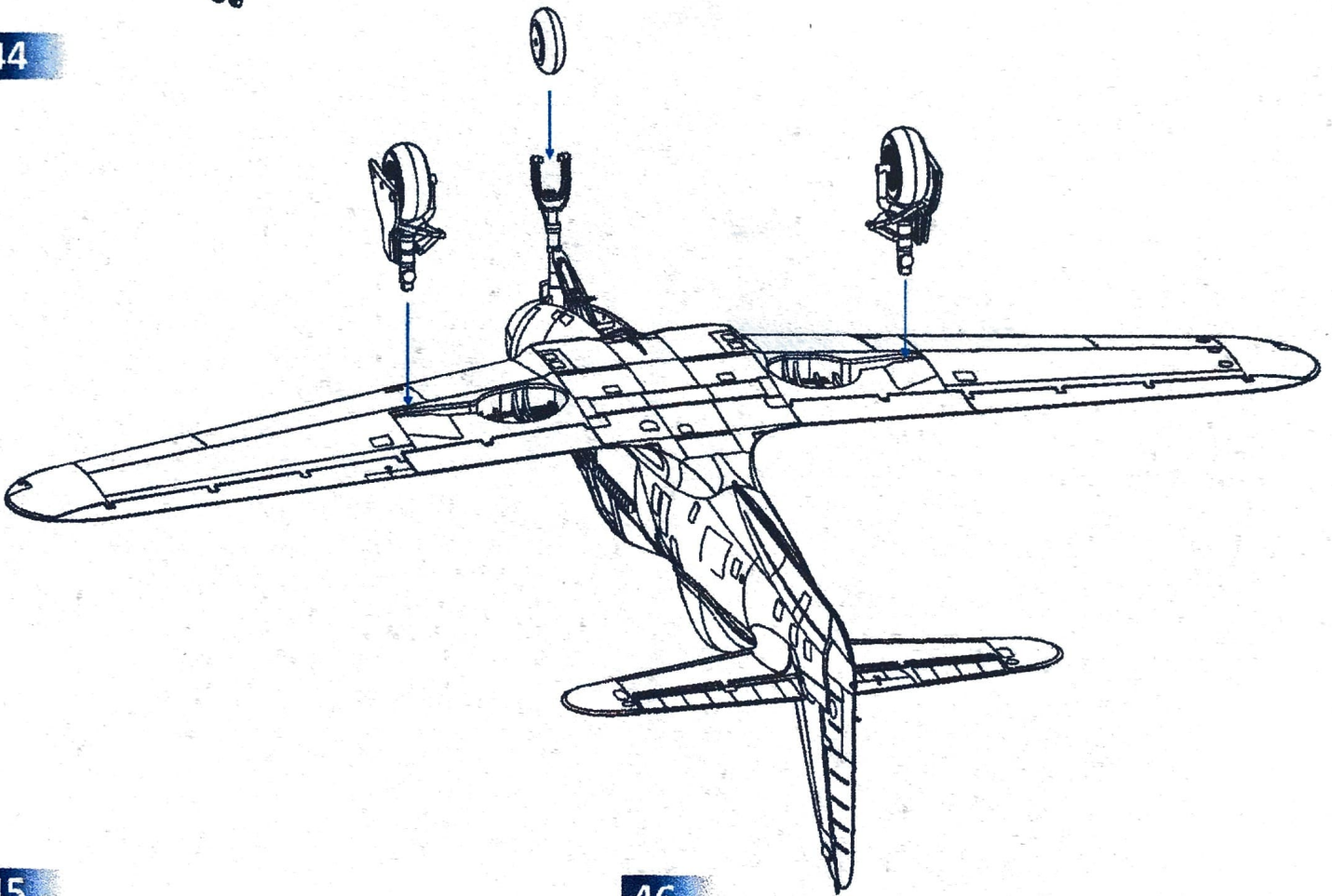

45

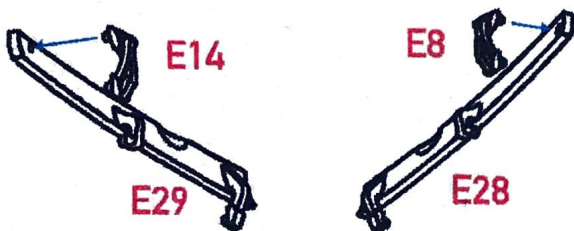

46

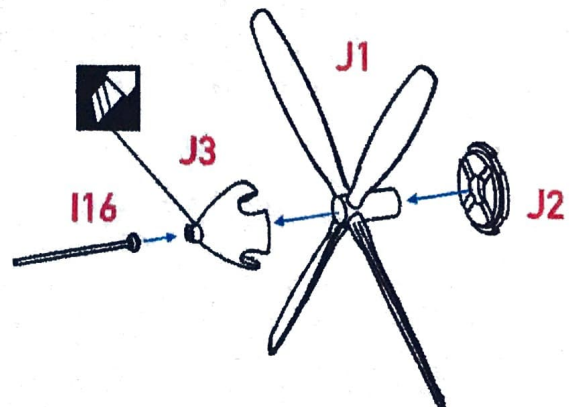

47

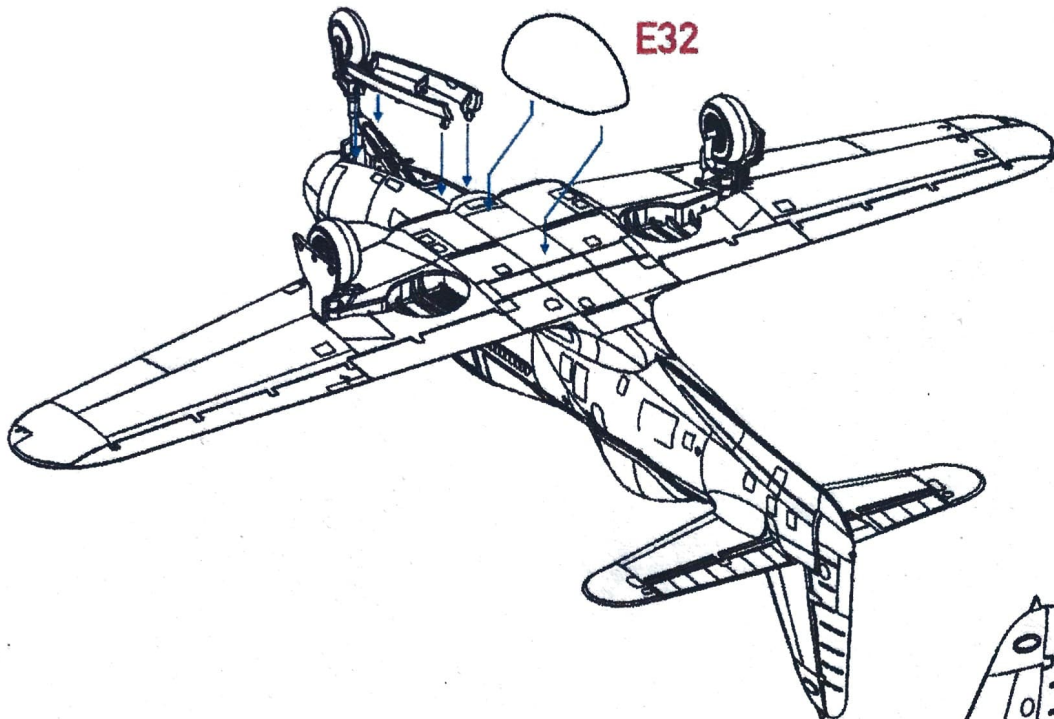

48

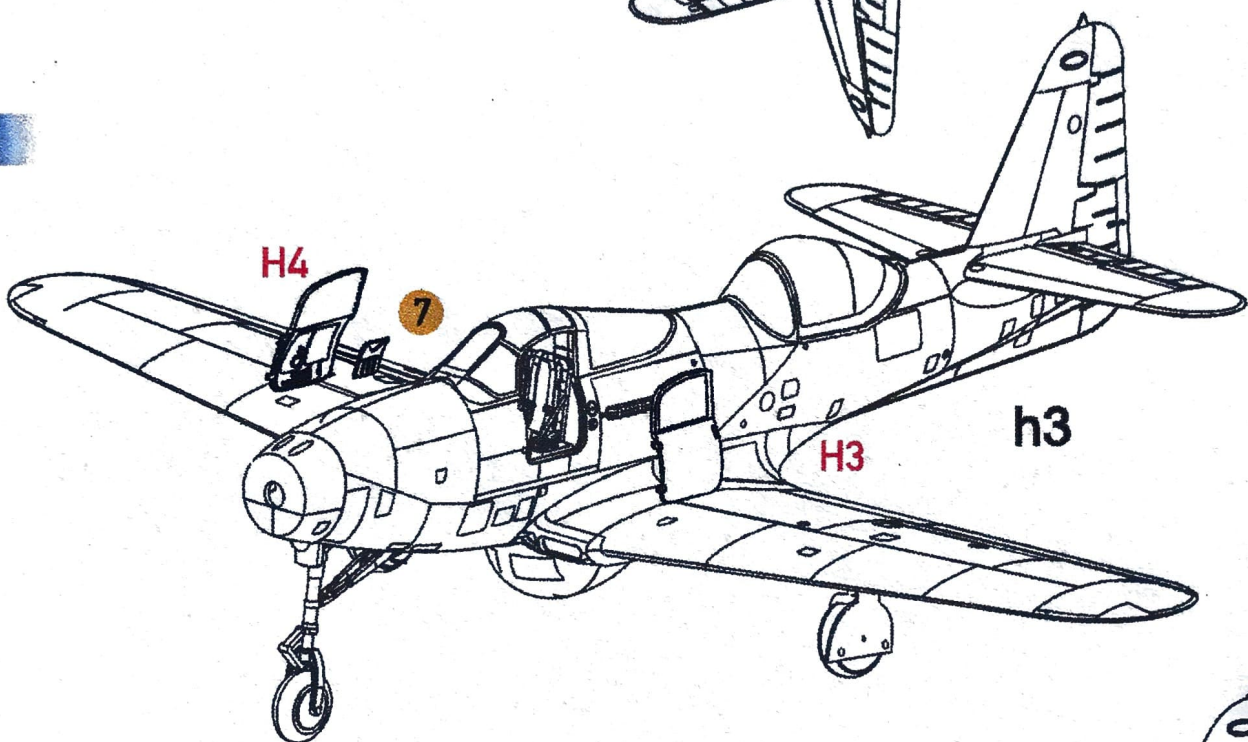

49

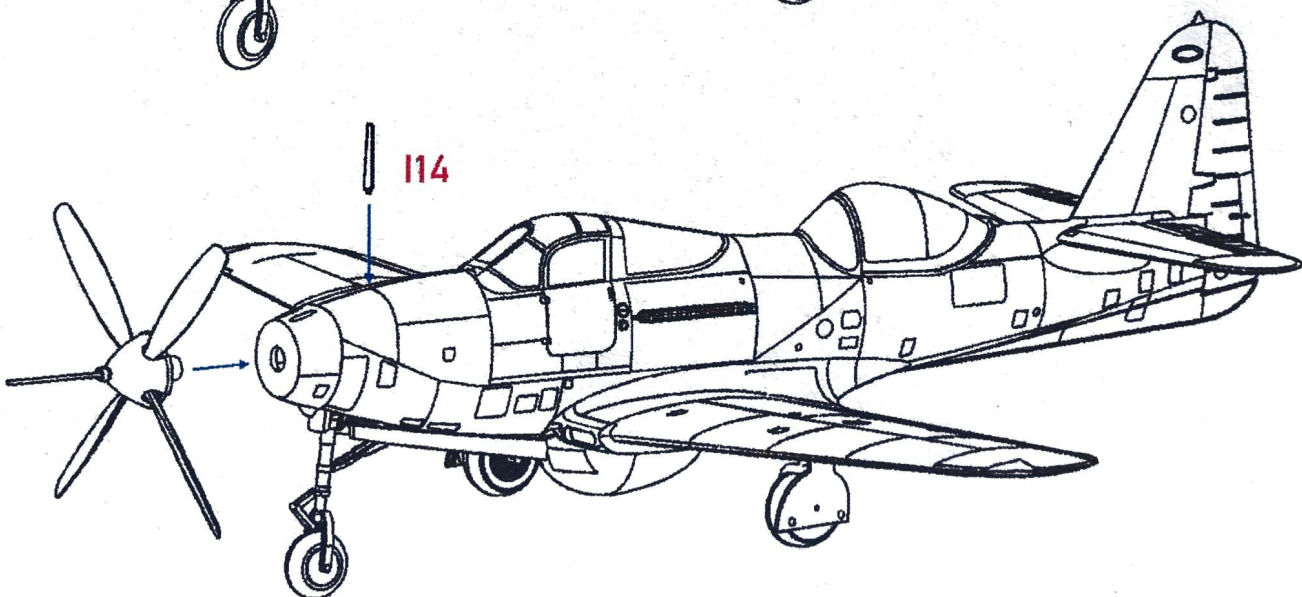

USED SYMBOLS



CEMENT



DON'T CEMENT



REMOVE



SYMMETRICAL



MULTIPLE



BEND



OPEN WHOLE



VARIANTS



TO PAINT

COLOR SCHEME

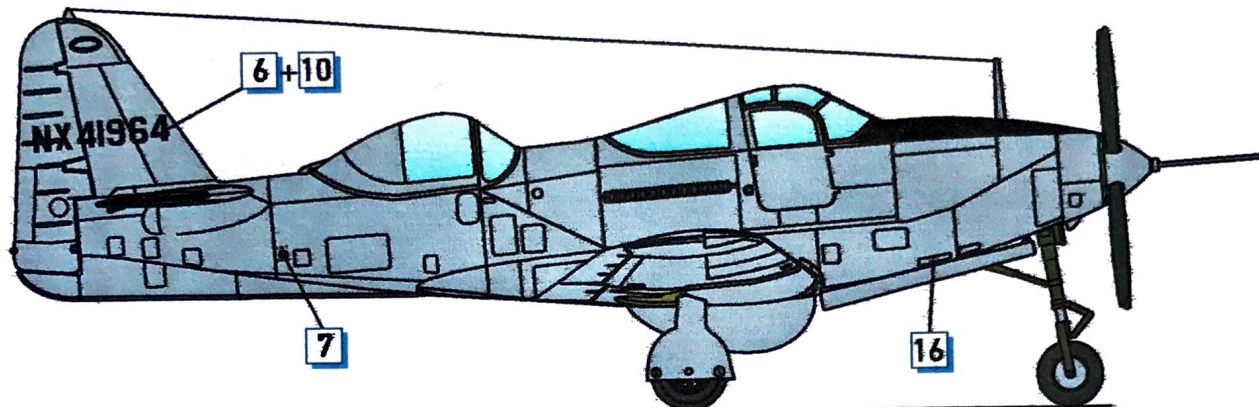
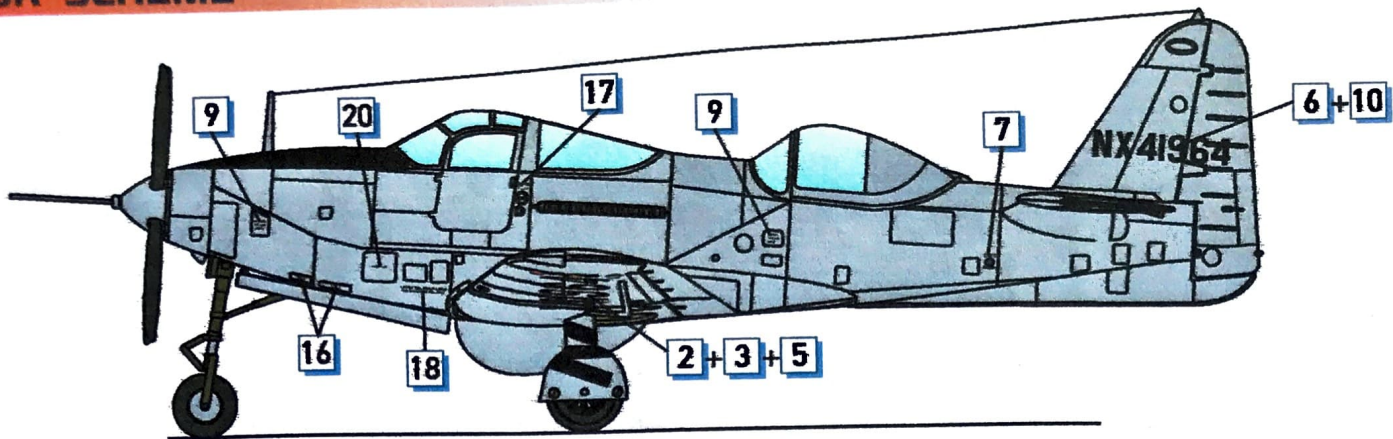

1) Civil two-seater mod NX 41964, General Electric Air Research Demonstration
Schenectady, New York, June 22, 1946

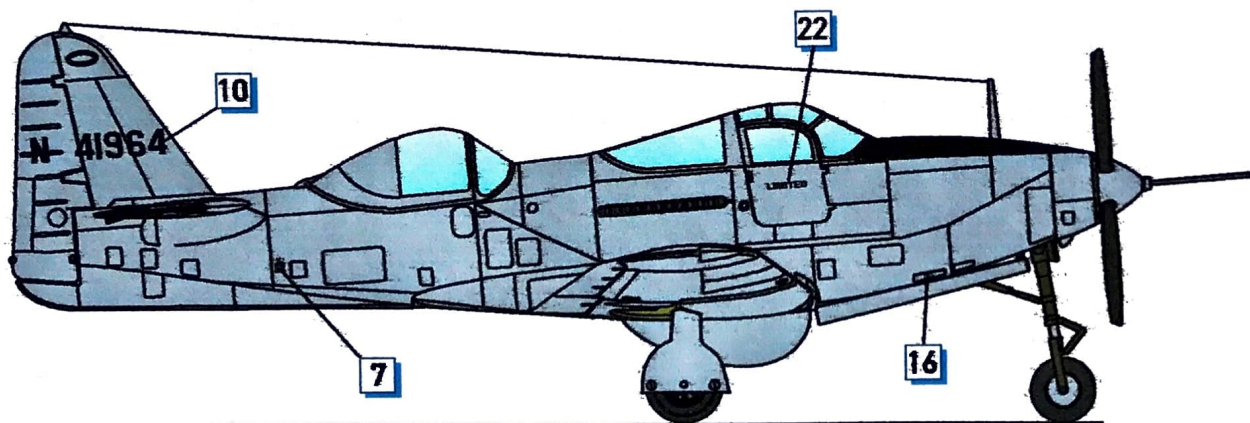
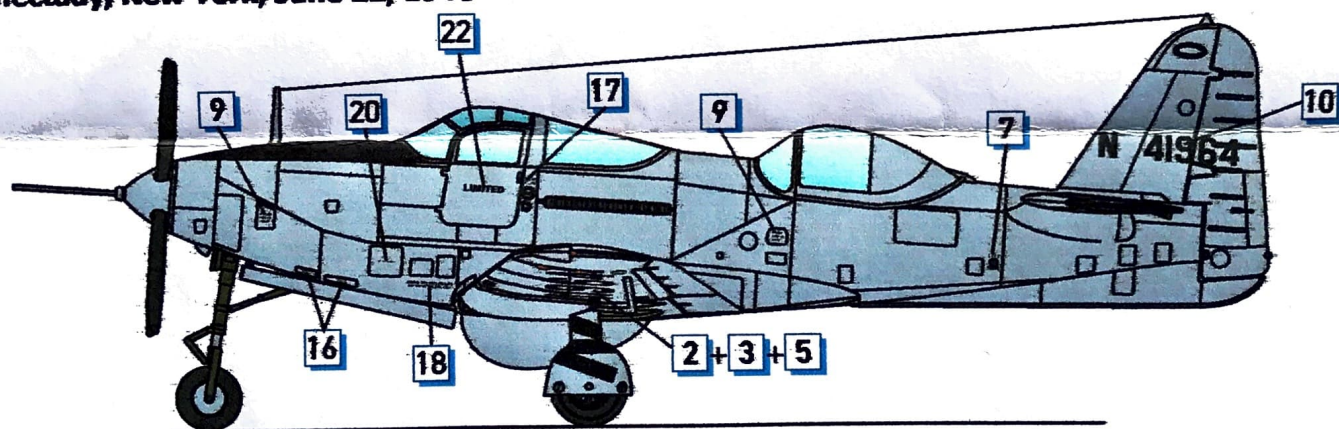

2) Civil two-seater mod NX41964, exported FA Hondurena, October 1948



Aluminum
Humbrol 56



Red
Humbrol 60



Interior Green



Matt Black
Humbrol 56



Orange
Humbrol 82



Green
Humbrol 120



Rust
Humbrol 113



Yellow
Humbrol 24



Olive Drab
Humbrol 66

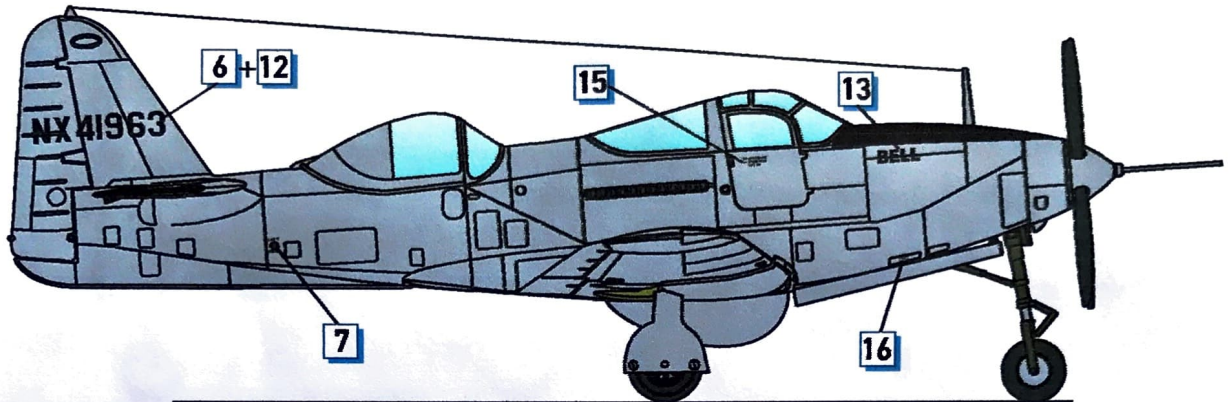
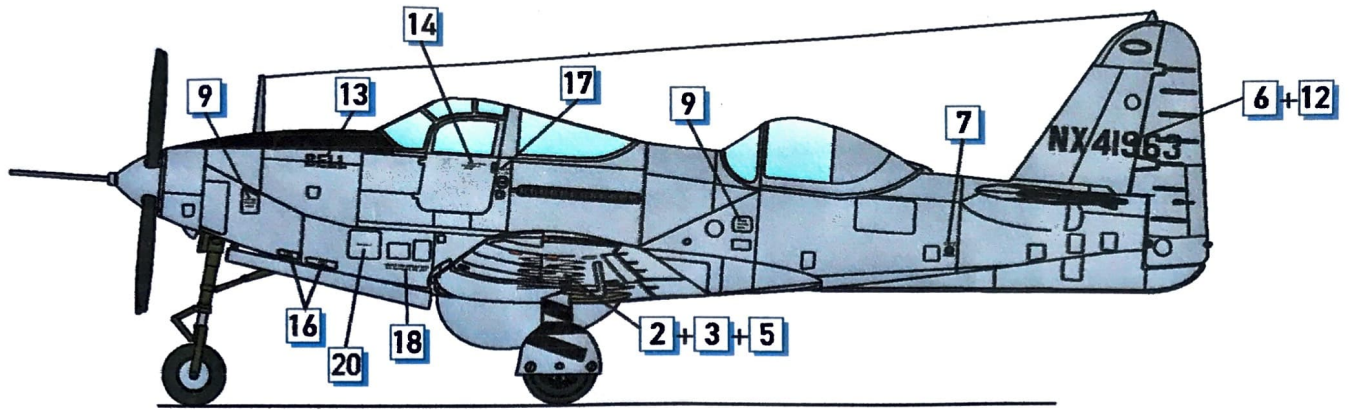

3) Civil two-seater mod NX 41963, May 1947

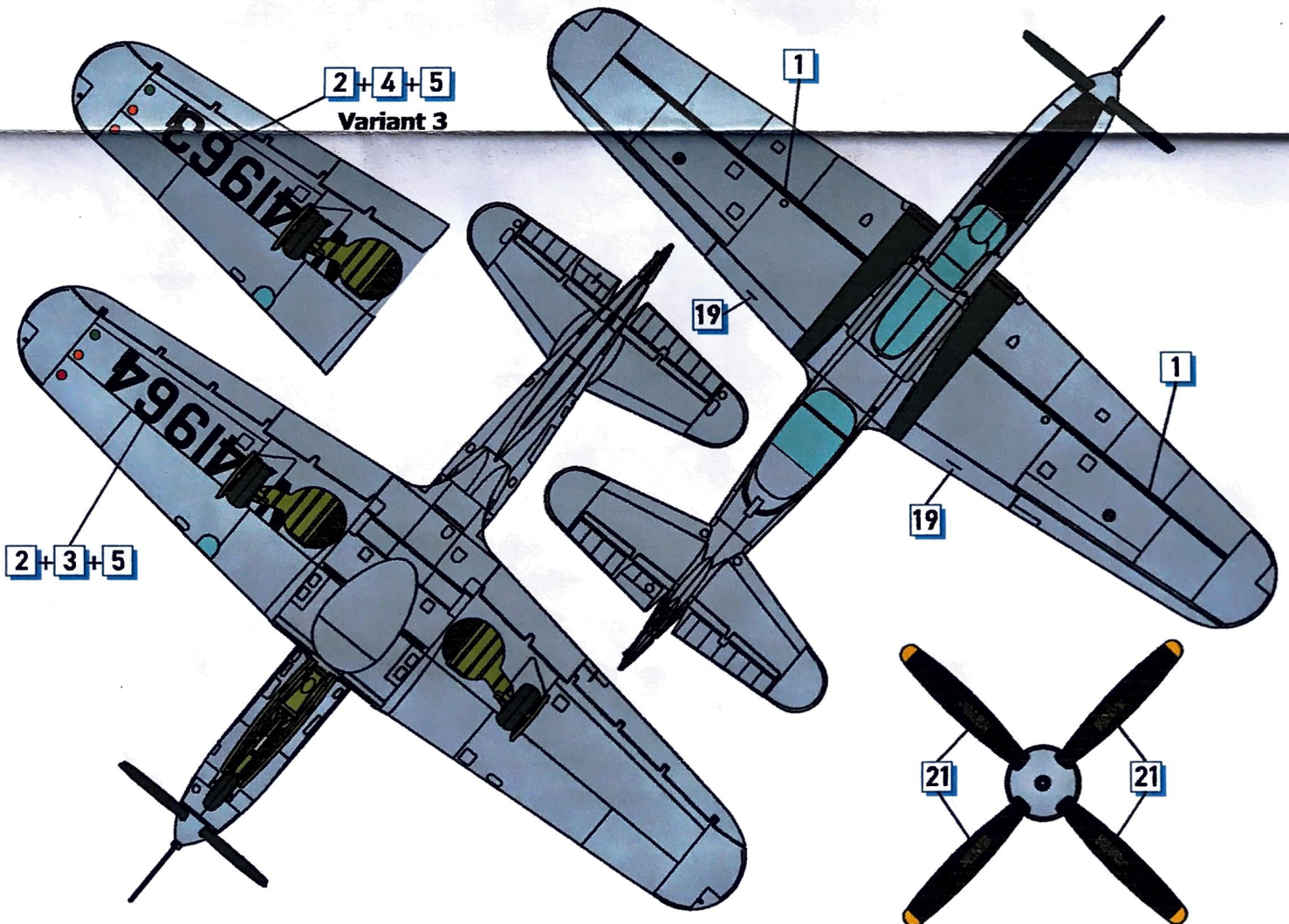

1

N41964343X⁵⁶X⁷

LIFT MOOR MOOR
LIFT MOOR
DRYER FLECK VALVE
LUBRICATION STARTER PLATE

N 41964¹⁰ N 41964

NX 41963¹² NX 41963

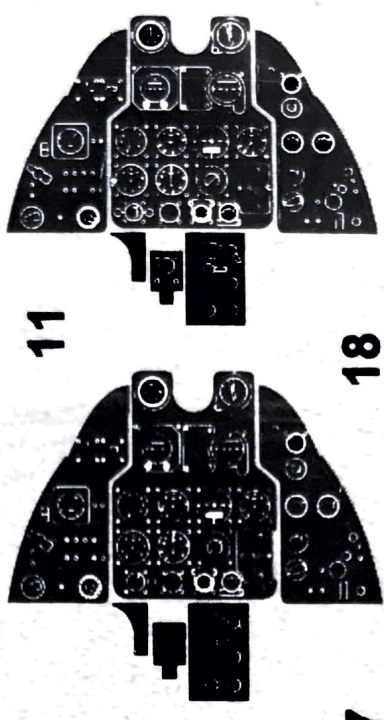

17
COOLANT FILLER

16
EJECT CHUTE

15
EJECT CHUTE

14
EJECT CHUTE

13
EJECT CHUTE

TO OPEN DOOR -
LIFT UP

TO OPEN DOOR -
LIFT UP

TO OPEN DOOR -
LIFT UP

TO OPEN DOOR -
LIFT UP

TO OPEN DOOR -
LIFT UP

TO OPEN DOOR -
LIFT UP

TO OPEN DOOR -
LIFT UP

TO OPEN DOOR -
LIFT UP



SERVICE THIS AIRPLANE WITH
WING DOOR OPENING FUEL ONLY

19 NO STEP NO STEP

20 NO STEP

21

DW 48003 P-63E TWO SEAT

LIMITED LIMITED

