

Revell

KIT 5714

85571400200

B-1B LANCER

The B-1B Lancer is the largest free world aircraft yet built to use a variable-geometry, or movable wing, which is designed to provide maximum aircraft performance. With the retirement of the EF-111 Raven in 1998 and the F-14 Tomcat in 2006, the B-1B is the last variable wing aircraft remaining in U.S. military inventory.

Your Revell B-1B features detailed cockpit and nose radar plus movable swing wings and tailplanes, optional open or closed bomb bay doors with 16 AGM-69A SRAM missiles on rotary launchers, detailed main landing gear, removable emergency exit hatch and authentic decal markings for two versions.



* REPEAT SEVERAL TIMES
* A REPETER PLUSIEURS FOIS



* OPTIONAL PARTS
* PIECES EN OPTION



* DECAL
* DECAL COMANIE



* ALTERNATIVE ASSEMBLY
* ENSEMBLAGE ALTERNATIVE



* CEMENT TOGETHER
* A COLLER



* REMOVE AND THROW AWAY
* A RETIRER ET JETER



* DO NOT CEMENT
* NE PAS COLLER

READ THIS BEFORE YOU BEGIN

- * Study the assembly drawings.
- * Each plastic part is identified by a number.
- * In the assembly drawings, some parts will be marked by a star (★) to indicate chrome plated plastic.
- * For better paint and decal adhesion, wash the plastic parts in a mild detergent solution. Rinse and let air dry.
- * Check the fit of each piece before cementing in place.
- * Use only cement for polystyrene plastic.
- * Scrape plating and paint from areas to be cemented.
- * Allow paint to dry thoroughly before handling parts.
- * Any unused parts may be discarded.

DECAL APPLICATION INSTRUCTIONS

1. Cut desired decal from sheet.
2. Dip decal in water for a few seconds.
3. Place wet decal on paper towel.
4. Wait until decal is movable on paper backing.
5. Place decal in position on model, face up and slide backing away.
6. Press out air bubbles with a soft damp cloth.
7. Milkiness that may appear is for better decal adhesion and will dry clear. Wipe away any excess adhesive.
8. Do not touch decal until fully dry.
9. Allow the decals 48 hours to dry before applying clear coat.

NOTE: Decals are compatible with setting solutions or solvents.

LIRE CE QUI SUIT AVANT DE COMMENCER

- * Etudier les schémas de montage.
- * Chaque pièce en plastique est identifiée par un numéro.
- * Sur les schémas de montage, certaines pièces sont marquées d'une étoile (★) pour indiquer qu'elles sont en plastique chromé.
- * Pour une meilleure prise de la peinture et des autocollants, laver les pièces en plastique avec une solution détergente peu concentrée. Les rincer et les laisser sécher à l'air.
- * Vérifier que chaque pièce s'ajuste bien avant de la coller en place.
- * N'utiliser que de la colle pour polystyrène.
- * Gratter les parties à coller pour enlever le chrome et la peinture.
- * Laisser la peinture bien sécher avant de manipuler les pièces.
- * Toute pièce inutilisée peut être jetée.

DIRECTIVES D'APPLICATION DES AUTOCOLLANTS

1. Découper l'autocollant désiré de la feuille.
2. Tremper l'autocollant dans de l'eau pendant quelques secondes.
3. Placer l'autocollant mouillé sur une serviette en papier.
4. Attendez que l'autocollant puisse être déplacé sur son support en papier.
5. Mettre l'autocollant en position sur le modèle face sur le dessus et faire glisser le support pour l'enlever.
6. Appuyer avec un chiffon doux humide pour éliminer les bulles d'air.
7. La substance laiteuse qui peut apparaître est destinée à améliorer l'adhésion de l'autocollant et devient incolore au séchage. Essuyer pour enlever tout excédent d'adhésif.
8. Ne pas toucher l'autocollant tant qu'il n'est pas bien sec.
9. Laisser l'autocollant sécher pendant 48 heures avant d'appliquer une couche transparente.

REMARQUE: Les autocollants sont compatibles avec les solutions de fixation ou les solvants.

This paint guide is provided to complete this kit as shown on the box.

Ce guide de peintures est fourni pour reproduire le modèle réduit qui apparaît sur la boîte.

Gunship Gray	Gris hélicoptère
Dark Gray	Gris Foncé
Steel	Acier
Gloss White	Blanc brillant
Zinc Chromate	Chromate de zinc
Flat Light Gray	Gris clair mat
Red	Rouge
Flat Black	Noir mat
Gold	Or
Green	Vert
Silver	Argent

If you have any questions or comments, call our hotline at: **(800) 833-3570** or, please write to:

Revell Inc Consumer Service Department, 1850 Howard Street Unit A, Elk Grove Village, Illinois 60007

Be sure to include the plan number (85571400200), part number, description, your return address and phone number.

Visit our website: www.revell.com

NOTE: THE LETTERS BEFORE THE PART NUMBERS REFER TO THE TREE THAT THE PART IS LOCATED ON.



REFER BACK TO THIS STEP ONLY IF YOU CHOOSE TO BUILD YOUR B-1B WITH THE LANDING GEAR AND BAY DOORS CLOSED

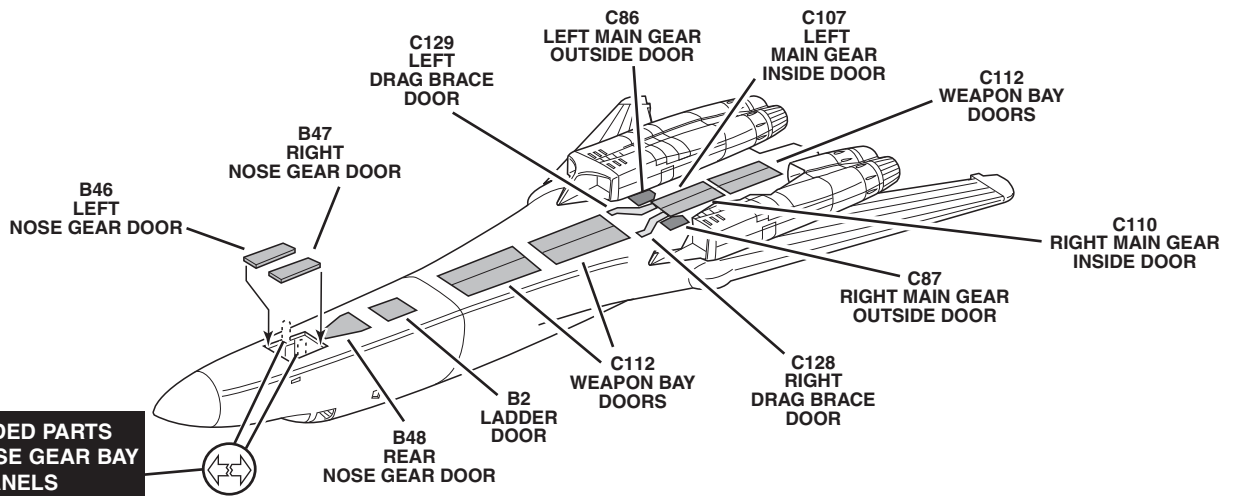
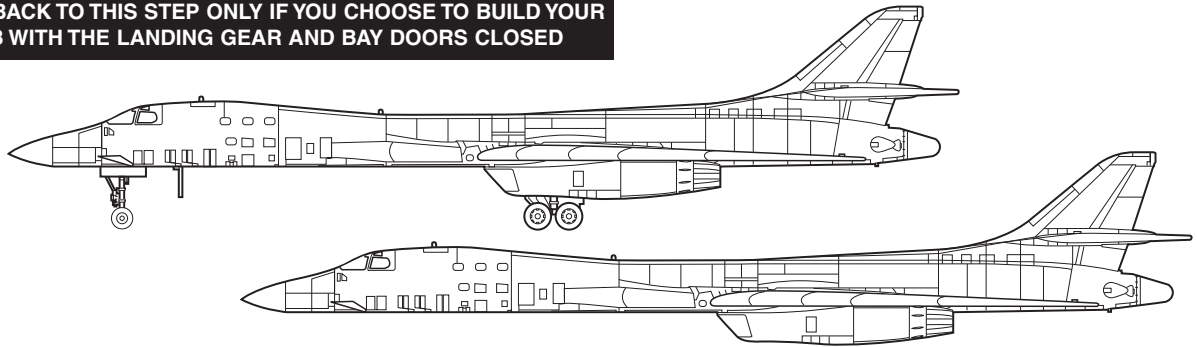

1

COCKPIT ASSEMBLY

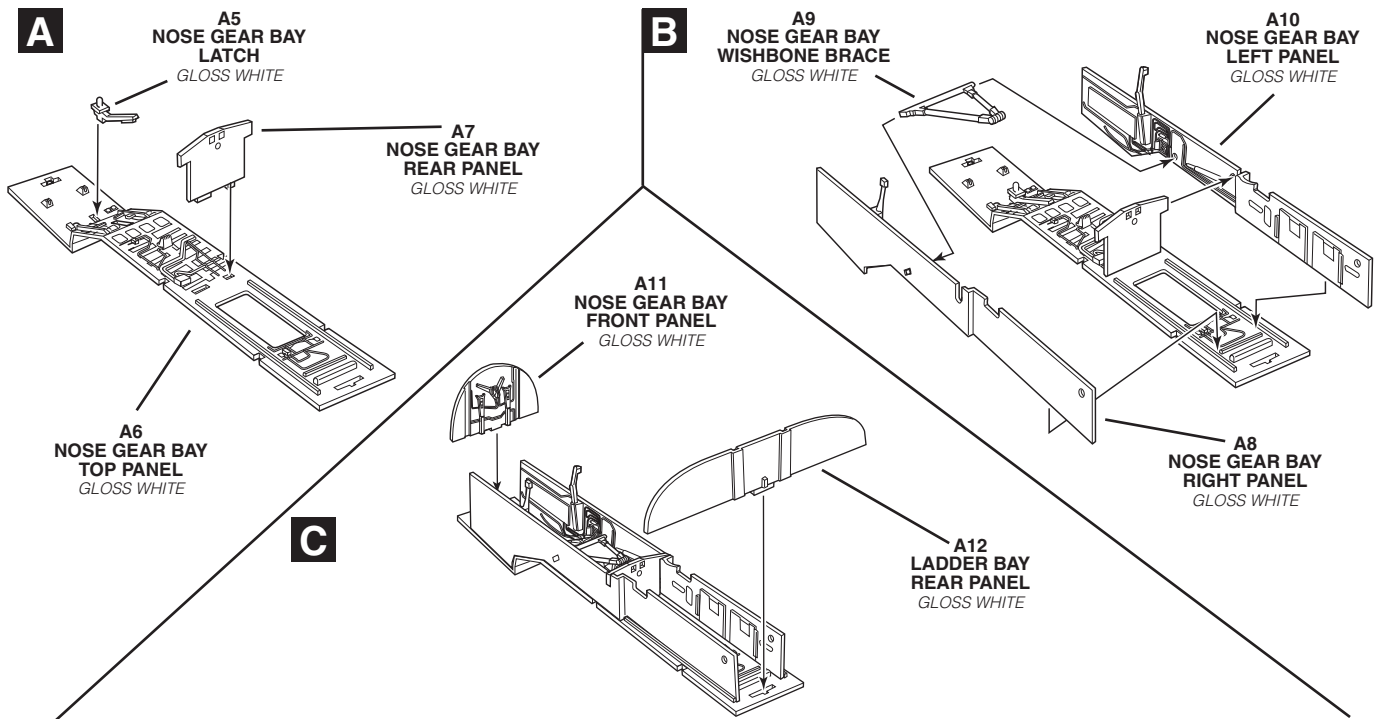

1

COCKPIT ASSEMBLY CONTINUED

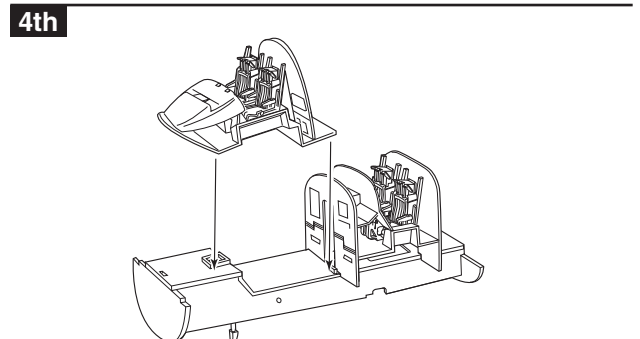
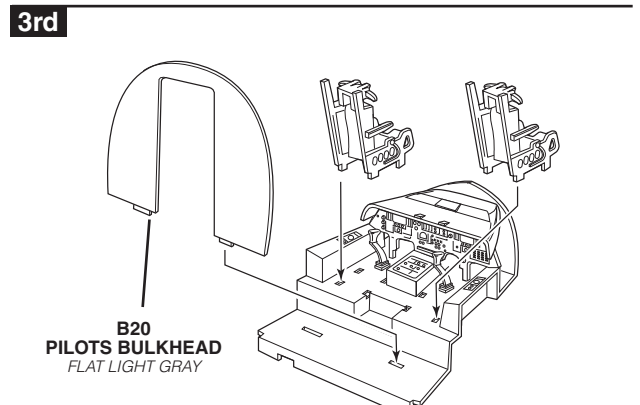
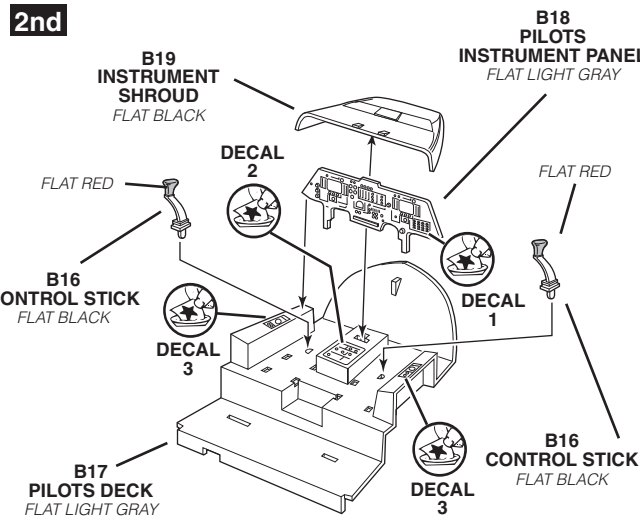
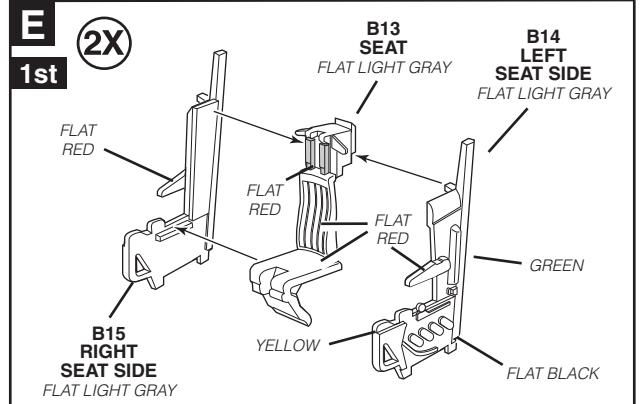
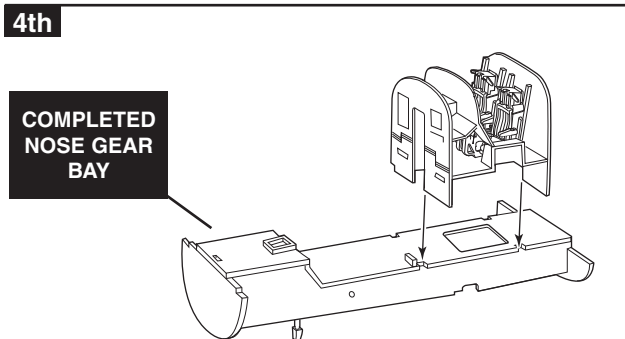
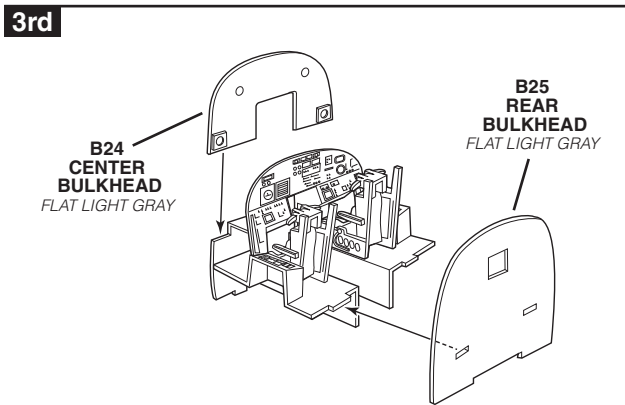
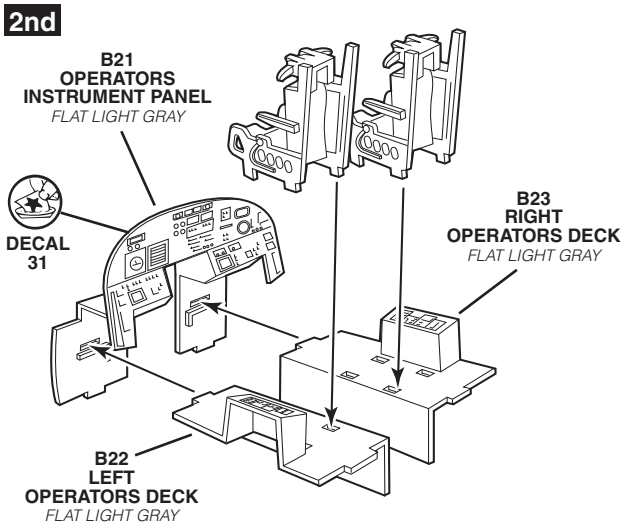
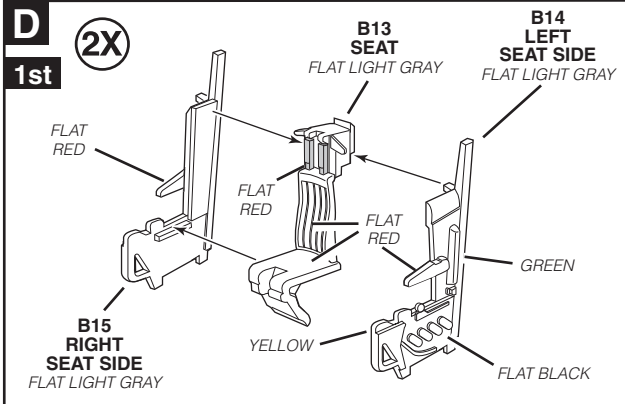

2

FRONT FUSELAGE ASSEMBLY

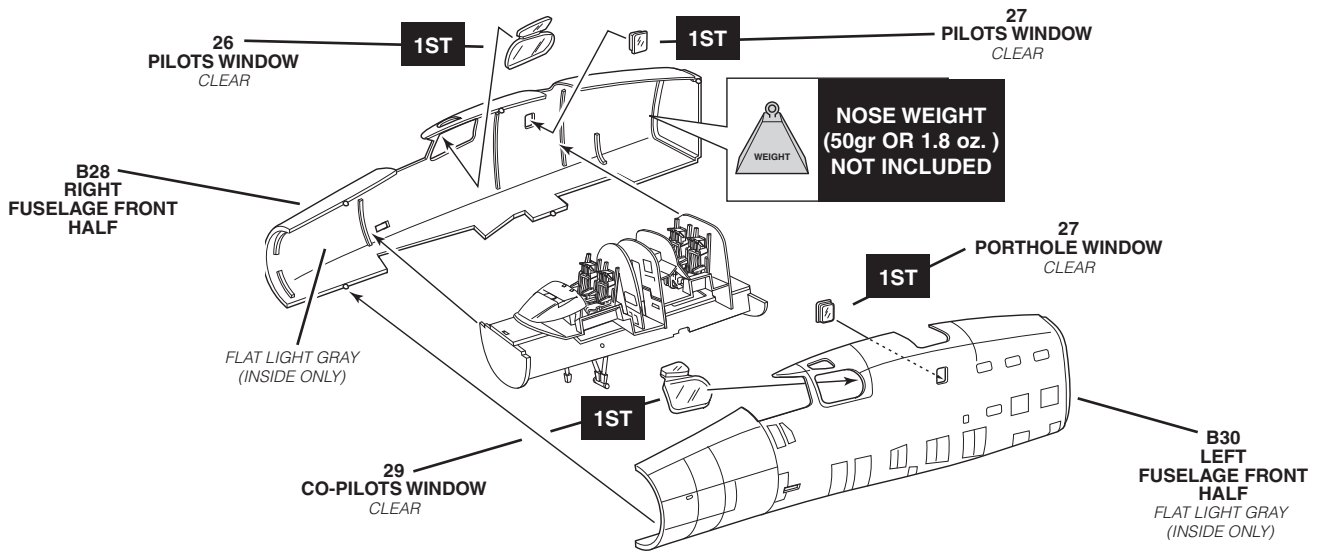

3

RADAR / LADDER ASSEMBLY

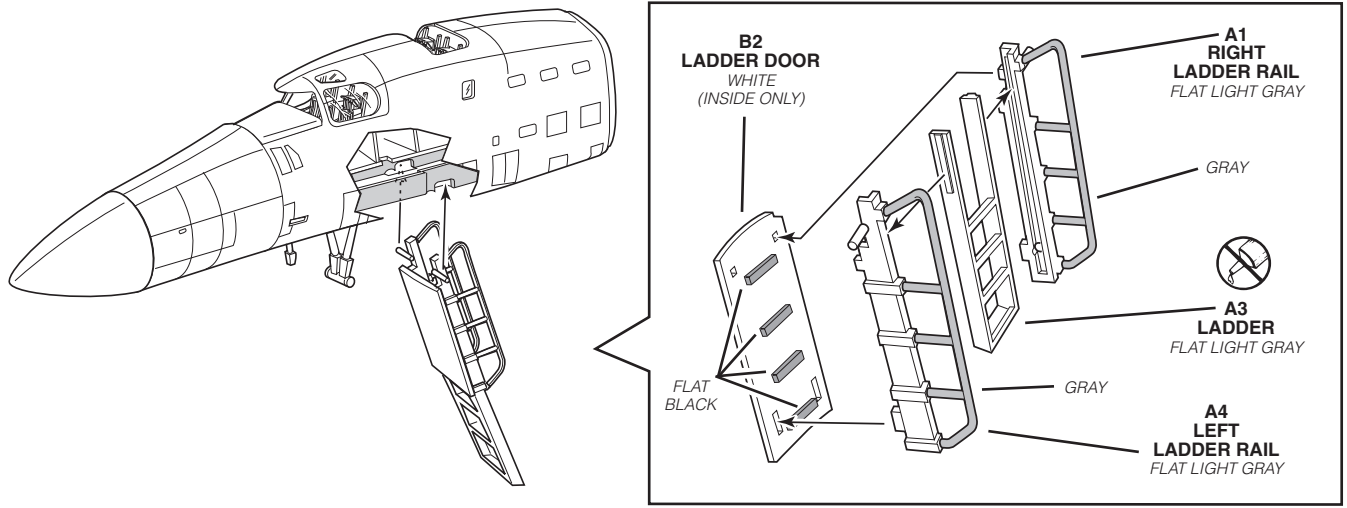
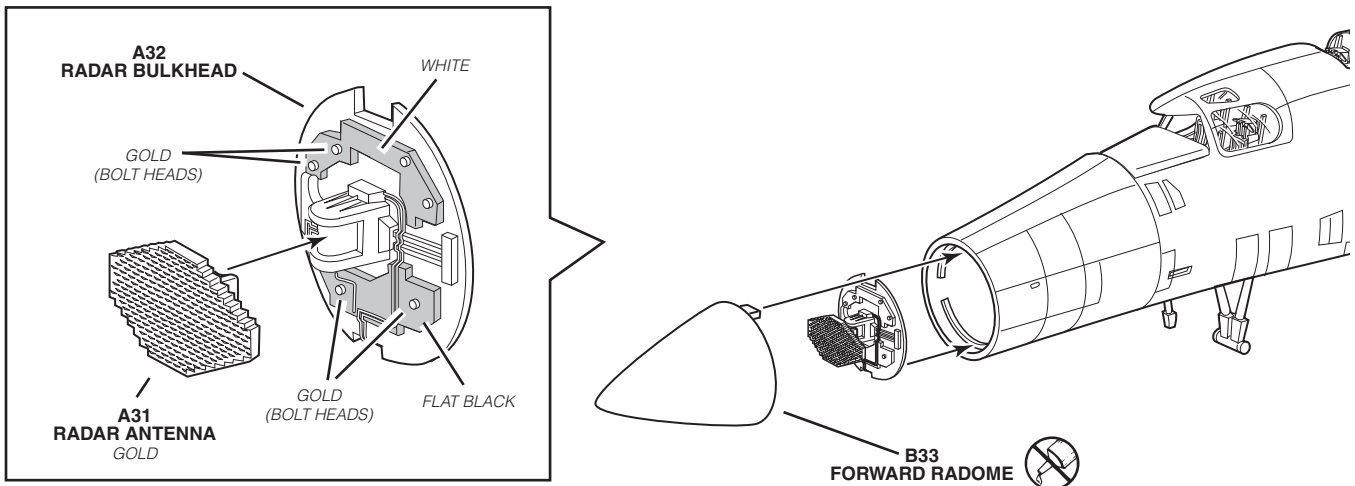

4

NOSE STRUT ASSEMBLY

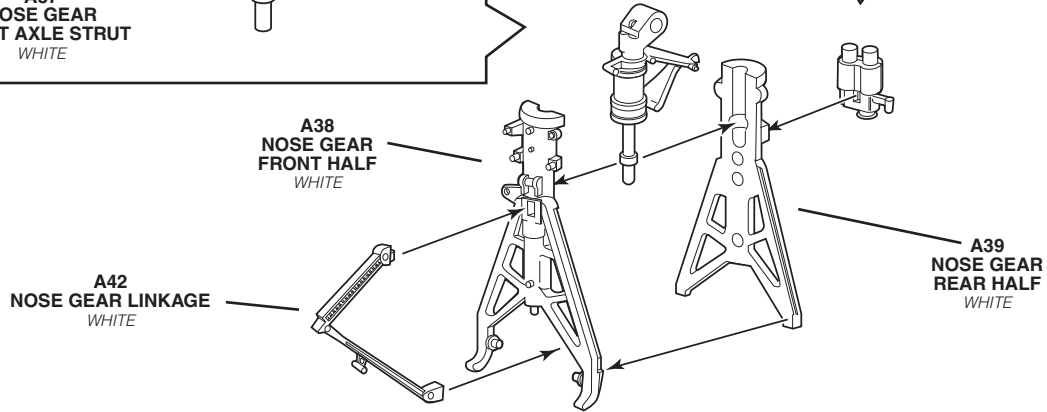
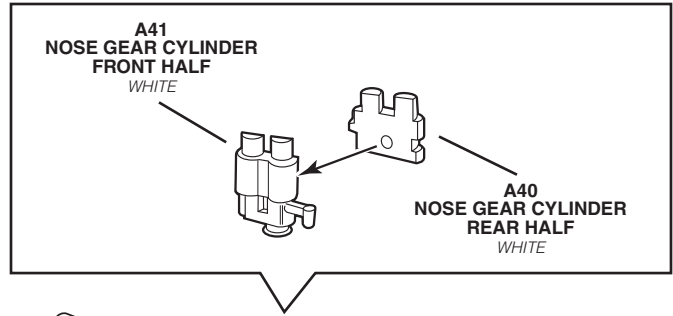
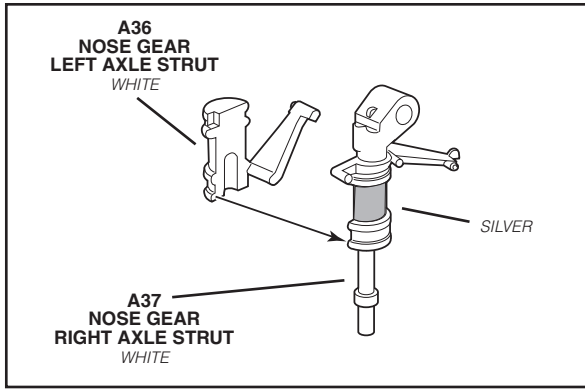

2X

FIRST

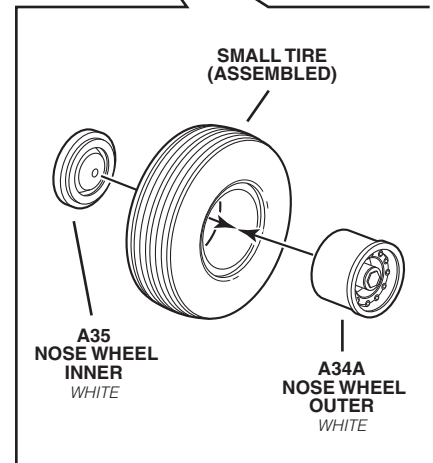
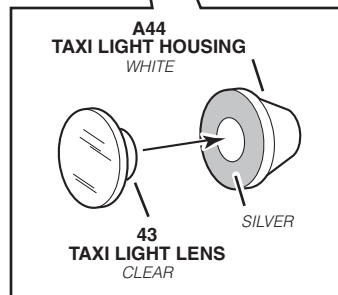
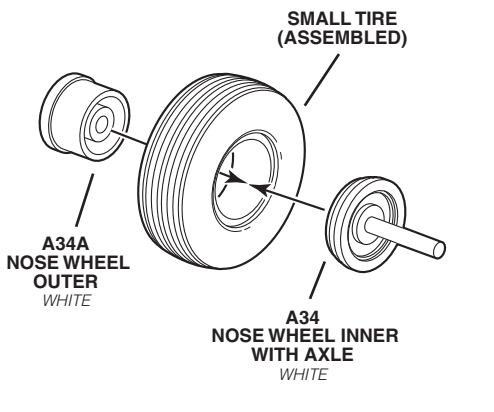
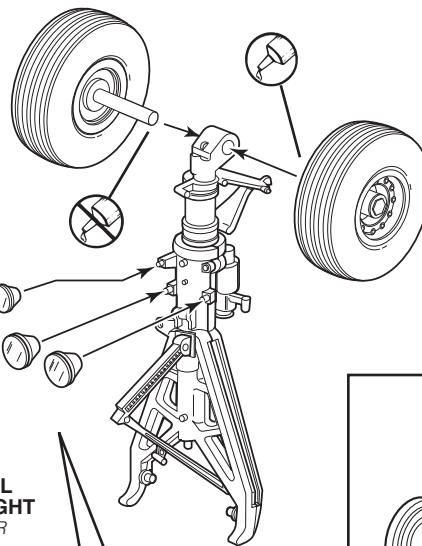
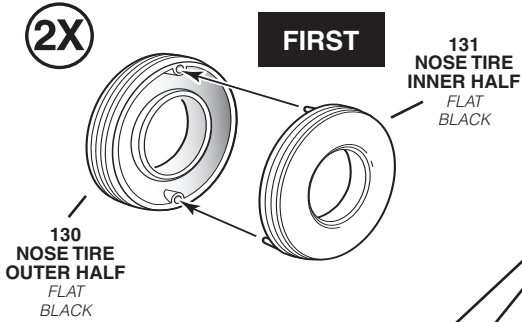

5

NOSE DOOR ASSEMBLY

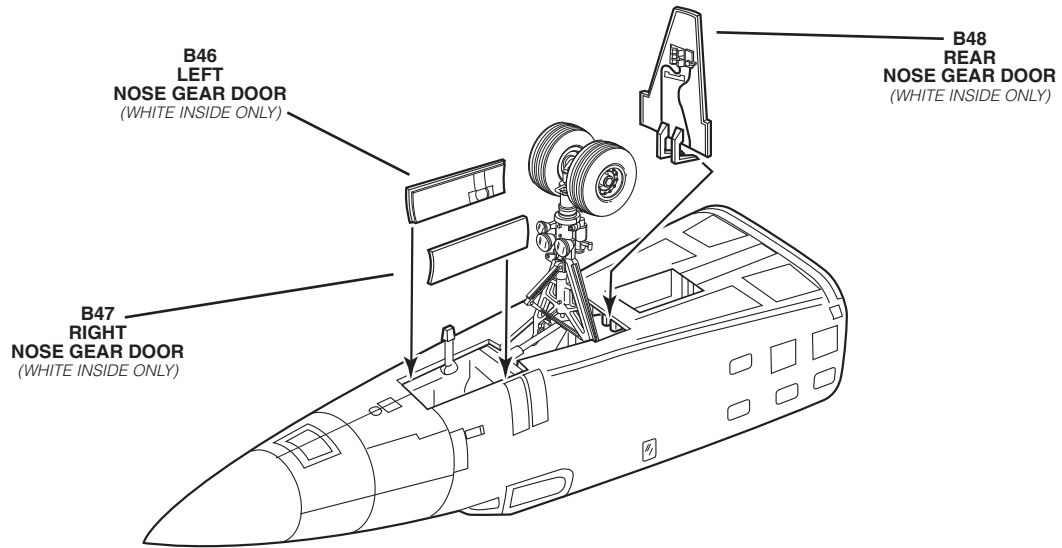

6

SPINDLE / SRAM ASSEMBLY

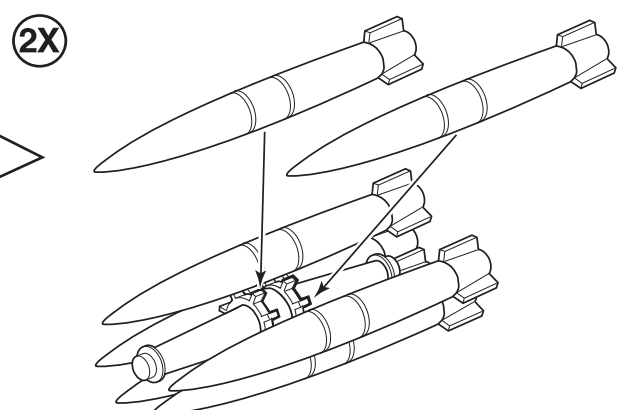
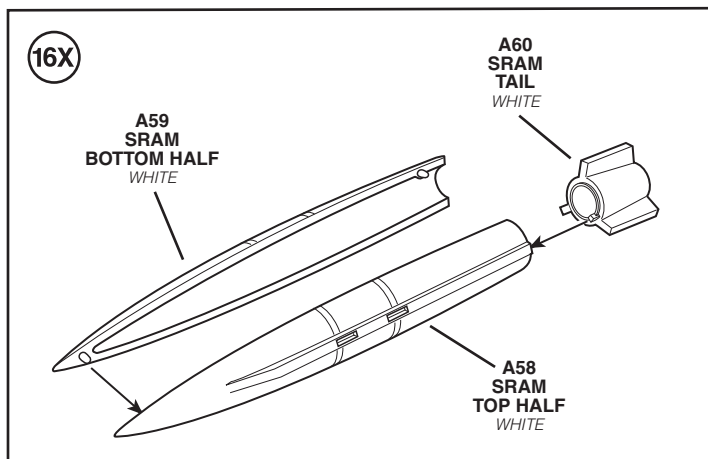
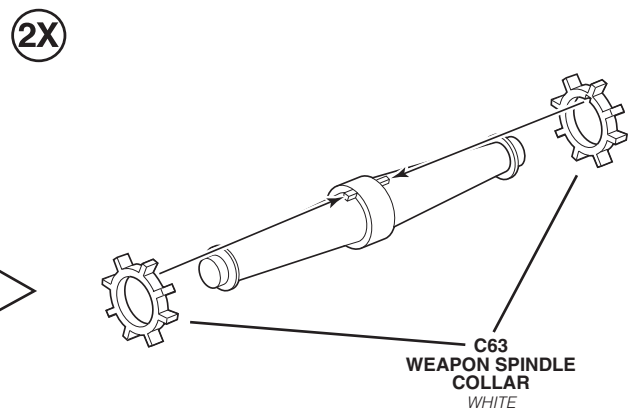
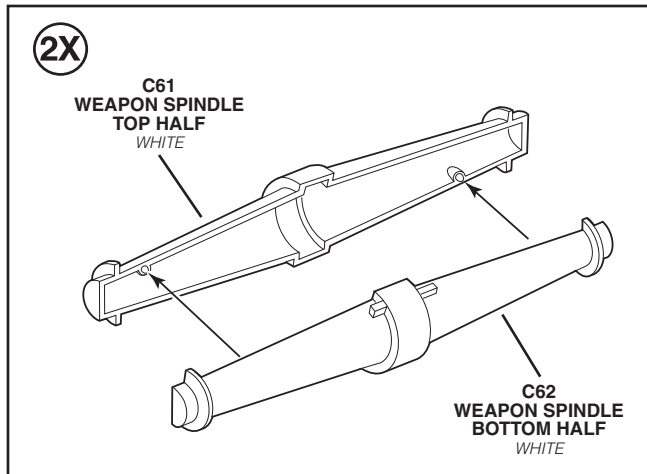

7

BAY ASSEMBLY

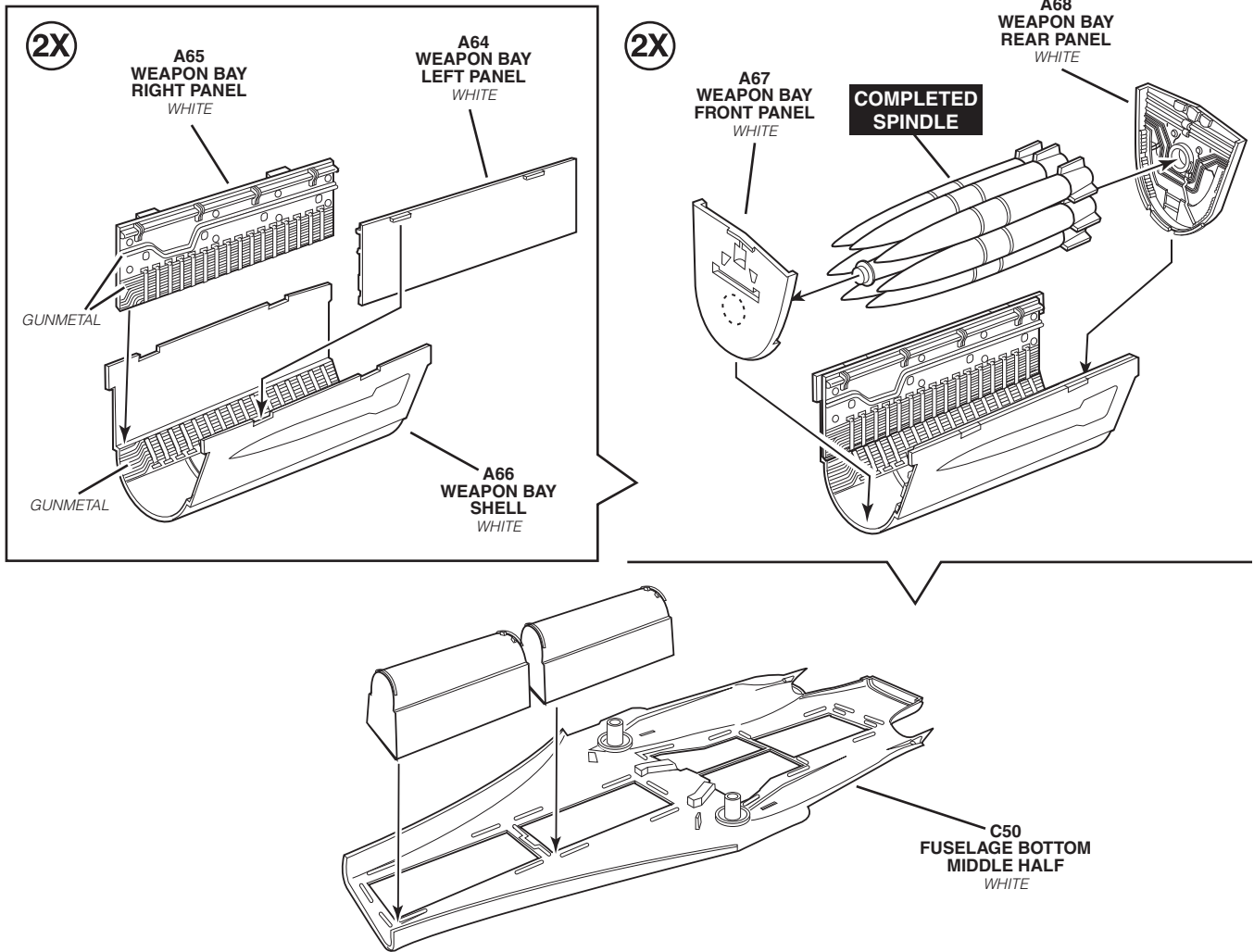

8

MAIN GEAR BAY ASSEMBLY

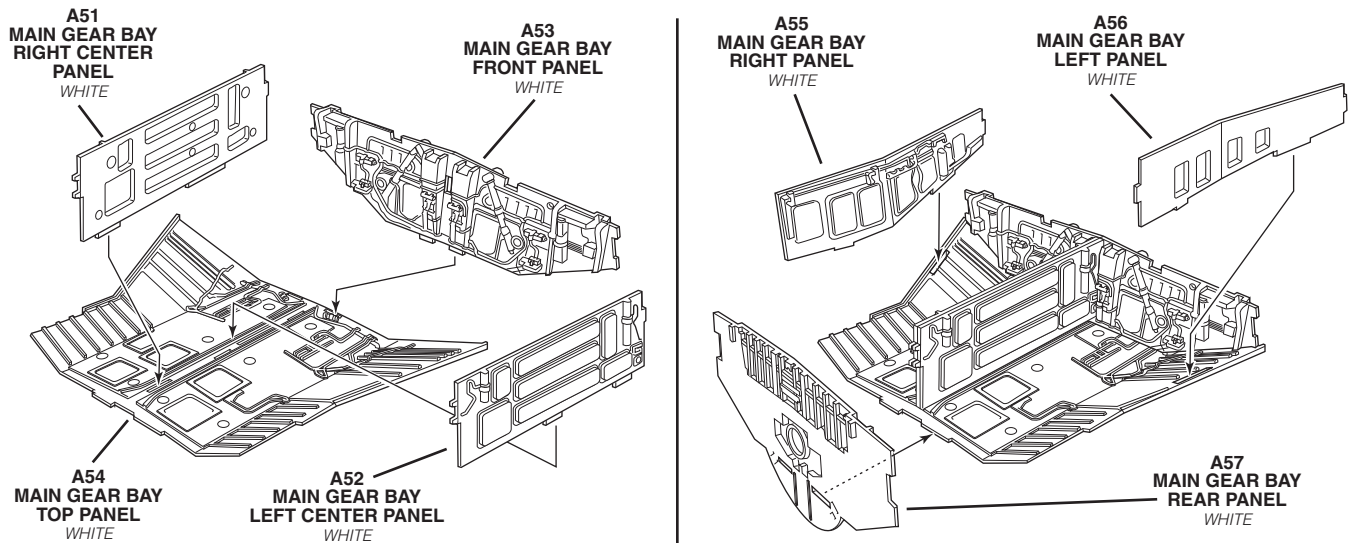

9

FUEL TANK / MAIN BAY ASSEMBLY

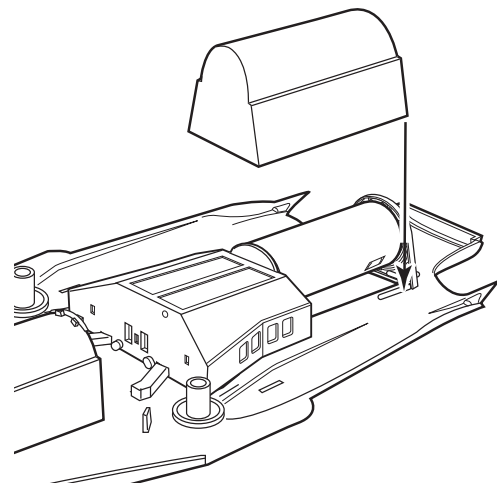
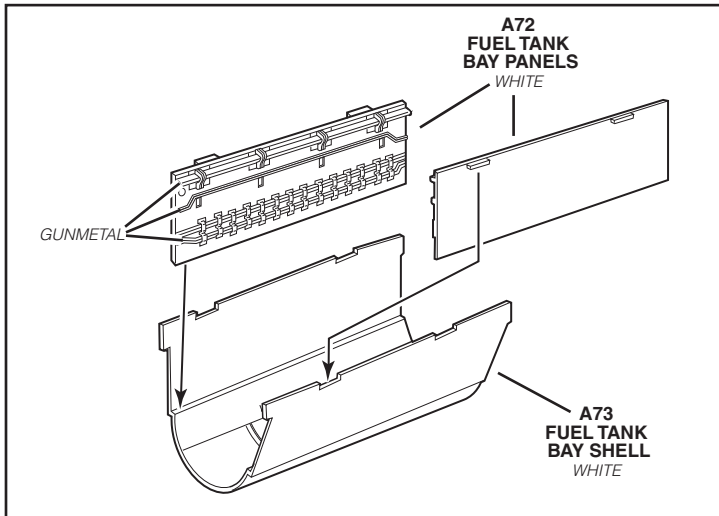
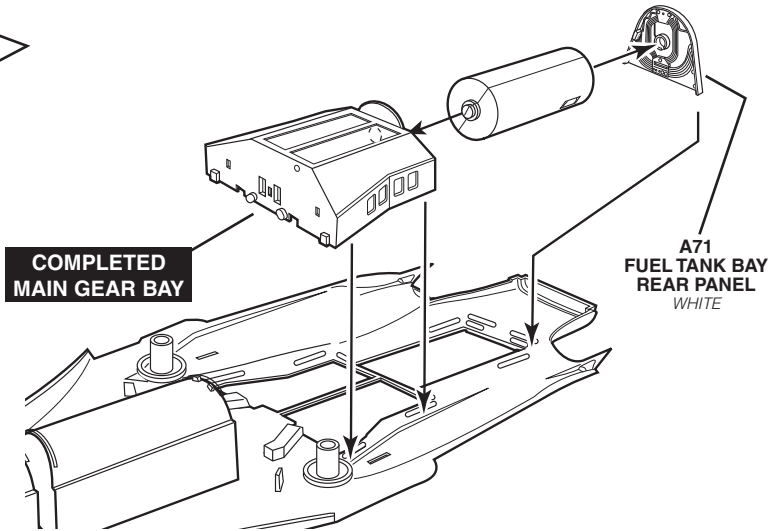
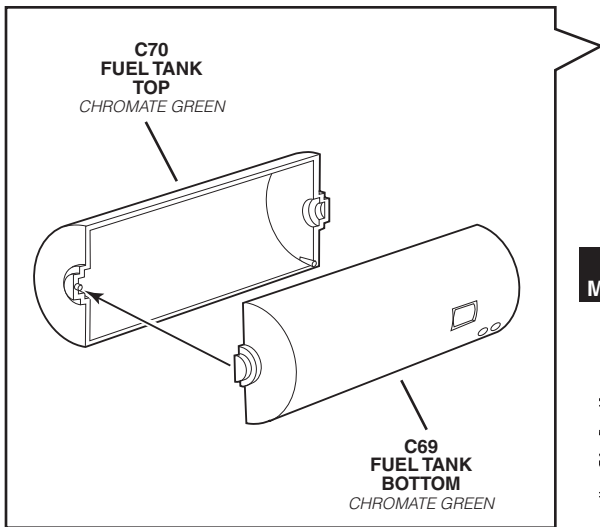

10

WING ASSEMBLY

RIGHT

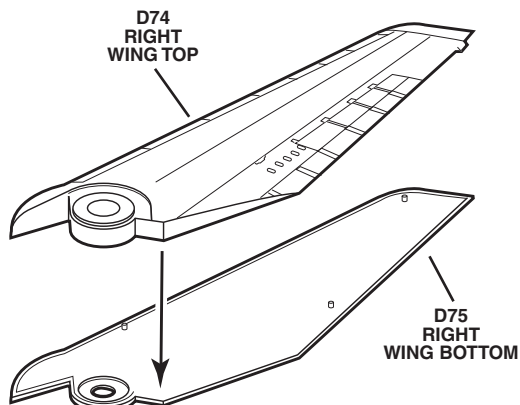

LEFT

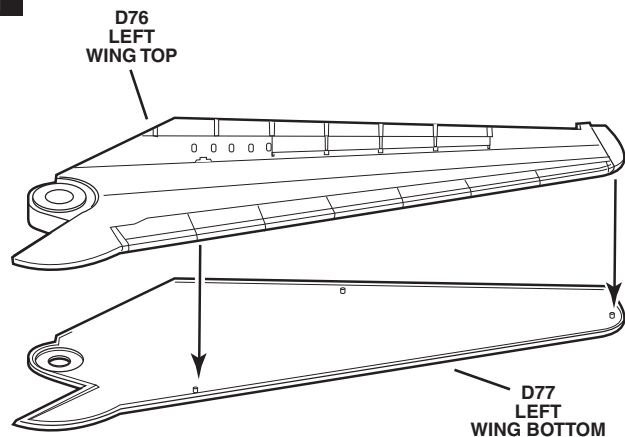

11

WING / FUSELAGE ASSEMBLY

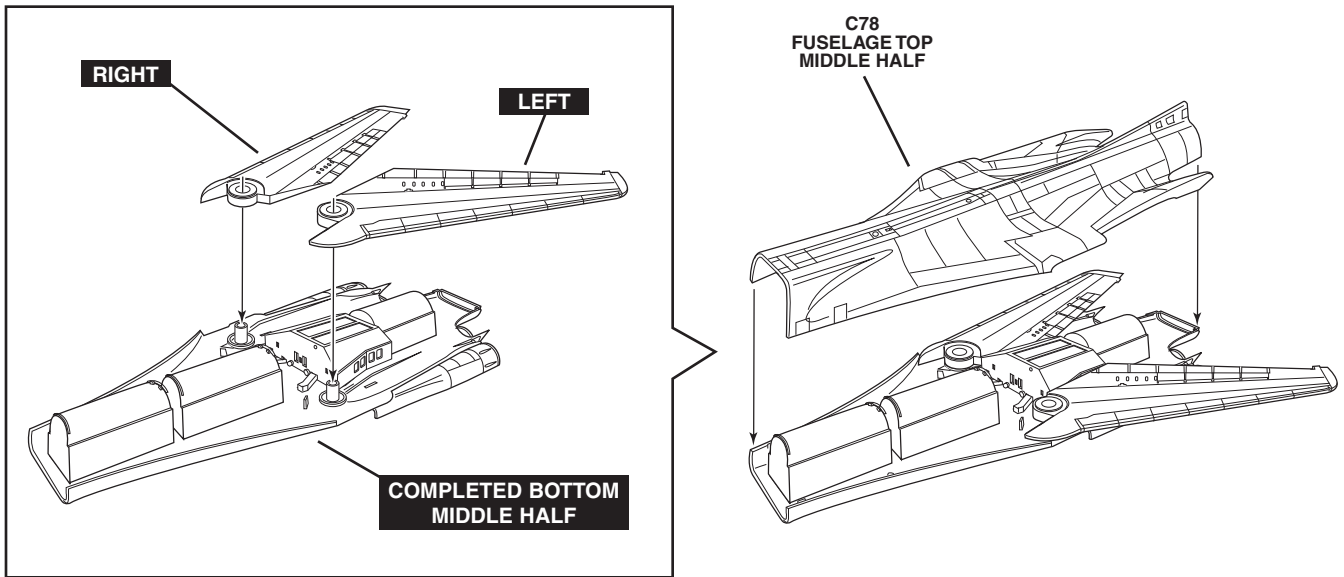

12

NACELLE ASSEMBLY

(2X)

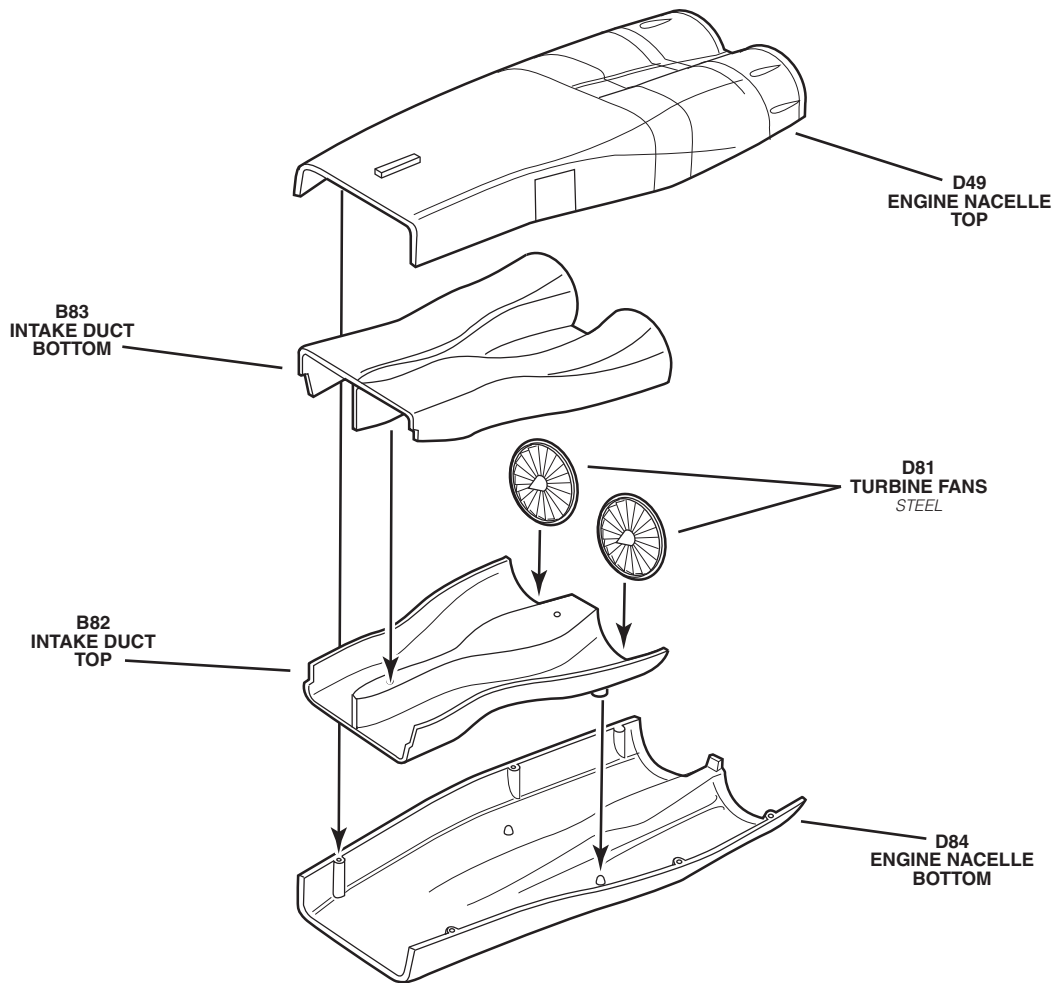

13

EXHAUST ASSEMBLY

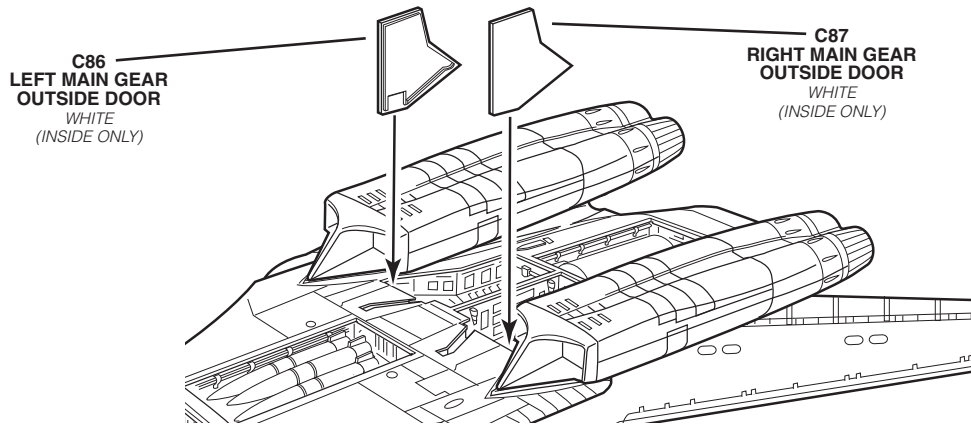
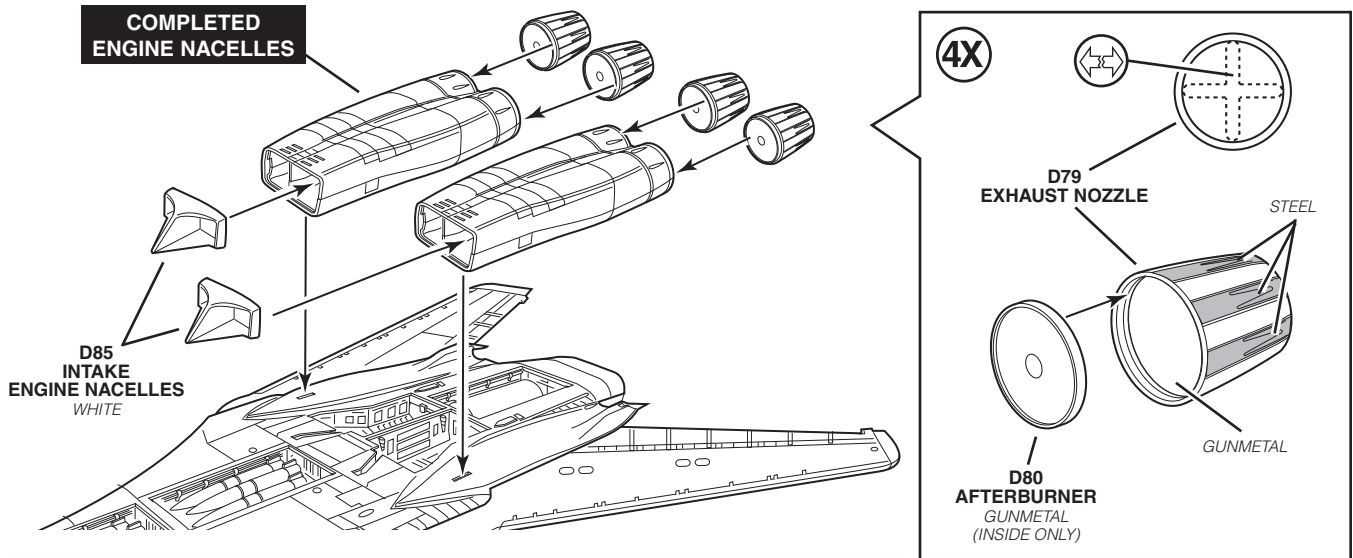

14

RIGHT MAIN STRUT ASSEMBLY

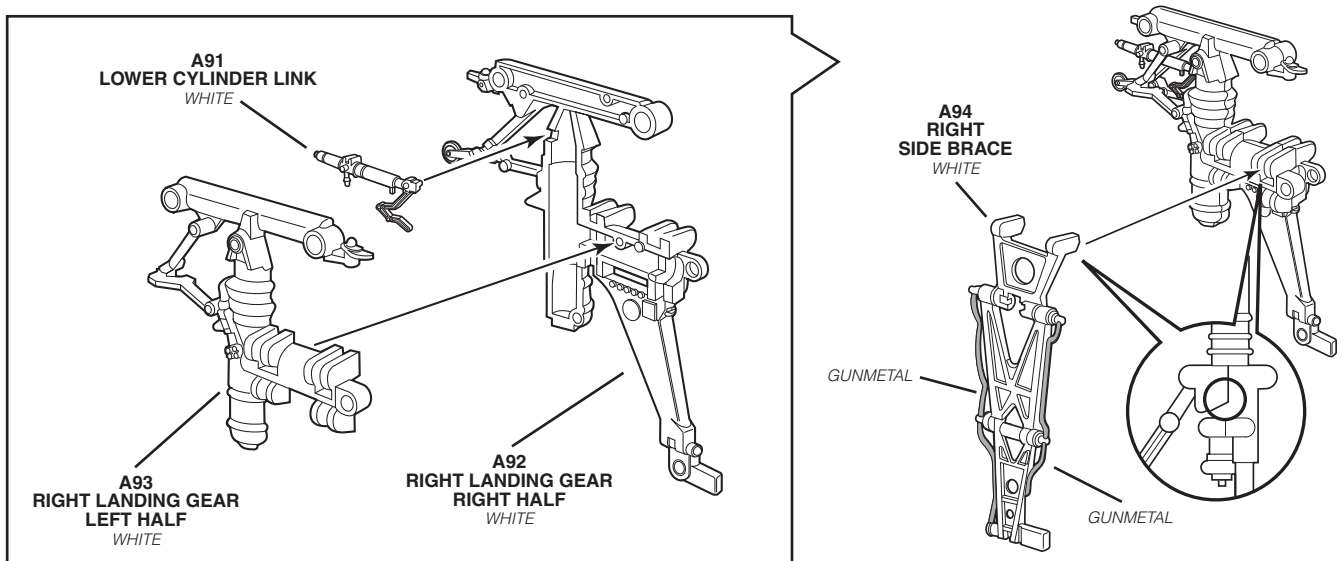

14

RIGHT STRUT ASSEMBLY CONTINUED

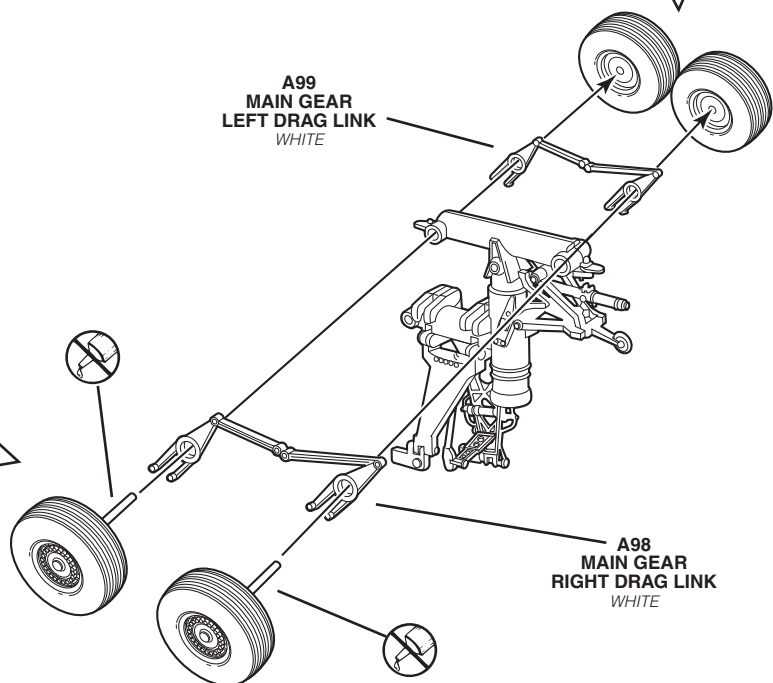
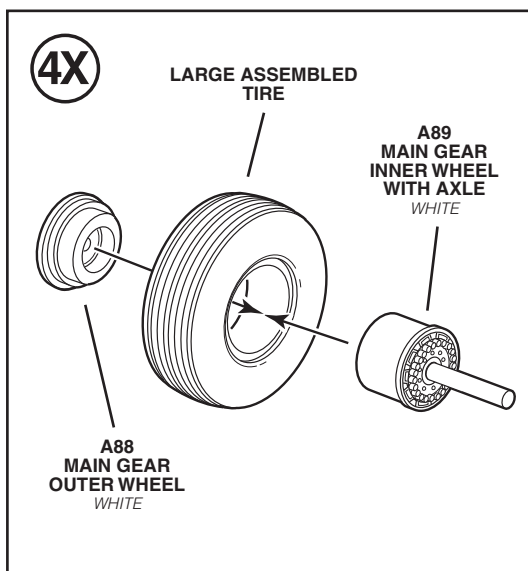
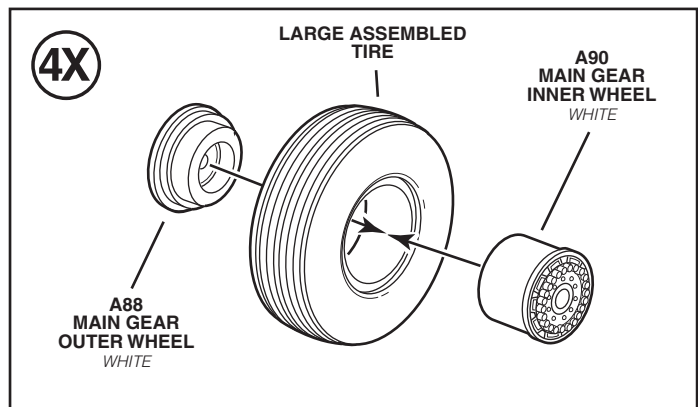
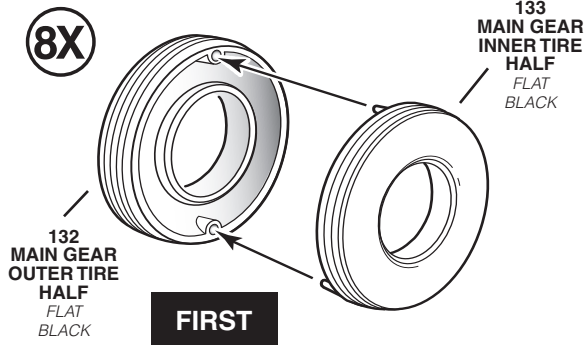
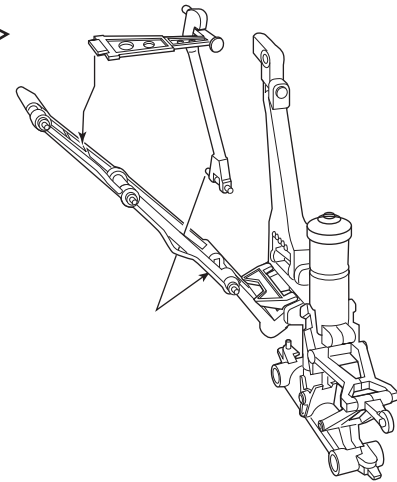
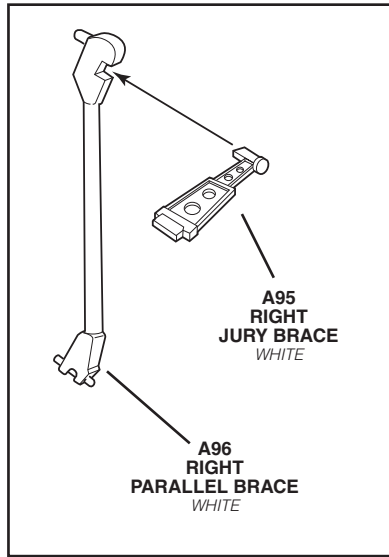
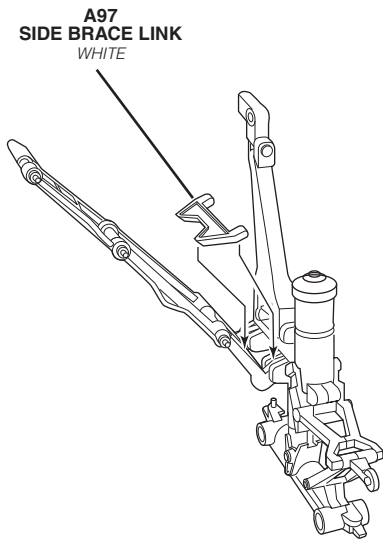

15

LEFT MAIN STRUT ASSEMBLY

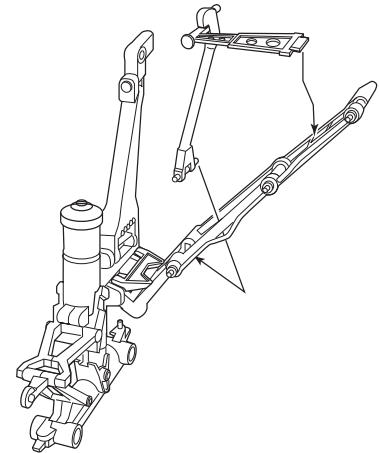
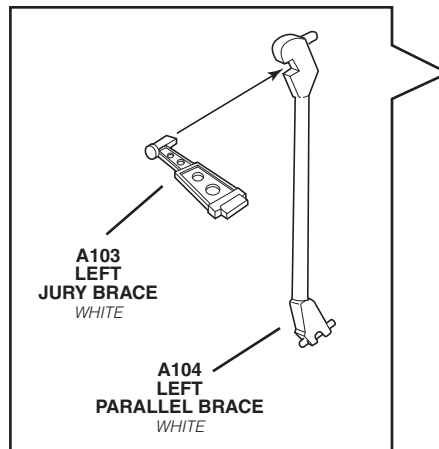
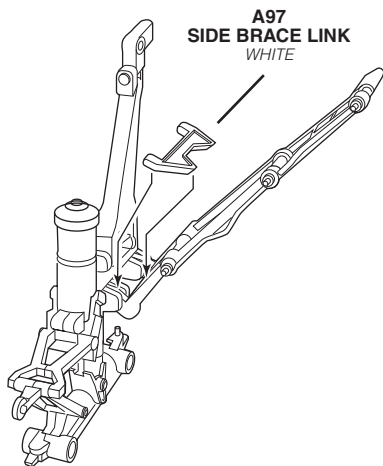
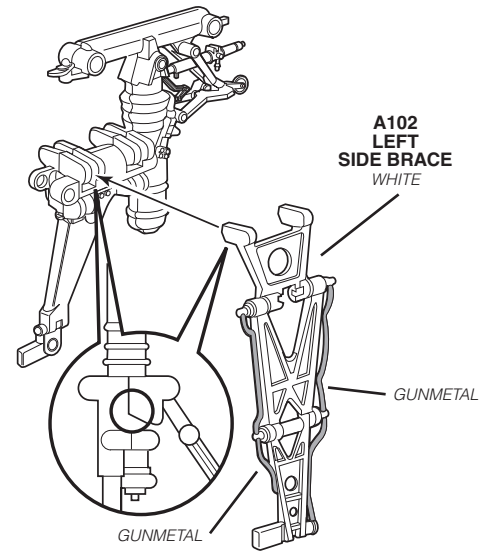
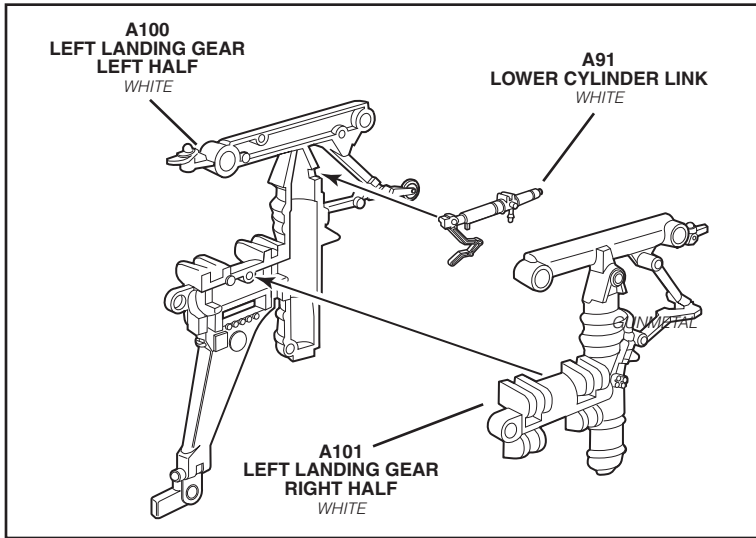

TIRES FROM STEP #14

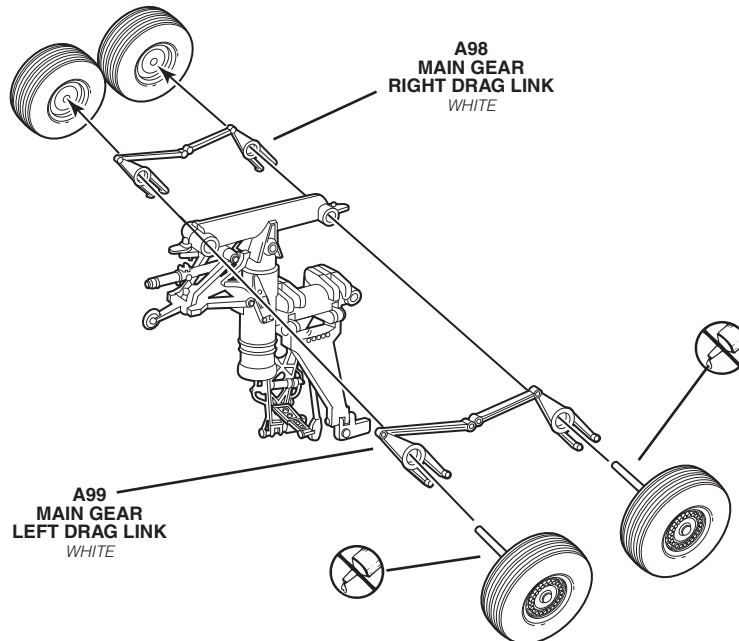

STRUT ASSEMBLY

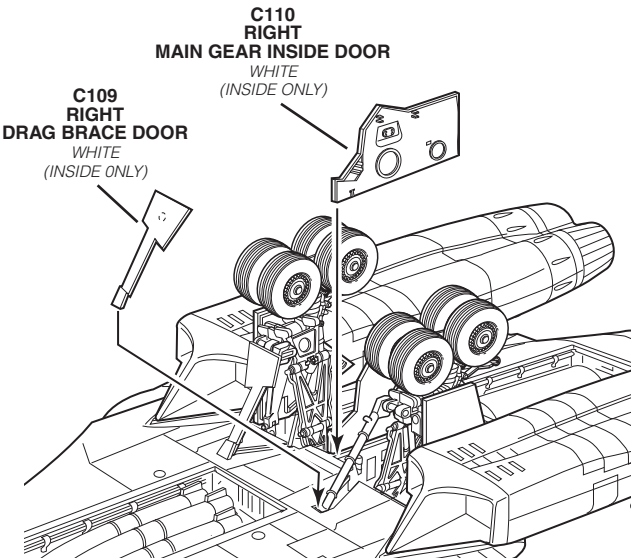
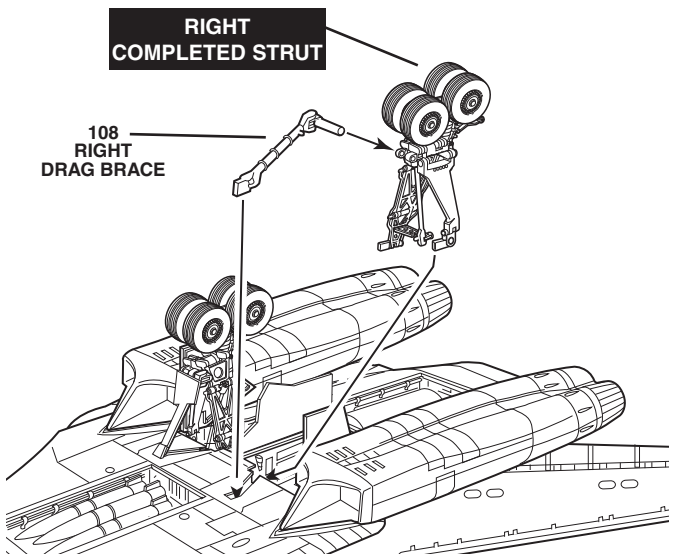
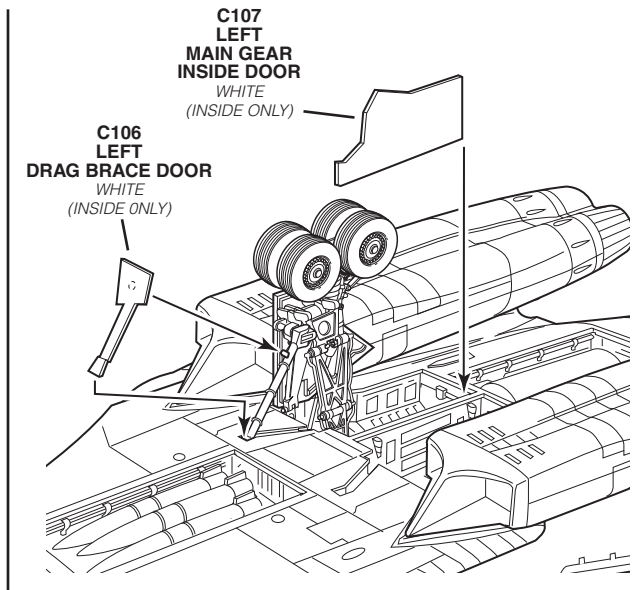
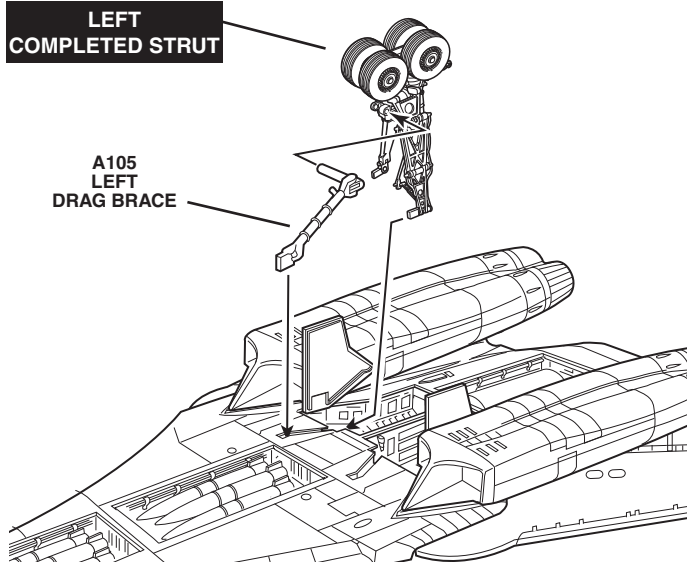

WEAPONS BAY DOOR ASSEMBLY

6X

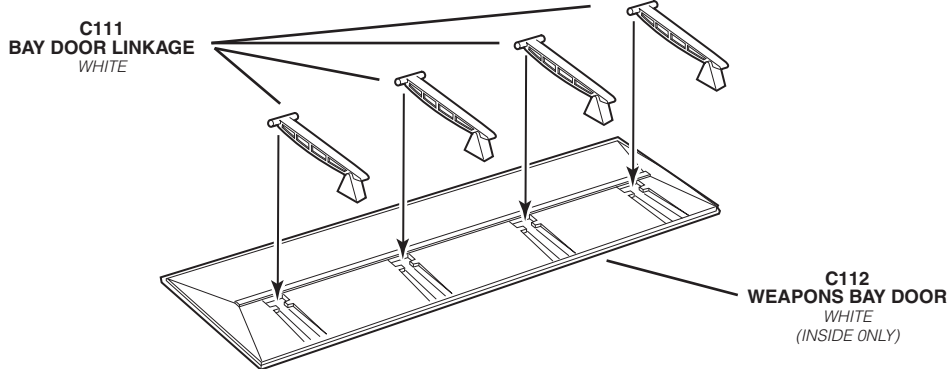

18

BAY DOORS TO FUSELAGE ASSEMBLY

COMPLETED BAY DOORS

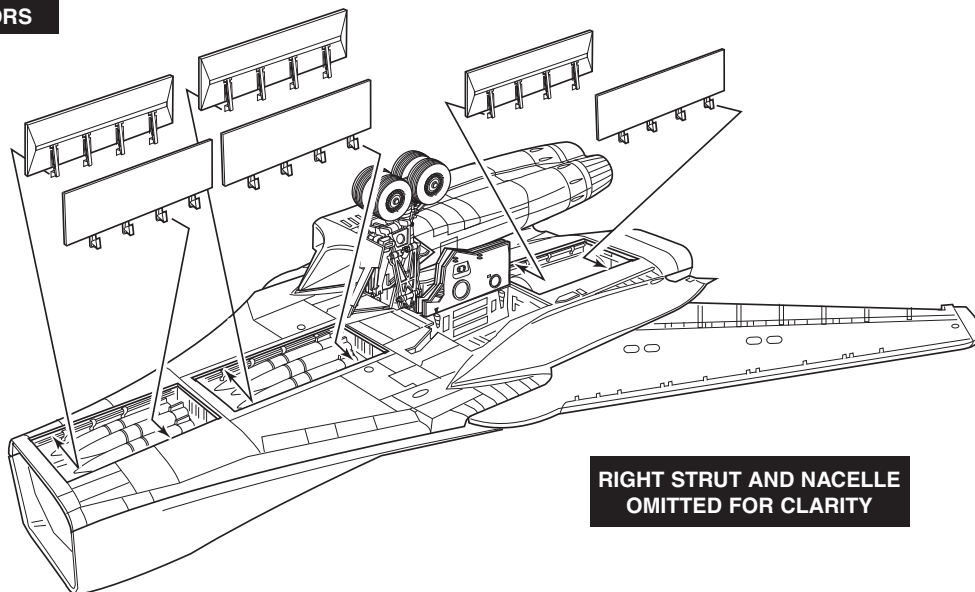

19

REAR FUSELAGE ASSEMBLY

D118
RIGHT
FUSELAGE
REAR HALF

D119
AFT
RADOME

D117
LEFT
FUSELAGE
REAR HALF

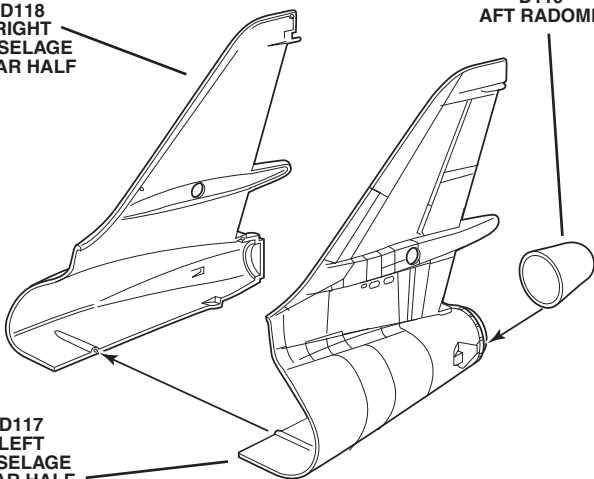

LEFT

D113
LEFT
STABILIZER
TOP

D114
LEFT
STABILIZER
BOTTOM

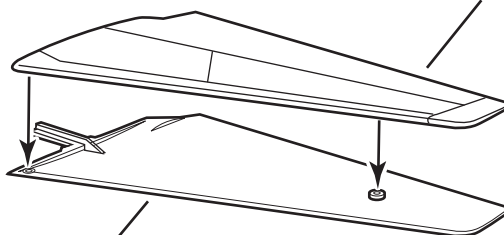

RIGHT

D115
RIGHT
STABILIZER
TOP

D116
RIGHT
STABILIZER
BOTTOM

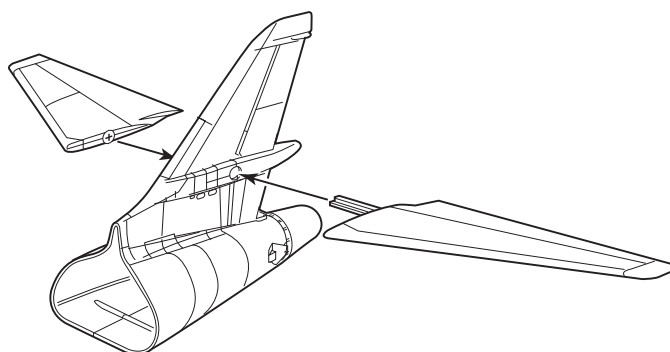
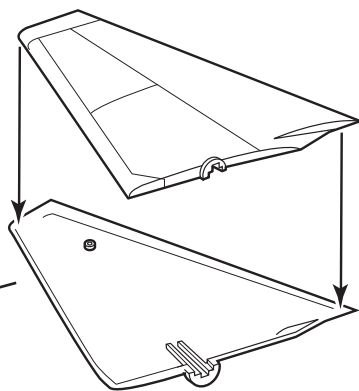

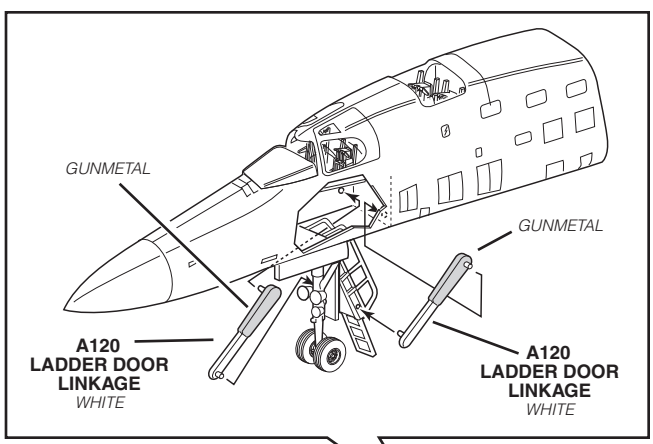

FRONT FUSELAGE

