

B-29 Superfortress

The B-29 "Superfortress" that first took flight on September 21, 1942, was the culmination of a war department request issued to aircraft manufacturers in January 1940. Production of the B-29 would become the single largest aircraft program of the war, and when production ceased nearly 4000 aircraft had been delivered to the USAAF.

With its' wingspan over 141 feet, its' length of 99 feet and its' four 2,200 horsepower engines, this "Superbomber" designed by the Boeing aircraft company would be in service with 61 (VH) Very Heavy Bombardment squadrons when the war ended.

The island hopping campaign developed by the war department was designated to liberate strategically located islands from the Japanese. These islands would become home to the airfields of the vast airborne armada of B-29 "Superfortresses".

Although initially deployed to remote airfields in China and India. The liberation of the Marianas Islands during the summer of 1944 signaled the beginning of the massive "Superfortress" build-up. Operating from hastily constructed airfields on the islands of Guam, Saipan and Tinian, waves of heavily laden B-29s initiated the strategic bombing campaign that would cripple the Japanese war effort.

On the morning of August 6, 1945 a single specially modified B-29

dropped the world's first nuclear weapon on the city of Hiroshima. Followed by the dropping of another such weapon on the city of Nagasaki, three days later. Following the Japanese surrender, B-29s were retained as the United States premier strategic bomber.

In the summer of 1950, the "Superfortress" returned to combat in the skies over Korea. The first unit to see combat was brought up from Guam to be stationed at Kadena AB on the Island of Okinawa. Other B-29 units were deployed to Yokota AB in Japan. From these bases, the bombers could easily range to any Korean target. The B-29 was in combat shortly after the Korean War started through to the last day of the conflict.

The "Superfortress" was fitted with two pressurized crew compartments that were designed to improve aircrew comfort on the fatiguing long-range missions. Nearly twenty thousand pounds of ordnance could be carried in the two huge bomb bays; four powerful Wright "Cyclone" engines equipped with dual exhaust driven superchargers, were nestled in streamlined nacelles. The "Superforts" were heavily armed with ten machine guns mounted in four remote controlled turrets and two additional machine guns and a twenty-millimeter cannon (deleted on later aircraft) were fitted in the tail of each B-29.



*** REPEAT SEVERAL TIMES**
* A REPETER PLUSIEURS FOIS



*** OPTIONAL PARTS**
* PIECES EN OPTION



*** DECAL**
* DECAL COMANIE



*** ALTERNATIVE ASSEMBLY**
* ENSEMBLAGE ALTERNATIVE



*** CEMENT TOGETHER**
* A COLLER



*** REMOVE AND THROW AWAY**
* A RETIRER ET JETER



*** DO NOT CEMENT**
* NE PAS COLLER

READ THIS BEFORE YOU BEGIN

- * Study the assembly drawings.
- * Each plastic part is identified by a number.
- * In the assembly drawings, some parts will be marked by a star (★) to indicate chrome plated plastic.
- * For better paint and decal adhesion, wash the plastic parts in a mild detergent solution. Rinse and let air dry.
- * Check the fit of each piece before cementing in place.
- * Use only cement for polystyrene plastic.
- * Scrape plating and paint from areas to be cemented.
- * Allow paint to dry thoroughly before handling parts.
- * Any unused parts may be discarded.

DECAL APPLICATION INSTRUCTIONS

1. Cut desired decal from sheet.
2. Dip decal in water for a few seconds.
3. Place wet decal on paper towel.
4. Wait until decal is movable on paper backing.
5. Place decal in position on model, face up and slide backing away.
6. Press out air bubbles with a soft damp cloth.
7. Milkyness that may appear is for better decal adhesion and will dry clear. Wipe away any excess adhesive.
8. Do not touch decal until fully dry.
9. Allow the decals 48 hours to dry before applying clear coat.

NOTE: Decals are compatible with setting solutions or solvents.

LIRE CE QUI SUIT AVANT DE COMMENCER

- * Etudier les schémas de montage.
- * Chaque pièce en plastique est identifiée par un numéro.
- * Sur les schémas de montage, certaines pièces sont marquées d'une étoile (★) pour indiquer qu'elles sont en plastique chromé.
- * Pour une meilleure prise de la peinture et des autocollants, laver les pièces en plastique avec une solution détergente peu concentrée. Les rincer et les laisser sécher à l'air.
- * Vérifier que chaque pièce s'ajuste bien avant de la coller en place.
- * N'utiliser que de la colle pour polystyrène.
- * Gratter les parties à coller pour enlever le chrome et la peinture.
- * Laisser la peinture bien sécher avant de manipuler les pièces.
- * Toute pièce inutilisée peut être jetée.

DIRECTIVES D'APPLICATION DES AUTOCOLLANTS

1. Découper l'autocollant désiré de la feuille.
2. Tremper l'autocollant dans de l'eau pendant quelques secondes.
3. Placer l'autocollant mouillé sur une serviette en papier.
4. Attendez que l'autocollant puisse être déplacé sur son support en papier.
5. Mettre l'autocollant en position sur le modèle face sur le dessus et faire glisser le support pour l'enlever.
6. Appuyer avec un chiffon doux humide pour éliminer les bulles d'air.
7. La substance laiteuse qui peut apparaître est destinée à améliorer l'adhésion de l'autocollant et devient incolore au séchage. Essuyer pour enlever tout excédent d'adhésif.
8. Ne pas toucher l'autocollant tant qu'il n'est pas bien sec.
9. Laisser l'autocollant sécher pendant 48 heures avant d'appliquer une couche transparente.

REMARQUE: Les autocollants sont compatibles avec les solutions de fixation ou les solvants.

This optional paint guide is provided if you choose to detail paint your model.

Ce guide de peinture vous sera fourni si vous choisissez de peindre votre modèle en détail.

Aircraft Gray	<i>Gris aéronef</i>
Aluminium	<i>Aluminium</i>
Blue	Testors 1110 <i>Bleu</i>
Emerald Green	<i>Vert émeraude</i>
Fiat Black	<i>Noir mat</i>
Fiat Brown	<i>Brun mat</i>
Fiat Dark Green	<i>Vert foncé mat</i>
Fiat White	<i>Blanc mat</i>
Fiat Yellow	<i>Jaune mat</i>
Gloss Black	<i>Noir brillant</i>
Gunmetal	<i>Bronze</i>
Leather	<i>Cuir</i>
Light Gray	FS 16492 <i>Gris clair</i>
Military Brown	<i>Brun milliaire</i>
Olive Drab	<i>Olivet</i>
Red	<i>Rouge</i>
Rubber	<i>Caoutchouc</i>
Silver	<i>Argent</i>
Steel	<i>Acier</i>
Tan	<i>Havane</i>
Wood	<i>Bois</i>
Yellow	FS 13538 <i>Jaune</i>

If you have any questions or comments, call our hotline at: (800) 833-3570 or, please write to:

Revell-Monogram Consumer Service Department, 725 Landwehr Road, Northbrook, Illinois 60062

Be sure to include the plan number (85571100200), part number, description, your return address and phone number.

Visit our website: www.revell-monogram.com

1

FLIGHT DECK ASSEMBLY

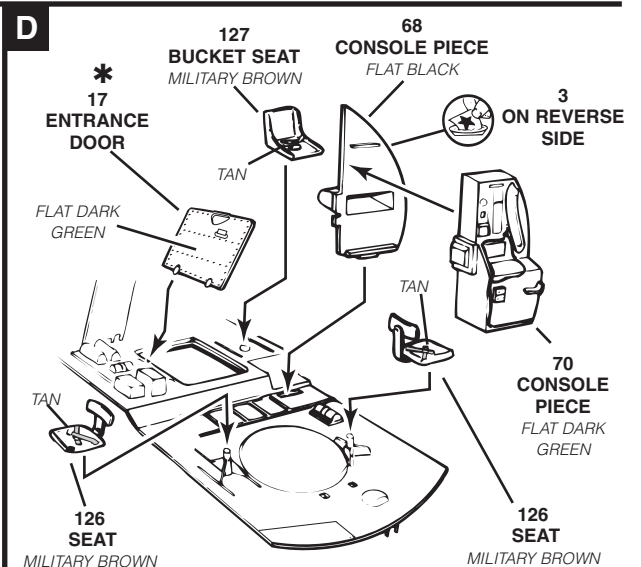
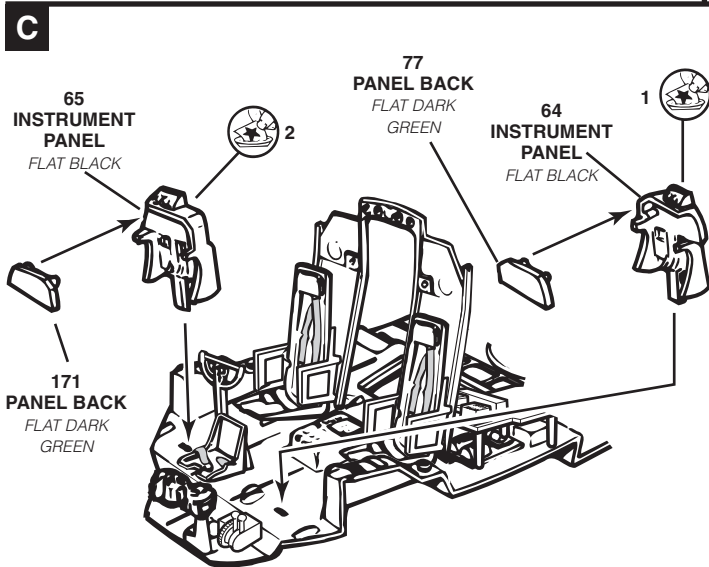
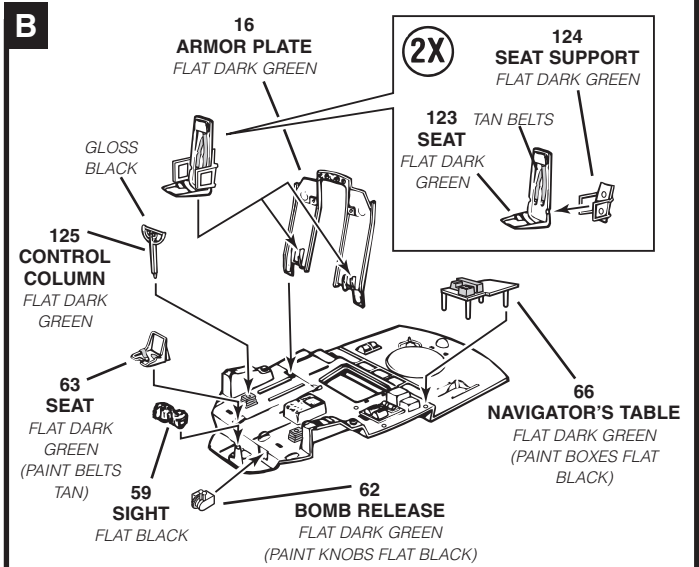
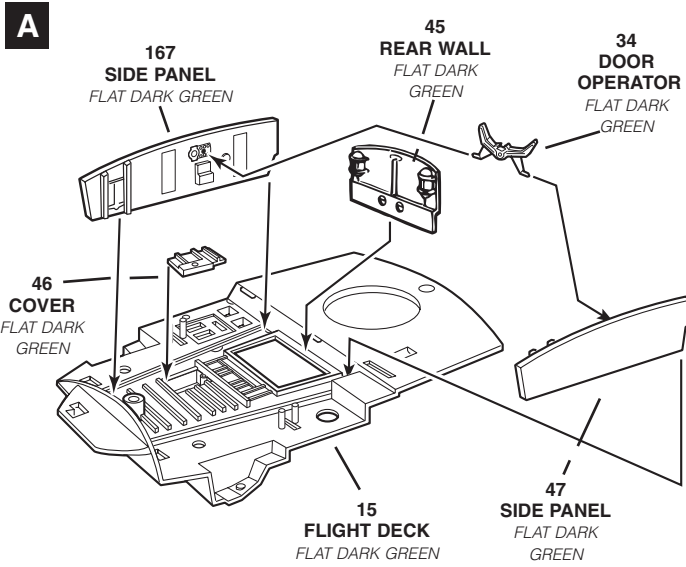

* NOTE: DOOR (17) OPEN ON GROUND, CLOSED IN FLIGHT

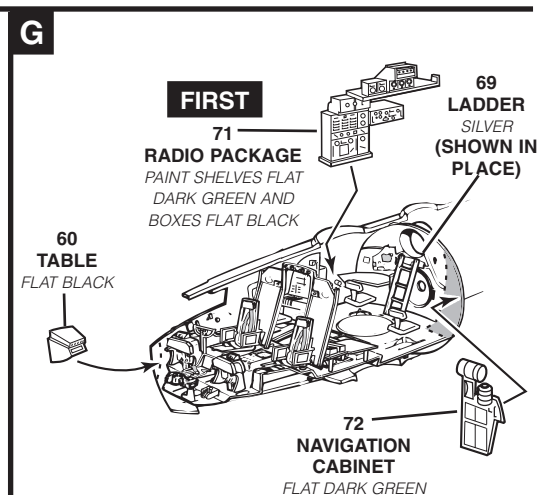
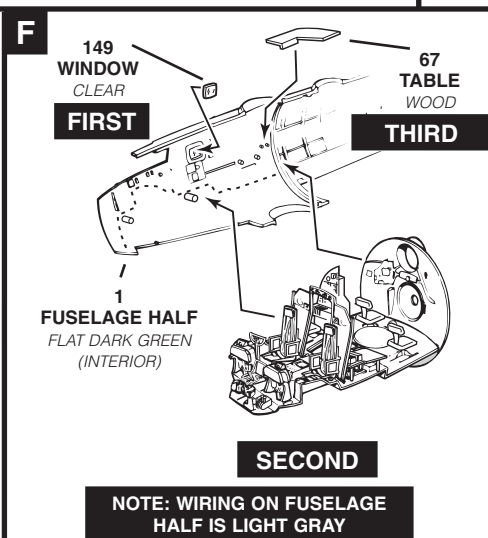
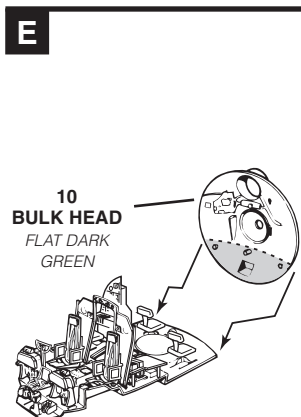

2

INTERIOR ASSEMBLY

A

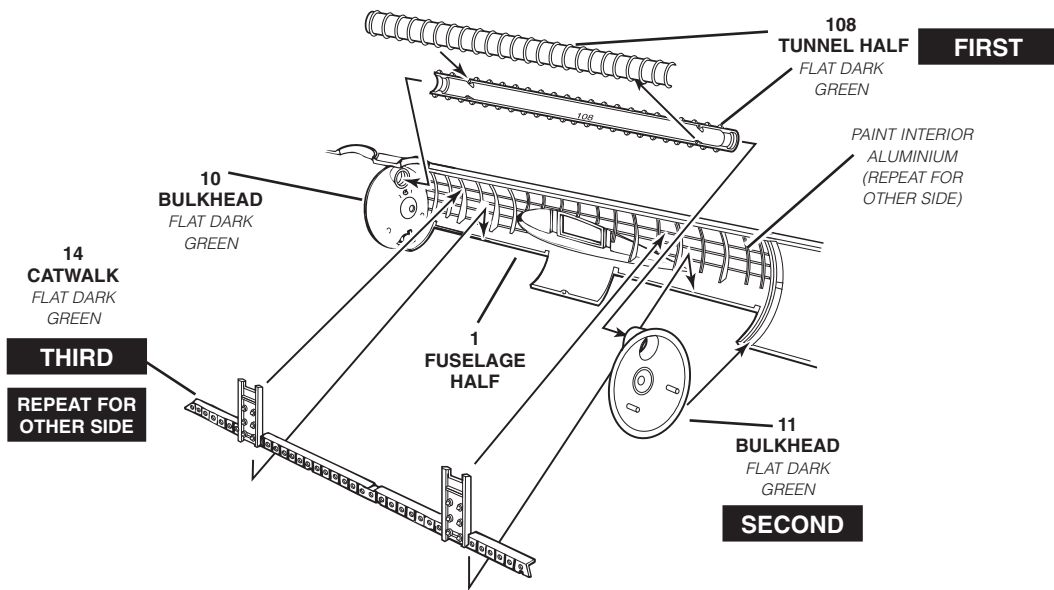

B

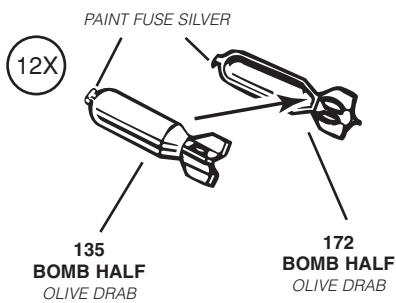

C

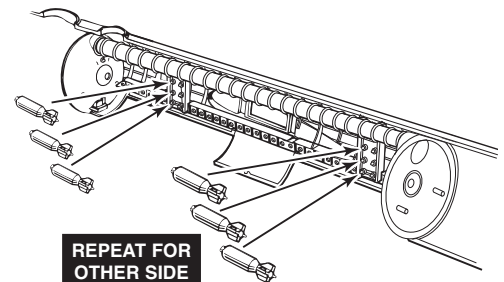

D

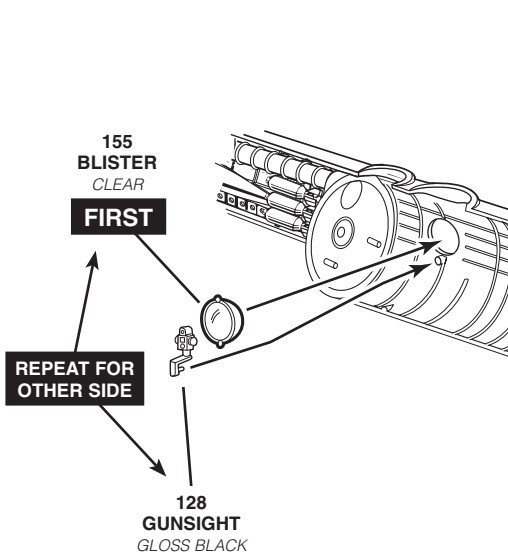

E

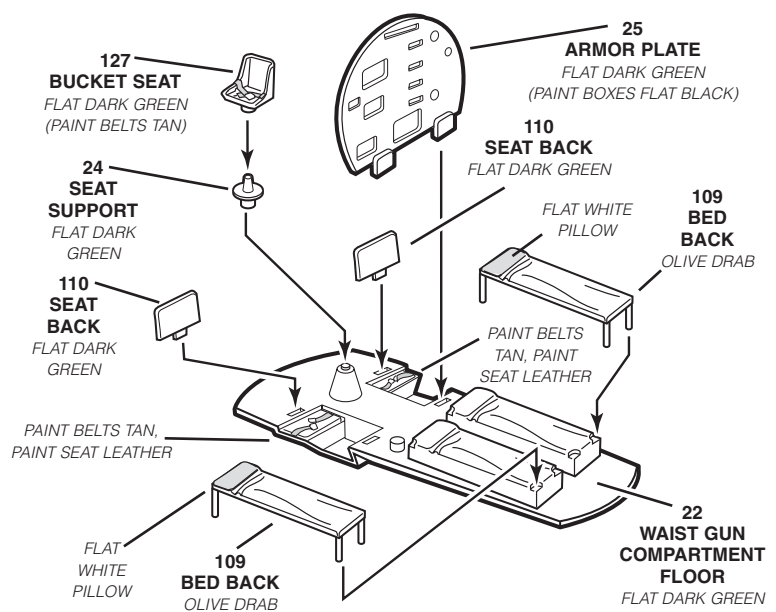

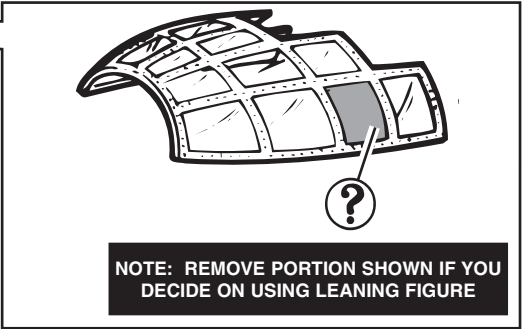
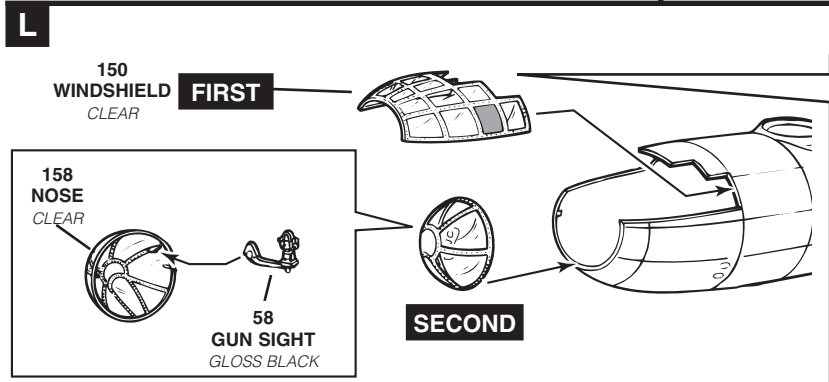
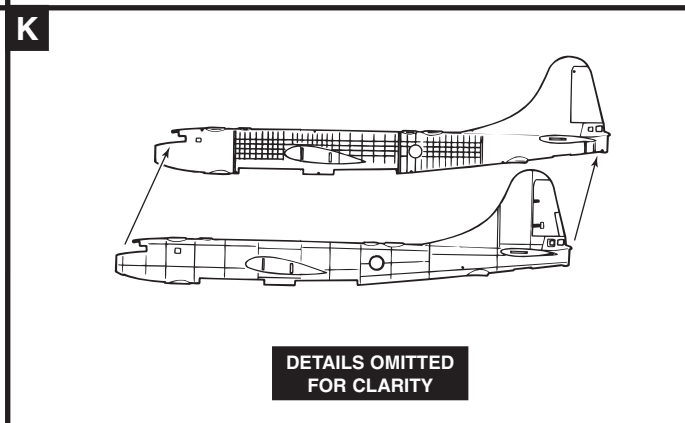
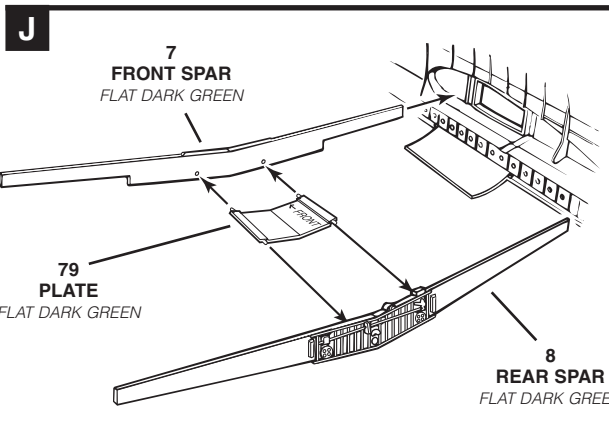
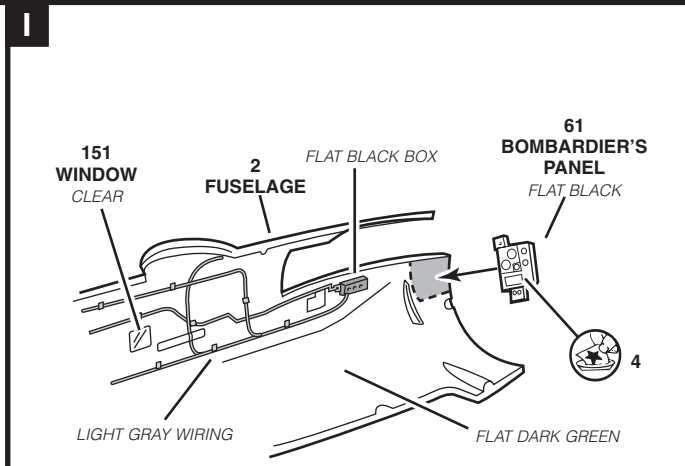
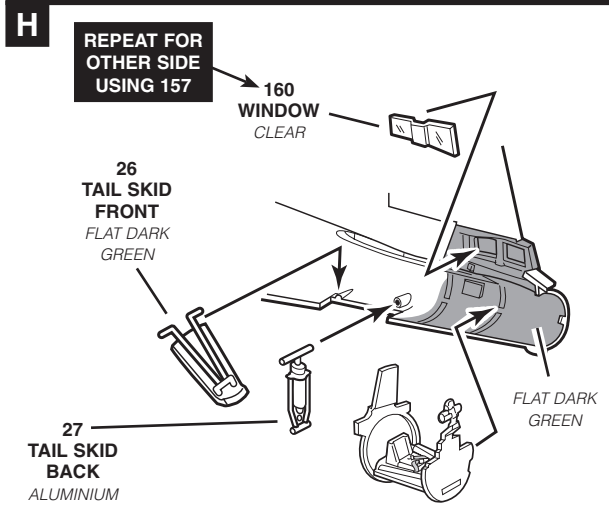
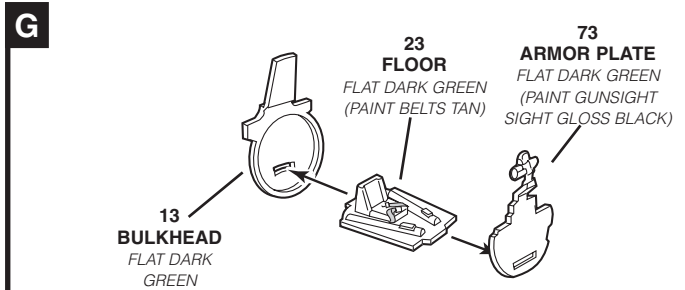
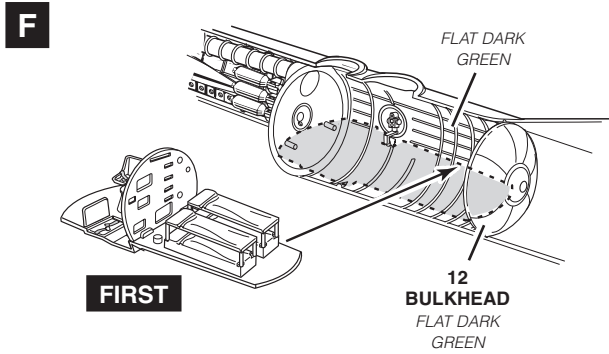

3

TAIL AND WING ASSEMBLY

A

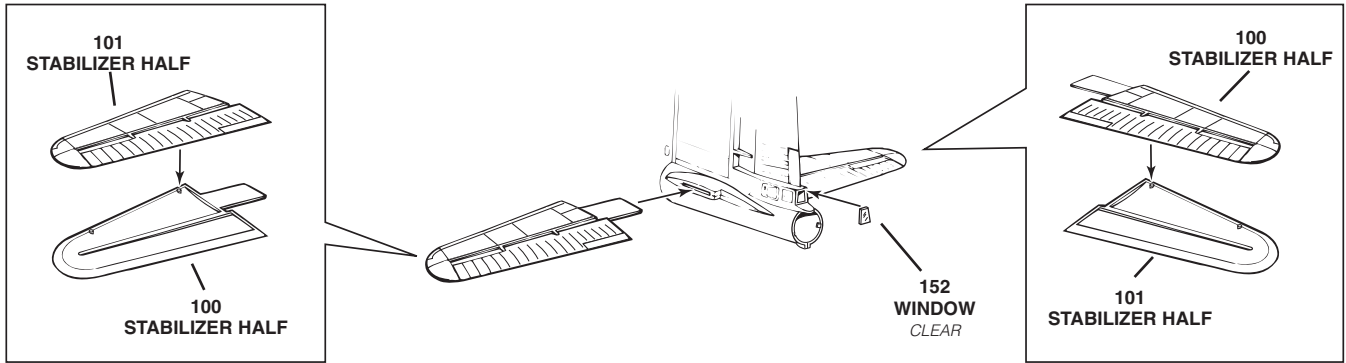

B

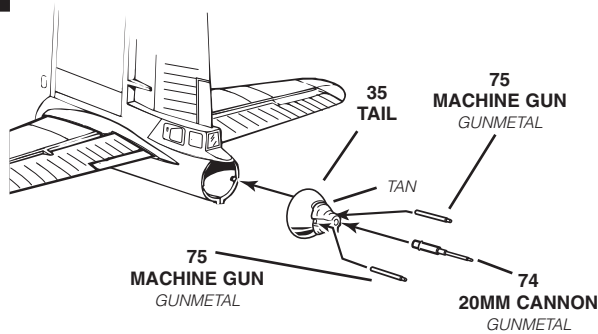

C

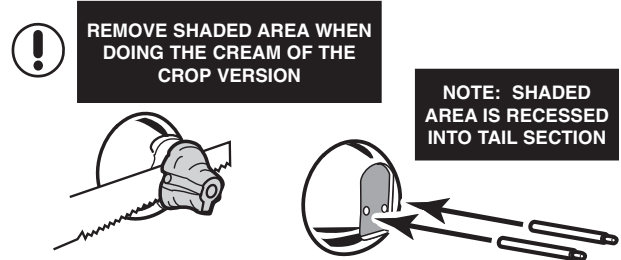

D

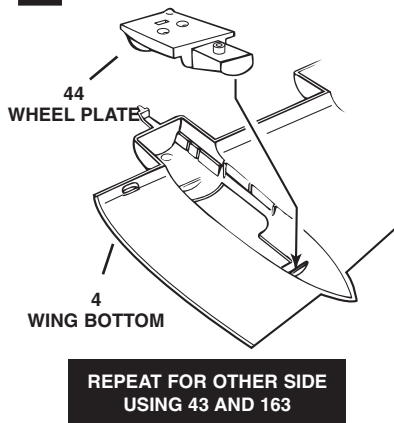

E

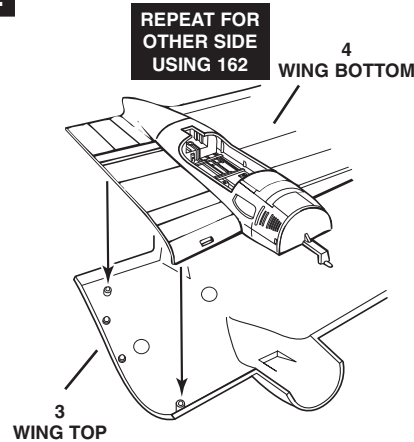

F

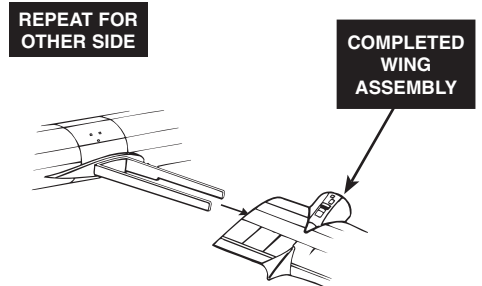

G

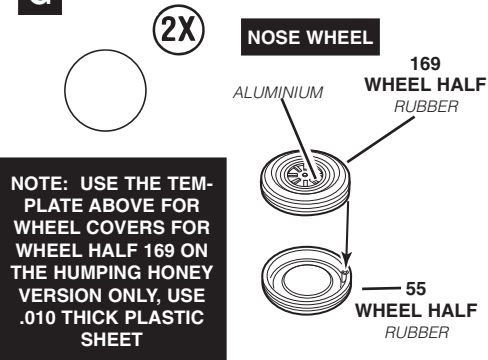

H

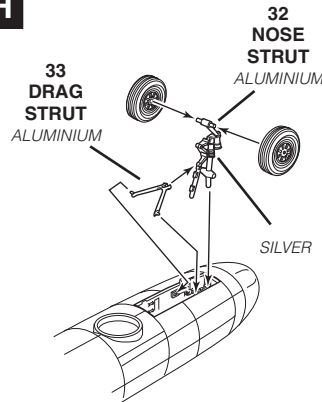

I

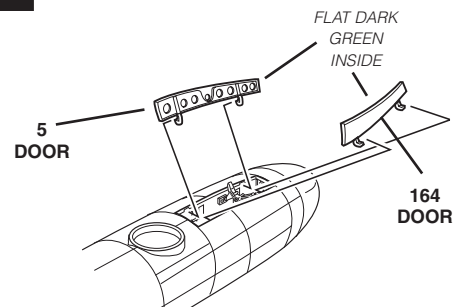

4

WHEEL AND DOORS ASSEMBLY

A

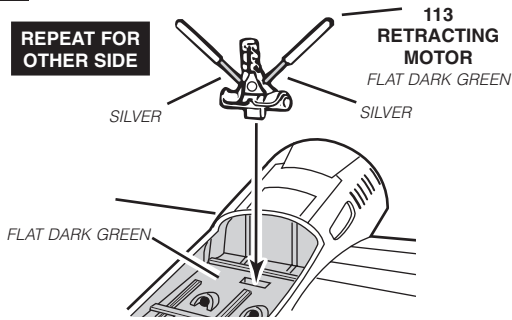

B

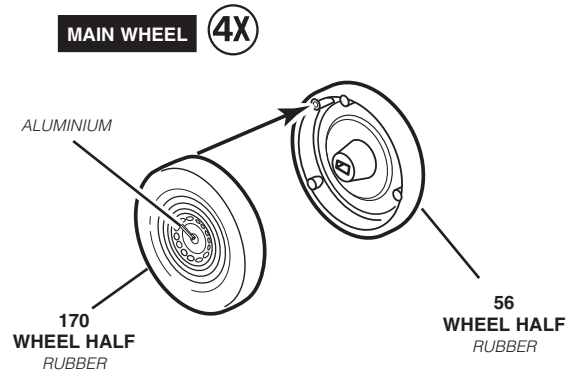

C

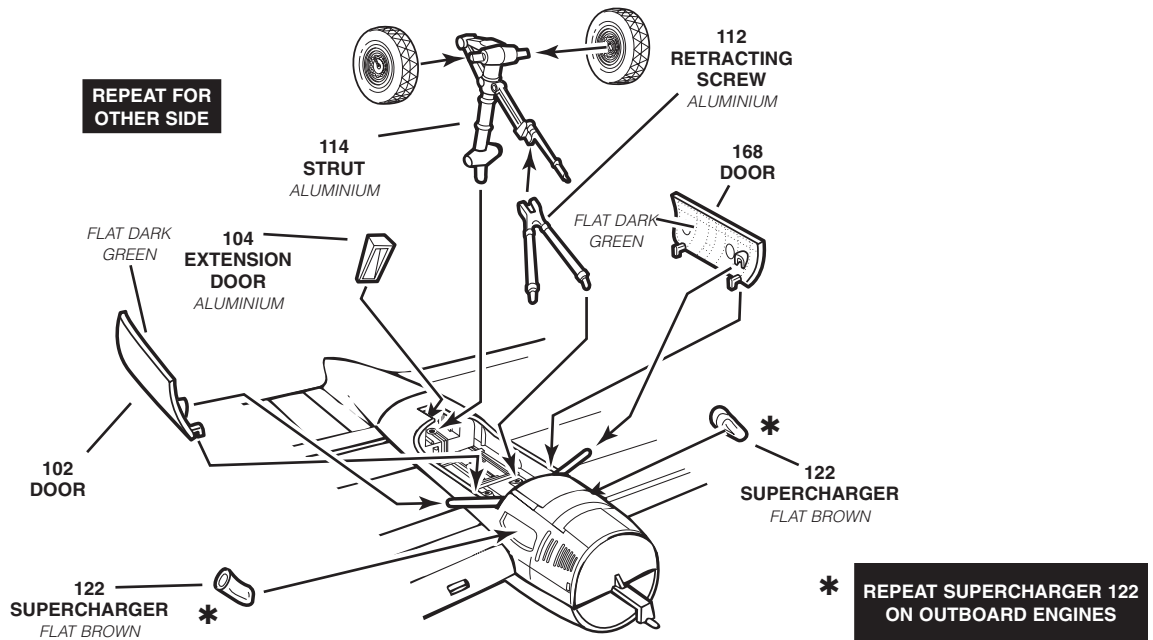

D

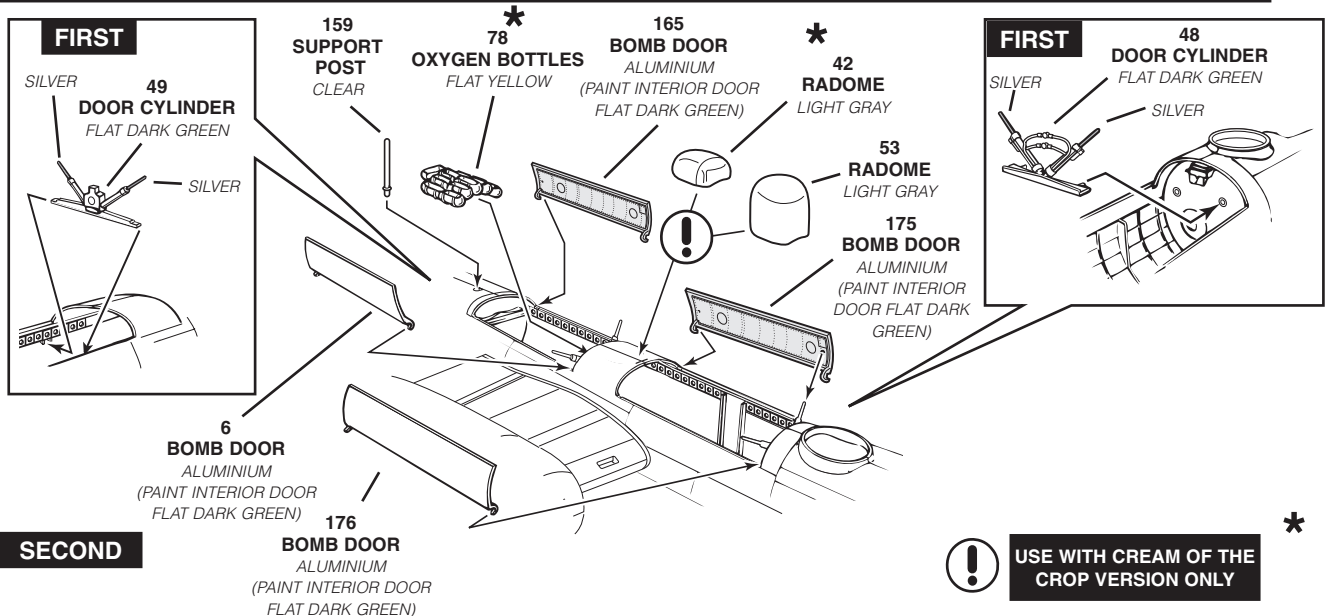

5

BODY ASSEMBLY

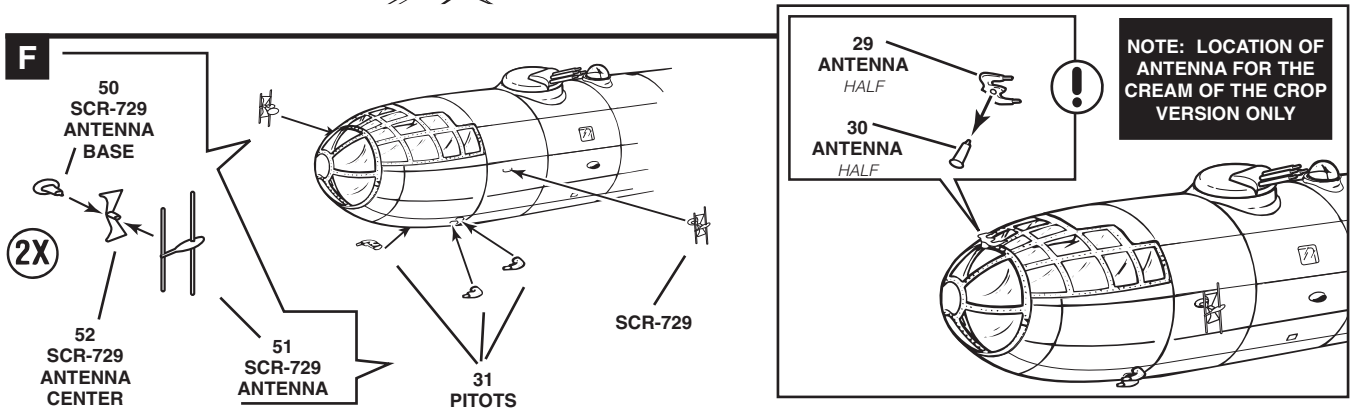
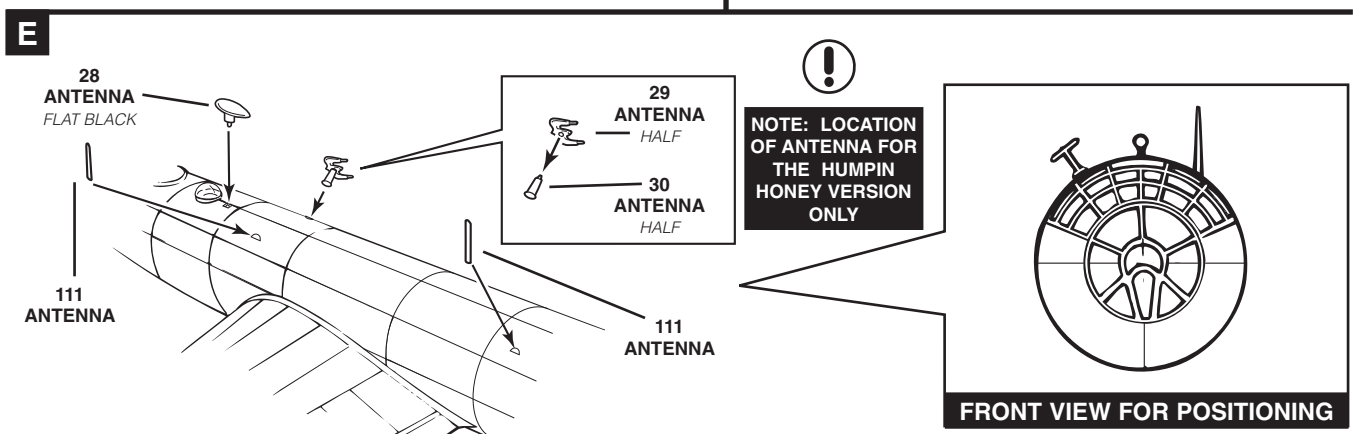
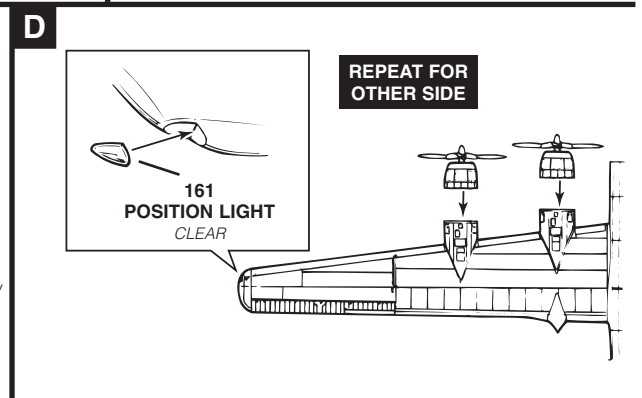
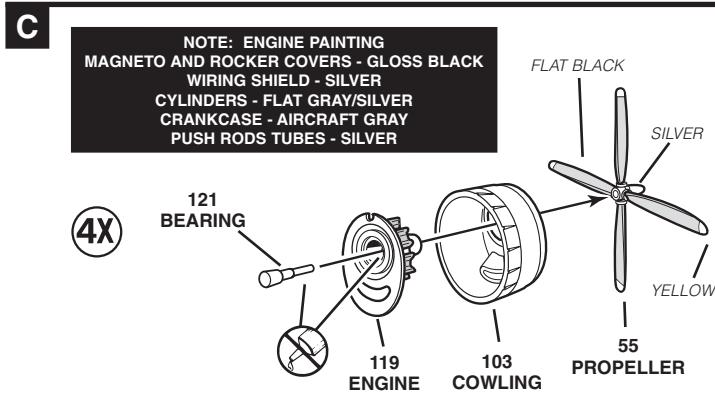
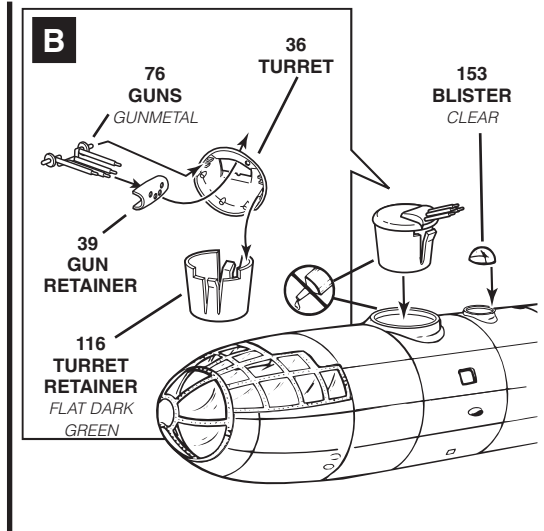
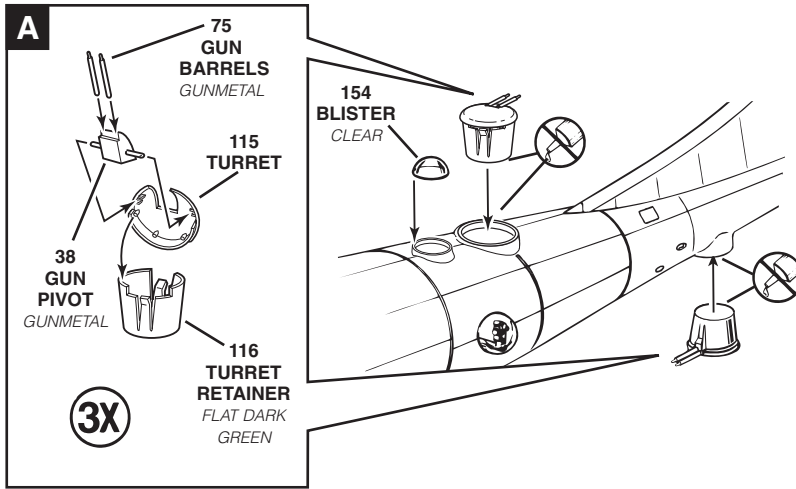



**BOEING B-29A-5-BW HUMPIN HONEY, 462ND BOMBARDMENT GROUP
770TH BOMBARDMENT SQUADRON, CHENGCTU, CHINA, JULY, 1944**

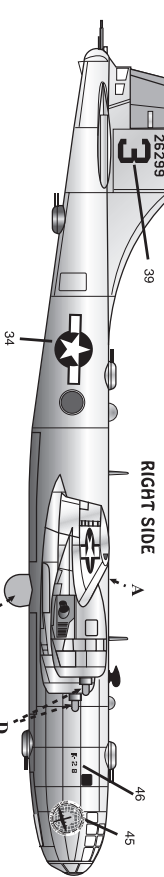
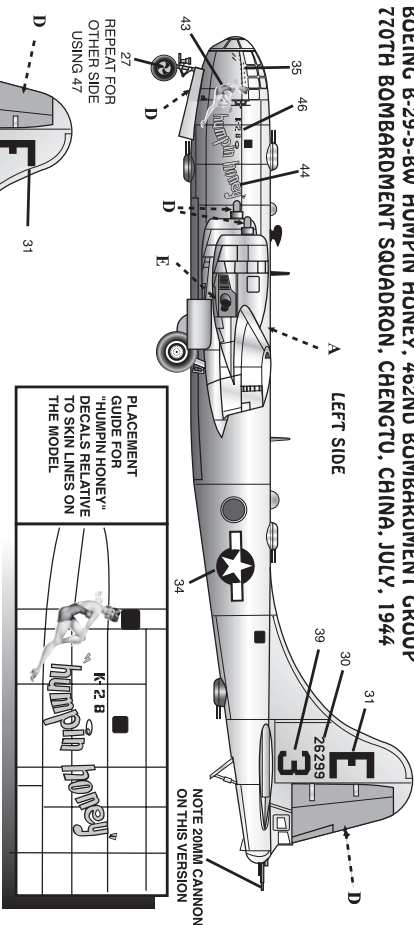

**BOEING B-29A-40-BN, CREAM OF THE CROP, 19TH BOMBARDMENT GROUP
30TH BOMBARDMENT SQUADRON, KADENA AIR FORCE BASE,
GUAM, 1951.**

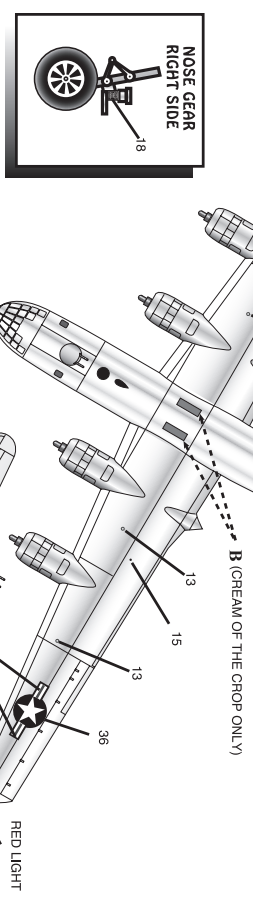
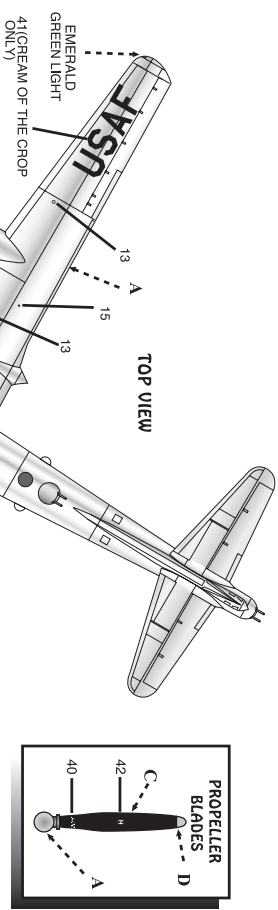
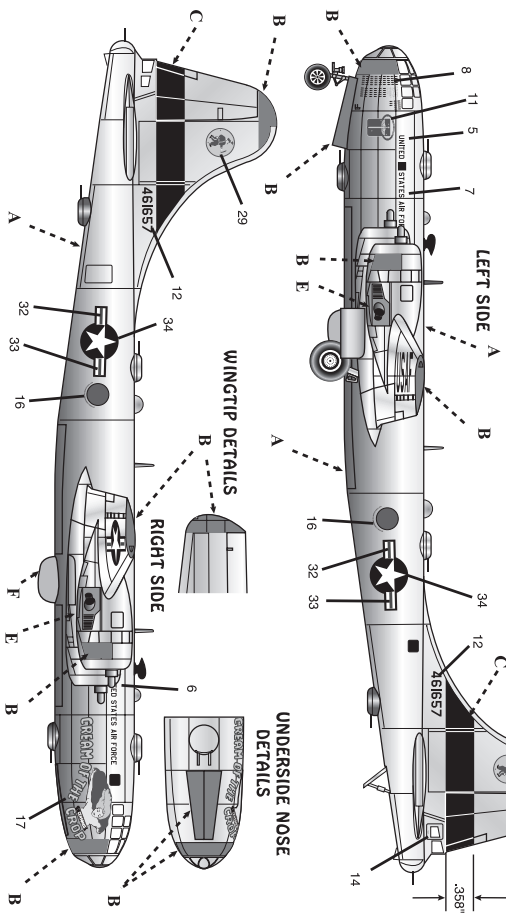

PAINT COLORS	
A	OVERALL NATURAL
B	ALUMINUM
C	BLUE
D	TESTOR 1110
E	BLACK
F	YELLOW
	FS 13538
	STEEL
	LIGHT GRAY
	FS 16492