

German Tank Pz.Kpfw. III ausf. M

1/72



SPECIFICATION

GENERAL

CREW: FIVE—COMMANDER, GUNNER, LOADER, DRIVER, RADIO OPERATOR.

BATTLE WEIGHT: 25,5 tons.

GROUND PRESSURE: 0 99 Kg/cm²

DIMENSIONS

LENGTH OVERALL: 6,550 mm.

HEIGHT: 2,500 mm.

WIDTH: 3,410 mm.

TRACK CENTRES: 360 mm.

GROUND CLEARANCE: 385 mm.

ARMAMENT

ORIGINALLY, ONE 3 7 cm KwK L/45, LATER UP-GUNNED TO 5 cm KwK 39 L/42.

ONE MG 34 7 92 mm, MOUNTED CO-AXIALLY

ONE MG 34 7 92 mm, MOUNTED IN HULL FRONT, RIGHT

FIRE CONTROL

TURRET TRAVERSE, 360°, BY HAND WHEEL, ELEVATION BY HAND 10°, DEPRESSION 10° ELECTRIC PRIMER OPERATED BY TRIGGER. CO-AXIAL MG FIRED BY ROD AND PEDAL FROM GUNNER'S RIGHT FOOT HULL MG FIRED BY TRIGGER.

ENGINE

MAYBACH HL 120 TRM: PETROL

12 CYLINDERS, 60° "V", WATER COOLED

CAPACITY 11867 cc.

PERFORMANCE

MAXIMUM ROAD SPEED: 40 Km/h.

MAXIMUM GRADIENT: 30°

TRENCH CROSSING: 2,300 mm.

WADING DEPTH: 800 mm.

RANGE: ROAD 165 Km/CROSS COUNTRY 95 Km.

FUEL CONSUMPTION: 187 LITRES/100 Km.

KIT 8001

ARMOR

ESCI

MADE IN ITALY

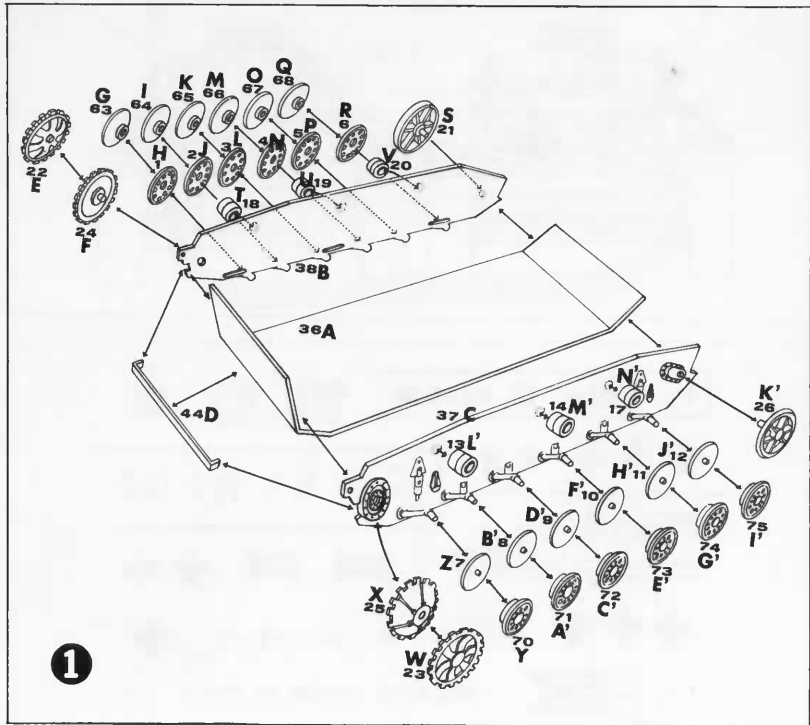
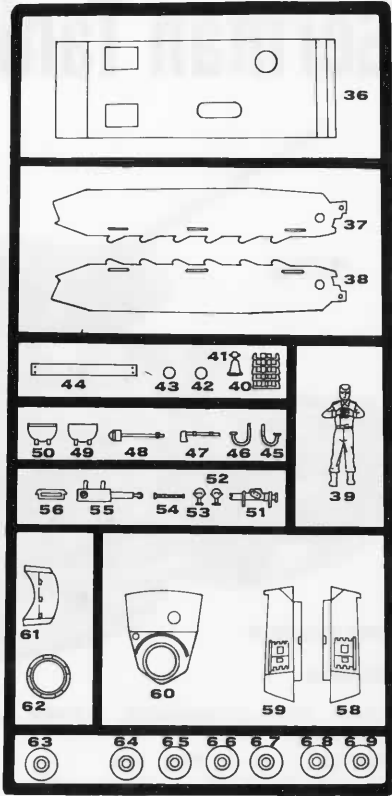
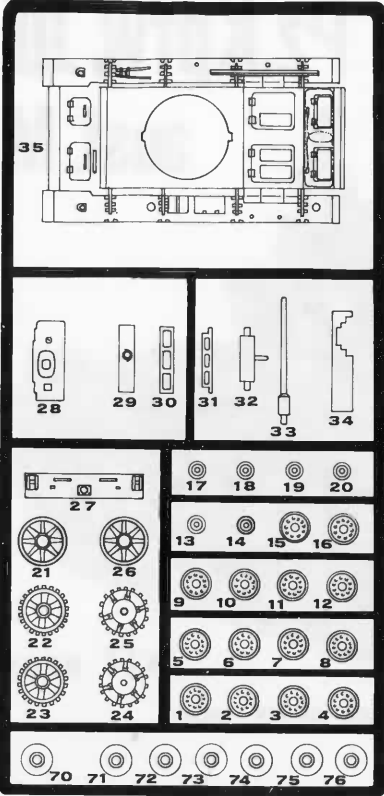

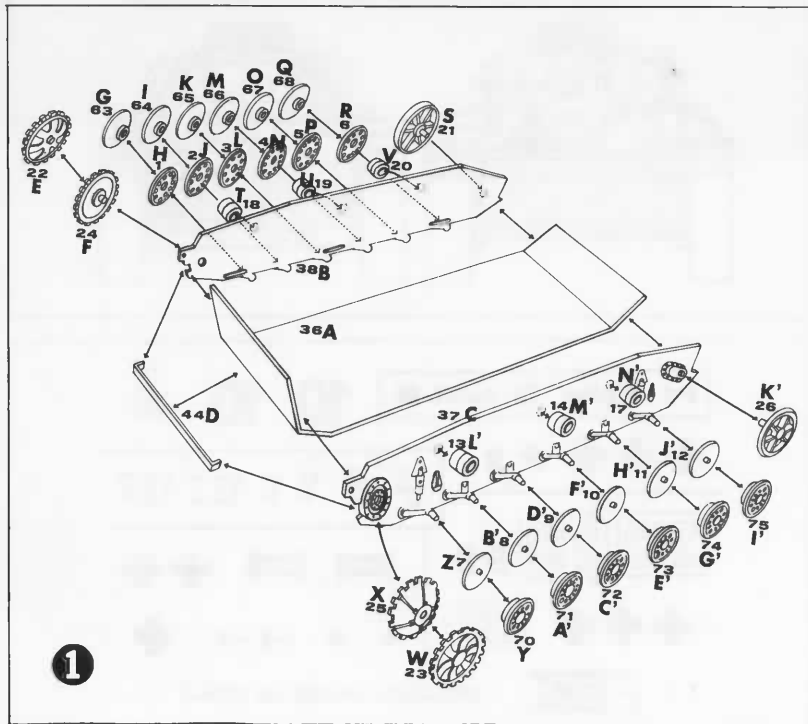
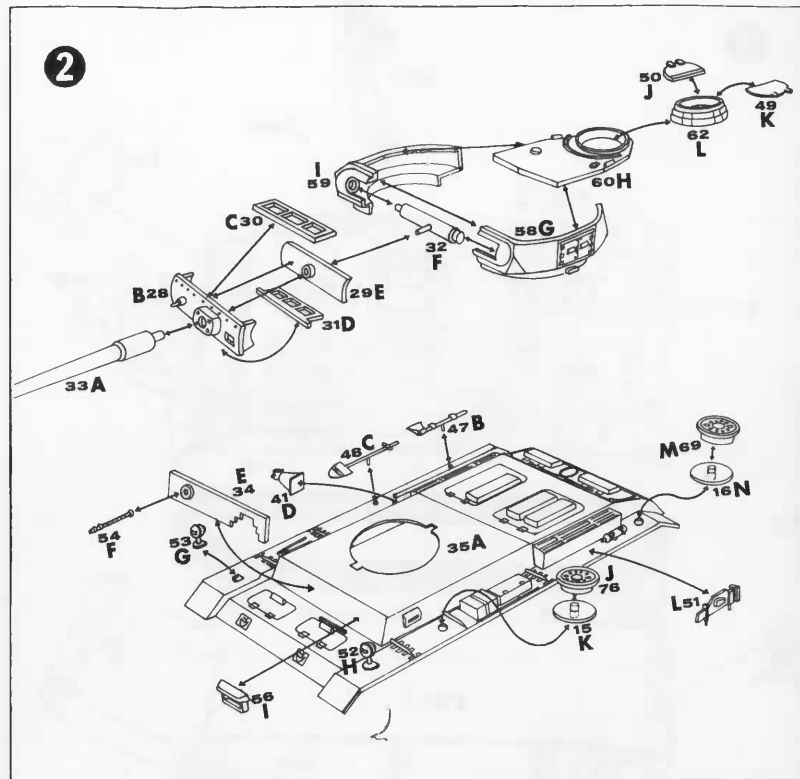

3



G42F



FIG. 2

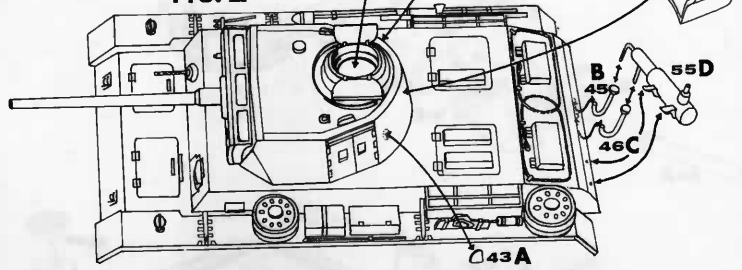

G43A

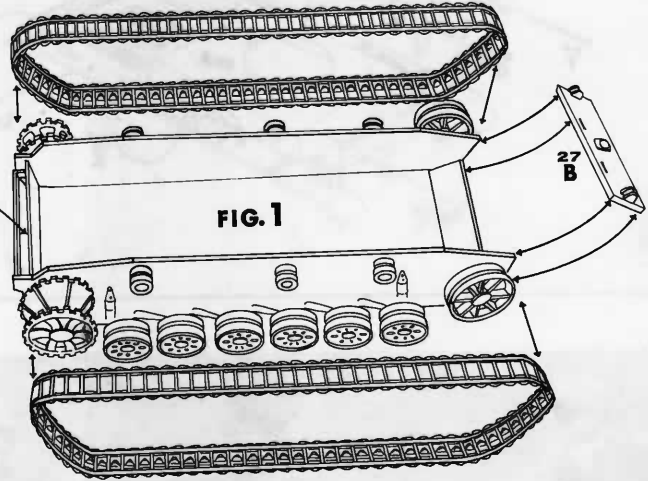
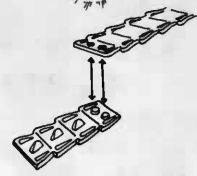
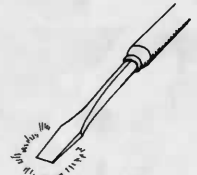

FIG. 1

40A

27 B



39

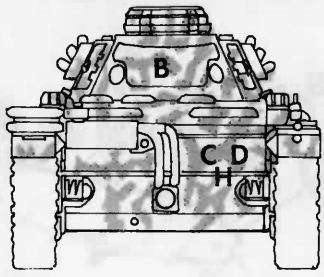
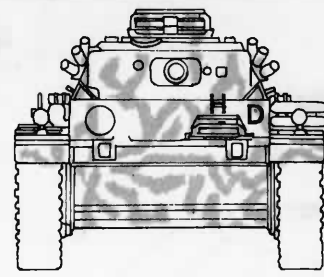
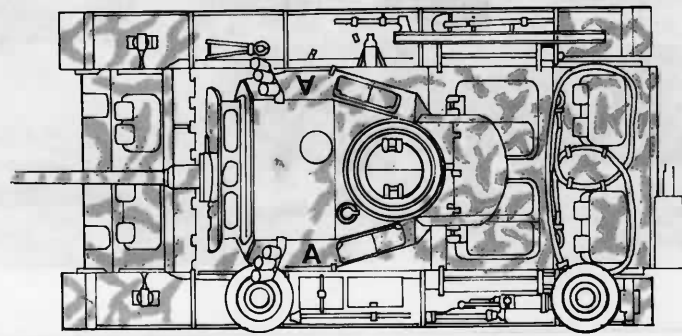
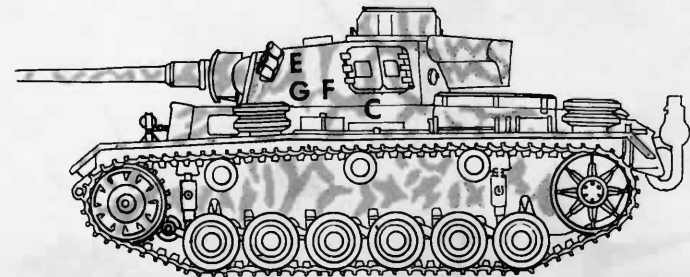

Pz. Kpfw. III ausf. M

10^A 10^B

+++_C XX_D

E D F
Y. Y. 122 122

213^A 213^D DD

— G — ++_C

C +++ 213^B

▲_D ▲ ↔_H ↔ +

E SCK - MILANO - MADE IN ITALY