

部品图 Parts

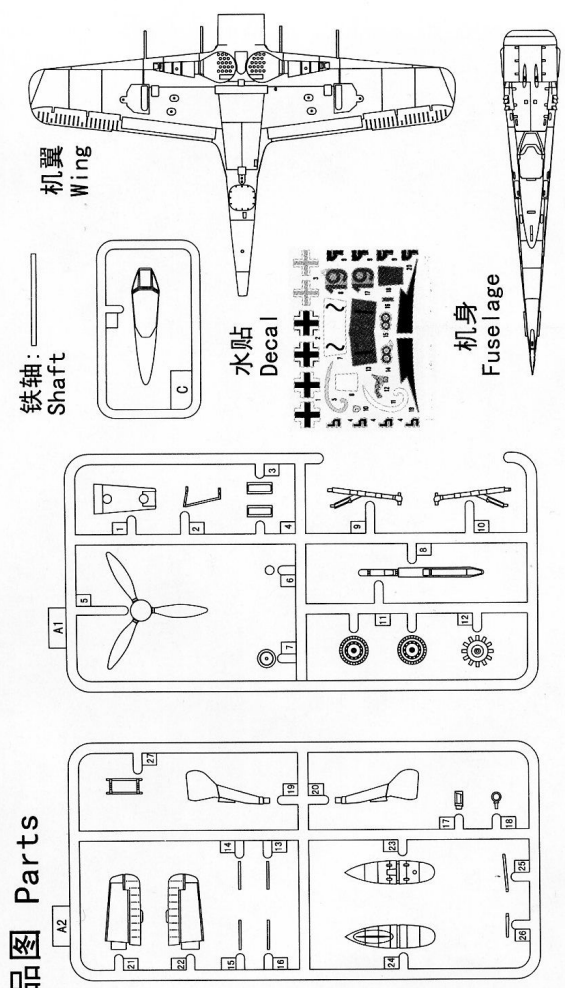

1

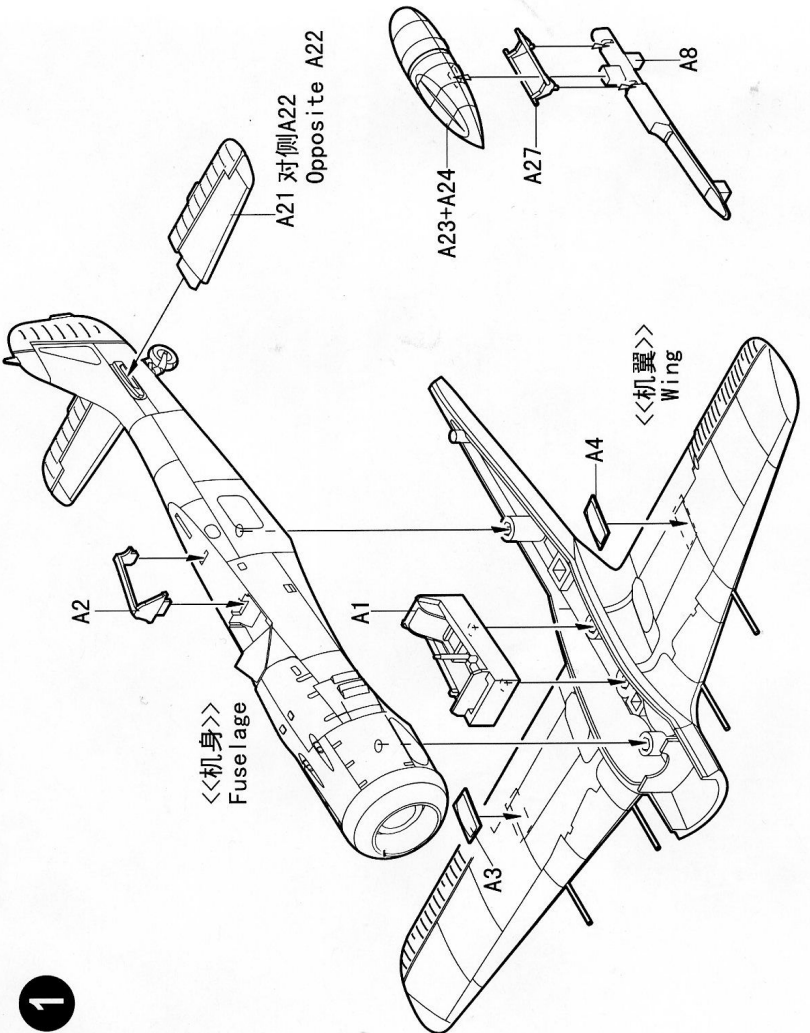

2

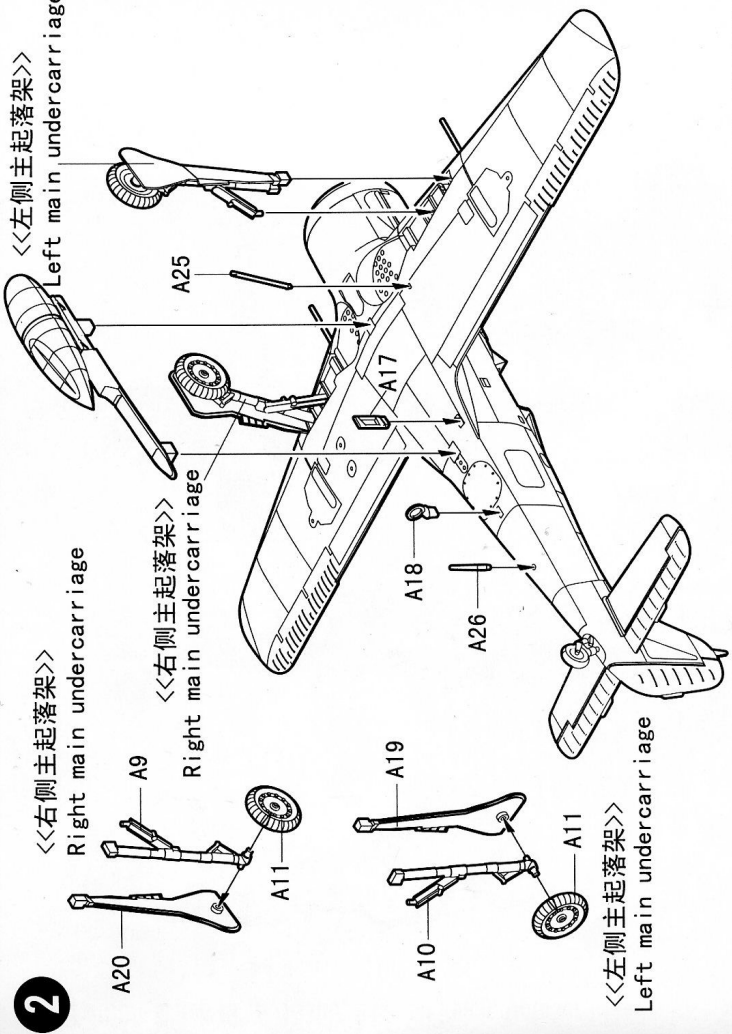

3

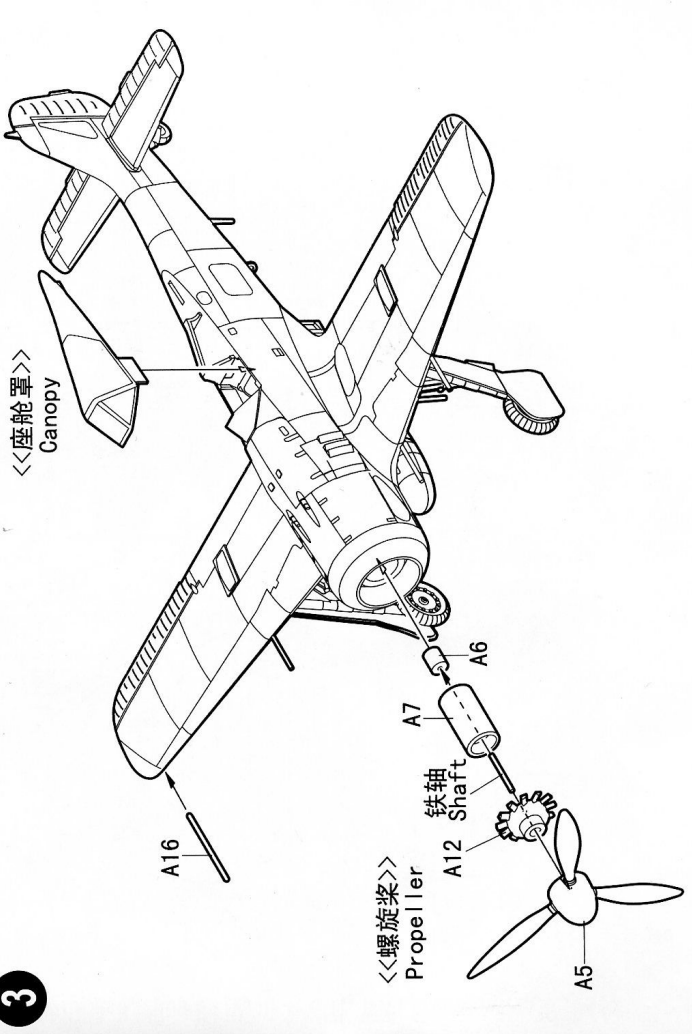

Fw190A-8 "Red 19", 5./JG300, Base on Reich, October 1944.

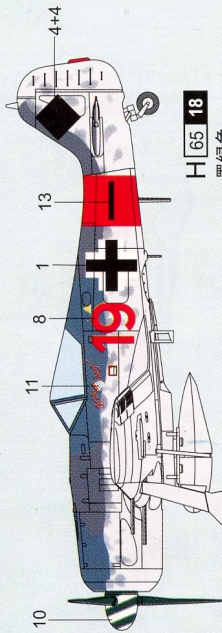

H | 65 | 18  
墨绿色  
RLM70 Black Green

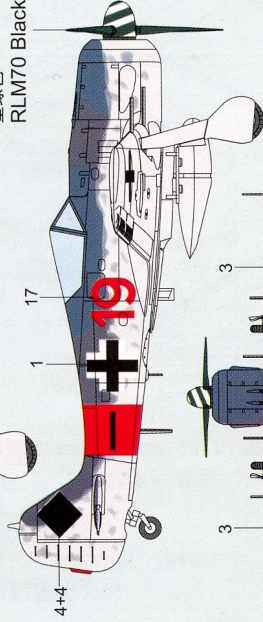

H | 69 | 37  
深绿色  
RLM75 Gray

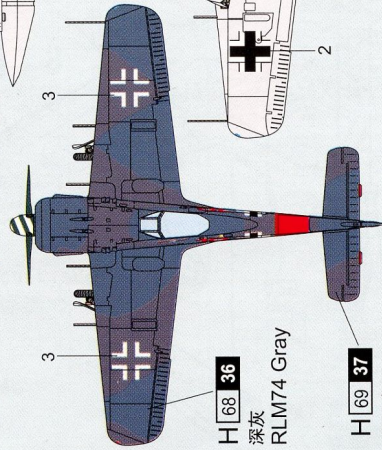

H | 68 | 36  
深灰  
RLM74 Gray

H | 69 | 37  
深绿色  
RLM75 Gray

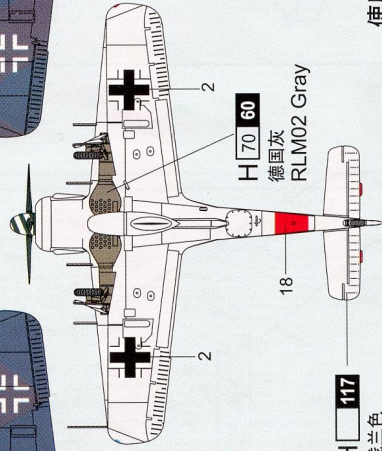

H | 70 | 60  
德国灰  
RLM02 Gray

H | 117 |  
浅兰色  
RLM76 Light Blue

涂装同标贴指示  
Painting & Marking guide

Fw190A-8, "Red 8" IV/JG 3, Uffz. Willi Maximowitz, 06.1944.

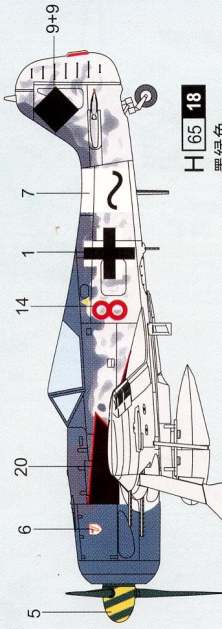

H | 65 | 18  
墨绿色  
RLM70 Black Green

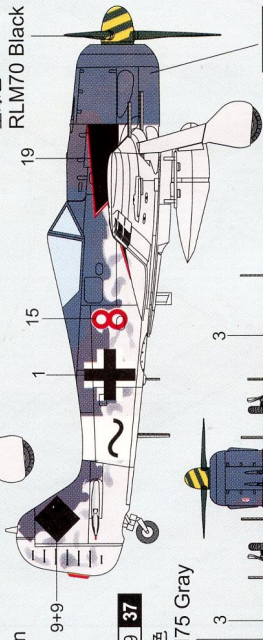

H | 68 | 36  
深灰  
RLM74 Gray

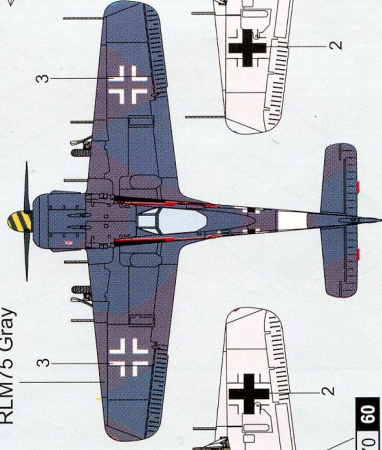

H | 68 | 36  
深灰  
RLM74 Gray

H | 69 | 37  
深绿色  
RLM75 Gray

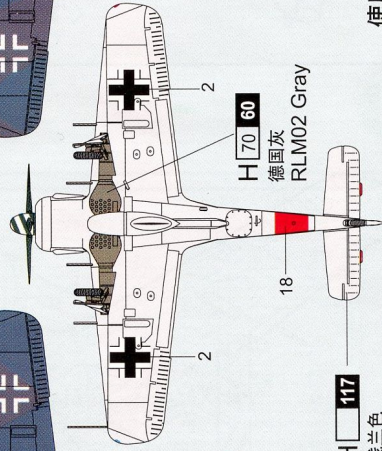

H | 70 | 60  
德国灰  
RLM02 Gray

H | 117 |  
浅兰色  
RLM76 Light Blue

使用Mr.HOBBY涂料  
Mr. Color used

8 AQUEOUS HOBBY COLOUR 8 MR.COLOUR

※Some paints may not be available in your country. Please check your local hobby shop for substitute

# Fw 190A-8



## EASY ASSEMBLY AUTHENTIC KIT



cyanoacrylate glue  
强力胶



weight  
配重



make hole  
钻孔



cut / remove  
切除



option  
选择



no cement  
不涂胶水



decal  
贴纸



bend  
弯曲

### How to apply the decals

1. Cut off the decal from the decal paper and put it into the warm water 40°C for 10 seconds.
2. Take the decal from the water and put it on a piece of clean cloth.
3. Remove the decal slowly from the paper to the targeted location by a wet finger.
4. Use a piece of dry and soft cloth to press it gently on the decal until it getting dry and no bubble existing.

### 水贴纸的使用方法:

- 一. 把相关的印花从水贴上剪下, 放入40°C左右的温水中浸10秒。
- 二. 然后将印花放在干净的布上。
- 三. 拿上印花纸板, 手指蘸水将印花移到适当的位置。
- 四. 用软干布轻压印花直至水干, 气泡消失。