

4736-3800

The second operational space shuttle, the "Challenger", will be launched in the beginning of 1983. NASA plans to utilize all space shuttles, past, present, and future, in rotation, on over 100 flights each.

The one hundred ton plus weight of the space shuttle requires a powerful launching system. When launched the shuttle's engines draw over a half million gallons of fuel from an externally attached giant fuel

tank. An additional 5.8 million pounds of thrust are provided by a pair of solid-fuel boosters attached to the main tank.

These reusable solid-fuel rocket engines, the largest ever flown, are returned to Earth by giant parachute clusters large enough to cover an entire football field. These empty engine shells are then recovered by ships and towed back to the launch site where they are shipped to their builders for refueling.

**ENGLISH:** ASSEMBLY DRAWINGS SHOULD BE REVIEWED BEFORE PROCEEDING WITH CONSTRUCTION. A NUMBER IDENTIFIES EACH PLASTIC PART FOR YOUR CONVENIENCE. PAINT SMALL PARTS ON RUNNER BEFORE REMOVING. ALLOW PAINT TO DRY THOROUGHLY BEFORE CONTINUING ASSEMBLY OF KIT. SCRAPE CHROME OR PAINT AT AREA TO BE GLUED. WASH PLASTIC IN MILD DETERGENT SOLUTION. RINSE AND LET AIR DRY FOR BETTER PAINT AND DECAL ADHESION.

**DEUTSCH:** VOR DEM ZUSAMMENBAU DIE BAUANLEITUNG GUT DURCHLESEN. JEDES TEIL IST NUMMERIERT. KLEINE TEILE ANSTREICHEN BEVOR SIE VOM RAHMEN ENTFERNT WERDEN. FARBEN GUT TROCKNEN, ERST DANN MIT DER ZUSAMMENSTELLUNG FORTSETZEN. CHROM UND FARBE AN DEN KLEBEFLÄCHEN ENTFERNEN. PLASTIKTEILE IN EINER MILDEN WASCHMITTELLOESUNG REINIGEN UND AN DER LUFT TROCKNEN, DAMIT FARBE UND ABZIEHBILDER BESSER HAFTEN.

**FRANCAIS:** EXAMINER LES SCHEMAS D'ASSEMBLAGE AVANT DE COMMENCER LA CONSTRUCTION. UN NUMERO IDENTIFIE CHAQUE PIECE DE PLASTIQUE POUR PLUS DE FACILITE. PEINDRE LES PETITES PEICES SUR LE SUPPORT AVANT DE LES ENLEVER. LAISSER LA PEINTURE SECHER COMPLETEMENT AVANT DE CONTINUER L'ASSEMBLAGE DU KIT. GRATTER LE CHROME OU LA PEINTURE SUR LES SURFACE A COLLER. LAVER LE PLASTIQUE DANS UNE SOLUTION DE DETERGENT LEGERE, RINCER ET LAISSER SECHER A L'AIR POUR UNE MEILLEURE ADHERENCE DE LA PEINTURE ET DES DECALS.

**NEDERLANDS:** BESTUDEER DE MONTAGE TEKENINGEN, VOORDAT U MET BOUWEN BEGINT. VOOR UW GEMAK, IDENTIFICEERT EEN NUMMER ELK PLASTIC DEEL. VERF KLEINE DEELTJES OP KIBOOM VOORDAT U ZE VERWYDERD. LAAT VERF GRONDIG DROGEN VOORDAT U DE MONTAGE VAN HET MODEL VOORTZET. SCHRAP CHROOM OF VERF VAN HET GEDEELTE DAT GELYMD WORDT. WAS PLASTIC MET EEN ZACHTE ZEEP, SPOEL AF, EN LAAT IN LUCHT DROGEN, ZODAT VERF EN DECAL BETER PLAKKEN.

**SVENSKA:** IHOPSÄTTNINGSSKISSEN BÖR GRANSKAS INNAN IGÅNGSÄTTANDE AV BYGGANDET. ETT NUMMER IDENTIFIKERAS VARJE PLASTDEL FÖR DIN EGEN BEKVÄMLIGH ET. MALA DE SMA BITARNA DIREKT PÅ FARAN INNAN DE TAS BORT. LAT FÄRGEN TORKA GRUNDLIGT INNAN FORTSÄTT BYGGANDE. SKRAPA AV KROMEN ELLER MALA PÅ DELARNA SOM SKÅLL KLISTRAS. TVÄTTA PLASTEN I MILD TVÄTTMEDELLOSNING, SKOIJ OCH LUFTTORKA FÖR BÄTTRE FASTANDE AV FÄRG OCH DEKALER.

**ESPAÑOL:** DIBUJOS DE ENSAMBLAJE DEBEN SER REPASADOS ANTES DE SEGUIR CON LA CONSTRUCCION. UN NUMERO IDENTIFICA CADA PARTE DEL PLASTICO PARA SU CONVENIENCIA. PINTÉ PARTES PEQUEÑAS DEL KIT ANTES DE QUITARLAS. DEJE SECAR BIEN LA PINTURA ANTES DE SEGUIR EL ENSAMBLAJE. RASPE EL CROMO O LA PINTURA DEL SITIO ANTES DE SER PEGADO. LAVE EL PLASTICO EN UNA SOLUCION SUAVE DETERGENTE, ENJUAGUE, Y DEJE SECAR EN EL AIRE PARA MEJOR ADHESION DE LA PINTURA Y CALCOMANIA.

**ITALIANO:** I DISEGNI DELL'ASSEMBLAGGIO DOVREBBERO ESSERE RICONTROLLATI PRIMA DI INIZIARE IL MONTAGGIO. OGNI PEZZO E IDENTIFICATO DA UN NUMERO PER VOSTRA MAGGIORE COMODITA. VERNICIARE LE PARTI PICCOLE SULLA GUIDA DE SCORRIMENTO PRIMA DE TOGLIERLE. LASCIAR ASCIUGARE LA VERNICE PRIMA DI CONTINUARE IL MONTAGGIO. RASCHIAR LA PITTURA O IL CROMO DALLE PARTI CHE DEVONO ESSERE INCOLLATE. LAVARE I PEZZI DI PLASTICA CON UN DETERGENTE NON TROPPO FORTE, SCIACQUARE E LASCIAR ASCIUGARE AFFINCHÉ VERNICE E DECALCOMANIE ADERISCANO MEGLIO.



GLUE  
KLEBER  
COLLE  
LIJM  
KLISTER  
PEGA  
COLLA



NO GLUE REQUIRED  
KEIN KLEBER NOTWENDIG  
LA COLLE N'EST PAS NECESSAIRE  
GEEN LIJM NODIG  
INGET KLISTER BEHOVS  
NO NECESITA PEGA  
NON C'E BISOGNO DI COLLA



DO IT THIS MANY TIMES  
ANZAHL DER ARBEITSGÄNGE  
LE FAIRE CE NOMBRE DE FOIS  
DOE HET ZOVEEL KEER  
GJOR DET SA MANGA GÄNGER  
FATELO TUTTE QUESTA VOLTE  
HAGALO ESTA CANTIDAD DE VECES



OPTIONAL  
WAHLWEISE  
FACULTATIF  
NAAR KEUZE  
VALFRI  
FACOLTATIVO  
OPCIONAL



APPLY DECALS  
ABZIEHBILDER ANBRINGEN  
COLLER LES DECALCOMANIES  
BRENG PLAKPLAATJES AAN  
SATT PÅ DEKALERNA  
APPLICARE LE DECALOMANIE (ADESIVI)  
APLICAR CALCAS



SHOWN ASSEMBLED  
ABBILDUNG DES ZUSAMMEN GEBAUTEN MODELLS  
VU ASSEMBLE  
GEMONTEERD GETOOND  
VISAD IHOPSÄTTNING  
MOSTRADO ARMADO  
ILLUSTRAZIONE DEL PEZZO MONTATO



CLEAR  
KLAR  
TRANSPARENT  
DOORZICHTIG  
KLART  
VIA LEBERA  
TRANSPARENT



WHITE  
WEISS  
BLANC  
WIT  
VIT  
BLANCO  
BIANCO



<b>A</b>	GRAY METALLIC	GRAU METALLISCH	GRIS METALLISE	METAAL-GRIJS	GRAMETALLIK	GRIS METALICO	GRIGIO METALLIZZATO
<b>B</b>	TAN	BEIGE	BRUN	TAANKLEUR	BEIGE	MORENO	MARRONE BRUCIATO
<b>C</b>	MATT DARK OCHRE	MATT DUNKELOCKER	OCREUX FONCE MAT	MAT DONKEROKER	MATT MORKOCKRA	OCRE OSCURO MATE	OCRA SCURO SMORTO
<b>D</b>	BLACK	SCHWARZ	NOIR	ZWART	SVART	NEGRO	NERO
<b>E</b>	IVORY	ELFENBEIN	IVOIRE	IVOOR	ELFENBEN	MARFIL	AVORIO
<b>F</b>	SILVER	SILBER	ARGENT	ZILVER	SILVER	PLATA	ARGENTO
<b>G</b>	MATT MEDIUM GREY	MATT MITTELGRAU	GRIS MOYEN MAT	MAT MIDDELGRUIS	MATT MELLANGRA	GRIS MEDIANO MATE	GRIGIO MEDIO SMORTO

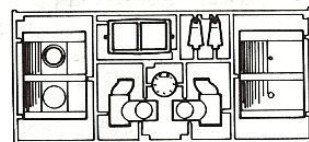
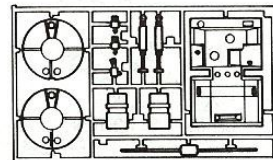
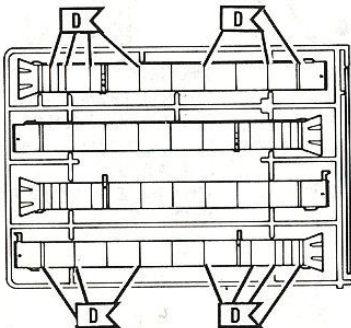
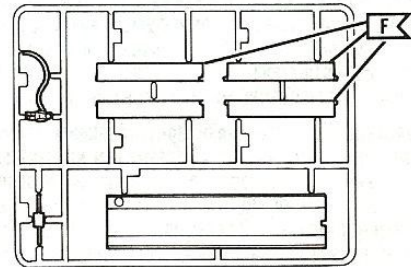
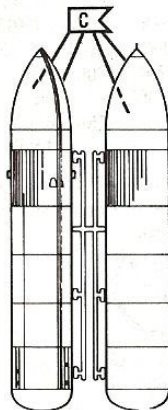
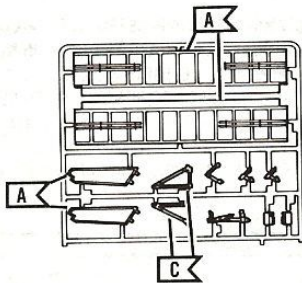
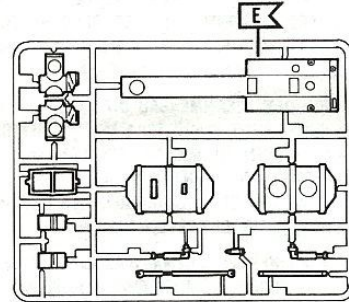
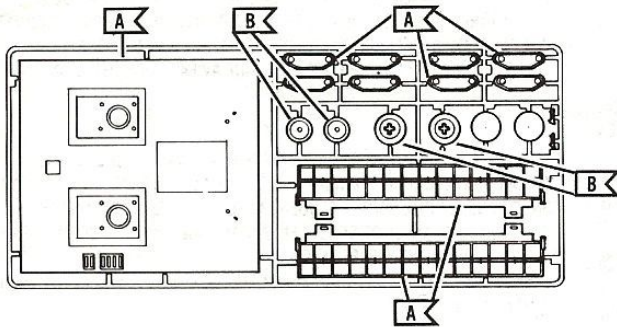
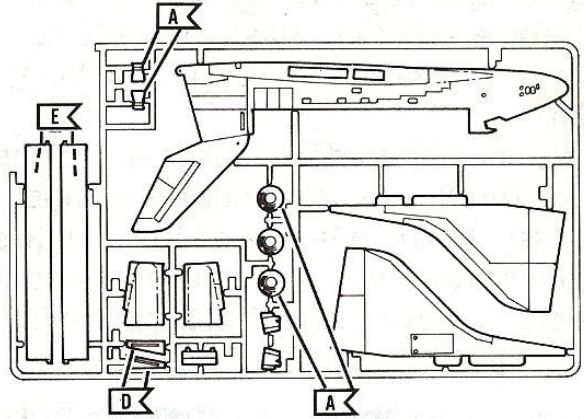
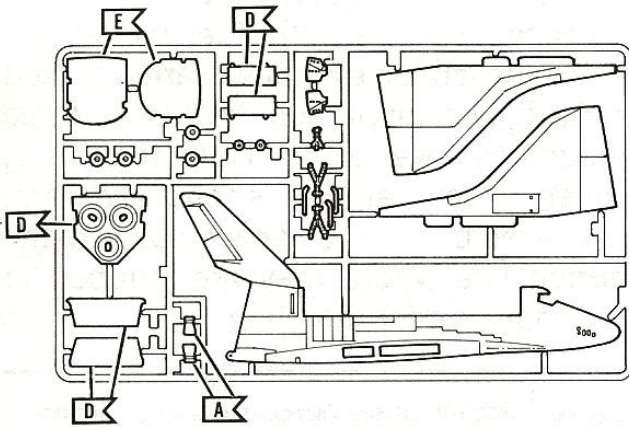



**1**

**(2X)**

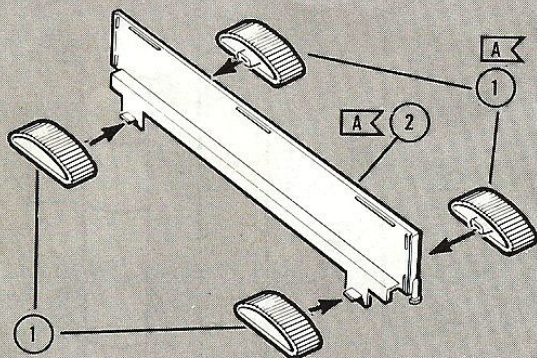

**2**

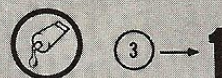
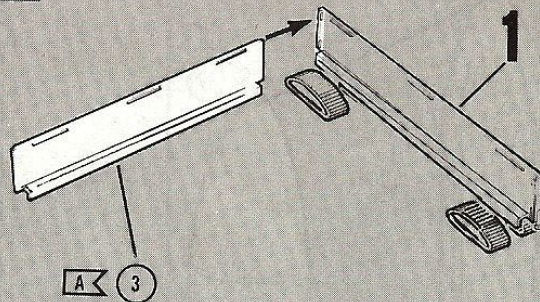

**3**

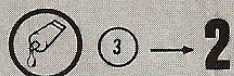
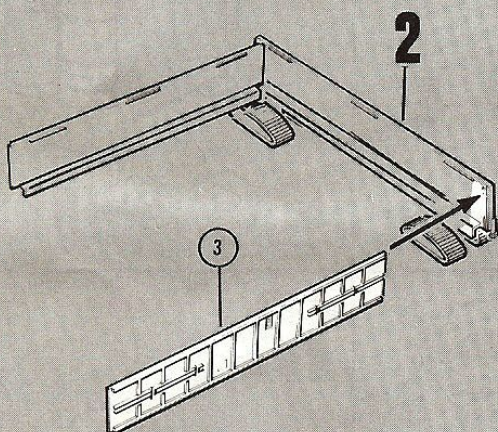

**4**

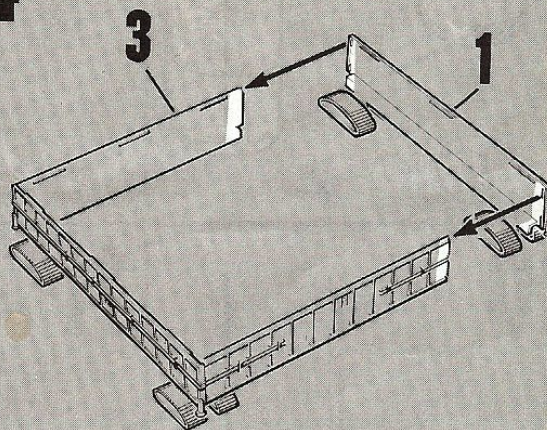

**5**

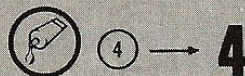
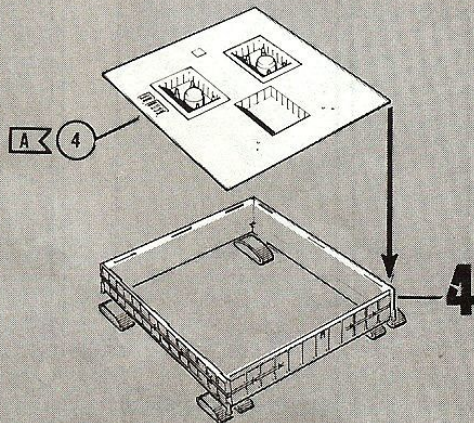

**6**

**(2X)**

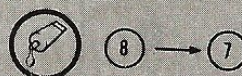
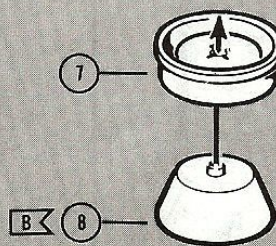



7

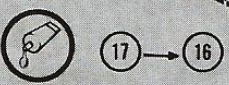
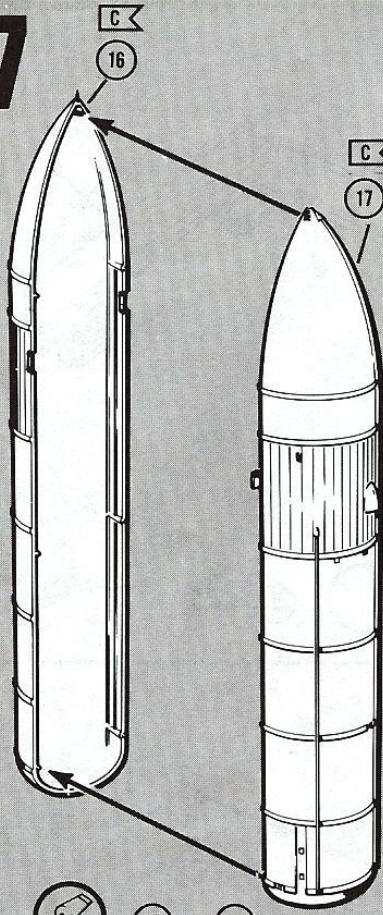

8

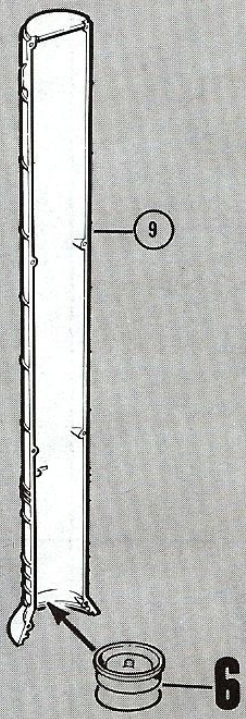

9

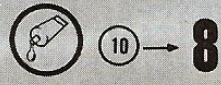
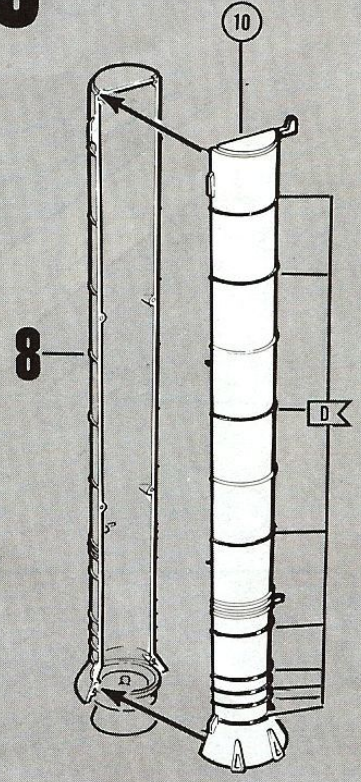

10

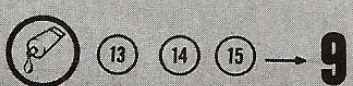
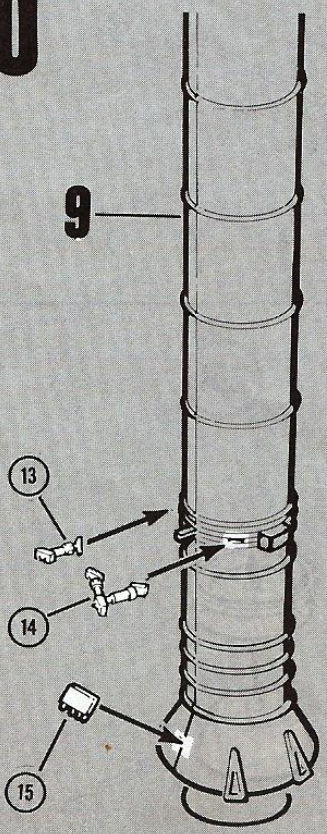

11

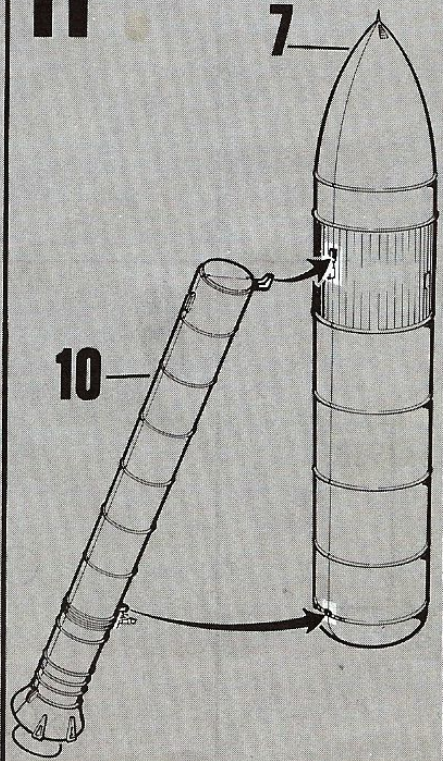

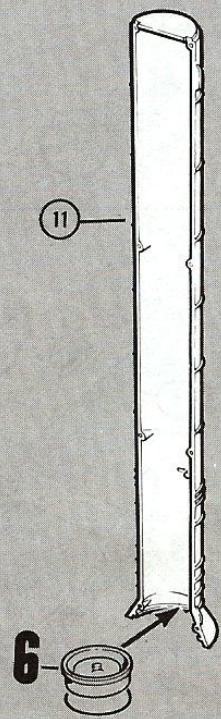

12



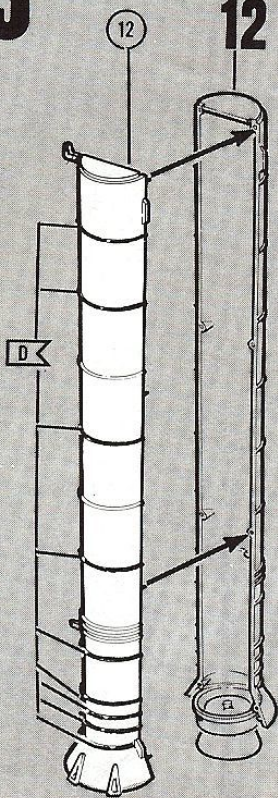

# 13



 12 → 12

# 14

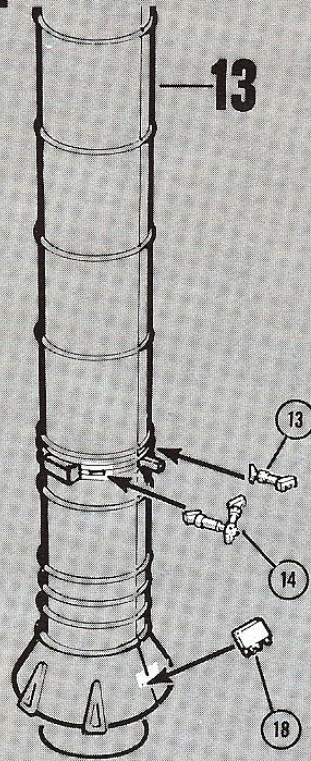

 13 14 18 → 13

# 15

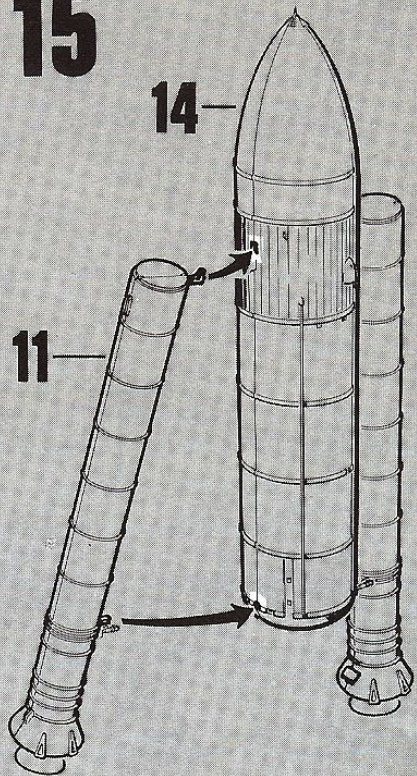

 11 → 14

# 16

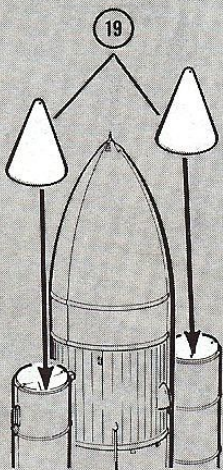

 2X 19 → 15

# 17

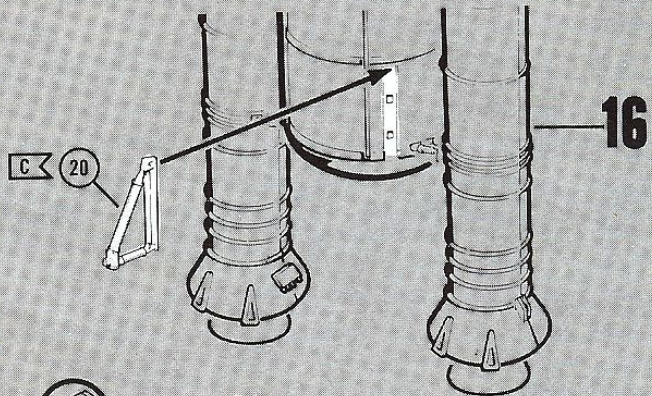

 20 → 16

# 18

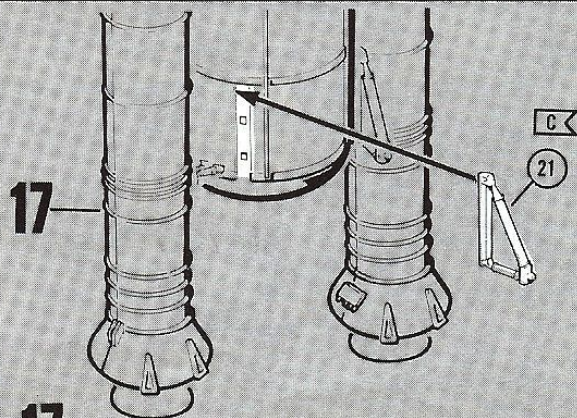

 21 → 17



# 19

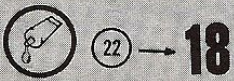
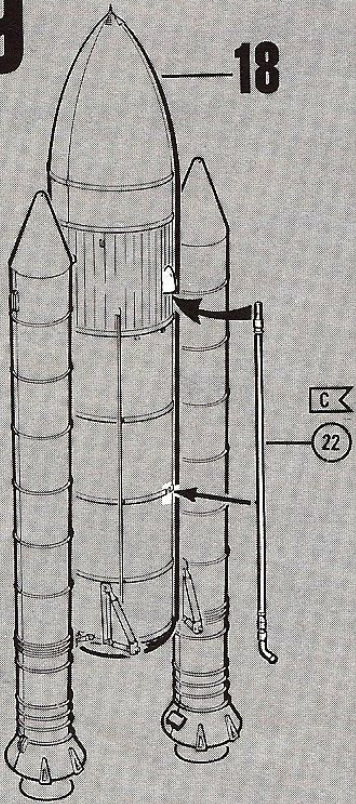

# 20

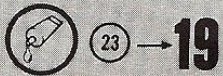
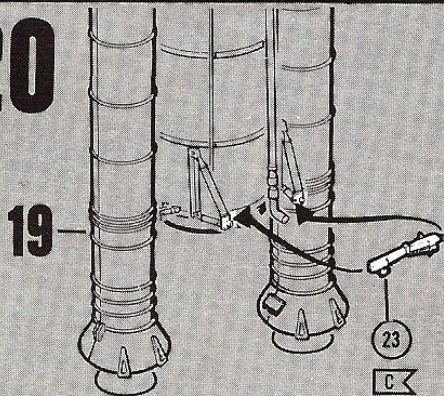

# 21

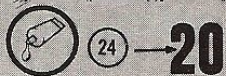
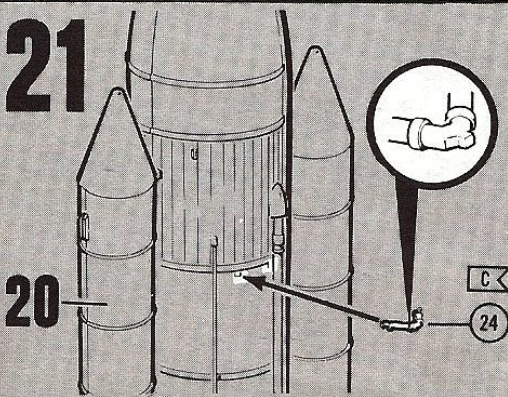

# 22

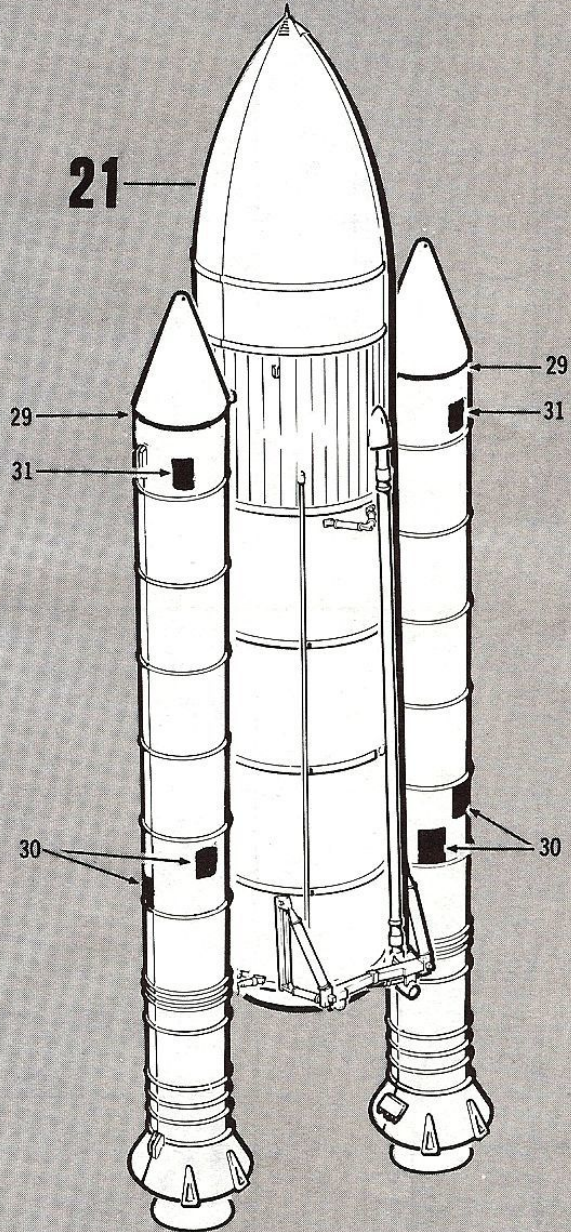
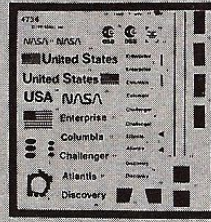

29 30 31 → **21**



# 23

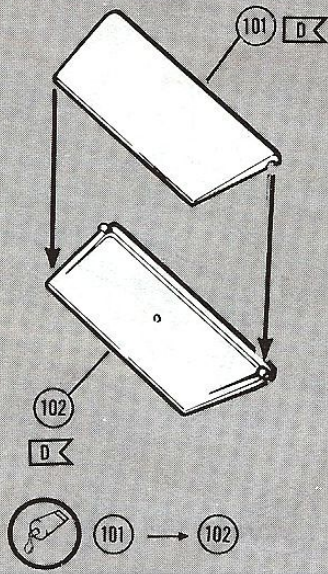

# 24

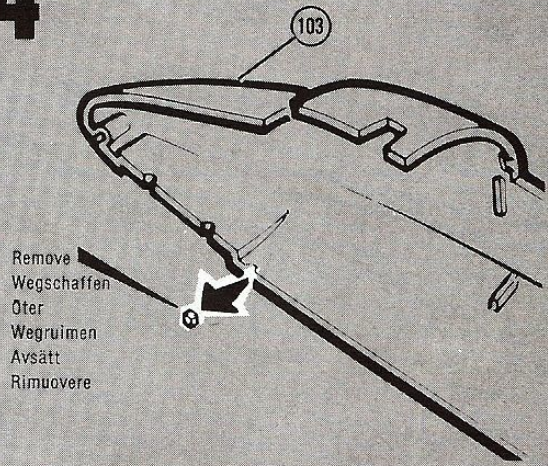

# 25

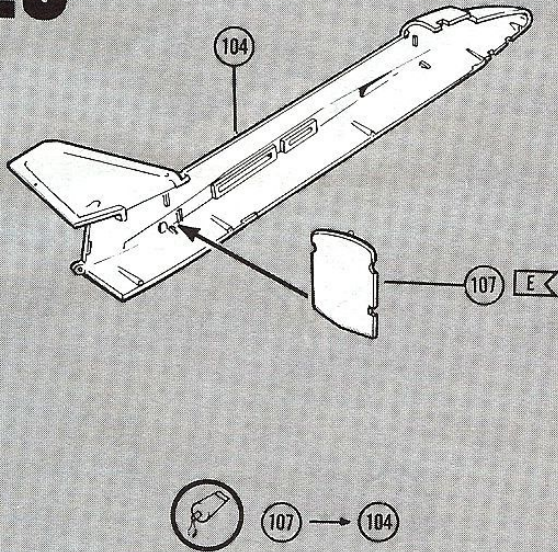

# 26

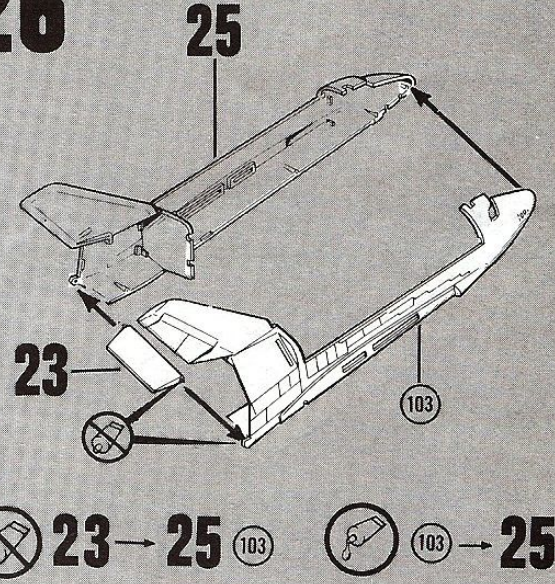

# 27

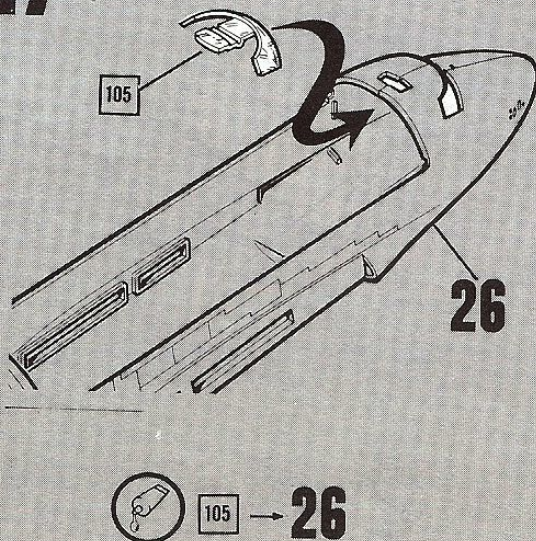

# 28

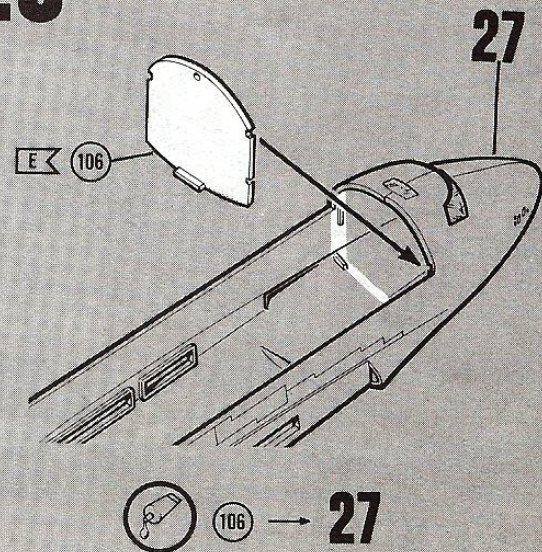



# 29

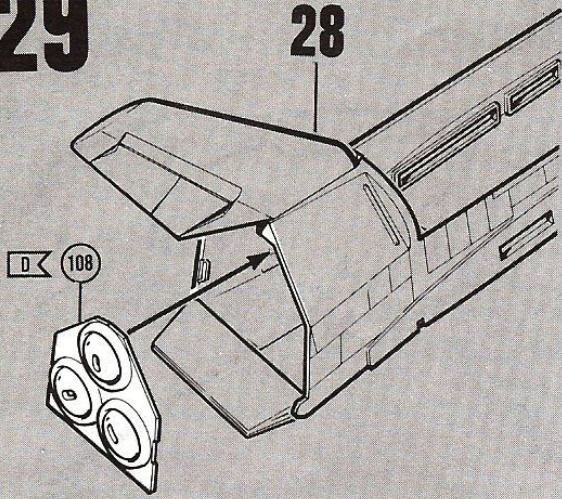

108 → 28

# 30

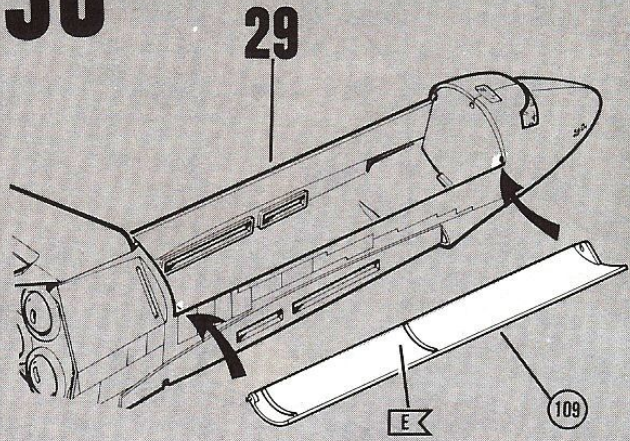

109 → 29

# 31

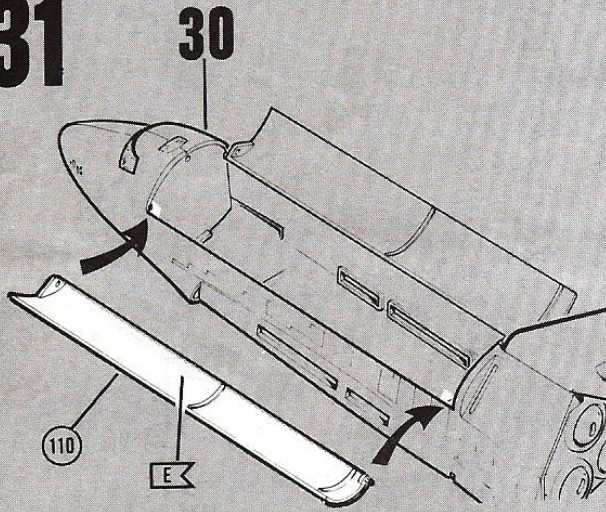

110 → 30

# 32

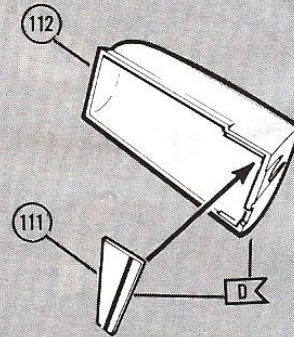

111 → 112

# 33

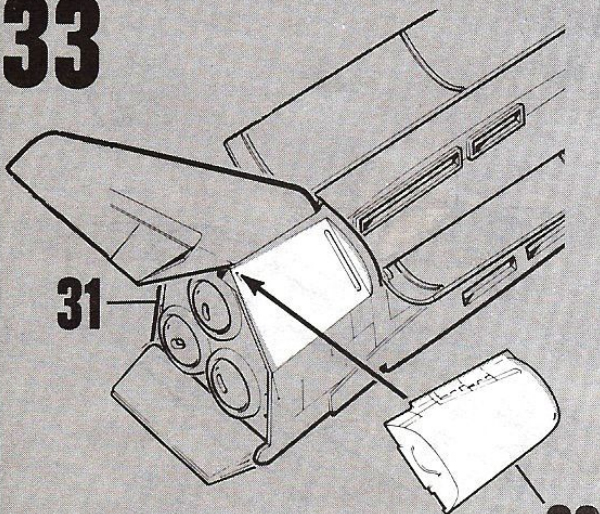

32 → 31

# 34

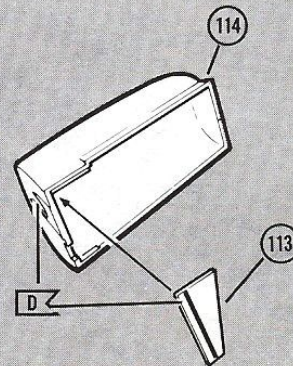

113 → 114



**35**

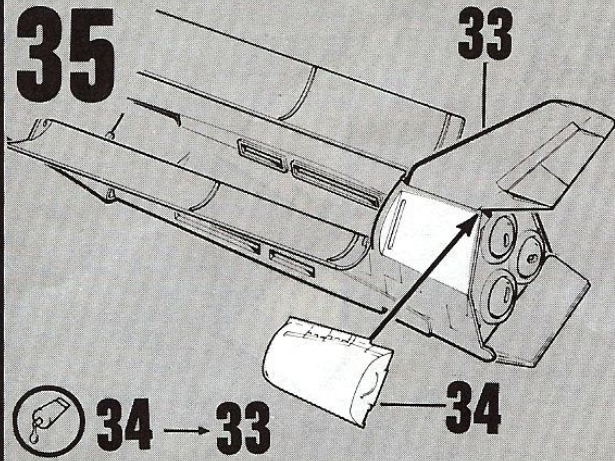

**36**

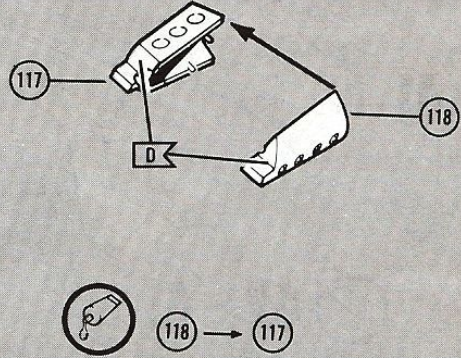

**37**

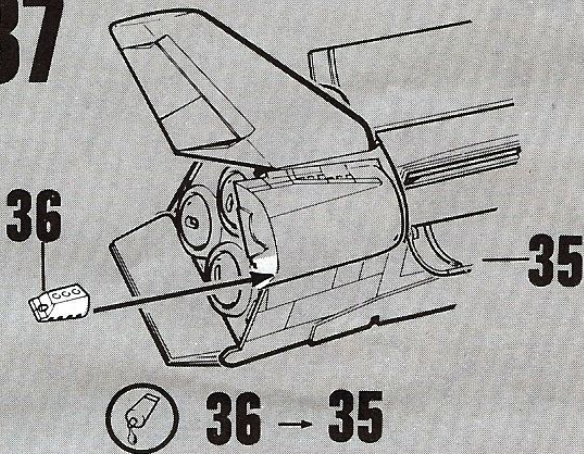

**38**

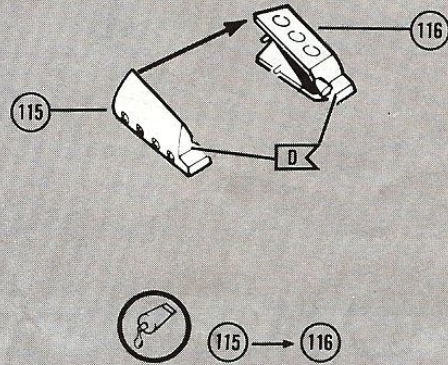

**39**

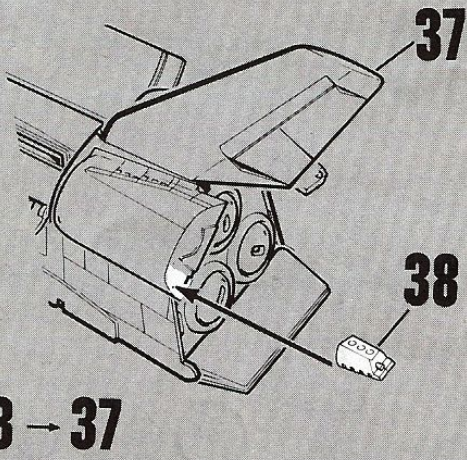

**40**

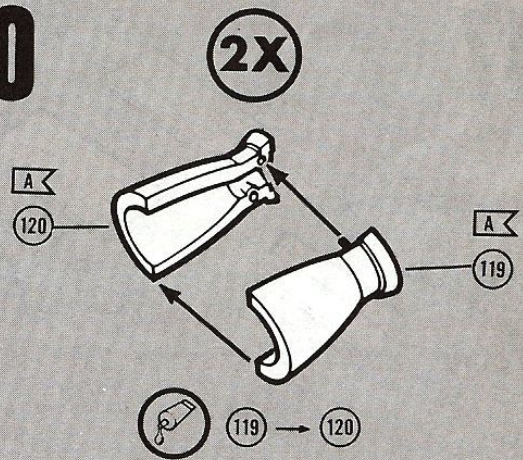

**41**

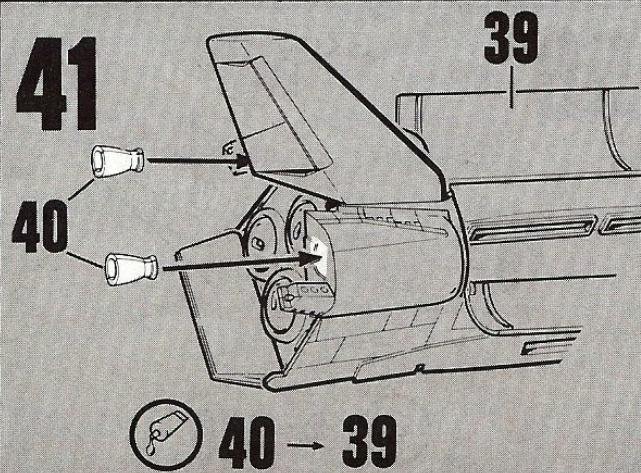

**42**

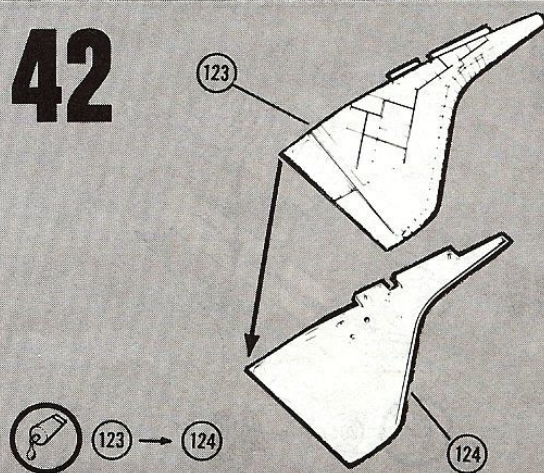



**43**

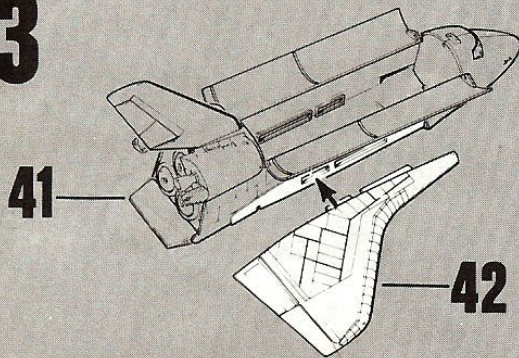

**42** → **41**

**44**

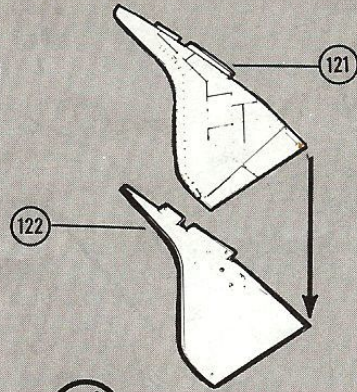

**121** → **122**

**45**

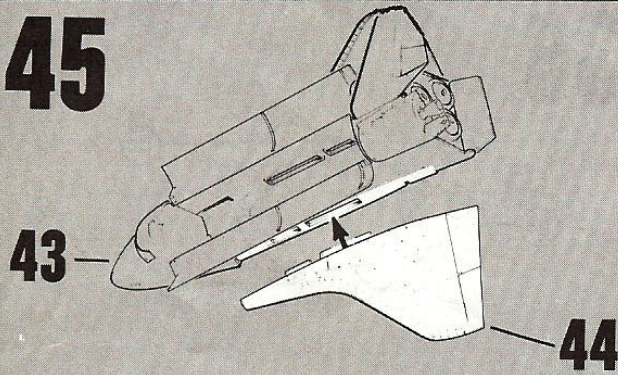

**44** → **43**

**46**

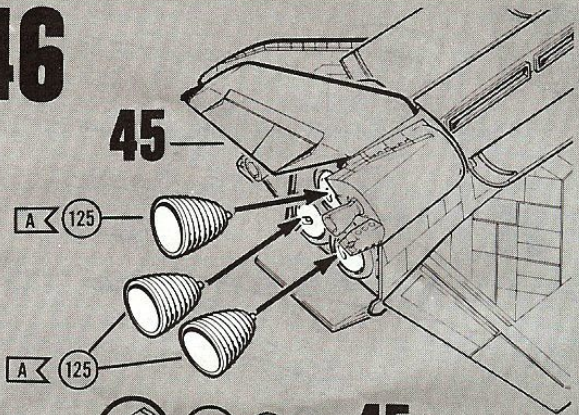

**3X** **125** → **45**

**47**

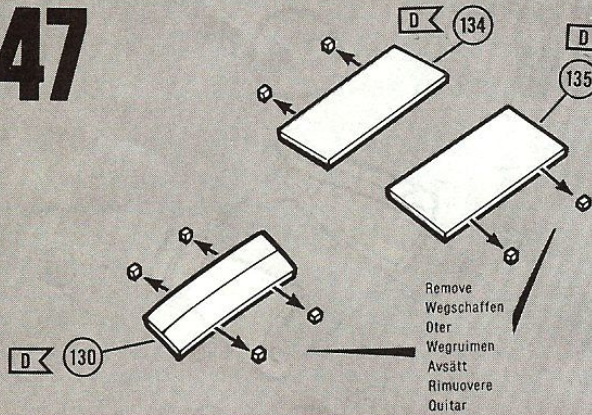

Remove  
Wegschaffen  
Oter  
Wegruimen  
Avsätt  
Rimuovere  
Ouitar

**48**

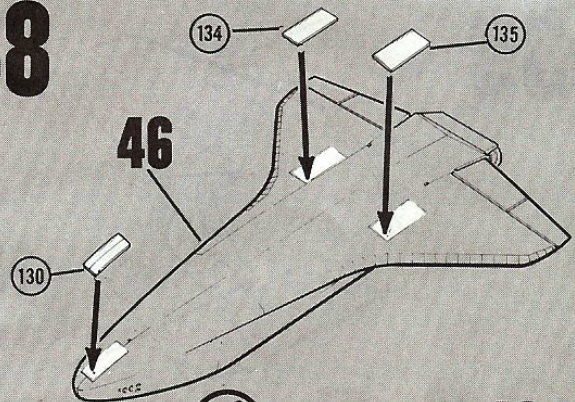

**130** **134** **135** → **46**

**49**

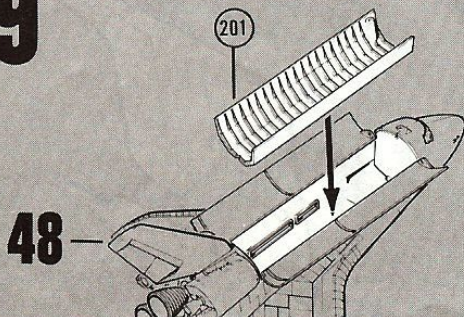

**201** → **48**

**50**

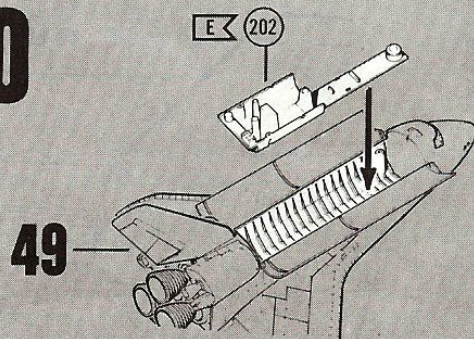

**202** → **49**



# 51

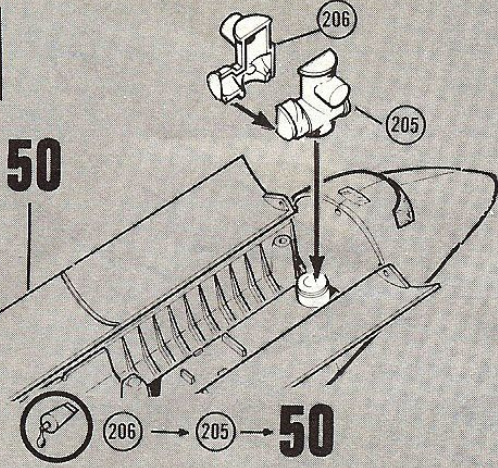

# 52

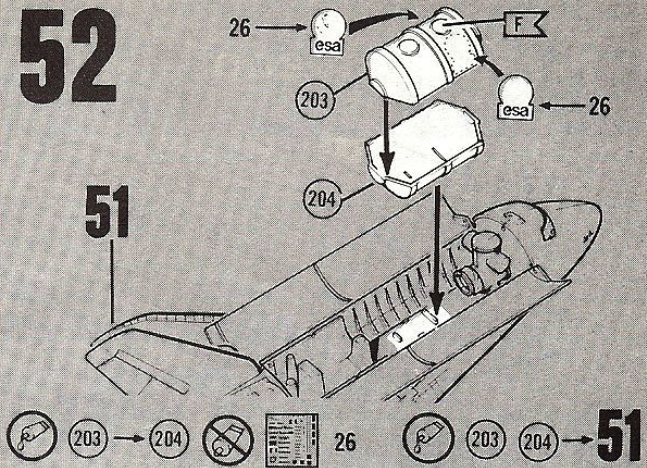

# 53

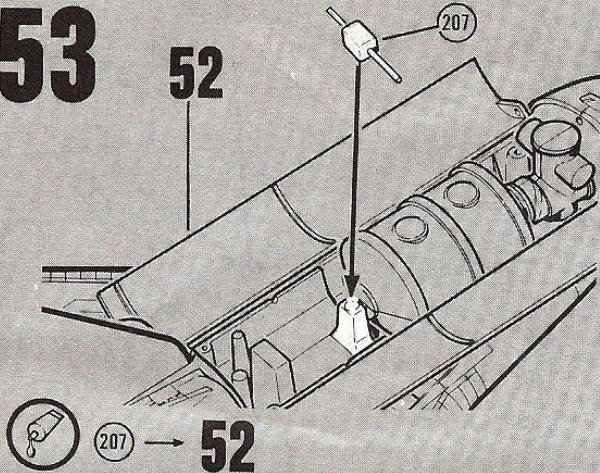

# 54

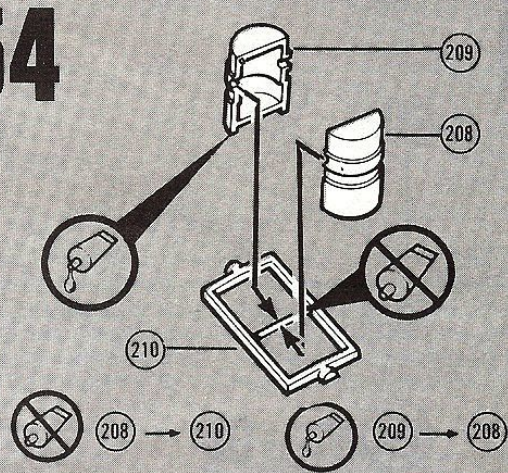

# 55

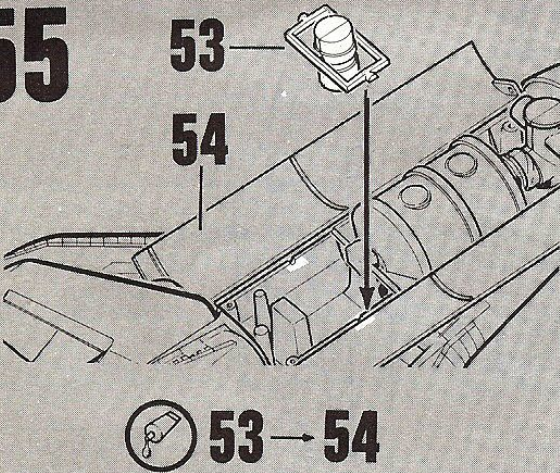

# 56

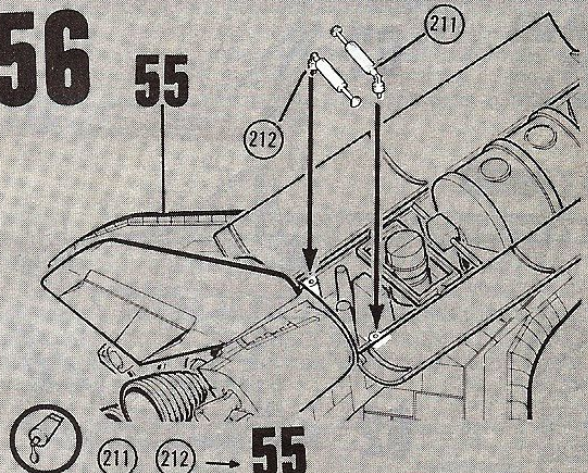

# 57

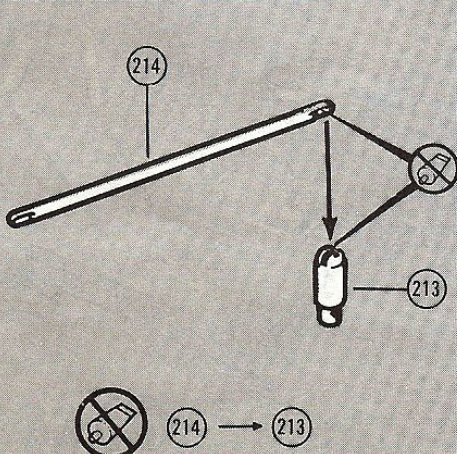

# 58

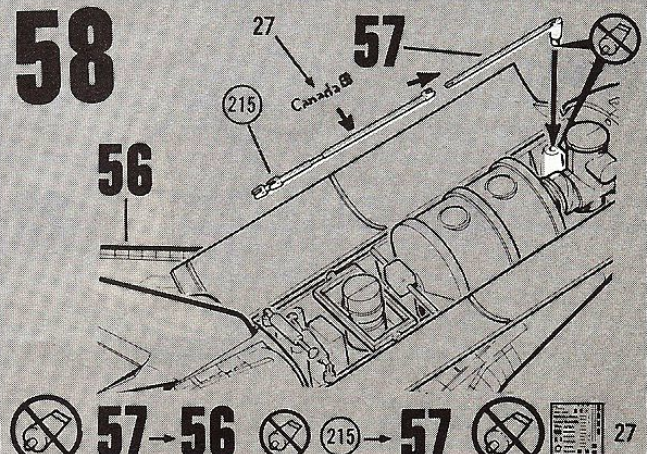



# 59

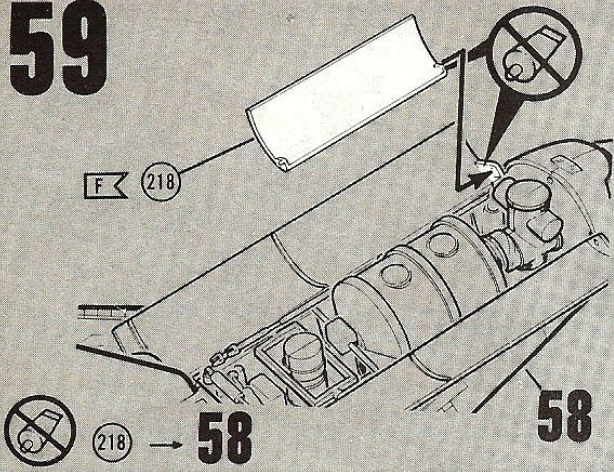

# 60

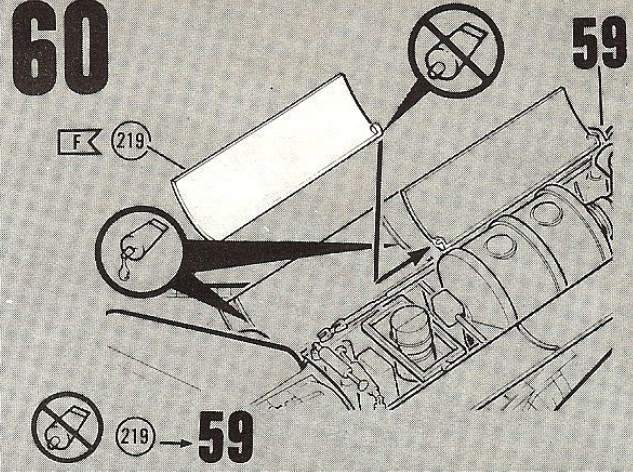

# 61

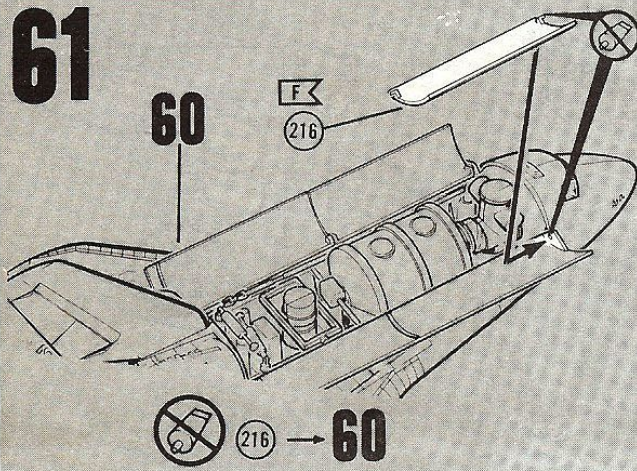

# 62

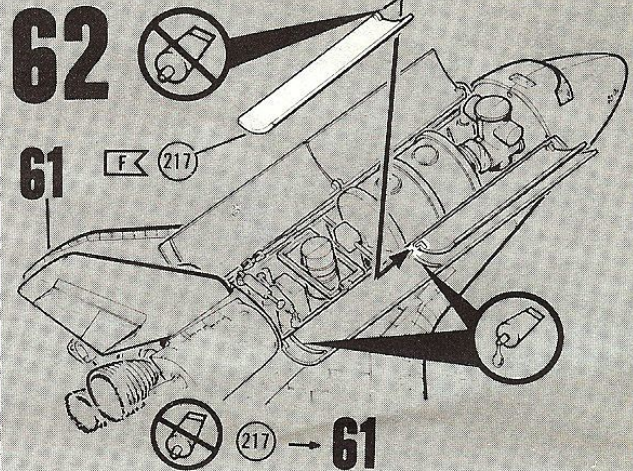

# 63

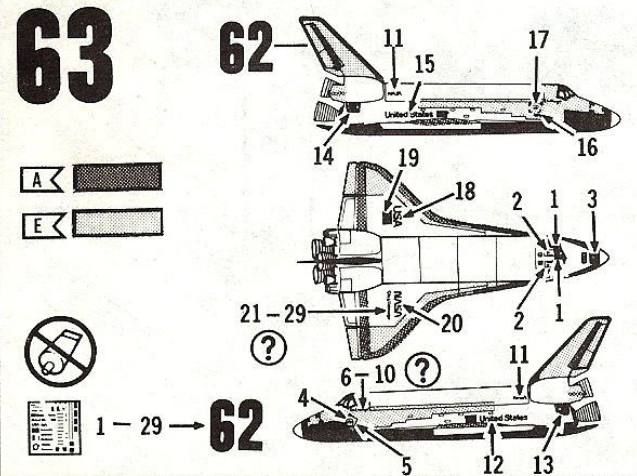

# 65

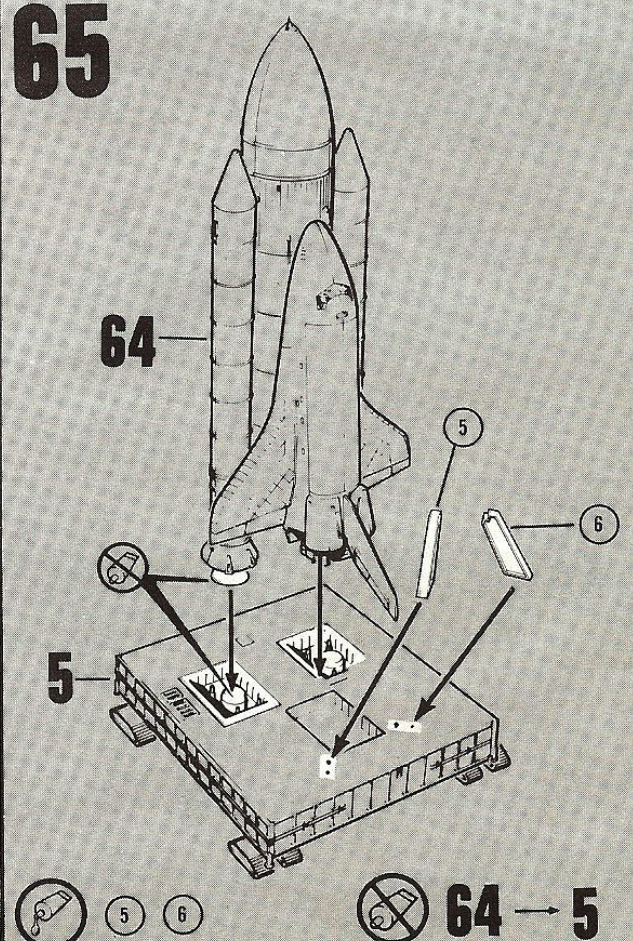

# 64

