

FREEDOM FIGHTER

F-5A

F-5A/CF-5A/NF-5A フリーダムファイター



1/48 F-5A/ CF-5A/ NF-5A

The F-5A Freedom Fighter is a lightweight and low-cost sophisticated aircraft intended for air-to-ground operations. It was originally designed in the 1950s as a potential jet fighter to operate from the US Navy's Escort Carriers but eventually served the U.S. Cold War allies after the Navy's withdrawal of the Carrier.

The Freedom Fighter first flew in 1959 and entered service in the 1960s. Standard armament includes 2 M39 20mm cannons with additional pods or missiles of up to 6200lbs on 5 hardpoints and 2 wingtips. While the F-5A was an aircraft with basic equipment, it has reached across the world to countries including Iran, South Korea, the Philippines, Turkey, Greece and Taiwan through the U.S. Military Assistance Program (MAP) as an ideal solution for an inexpensive, easily maintained but Mach 1.4-capable combat fighter.

Among the F-5A's foreign operators, Canada has made direct purchases and received license to produce the aircraft locally. The Canadian F-5A, designated CF-5A (officially CF-116), has an in-flight refueling probe and was powered by Orenda J85-CAN0-15 series engines. The CF-5A was also sold to the Royal Netherlands Air Force and was designated as NF-5A.

レーダーを持たず目視のみで戦を行う限定されたものであったにも関わらず、優れた空対空戦能力を有し、対地攻撃機能も兼ね備えた F-5A フリーダムファイターは、低コストで運用可能な小型軽量の高性能戦闘機でした。当初、アメリカ海軍 護衛空母での運用の可能性も 踏まえたジェット戦闘機として 1950年代に設計されましたが、全ての護衛空母が退役した結果、軍事援助計画 (MAP) を通じて、冷戦下のアメリカを中心とする西側同盟諸国の防衛に貢献しました。1959年初飛行に成功し1960年代より導入が進められたフリーダムファイターは、両翼端および胴体・両翼下面の5つのパイロンに、ミサイルや爆弾など6,200ポンド (2,812キロ) にも及ぶ追加兵装が搭載可能で、機首には M-39 20mm機関砲 2門が固定武装として装備されていました。また最高速マッハ1.4を発揮する格闘戦闘機でありながら、安価で機体維持が容易である理想的な機体で、導入当時 F-5A が戦闘機に要求される基本装備を十分に有する機材であったことから、アメリカの軍事援助計画によりイラン、韓国、フィリピン、トルコ、ギリシャ、および台湾 など各国空軍に広く採用・配備されたのです。そして空軍 戦闘機として導入した国のうち、カナダでは F-5A の機体を直接購入したのに加え、国内でのライセンス生産も行われ、その機体は CF-5A (カナダ空軍 正式型式名: CF-116) と呼称されました。オランダ J85-CAN0-15 ターボジェットエンジンに、空中給油プロブを装備するカナダ製の機体は、その後 NF-5A の型式名でオランダ空軍にも採用されました。ベトナム戦争の最中、同盟諸国に F-5A の戦闘実績を示す必要があったことから、アメリカ空軍は空中給油プロブに、対空兵器から機体を守る防弾装甲を追加装着させた特別仕様機で評価試験部隊を編成し実戦投入しました。その機体が投入された作戦は「スコスタイガー」と命名され、地上近接支援で活躍したと伝えられています。尚、作戦名の中の「スコシ」は日本語の「少し」に由来します。

CAUTION

- *Read carefully and fully understand the instructions before commencing assembly.
- *Keep out of reach of children. Children must not be allowed to put any parts in their mouths, or pull plastic bag over their heads.
- *When using adhesives and paints, please make sure not to use them in closed room or near the fire.
- *When assembling this kit, tools including knives are used. Extra care should be taken to avoid injury.

WARNING: CONTAIN SMALL PARTS NOT FOR CHILDREN UNDER 14 YEARS OF AGE.



Drill



Remove



2 Set



Bend



Optional



Decal



Super Glue



Fill Hole



No Cement



Be Careful

TOOLS RECOMMENDED

Cement



Side Cutter

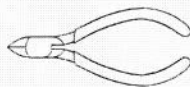

Modeling Knife

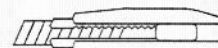

Tweezers



1/48 SCALE AIRCRAFT SERIES NO: 48020

A

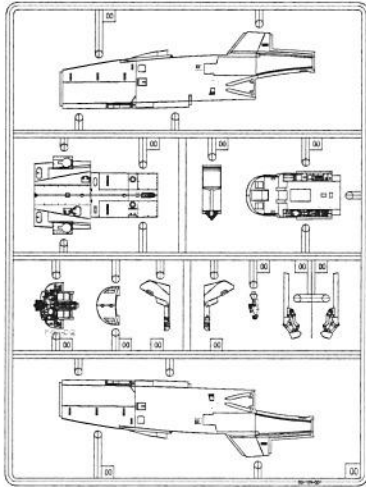

B

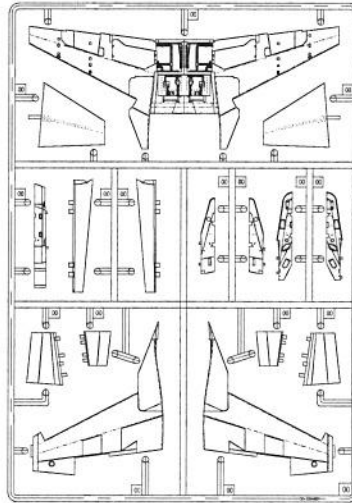

C X 2

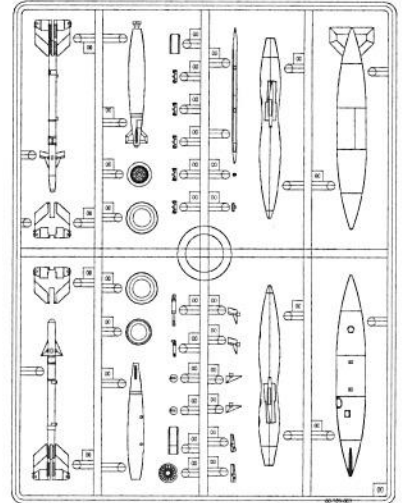

D

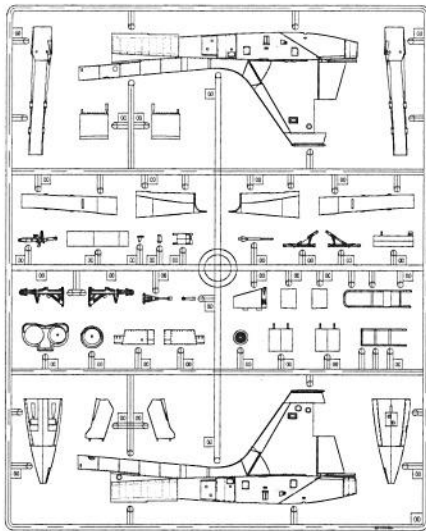

E

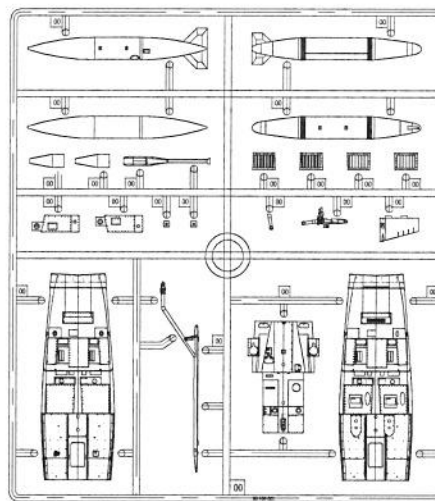

F

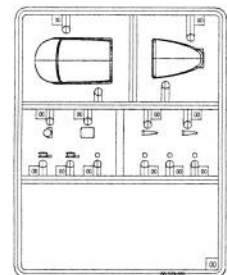

PE

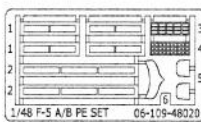

Thank you the following for their help in the production of this model:
Pawel, Krupowica, Rick Chin, and Cold Lake Museum.

1/48 SCALE AIRCRAFT SERIES NO:48020

AFTERMARKET SERVICES CARD

When requesting replacement parts, please take or send this form to your local dealer so that the parts required can be correctly identified. Please note that specifications and availability are subject to change without notice.

For more information, please contact services@kineticmodel.com or visit <http://www.kineticmodel.com> for latest information.

Parts Code	Item 48020
00-109-001.....	A part
00-109-002.....	B part
00-109-003.....	C part
00-109-004.....	D part
00-109-005.....	E part
00-109-006.....	F part
01-109-48020A.....	Decal
01-109-48020B.....	Decal
06-109-48020.....	PE Parts
03-109-48020.....	Manual

PAINTING GUIDE

	MR. COLOR	HOBBY COLOR	VALLEJO
Flat Black	33	12	950
Insignia White	316	316	842
Silver	8	8	997
Aircraft Gray	73	57	
Fluorescent Red	171		
Blue Gray	337	337	987
FS 36307 Gray	324	324	
FS 36251 Gray	317		
FS 34064 Green	302		
Dark Blue Gray	36	68	867
Sky Grey			989
Yellow Olive	120	330	892
Basalt Gray	37	69	
Silver Gray	334	334	990
Dark Gray	305	305	867
FS 36320 Gray	307	990	307
FS 36270 Gray	306	306	870
Navy Blue	72	42	903
Tan	310	310	874
Dark Green	303	303	890
Forest Green	309	309	893
Light Gray	311	311	883
Red	3		926

1

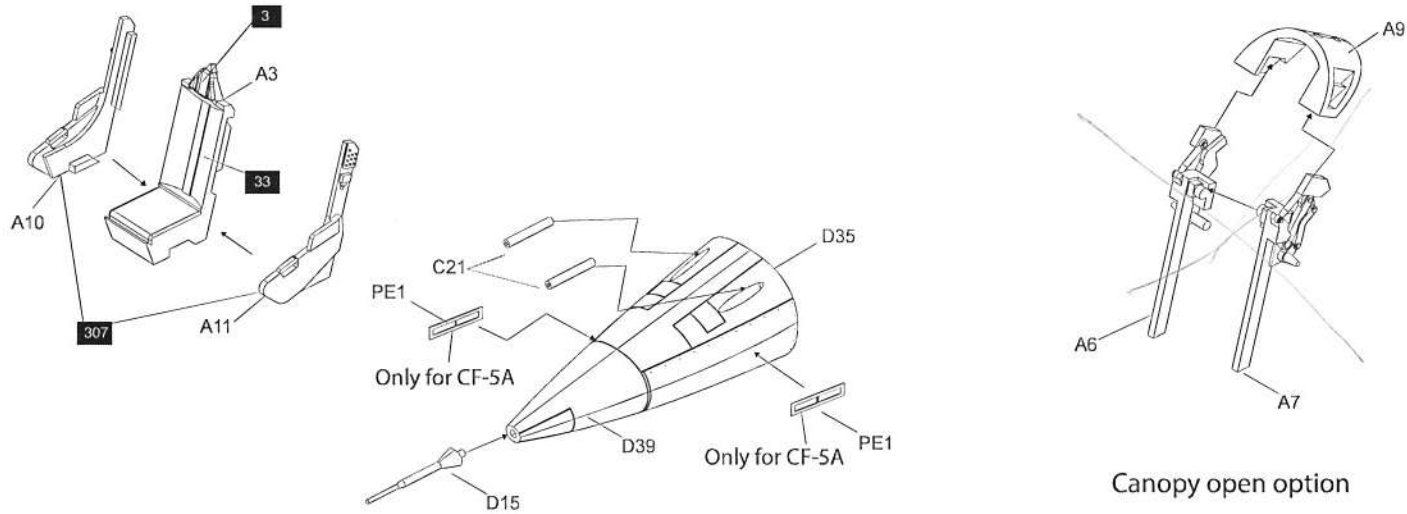

2

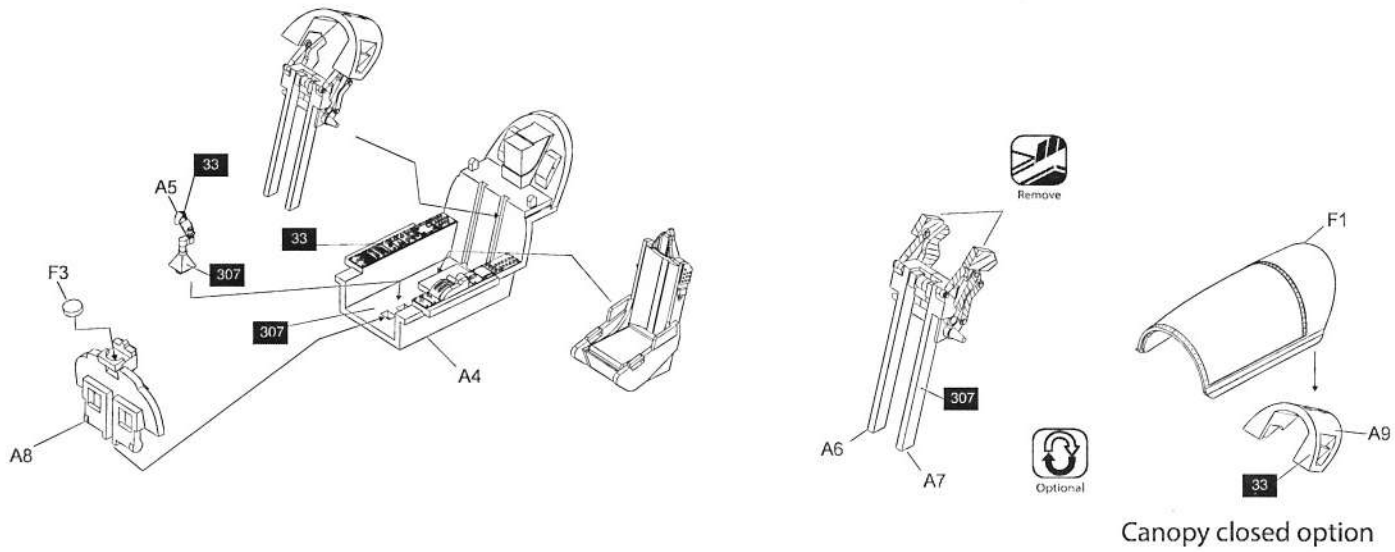

3

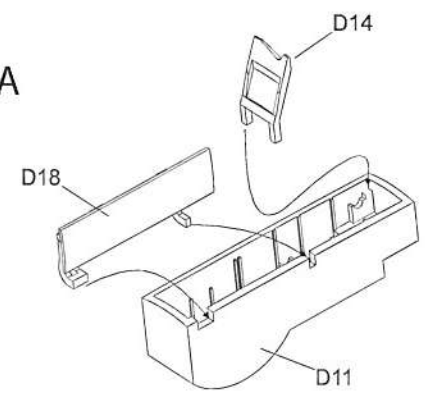
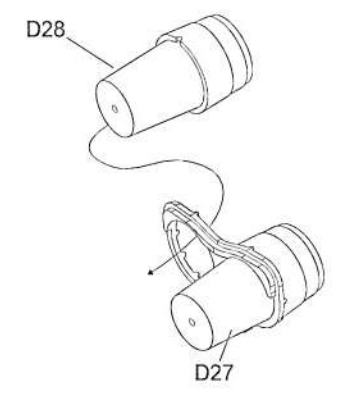
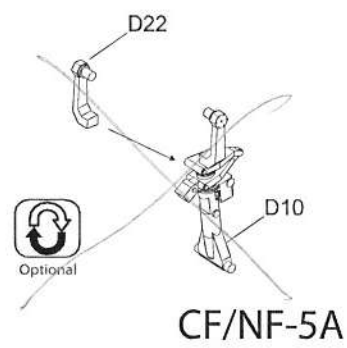
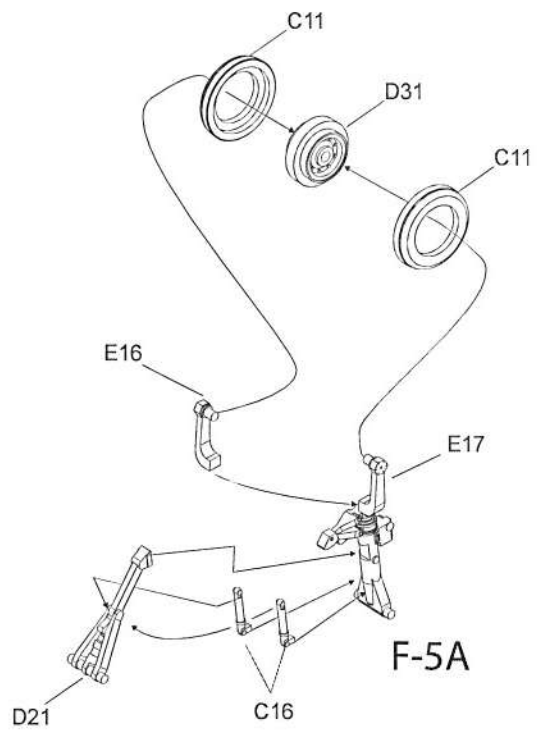

4 F-5A ONLY

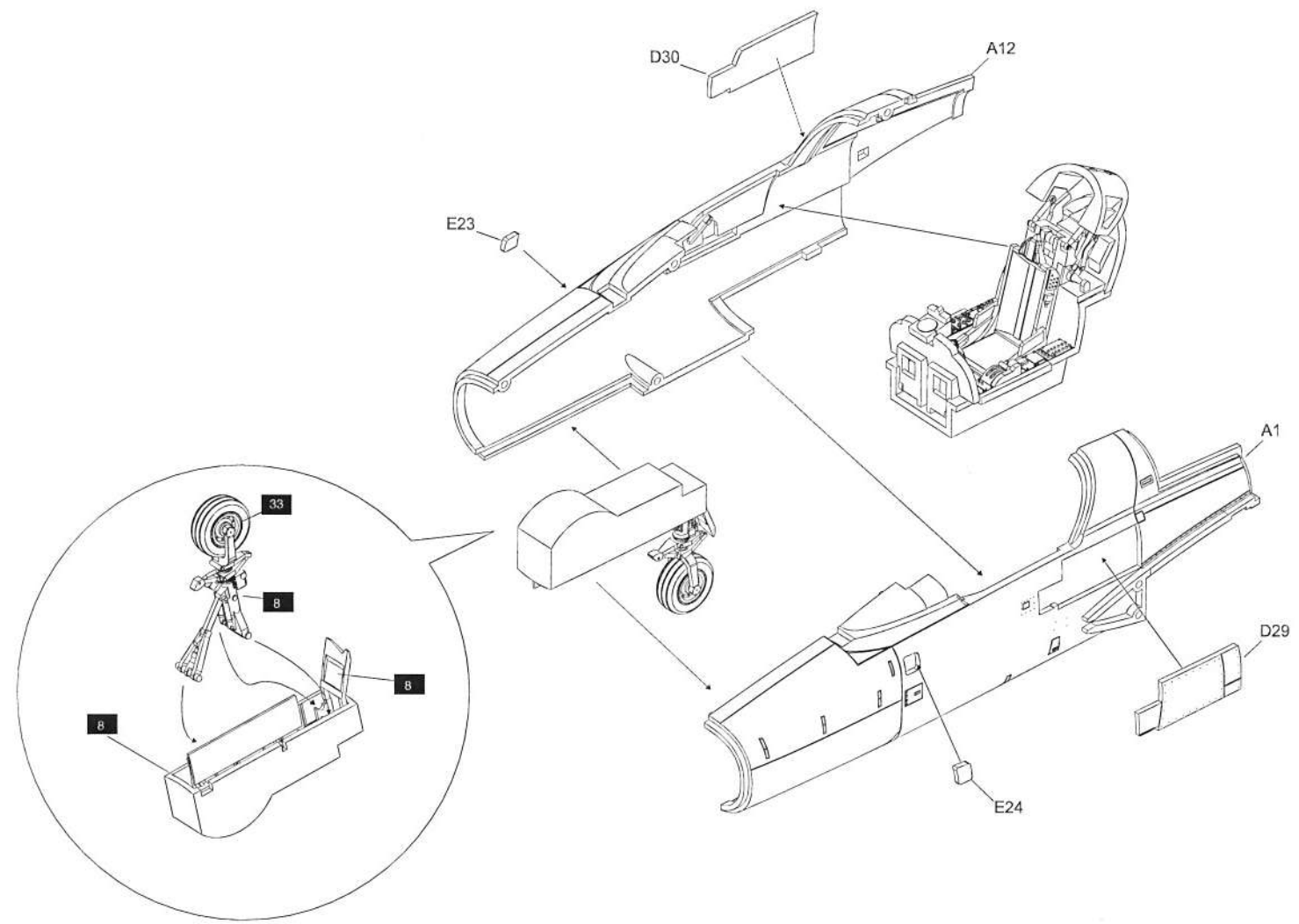

4A

CF/NF-5A

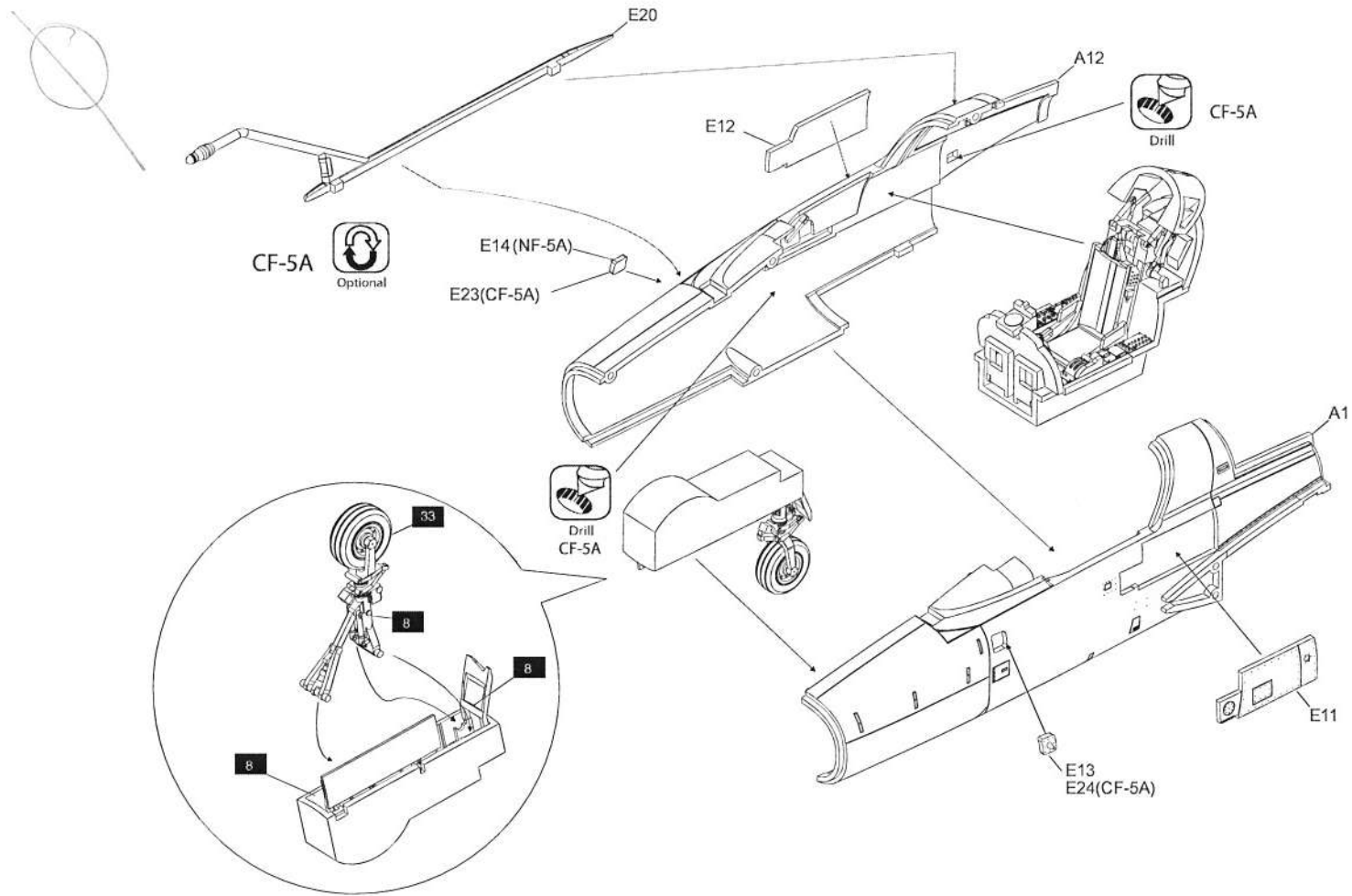

5

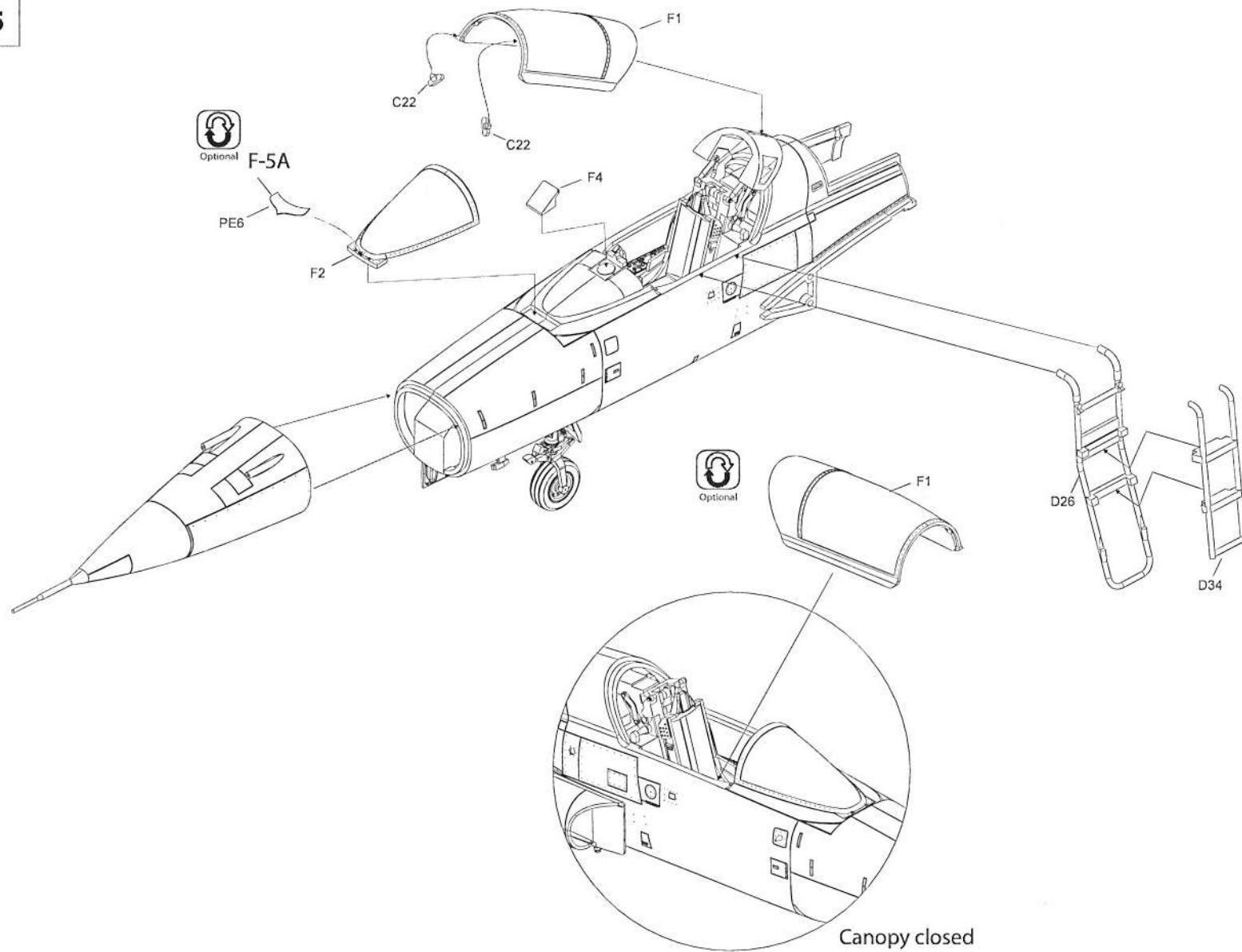

6 F-5A

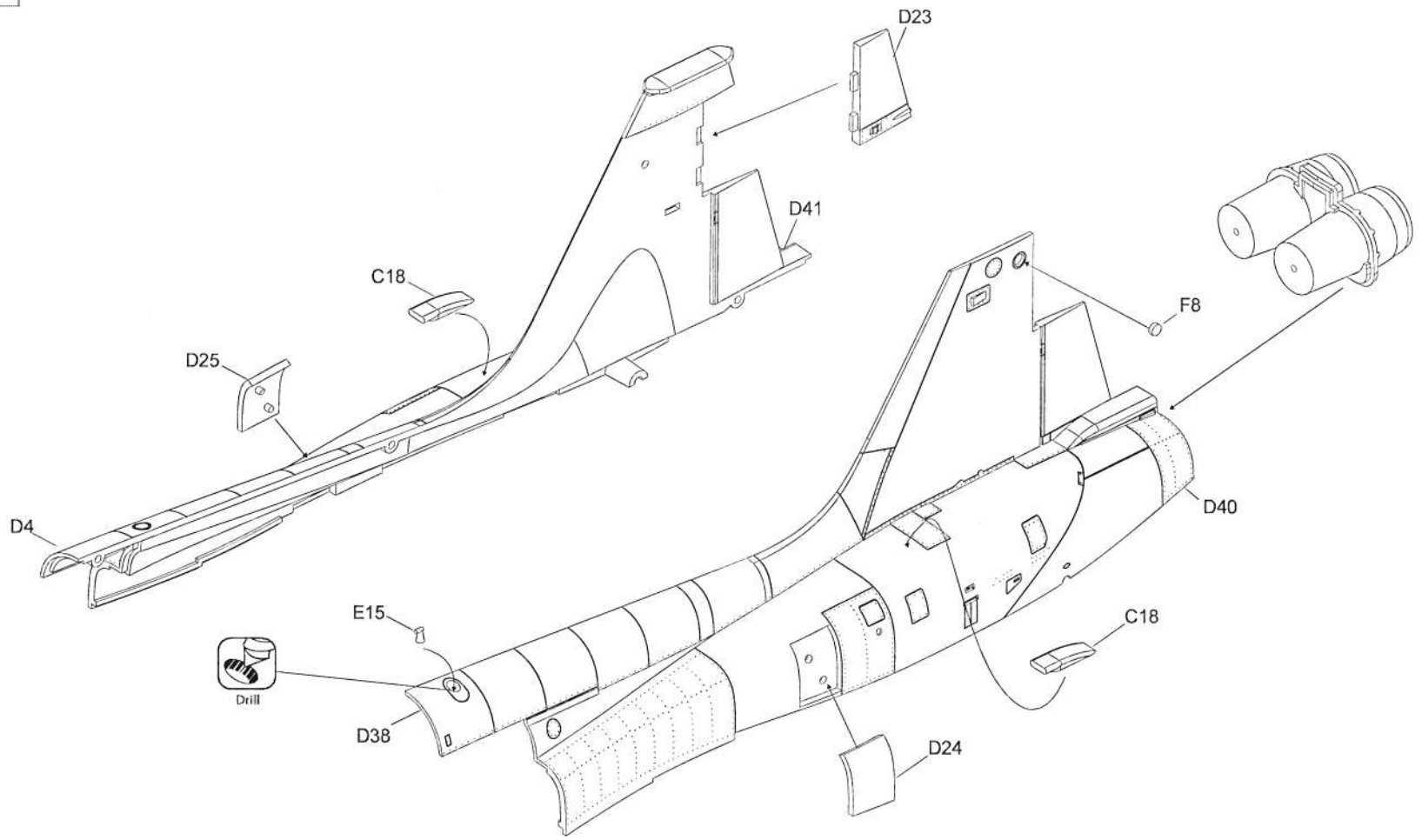

6A

CF-5A/NF-5A

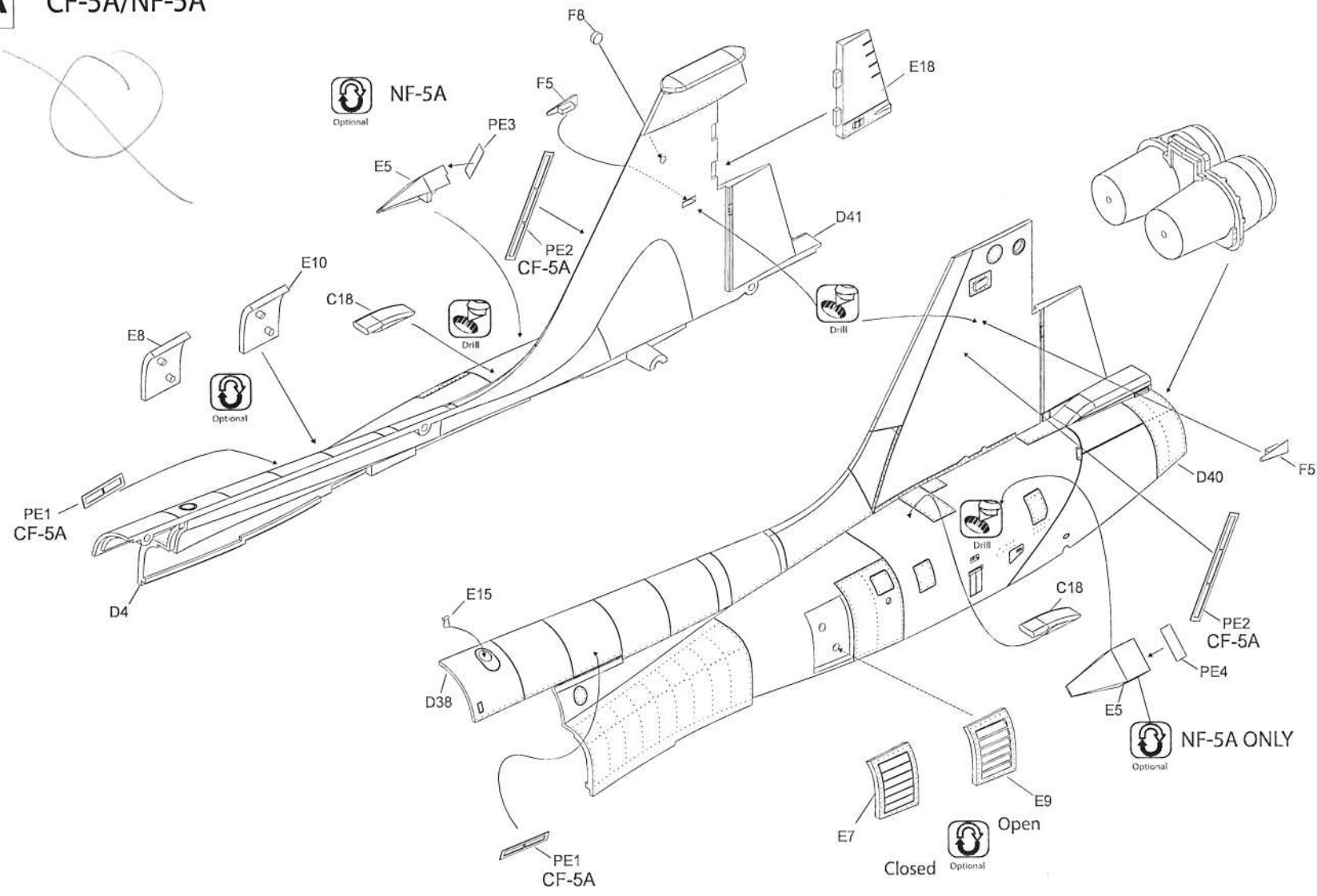

7

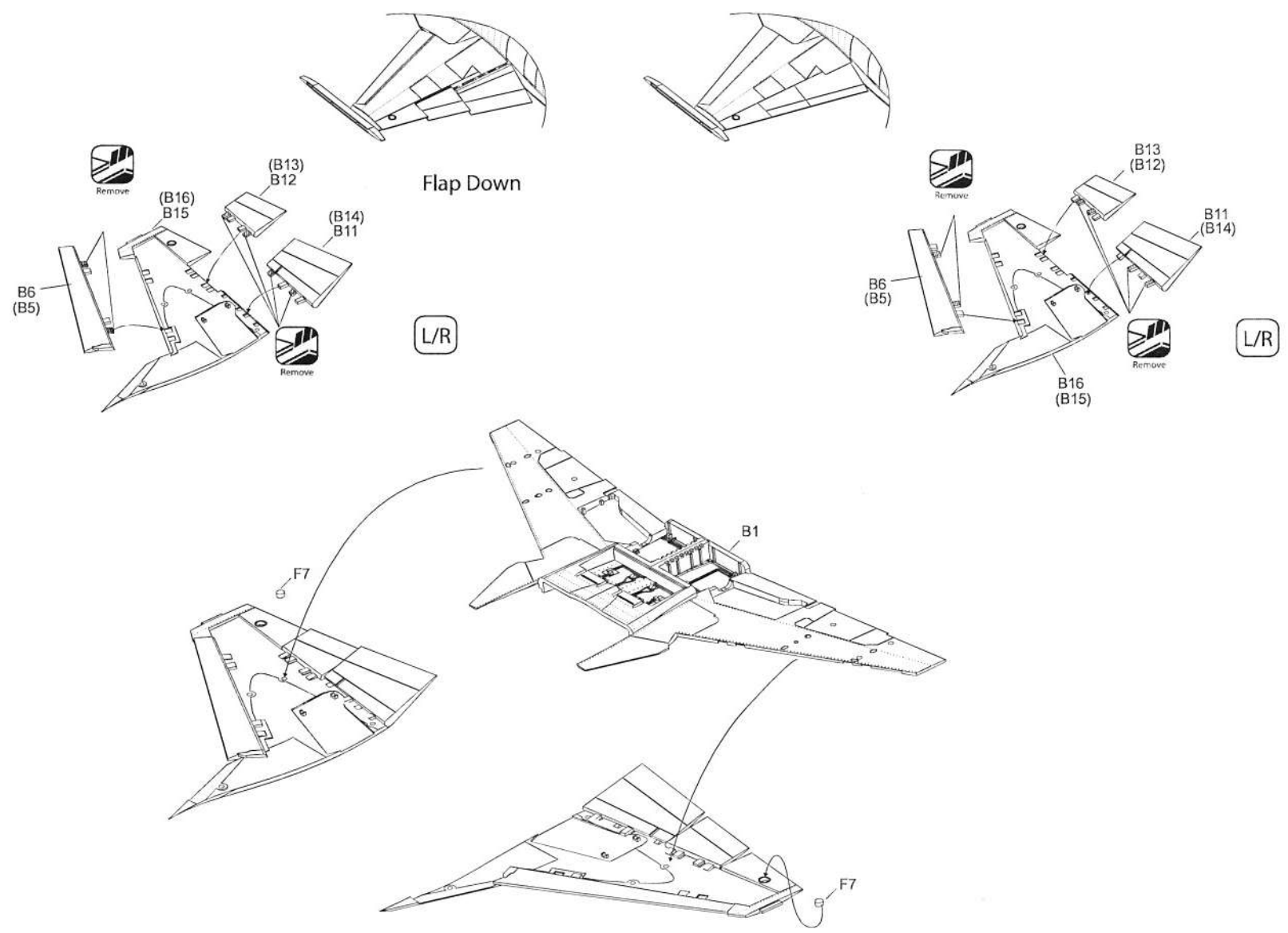

8

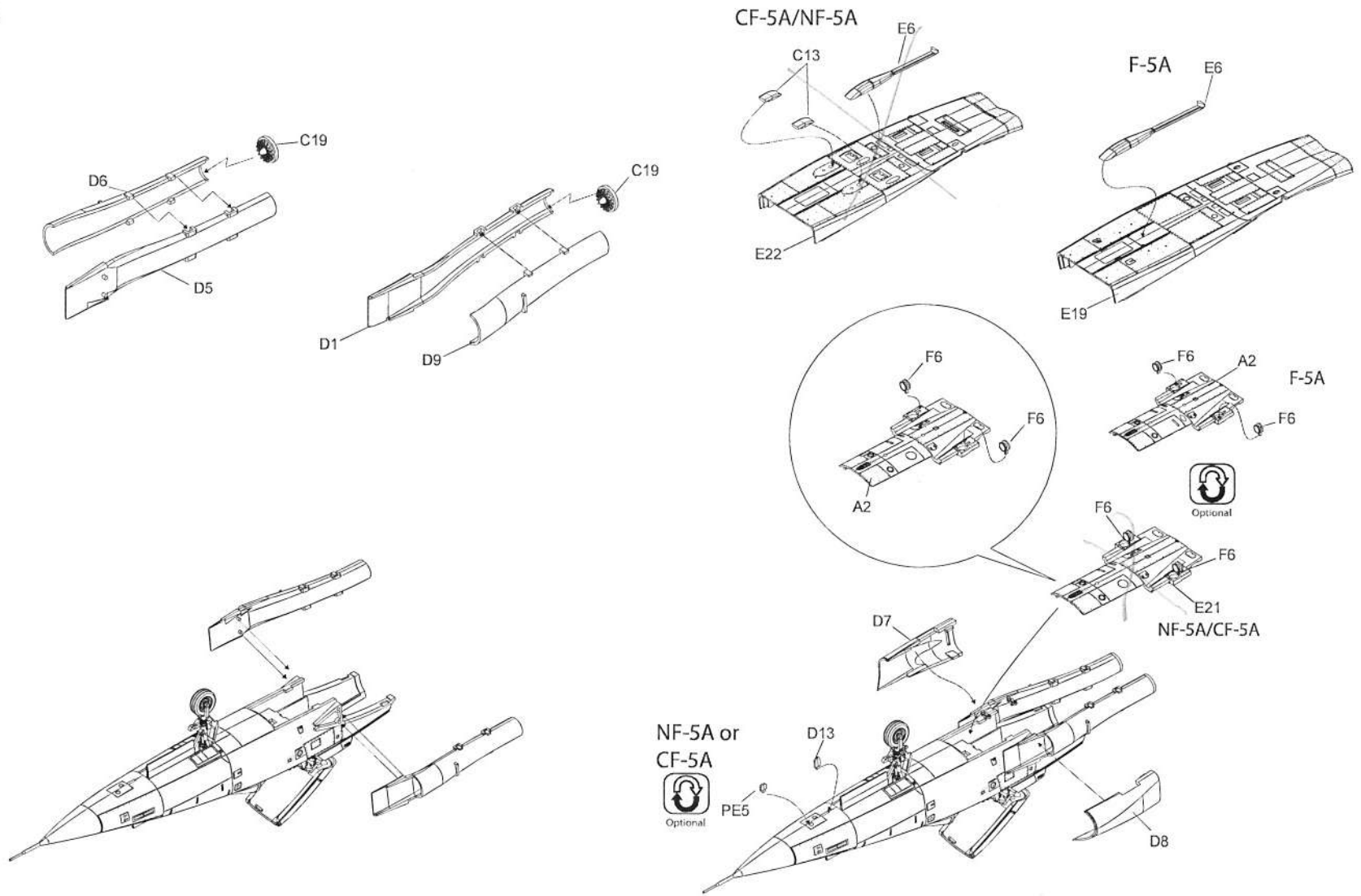

9

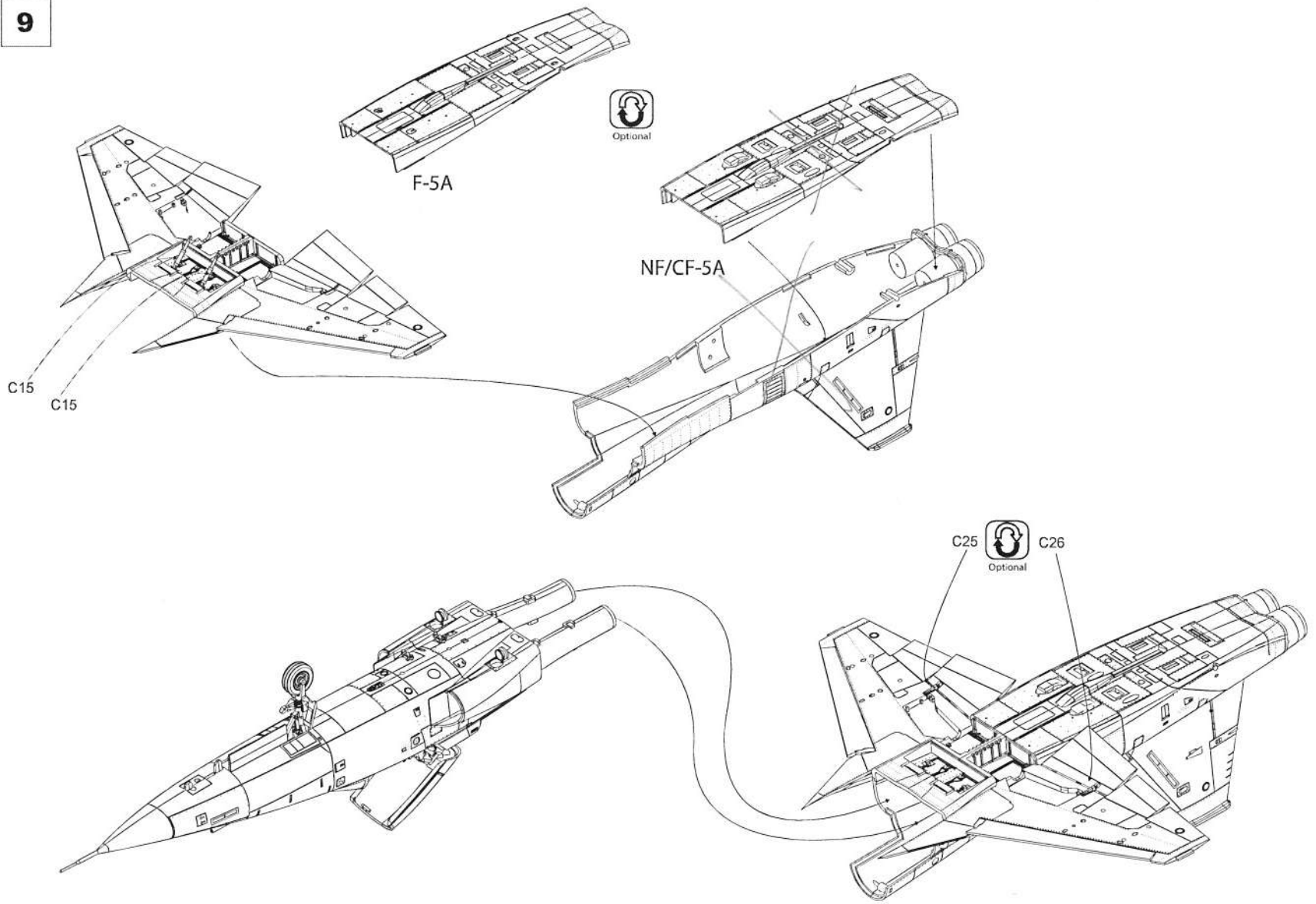

10

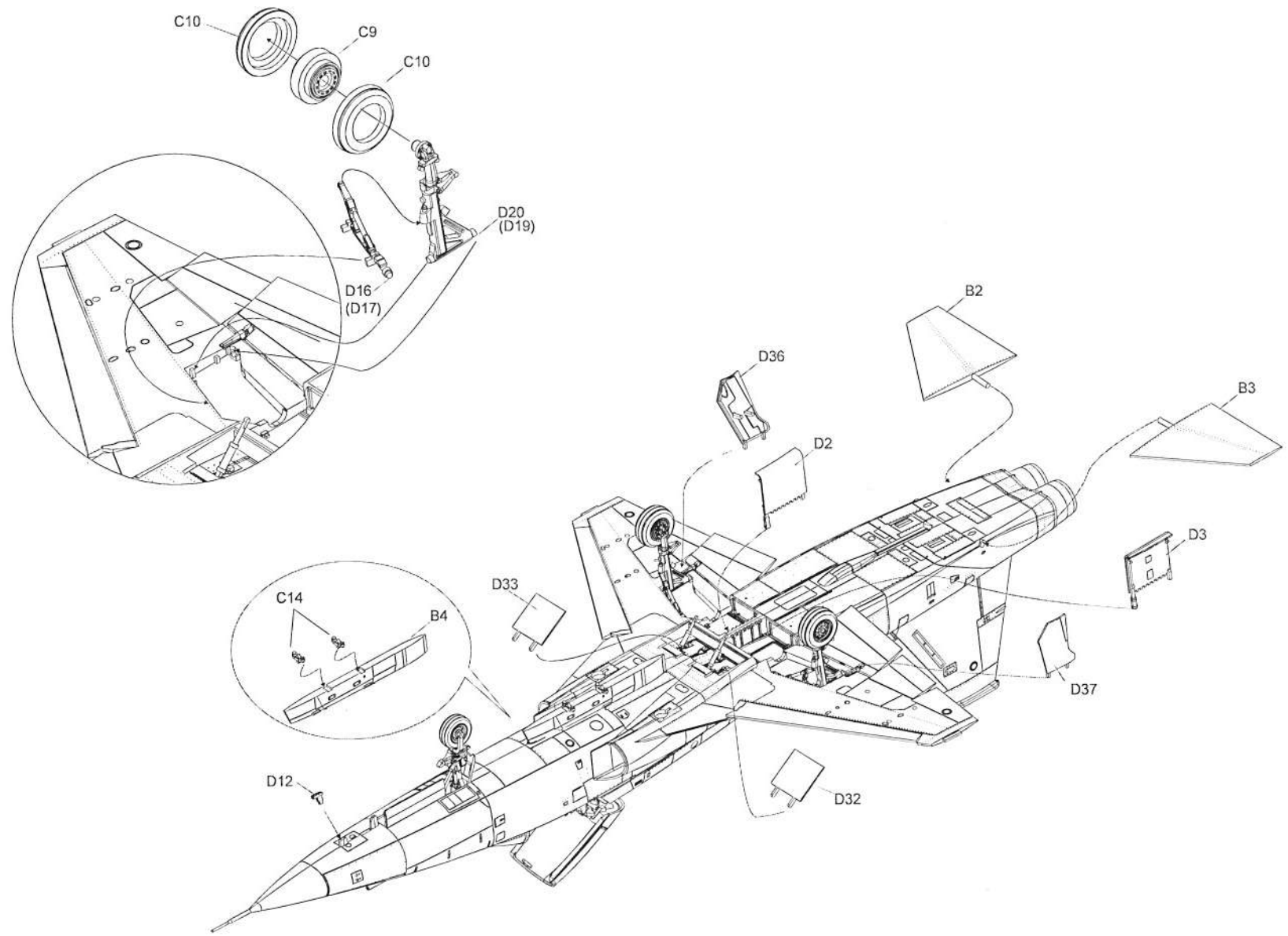

11

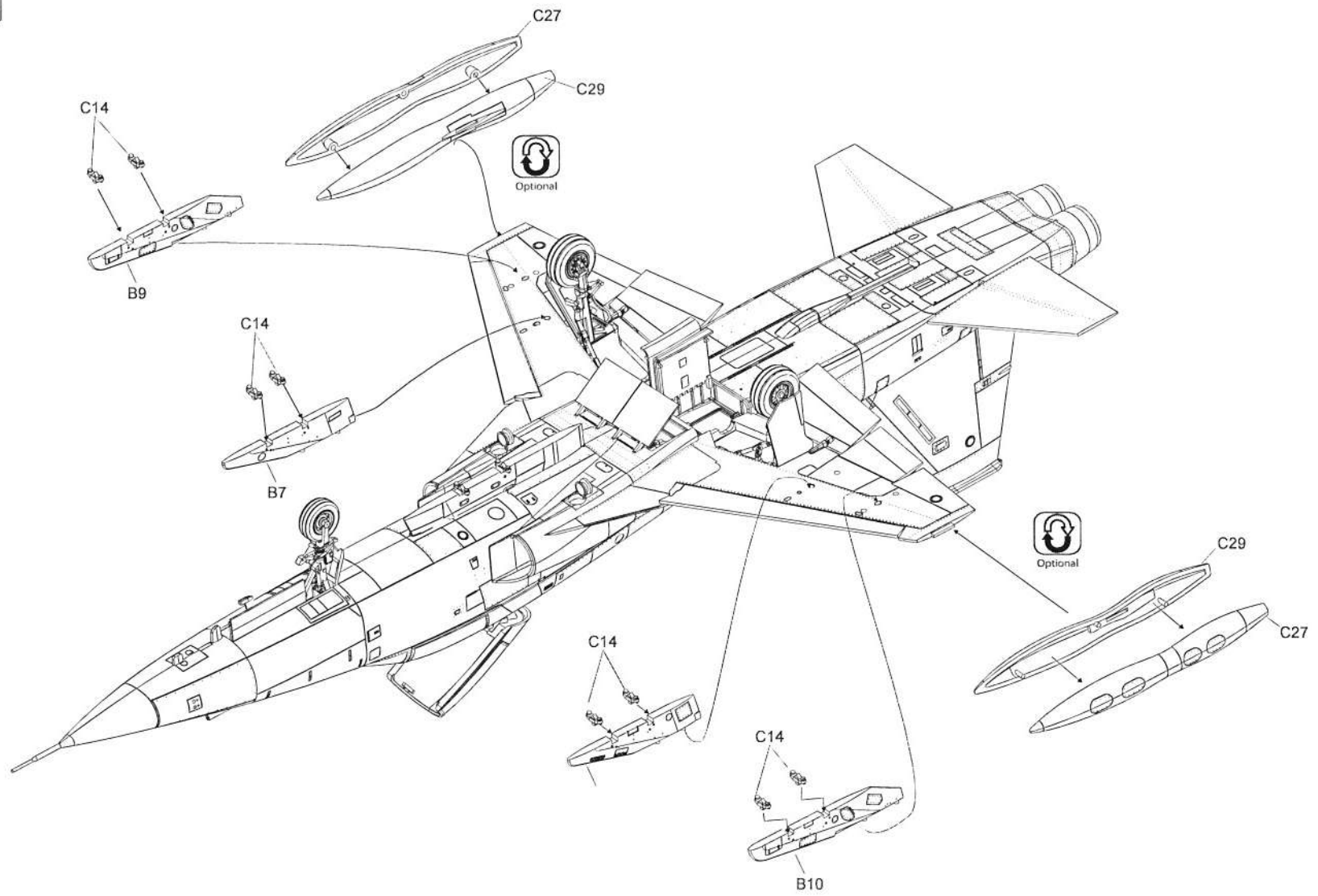

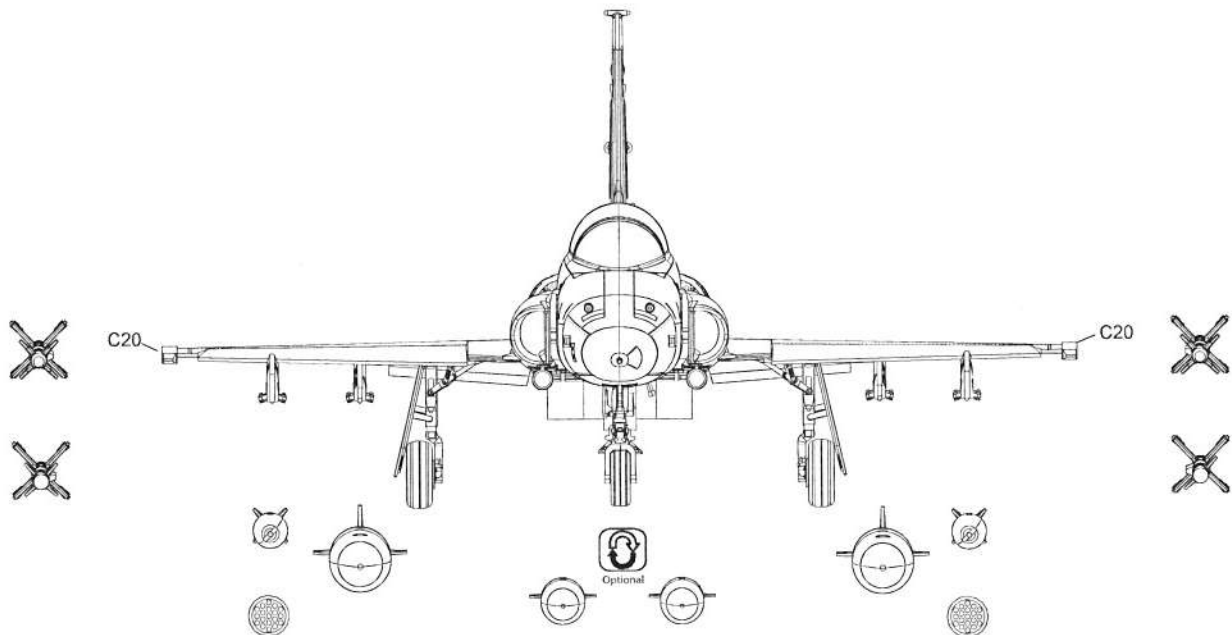

Centerline Fuel Tank #1

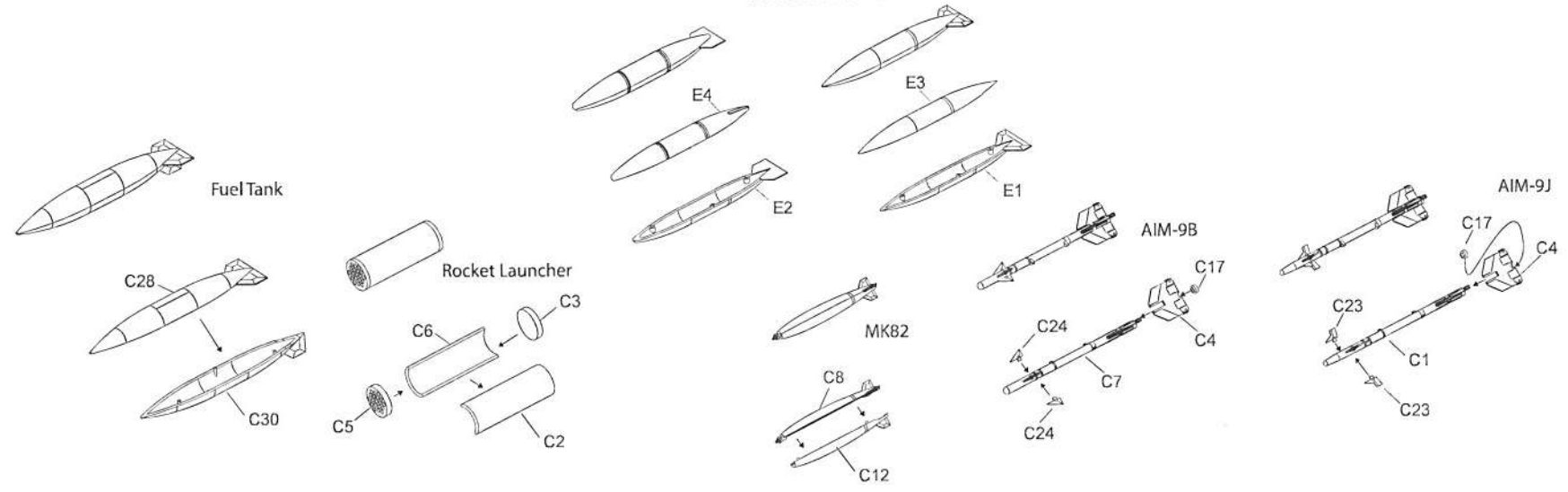

1. 59-4989, USAF. 3rd production of F-5A prototype. Used for operational test.
 Now in exhibition at National Museum of the U.S. Air Force.

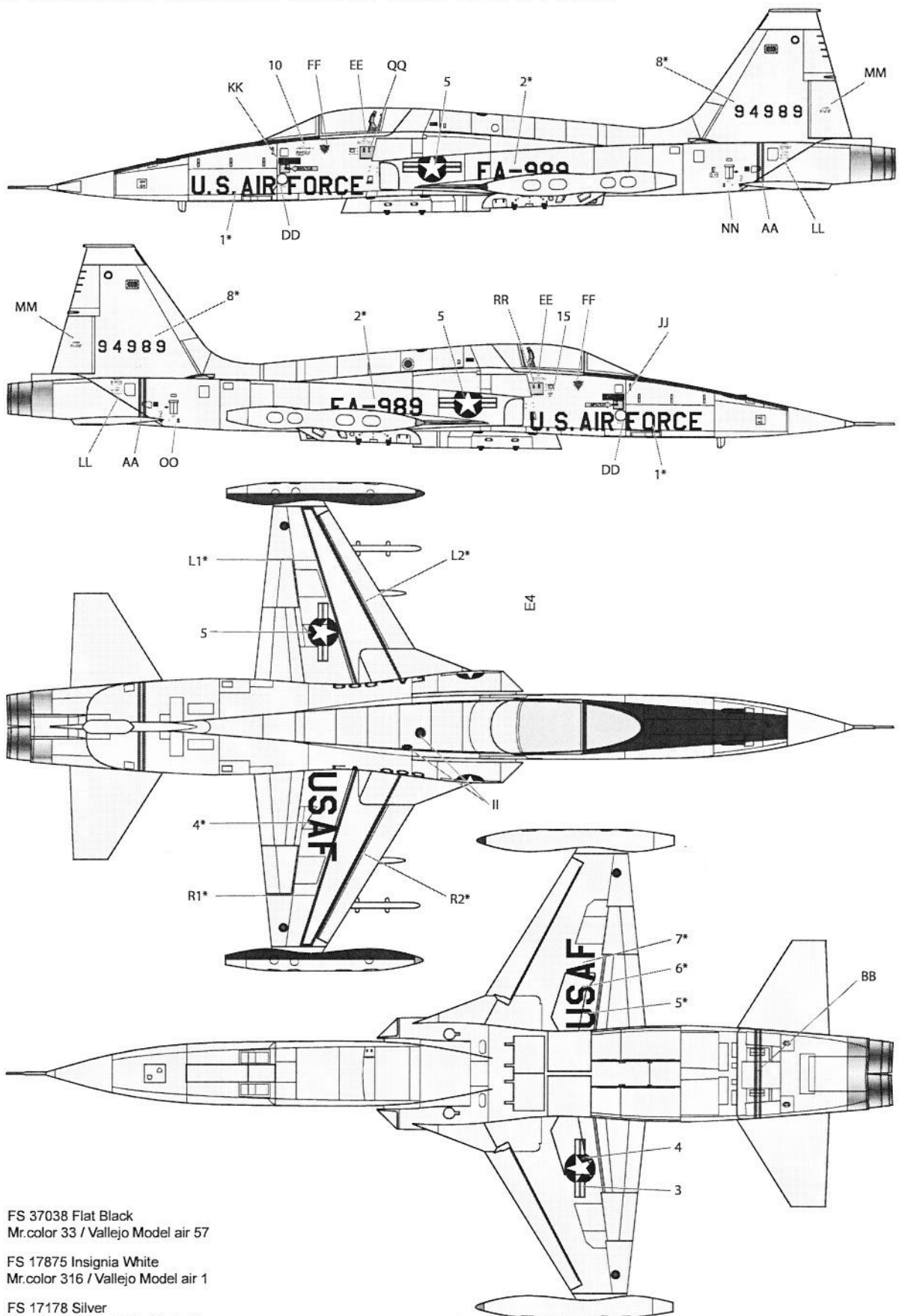

- FS 37038 Flat Black
Mr.color 33 / Vallejo Model air 57
- FS 17875 Insignia White
Mr.color 316 / Vallejo Model air 1
- FS 17178 Silver
Mr.color 8 / Vallejo Model air 64

2. 63-8381, USAF. Before its delivery to its contractor, Greece, training was done in 4441st Combat Crew Training School (CCTS) at Williams AFB, wearing USAF TAC marking.

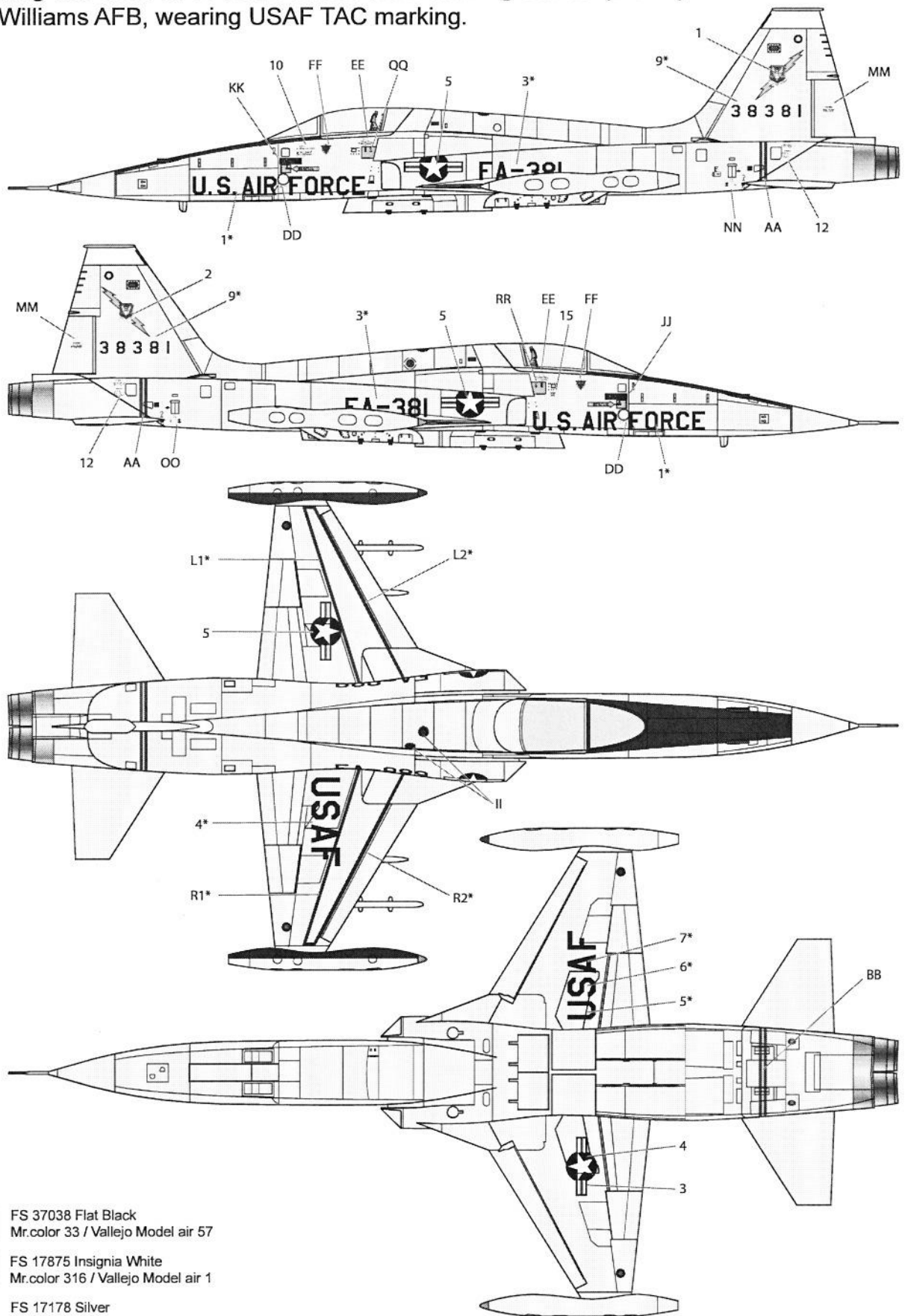

3. 63-8381, USAF. The delivery to Greece was not made until 1988; it was flown by Kelly AFB for the period.

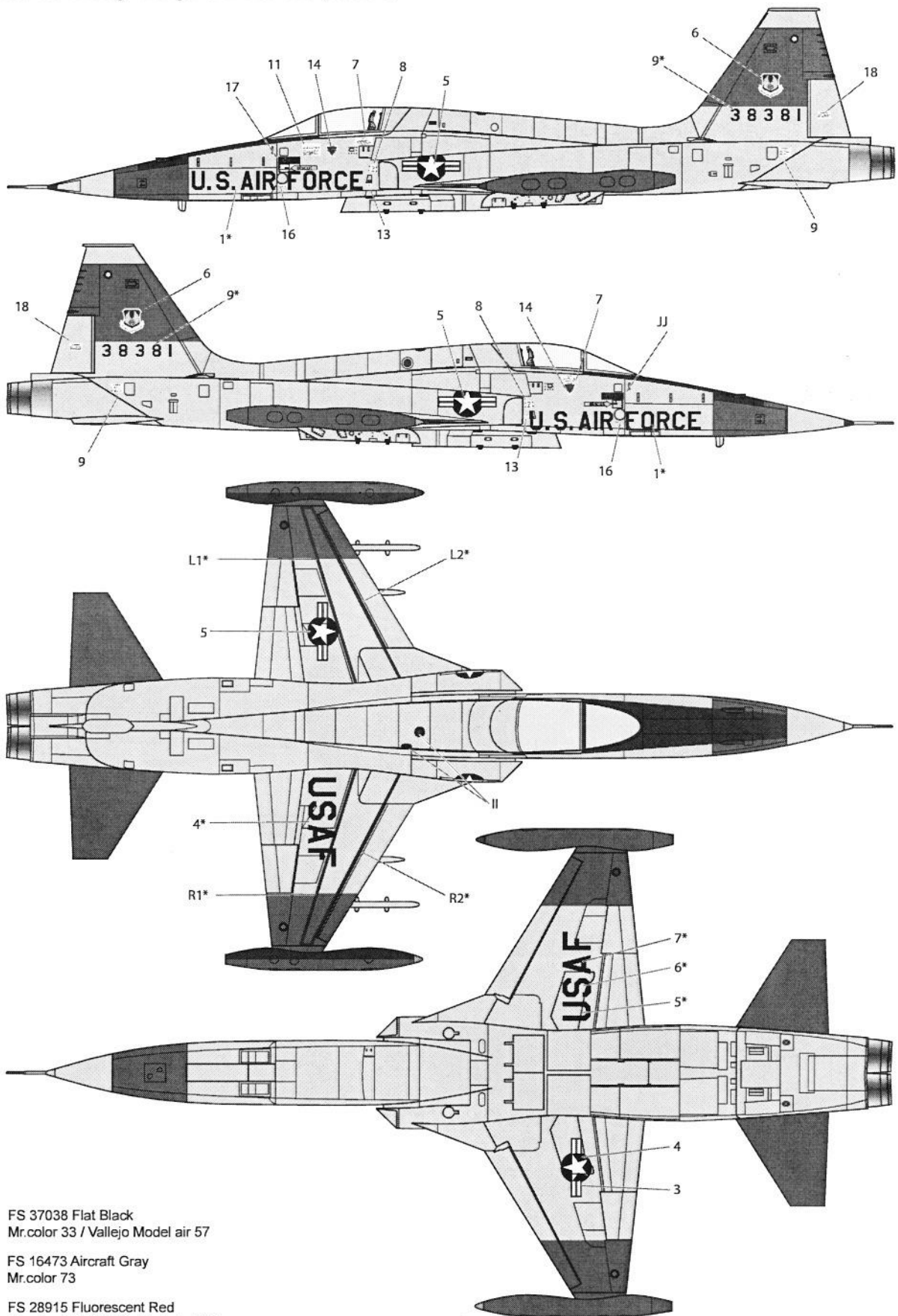

4. Canadian Armed Forces CF-116 116757 / 116727, 1995.
 116757 is stored in Canadian warplane heritage, wearing its last
 camouflage scheme at its retirement, 1995.

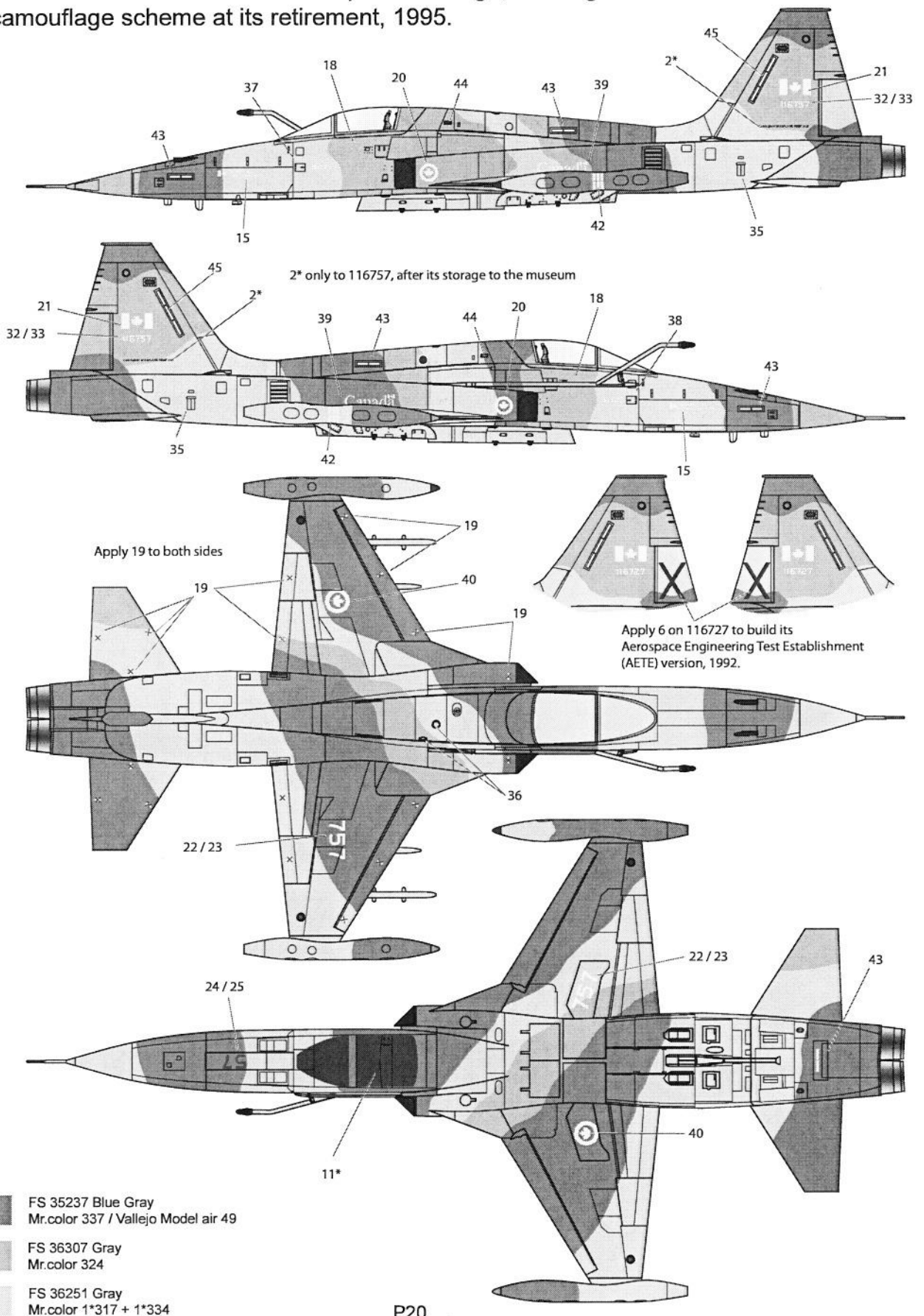

- FS 35237 Blue Gray
 Mr. color 337 / Vallejo Model air 49
- FS 36307 Gray
 Mr. color 324
- FS 36251 Gray
 Mr. color 1*317 + 1*334

5. Canadian Armed Forces CF-116 116763, No.434 "Bluenose" Squadron, in aggressor scheme, 1988. Retired and on exhibition at Canada Aviation and Space museum, Ottawa, Canada.

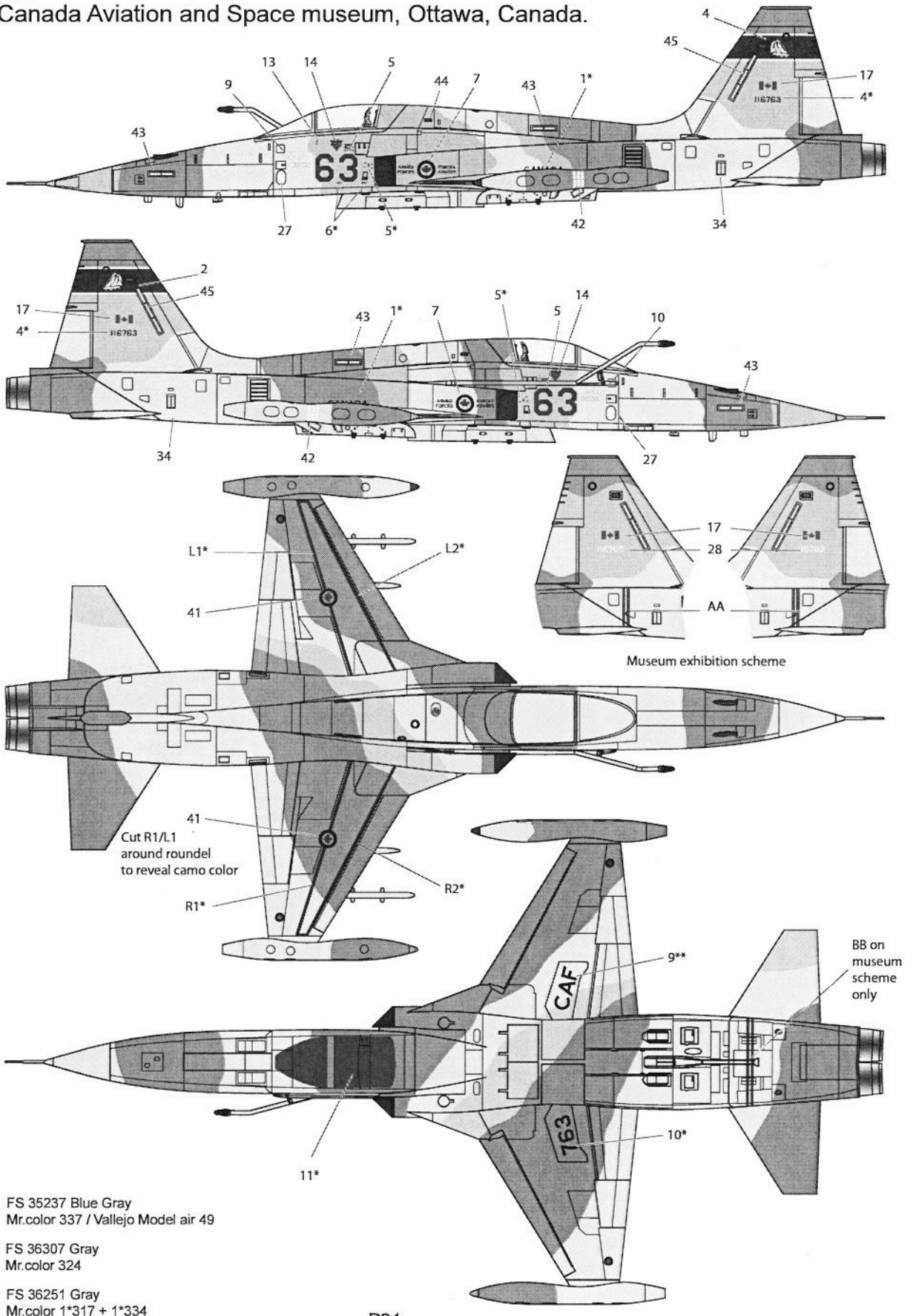

6. Canadian Forces CF-116, No.434 "Bluenose" Squadron, 1979.

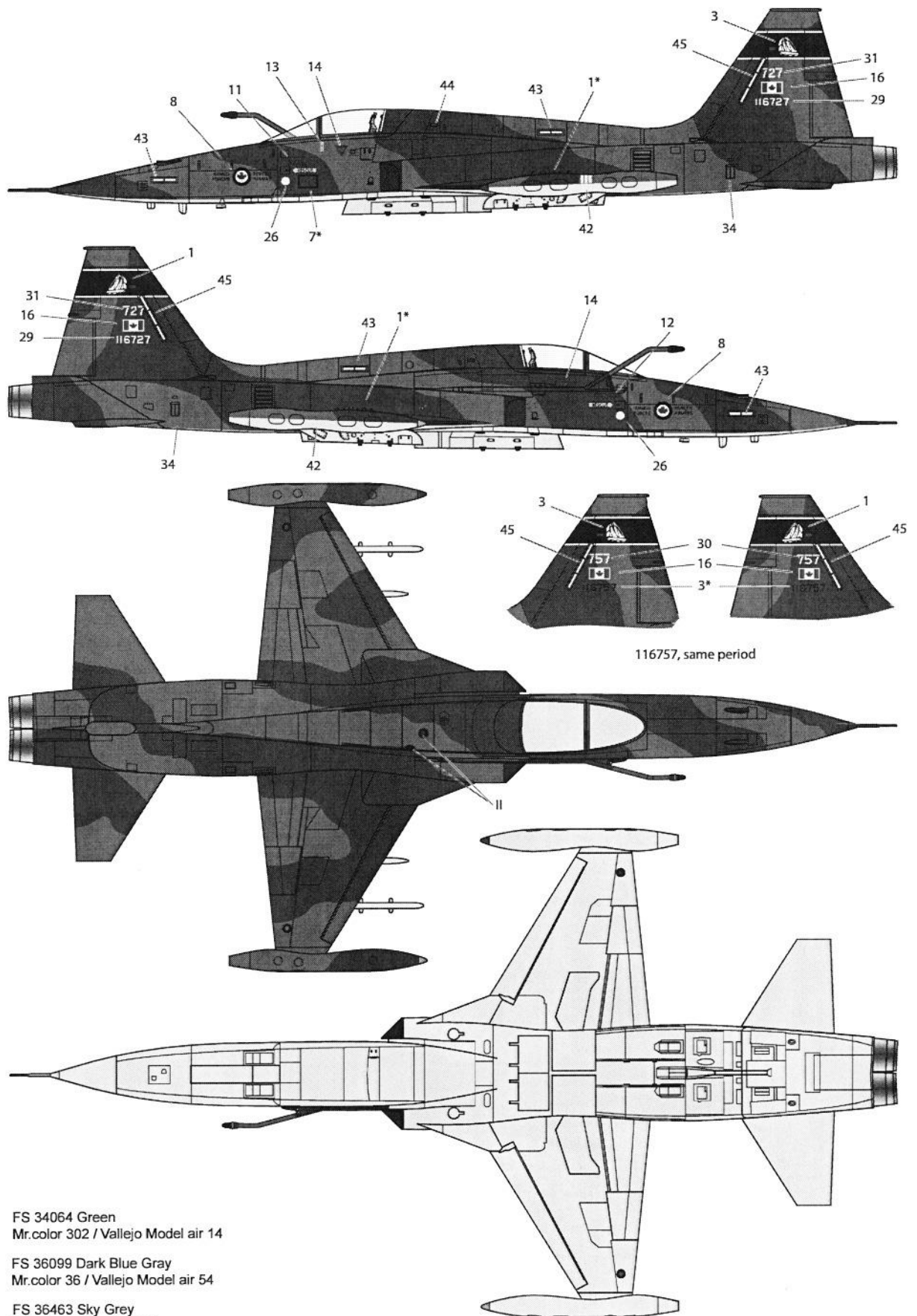

- FS 34064 Green
Mr.color 302 / Vallejo Model air 14
- FS 36099 Dark Blue Gray
Mr.color 36 / Vallejo Model air 54
- FS 36463 Sky Grey
Vallejo model color 989

7. Netherland Air Force NF-5A, 315 Squadron, 1979.

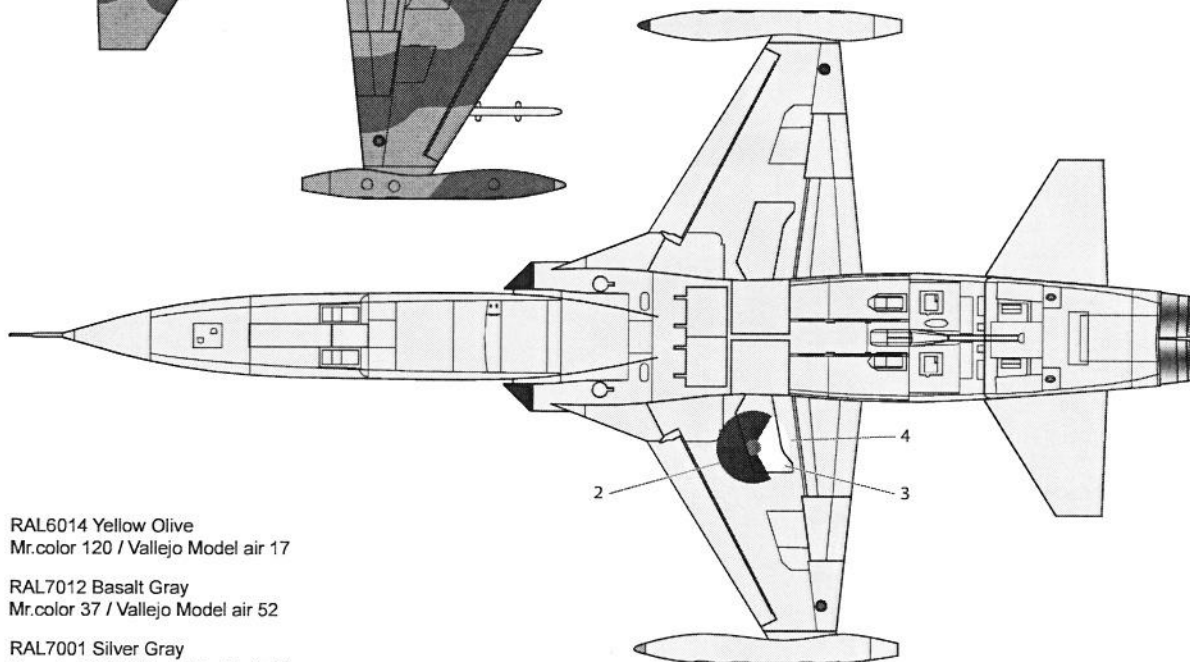
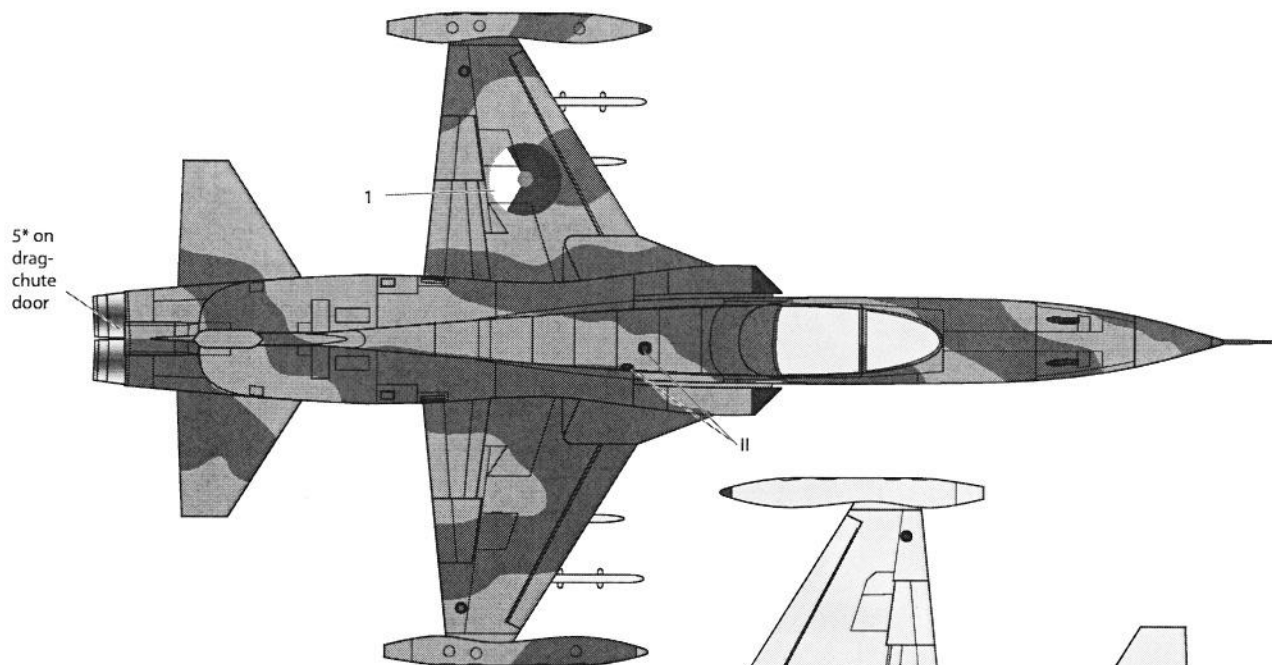
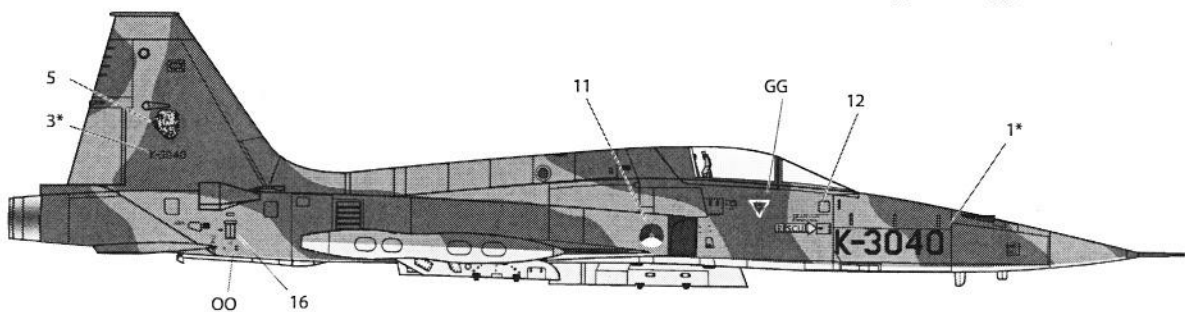
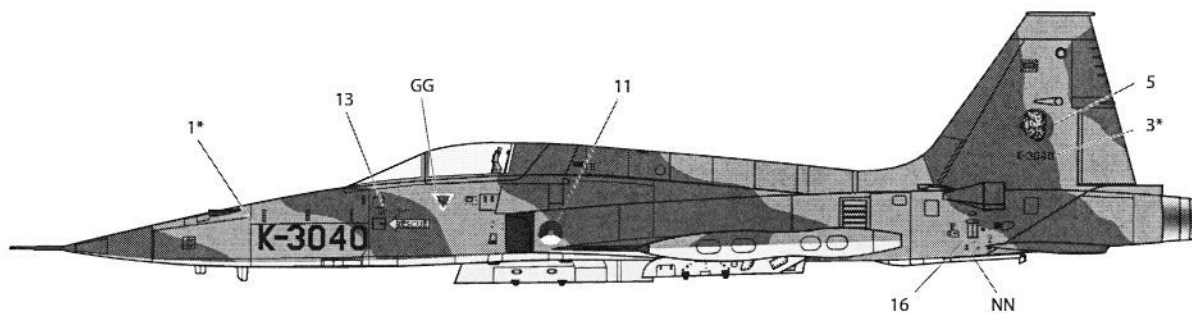

- RAL6014 Yellow Olive
 Mr.color 120 / Vallejo Model air 17
- RAL7012 Basalt Gray
 Mr.color 37 / Vallejo Model air 52
- RAL7001 Silver Gray
 Mr.color 334 / Vallejo Model air 51

8. Netherland Air Force NF-5A, 315 Squadron, 1985.

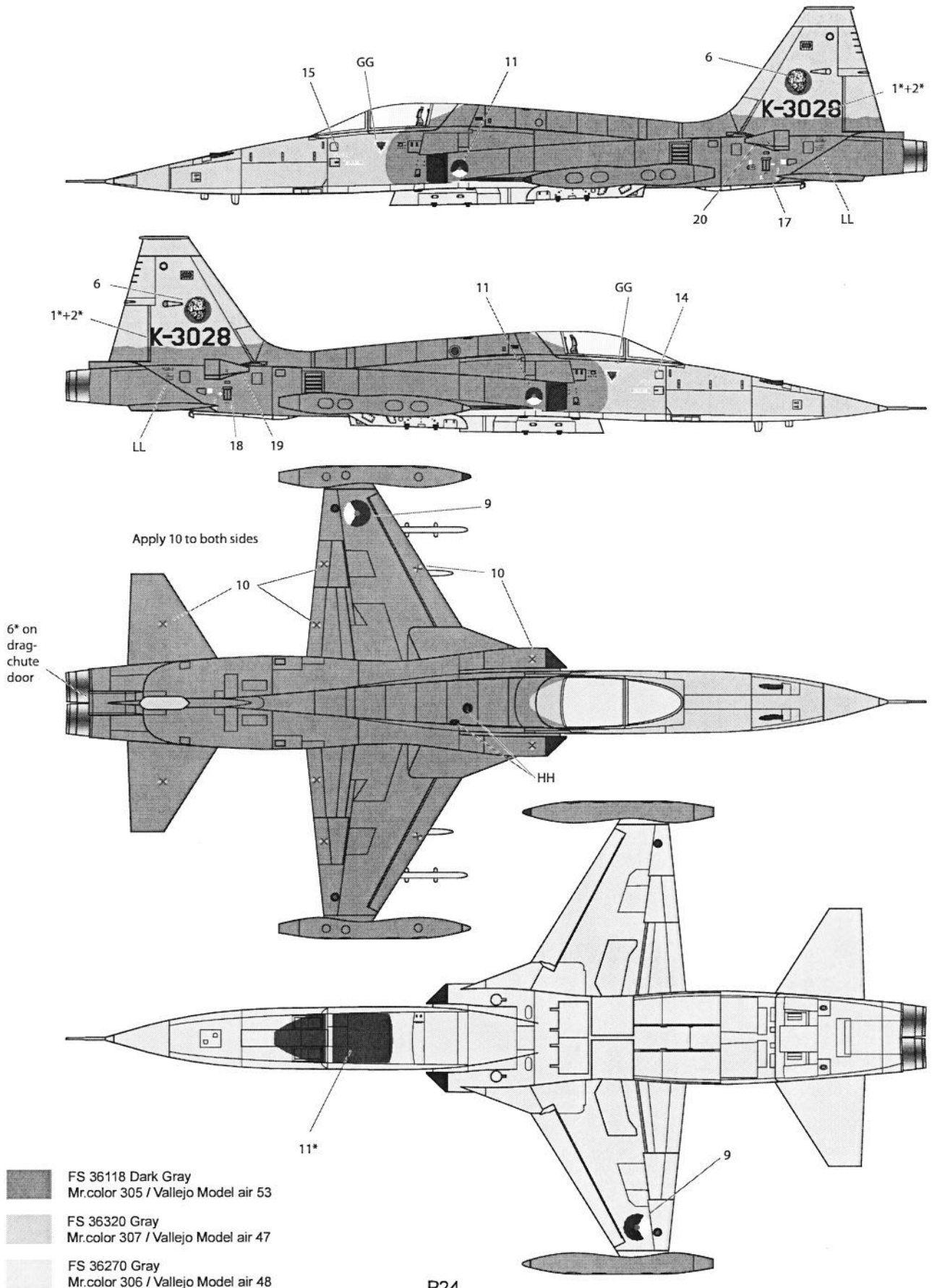

9. Royal Norwegian Air Force F-5A, Acrobatic team "Flying Jokers",
336 Squadron, International Air Tattoo, RAF Faiford, 1977.

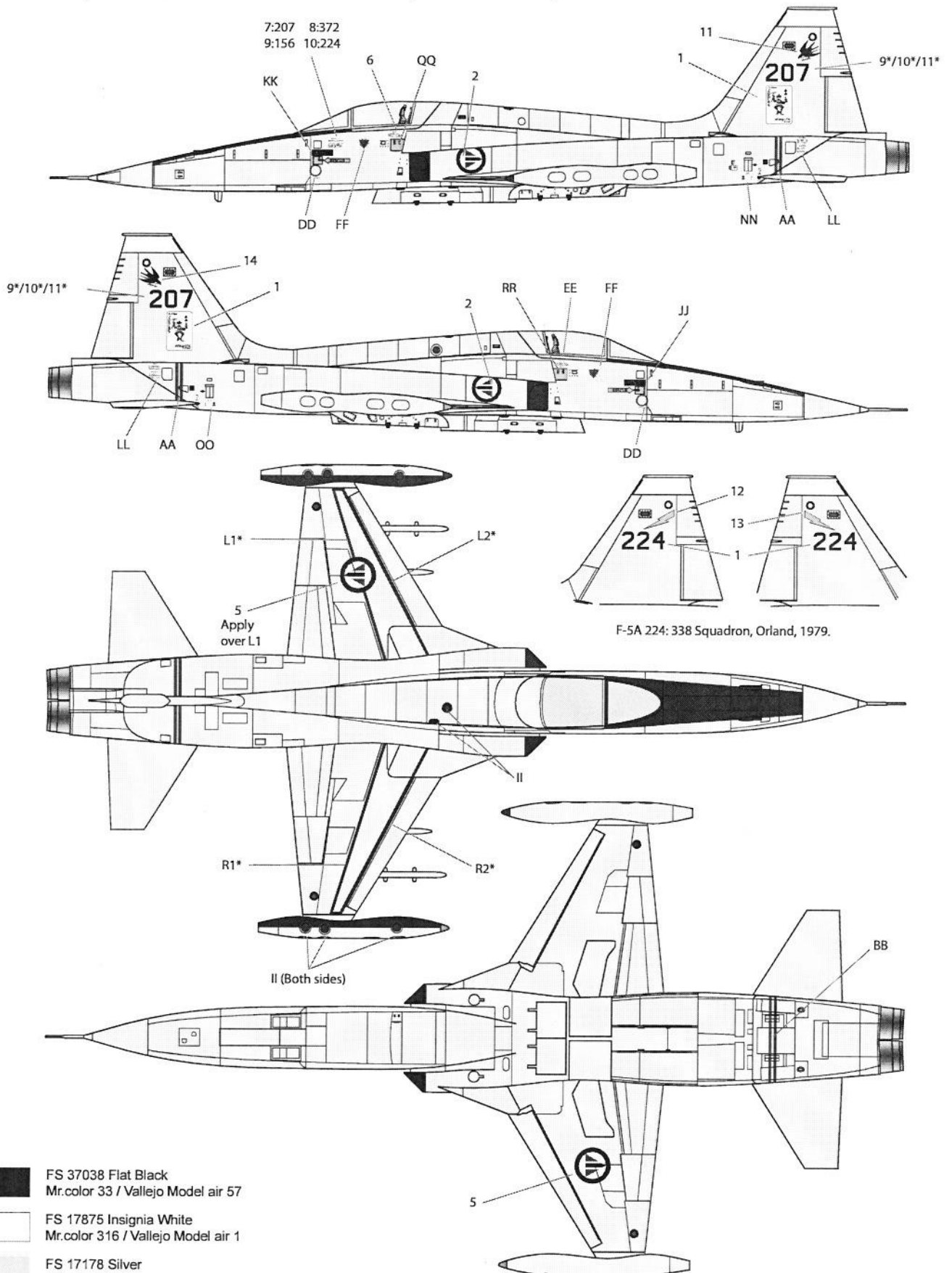

10. Royal Norwegian Air Force F-5A, 334 Squadron, Bodo, 1969.

66-9222 : RI-I
 66-9223 : RI-K
 66-9224 : RI-L

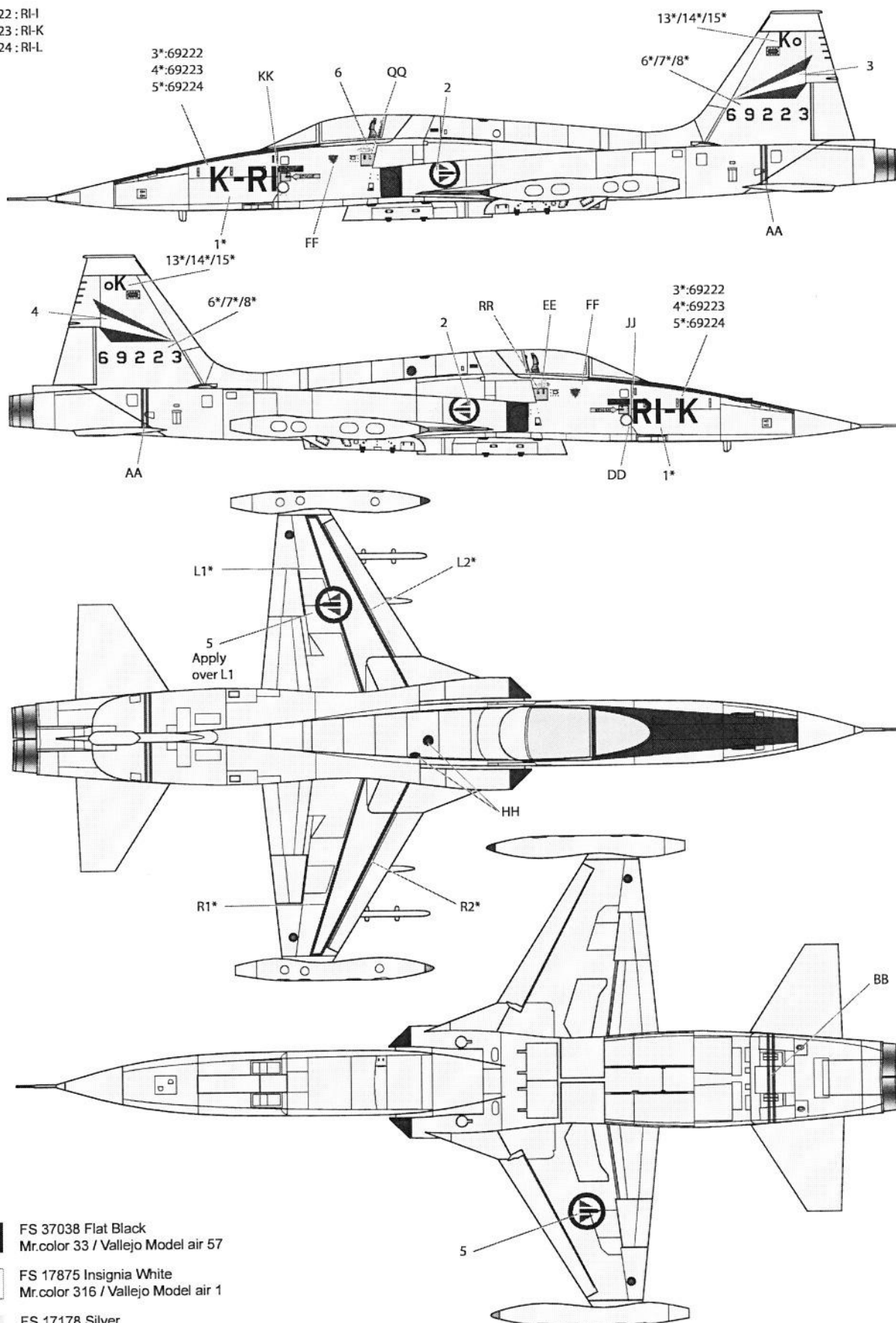

- FS 37038 Flat Black
 Mr.color 33 / Vallejo Model air 57
- FS 17875 Insignia White
 Mr.color 316 / Vallejo Model air 1
- FS 17178 Silver
 Mr.color 8 / Vallejo Model air 64

11. Greek Air Force F-5A, 341st "Arrow" Squadron, 1992.

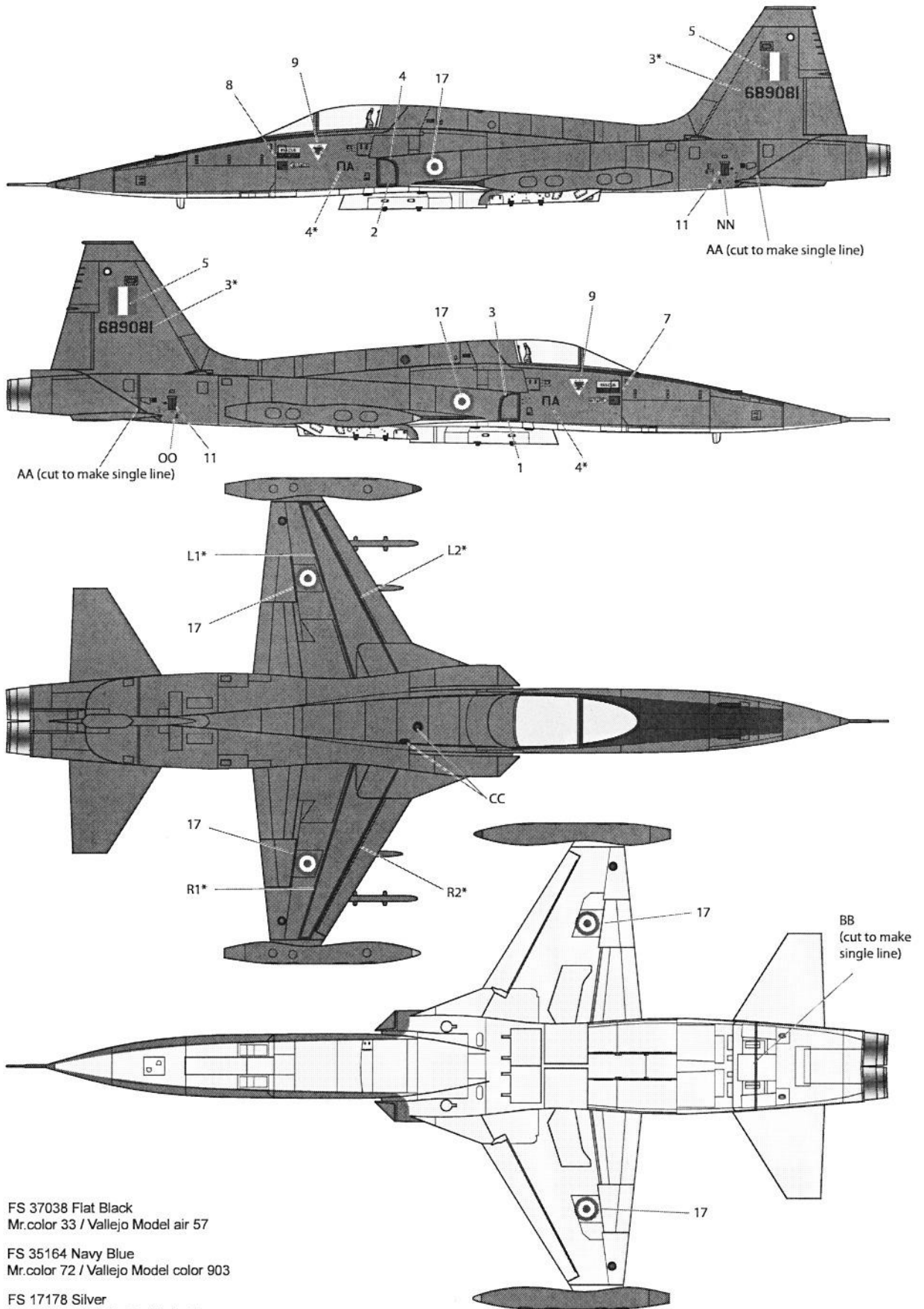

- FS 37038 Flat Black
 Mr.color 33 / Vallejo Model air 57
- FS 35164 Navy Blue
 Mr.color 72 / Vallejo Model color 903
- FS 17178 Silver
 Mr.color 8 / Vallejo Model air 64

12. Greek Air Force F-5A, 341st "Arrow" Squadron, 1998.

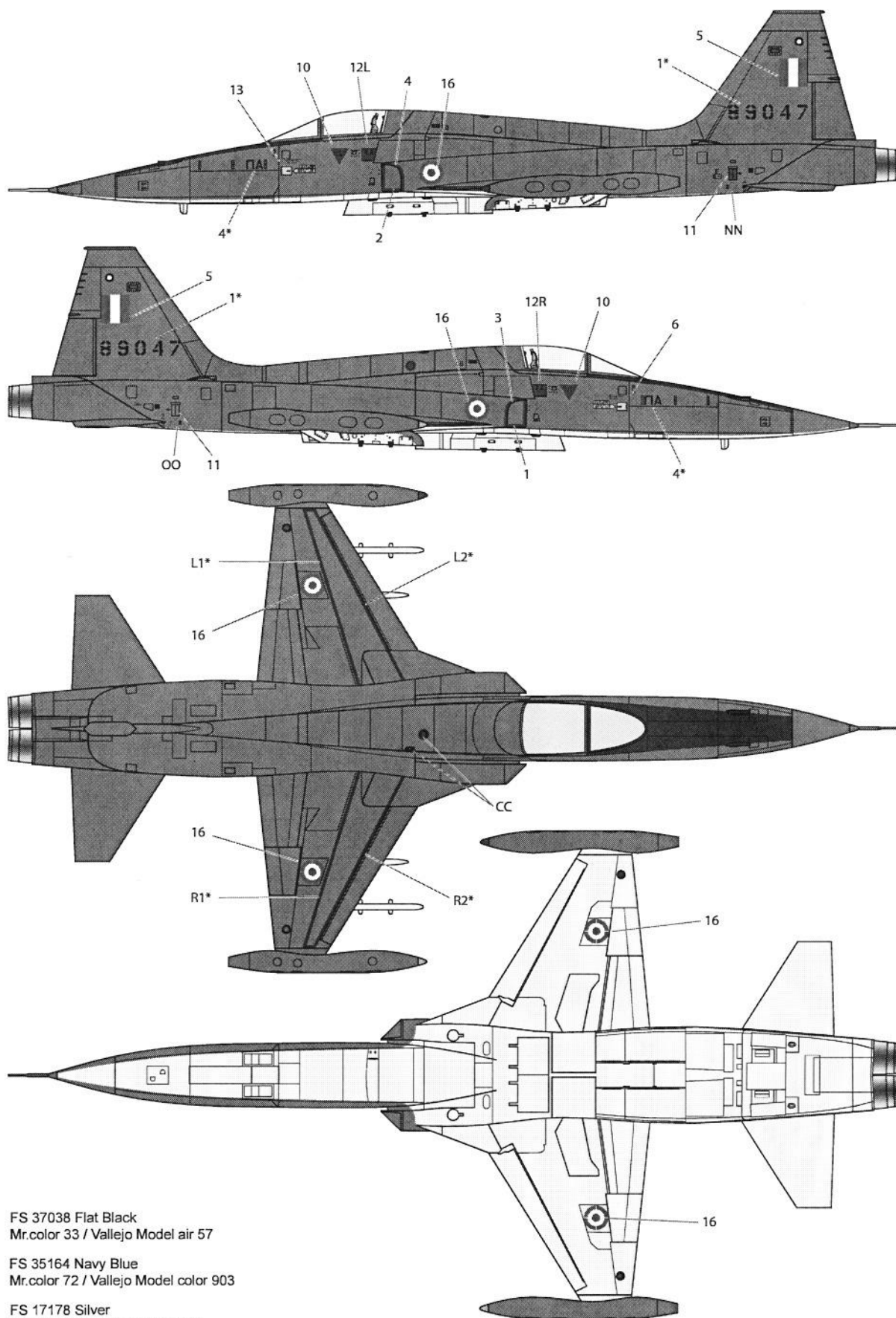

13. Greek Air Force F-5A, 341st "Arrow" Squadron, 1993.

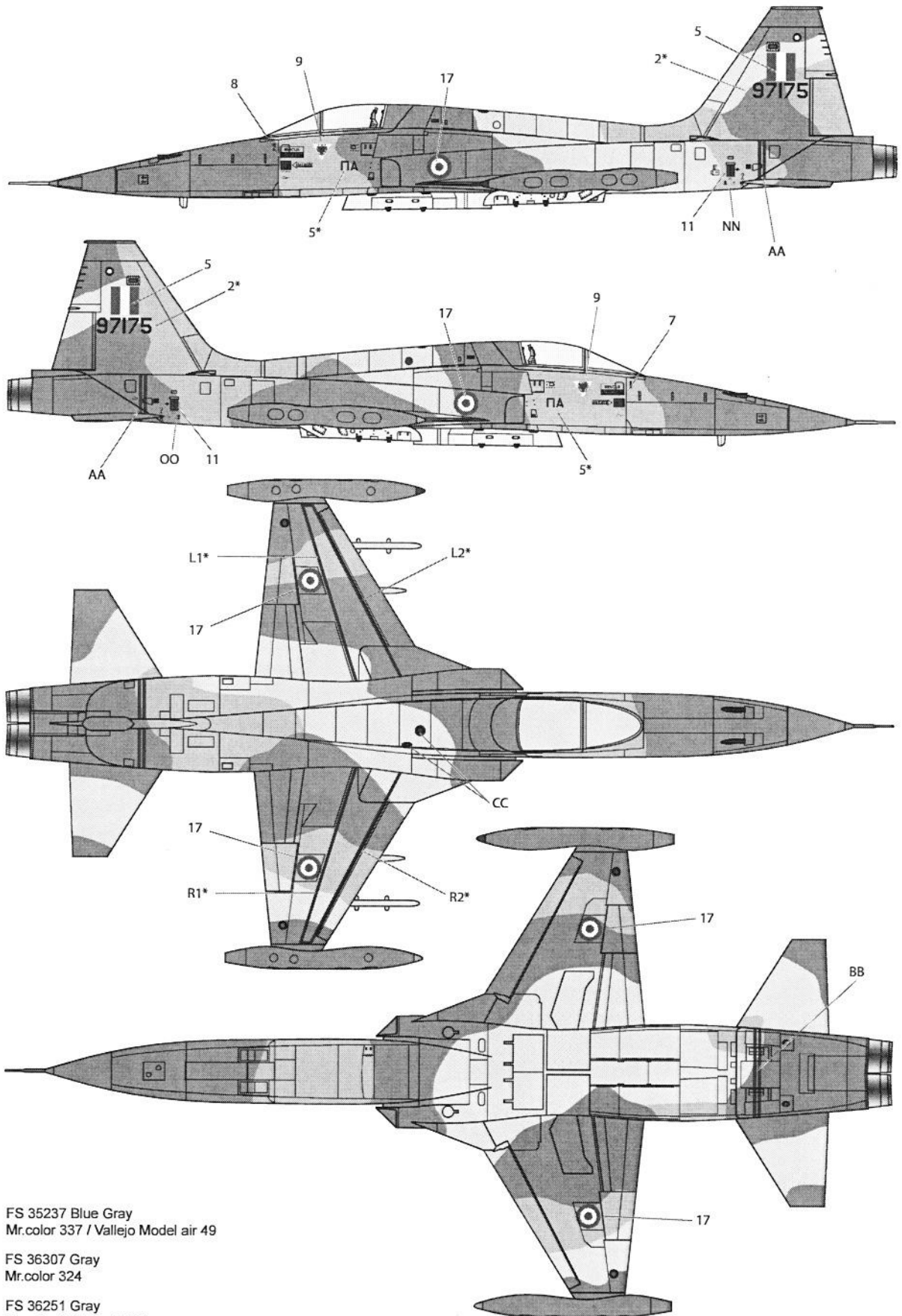

- FS 35237 Blue Gray
Mr.color 337 / Vallejo Model air 49
- FS 36307 Gray
Mr.color 324
- FS 36251 Gray
Mr.color 1*317 + 1*334

14. Greek Air Force NF-5A, 349th "Kronos" Squadron, 1993.

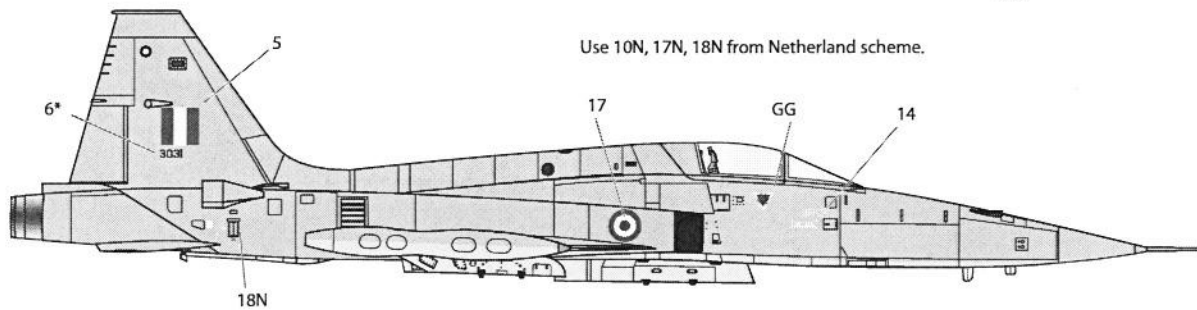
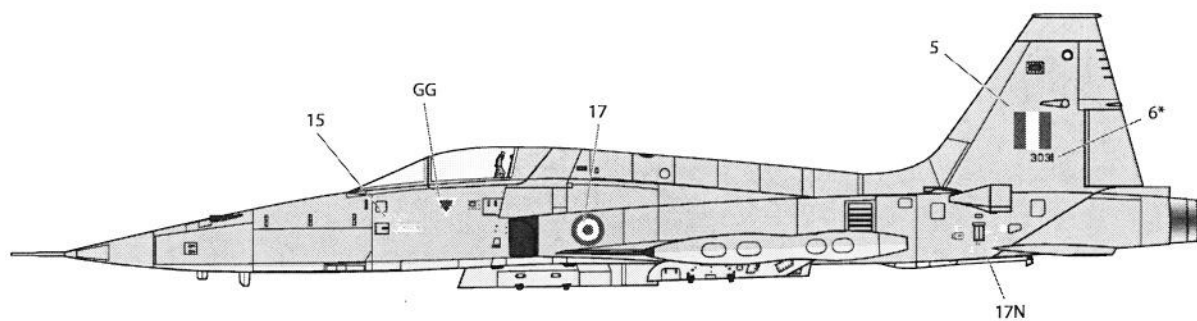

Use 10N, 17N, 18N from Netherland scheme.

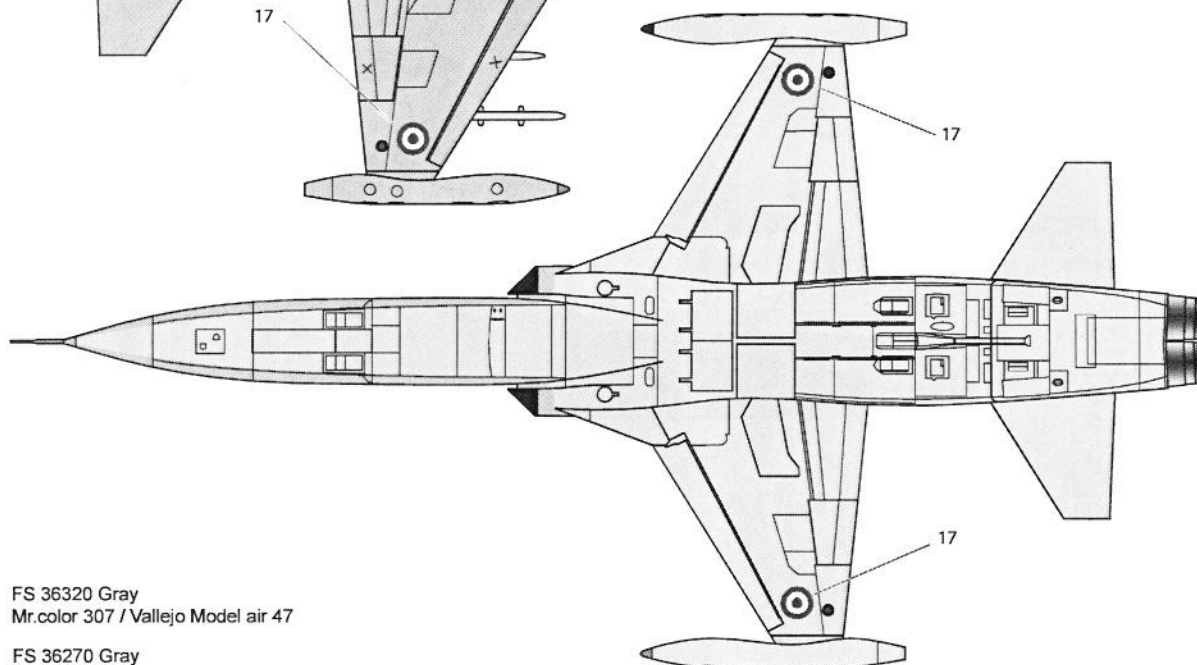
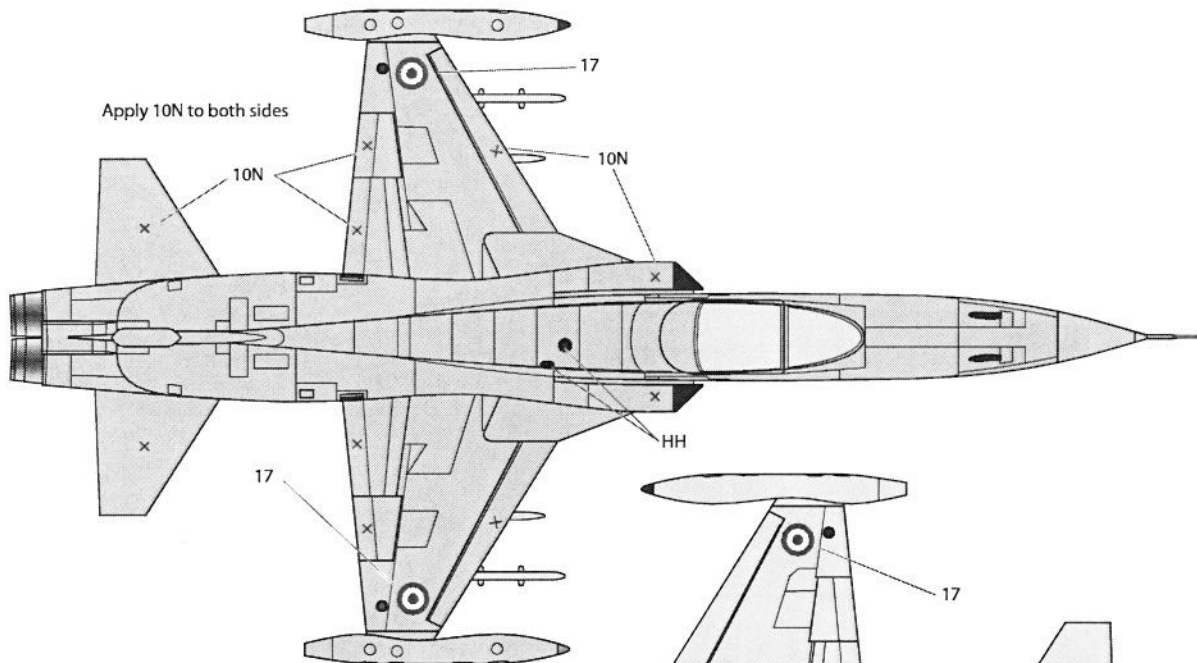

- FS 36320 Gray
 Mr.color 307 / Vallejo Model air 47
- FS 36270 Gray
 Mr.color 306 / Vallejo Model air 48

15. Greek Air Force NF-5A, 343rd "Star" Squadron, 1998.

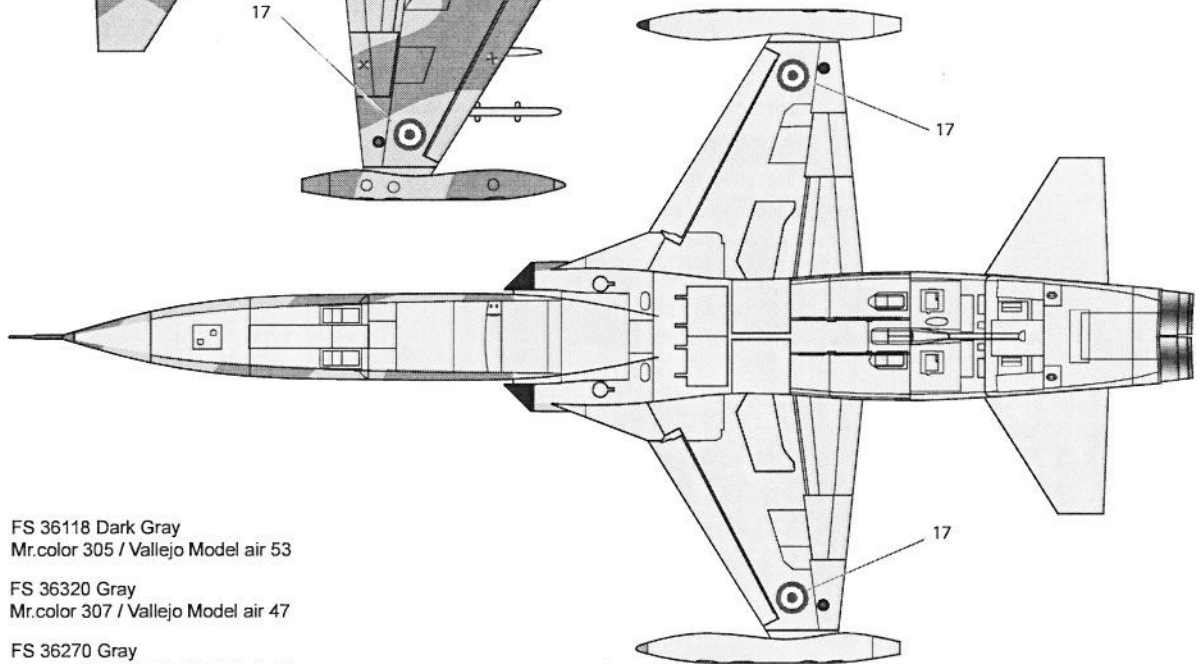
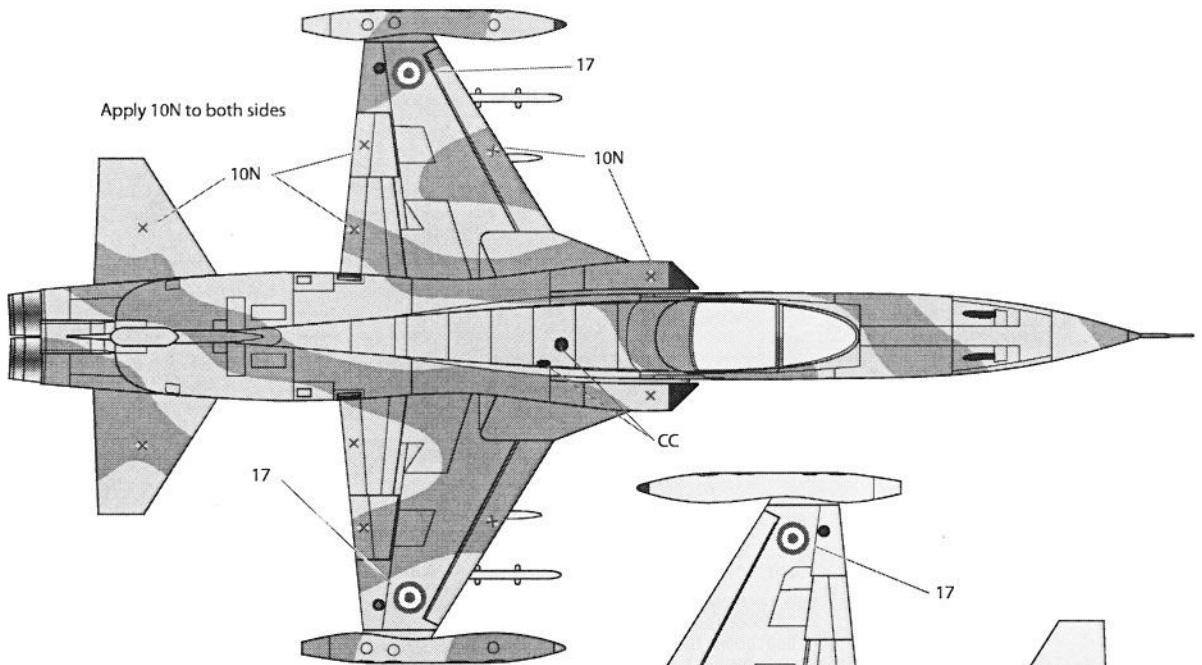
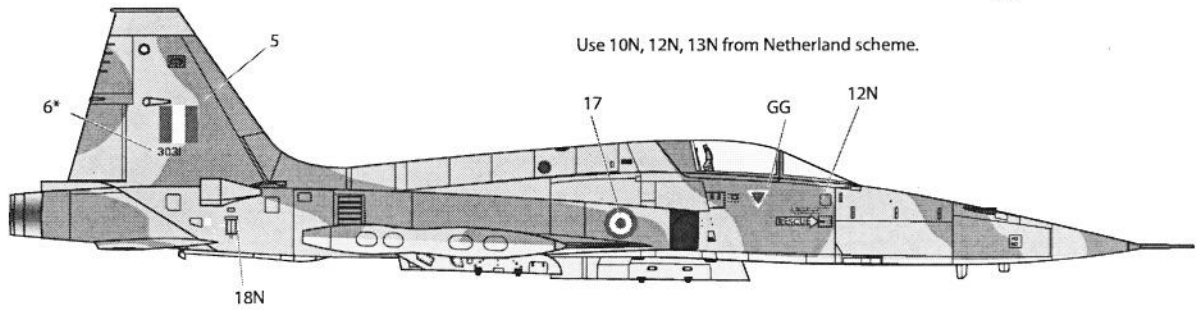
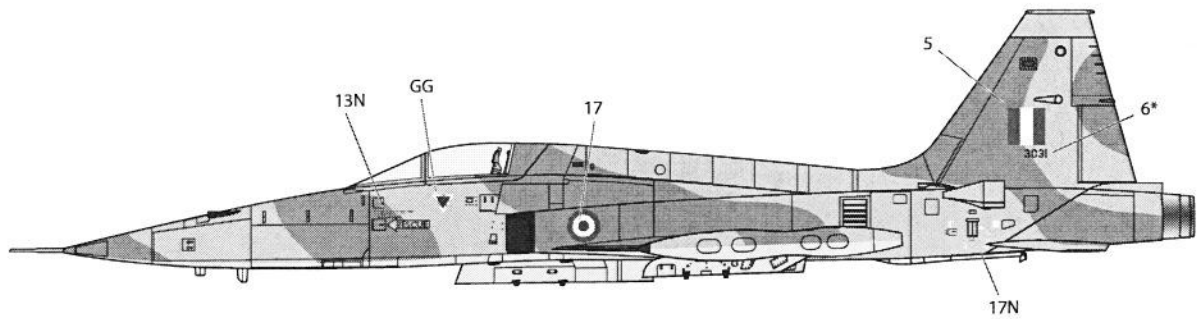

- FS 36118 Dark Gray
Mr.color 305 / Vallejo Model air 53
- FS 36320 Gray
Mr.color 307 / Vallejo Model air 47
- FS 36270 Gray
Mr.color 306 / Vallejo Model air 48

16. South Vietnamese Air Force, 23rd Wing, 522nd Sq, 1969.

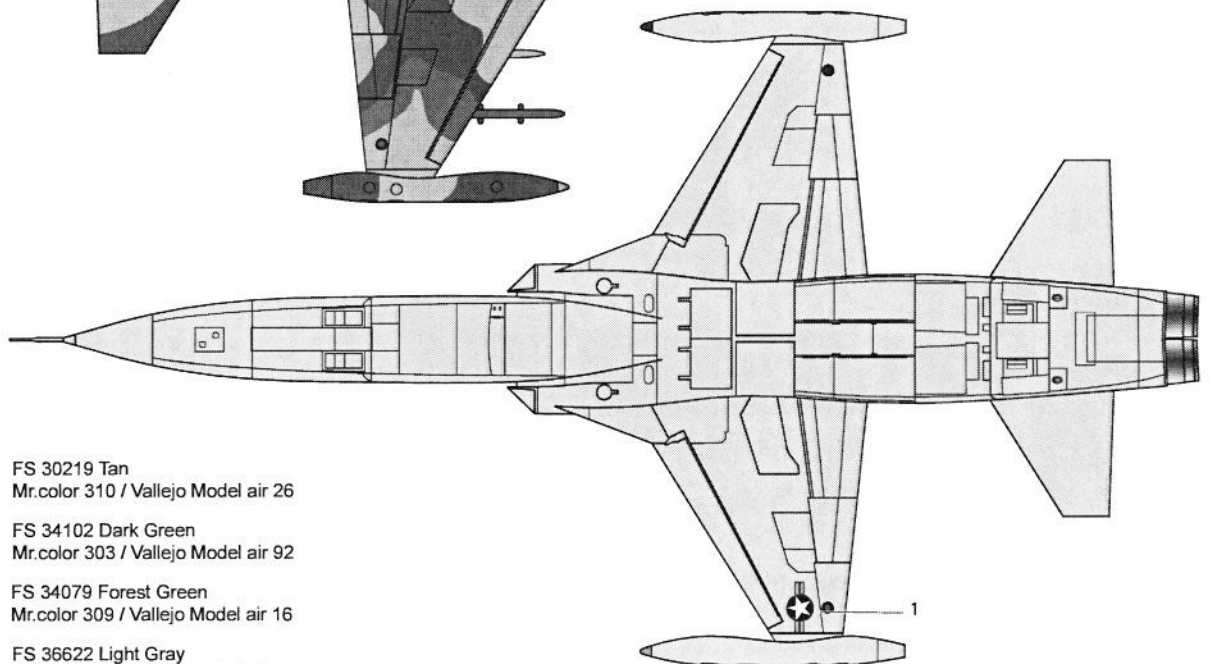
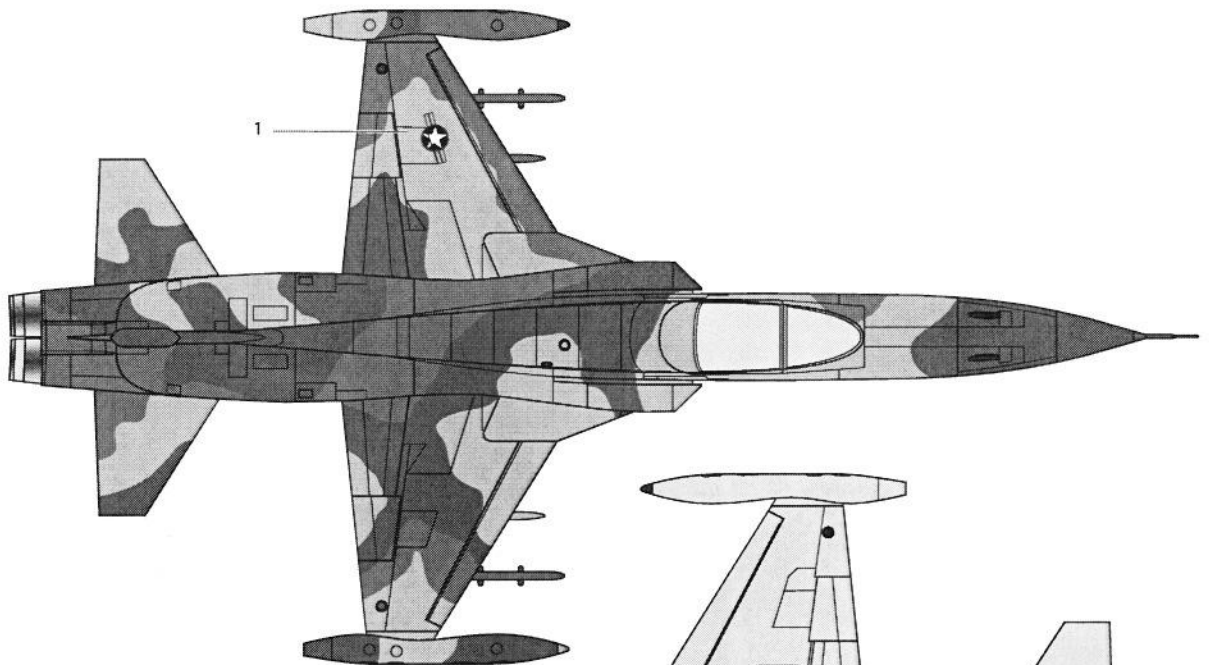
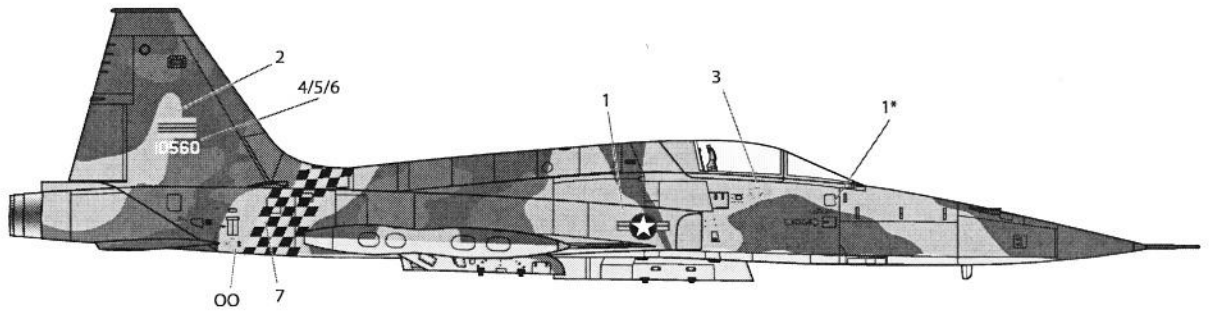
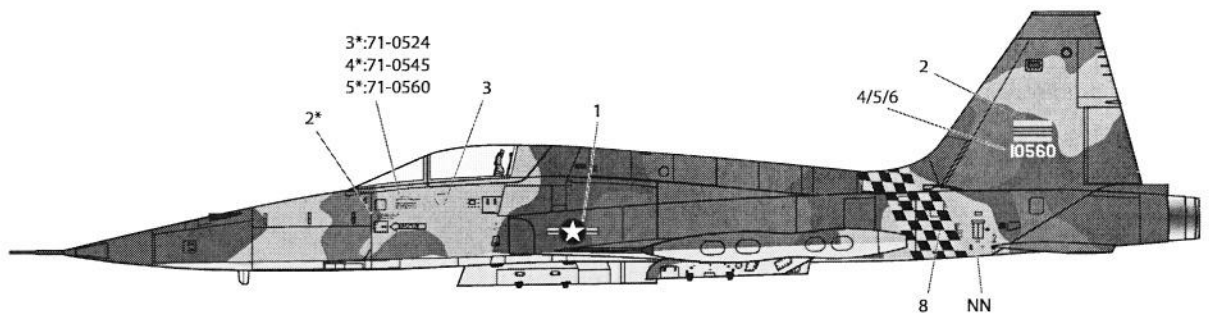

-  FS 30219 Tan
Mr.color 310 / Vallejo Model air 26
-  FS 34102 Dark Green
Mr.color 303 / Vallejo Model air 92
-  FS 34079 Forest Green
Mr.color 309 / Vallejo Model air 16
-  FS 36622 Light Gray
Mr.color 311 / Vallejo Model air 45