

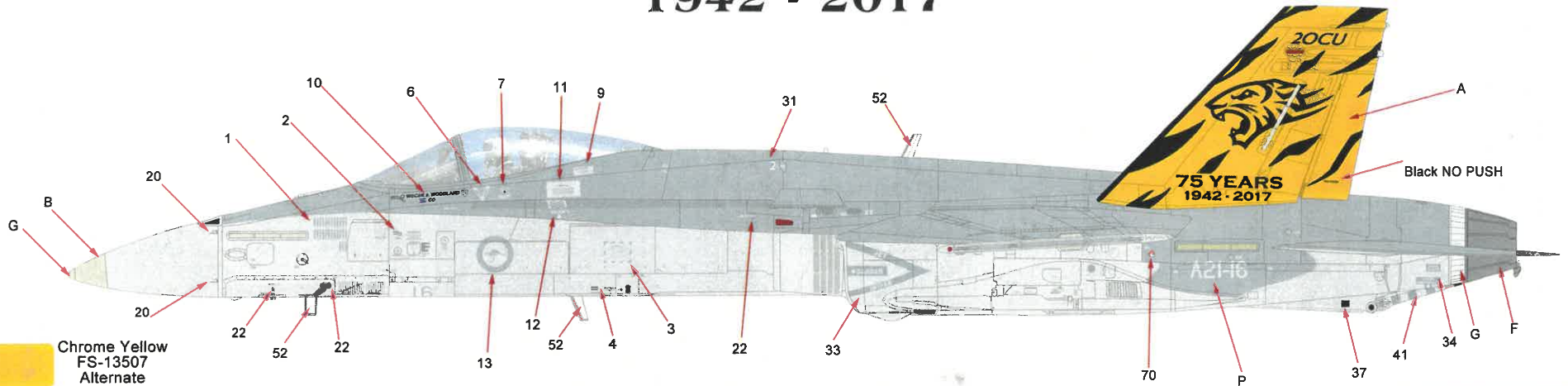

Royal Australian Air Force 2 OCU 75th Anniversary Hornet 1942 - 2017

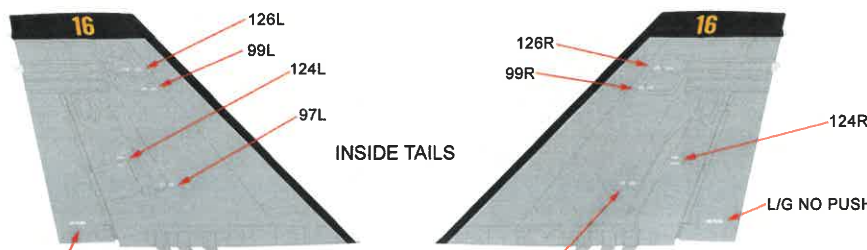

- A** Chrome Yellow
FS-13507
Alternate
FS-13538
- B** Matt Linen
Hum 74
- C** Light Ghost Grey
FS-36375
- D** Medium Grey
FS-35237
- E** Matt White
- F** Steel with a
Clear Smoke
over the top
- G** Polished
Steel



NOTE
Corrected 1/48 RAAF F/A-18 Hornet Tails
available for Hasegawa and Kinetic kits
RCS-018

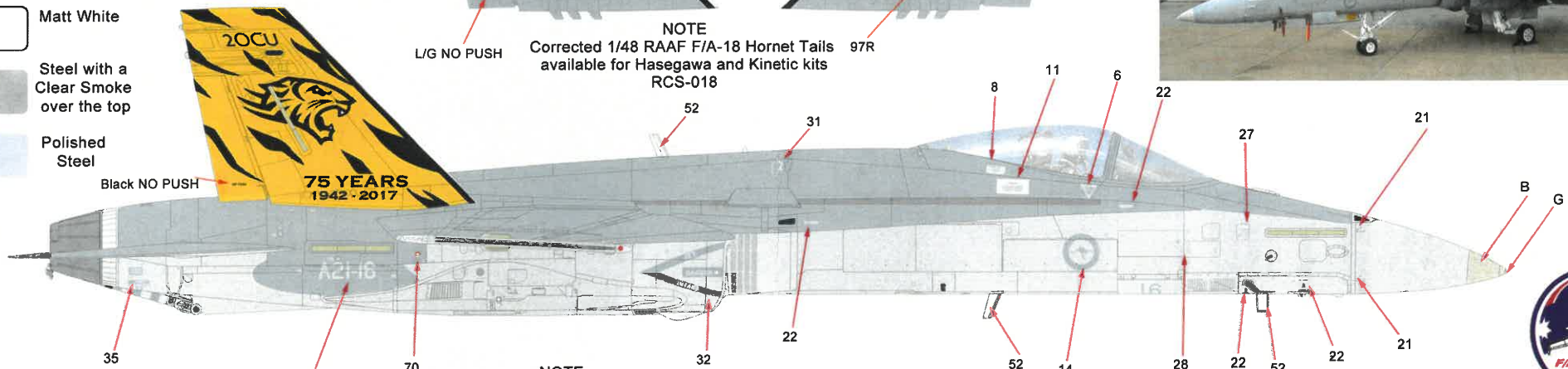

NOTE
For all other data and panel number placements
see larger Data and panel number Ins sheets



All Drawings are COPYRIGHT © 2017
PRINTED AND DESIGNED BY:
RONNIE GRAPAGIS AUSTRALIA
AUSTRALIAN MADE AND OWNED

TOP VIEW PAINT PLAN



- A  Chrome Yellow
FS-13507
Alternate
FS-13538
- B  Matt Linen
Hum 74
- C  Light Ghost Grey
FS-36375
- D  Medium Grey
FS-35237
- E  Matt White
- F  Steel with a
Clear Smoke
over the top
- G  Polished
Steel

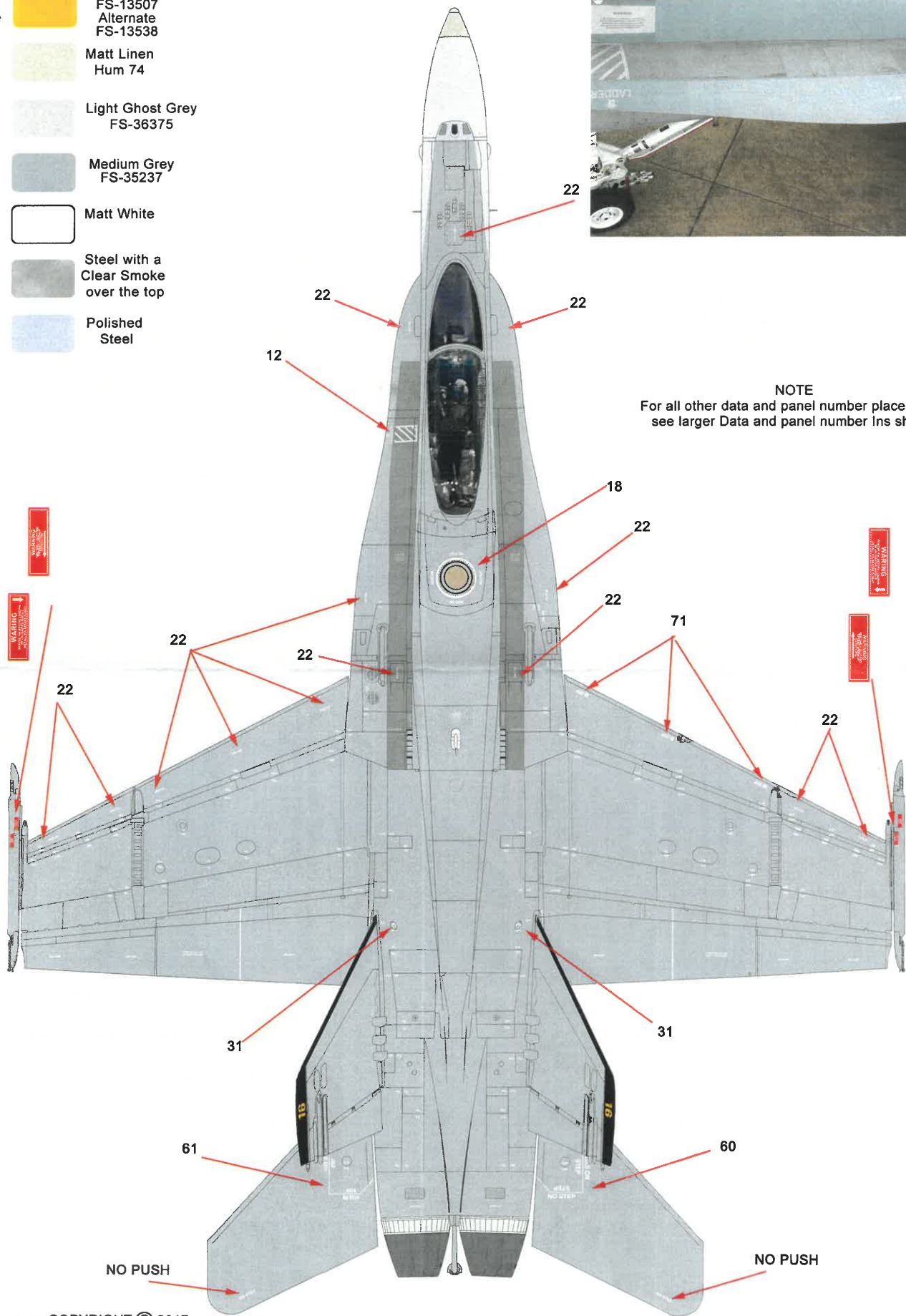

NOTE
For all other data and panel number placements
see larger Data and panel number Ins sheets

All Drawings are COPYRIGHT © 2017
PRINTED AND DESIGNED BY:
ROBIN GRAPPA'S AUSTRALIA
AUSTRALIAN MADE AND OWNED

RDS-160 RAAF 2 OCU 75TH Anniversary Hornet 1942 - 2017



- A  Chrome Yellow
FS-13507
Alternate
FS-13538
- B  Matt Linen
Hum 74
- C  Light Ghost Grey
FS-36375
- D  Medium Grey
FS-35237
- E  Matt White
- F  Steel with a
Clear Smoke
over the top
- G  Polished
Steel

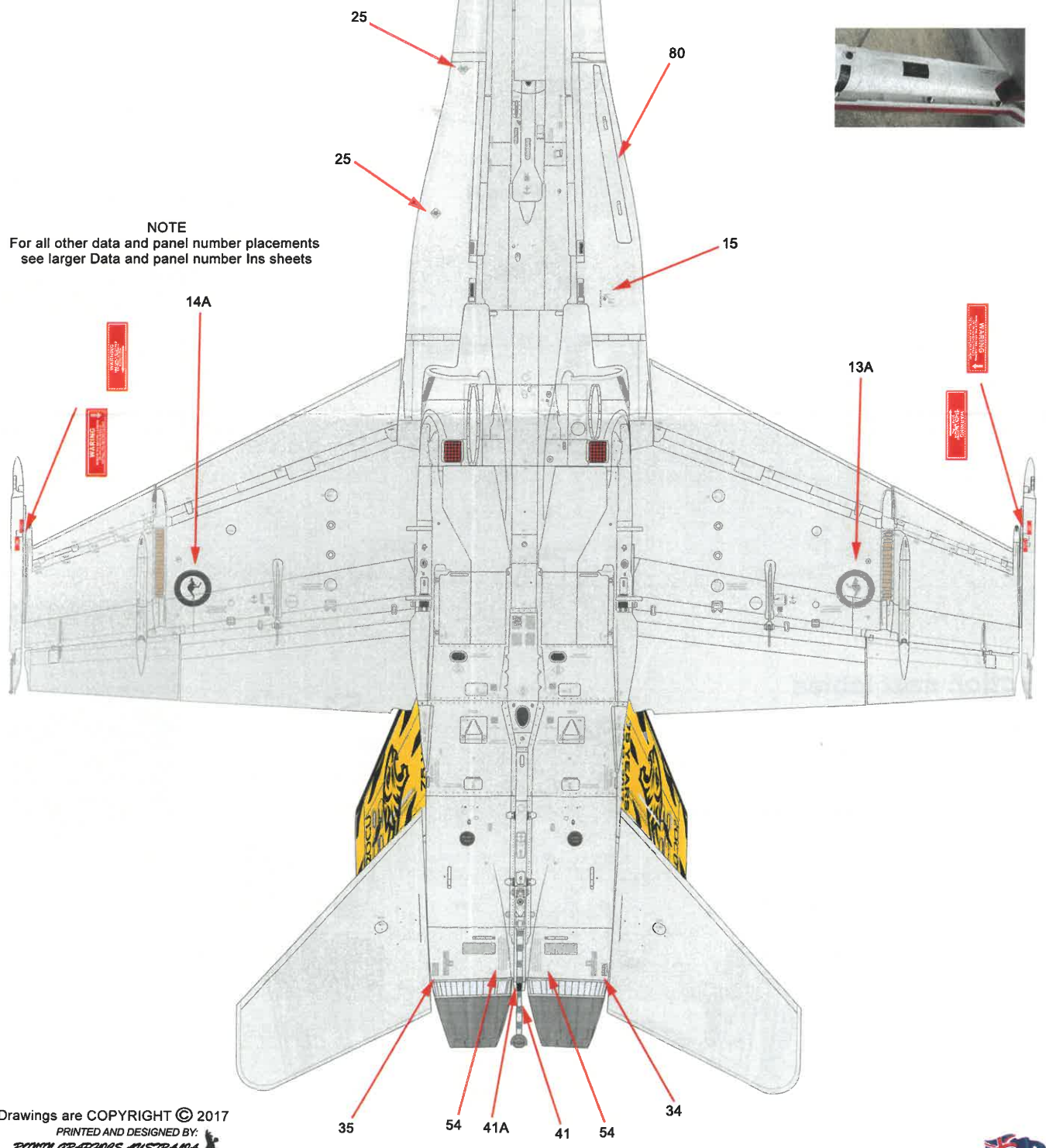
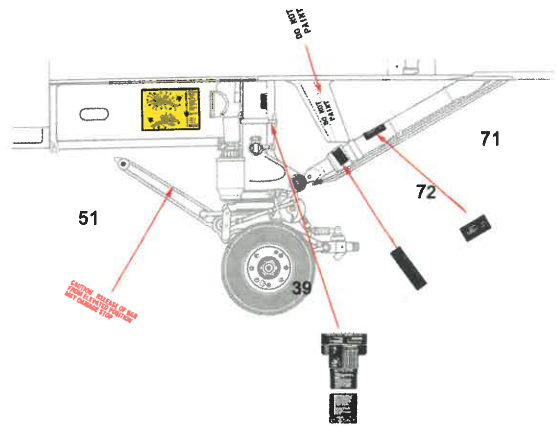

NOTE
For all other data and panel number placements
see larger Data and panel number Ins sheets

All Drawings are COPYRIGHT © 2017
PRINTED AND DESIGNED BY:
ROYAL GRAPHICS AUSTRALIA
AUSTRALIAN MADE AND OWNED

RDS-160 RAAF 2 OCU 75TH Anniversary Hornet 1942 - 2017





RAAF F/A-18 A/B Hornet Weapons Pylons & External Fuel Tank Data

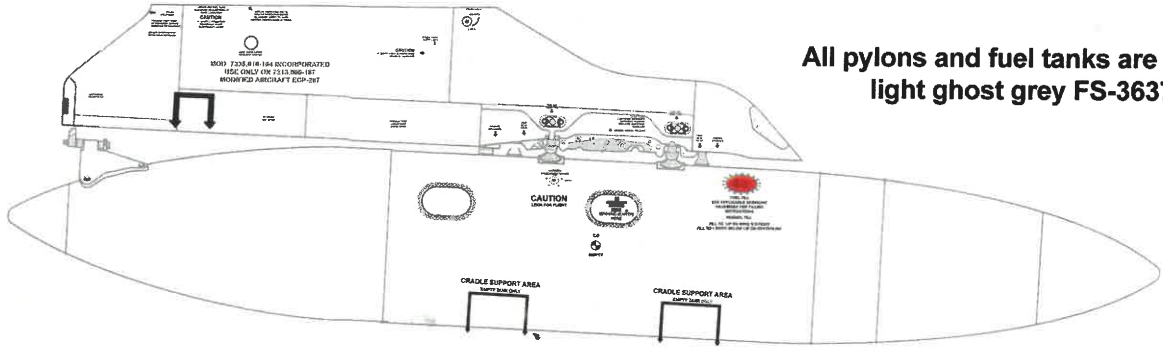
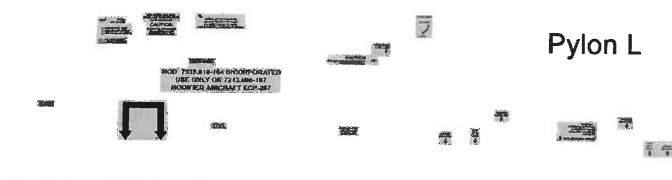
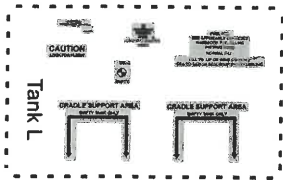

All pylons and fuel tanks are painted light ghost grey FS-36375

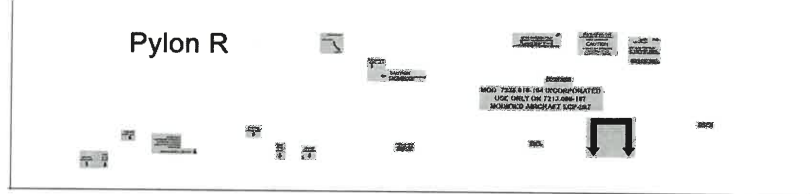
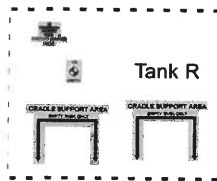

The light grey shading represents the clear decal film. You will note that the data is pre layed out in the in the positions for you.

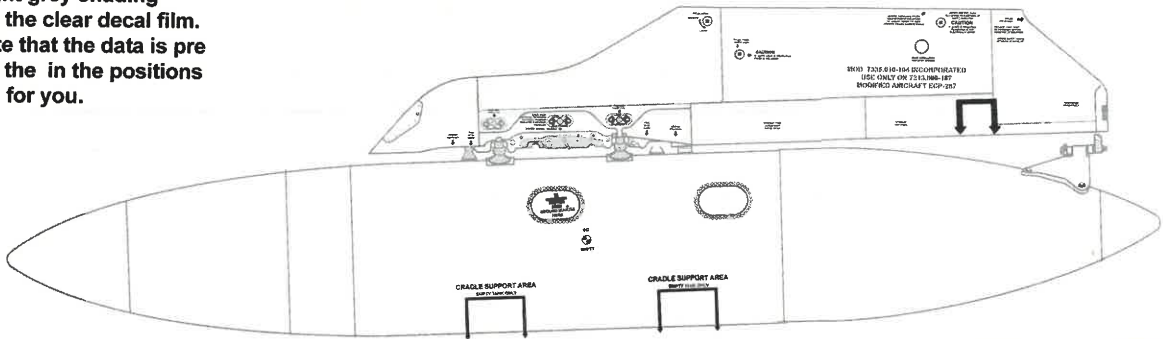

Ejection seat lables

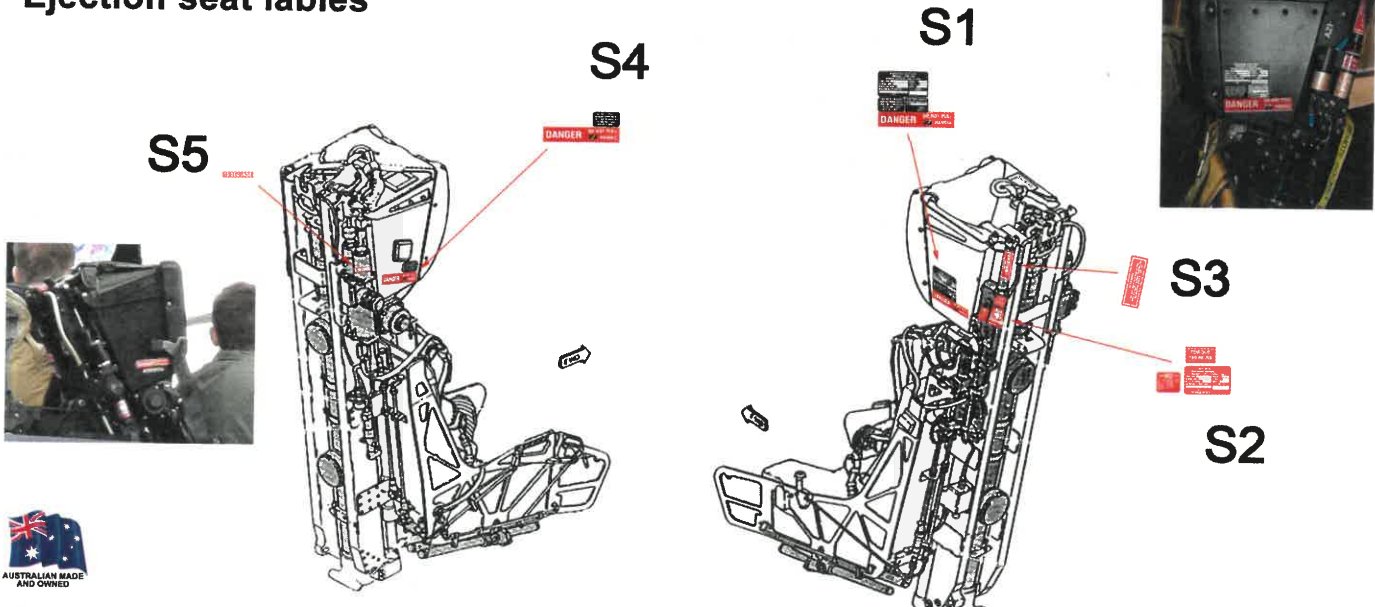

Drawing By Steven Evans

PRINTED AND DESIGNED BY:
ROMY GRAPAGS AUSTRALIA
AUSTRALIAN MADE AND OWNED



RAAF F/A-18 A/ B Hornet Panel Number Placement.

Note:
Positioning of panel numbers on decal sheet

34 35

34L 34R 35L 35R
34L 34R 35R 35R

Note:
Some aircraft have panel numbers
in slightly different positions on the panels.
As it depends on the aircraft painter.

Left

Right

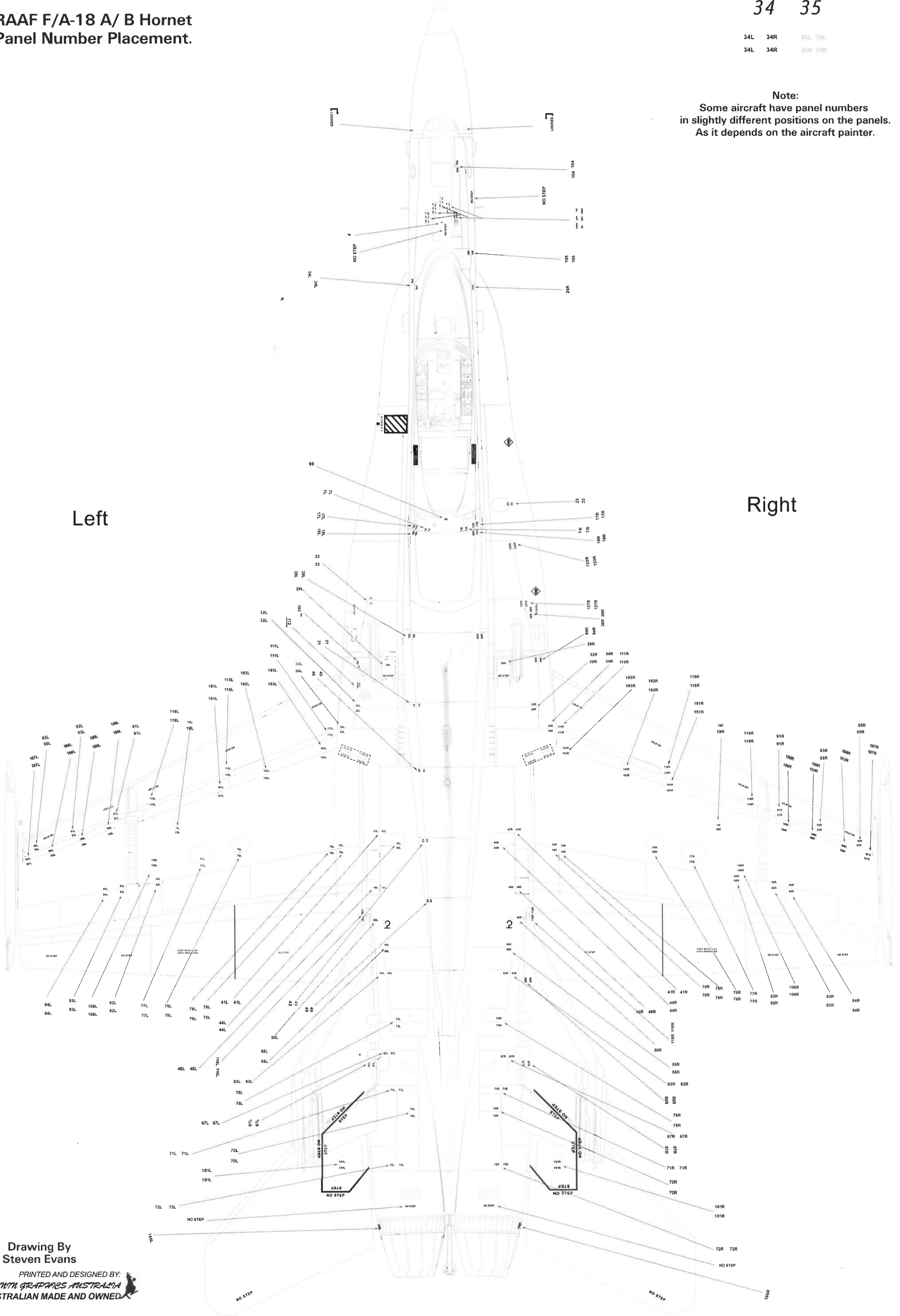

Drawing By
Steven Evans
PRINTED AND DESIGNED BY:
RONIN GRAPHICS AUSTRALIA
AUSTRALIAN MADE AND OWNED



RAAF F/A-18 A/ B Hornet Panel Number Placement.

Bottom View

Panel numbers between intake lip and fuse barrel

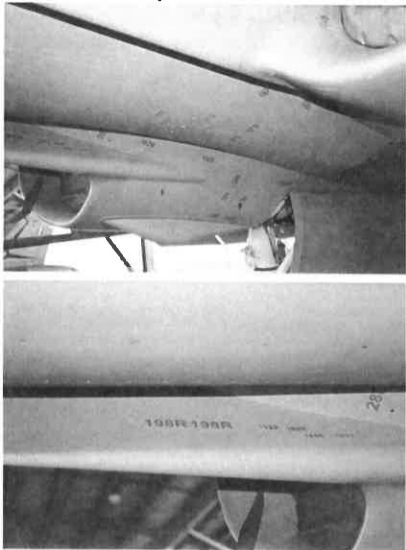

Note:
Positioning of panel numbers on decal sheet

34 35

34L 34R 35L 35R
34L 34R 35R 35L

Note:
Some aircraft have panel numbers in slightly different positions on the panels. As it depends on the aircraft painter.

Panel numbers between intake lip and fuse barrel

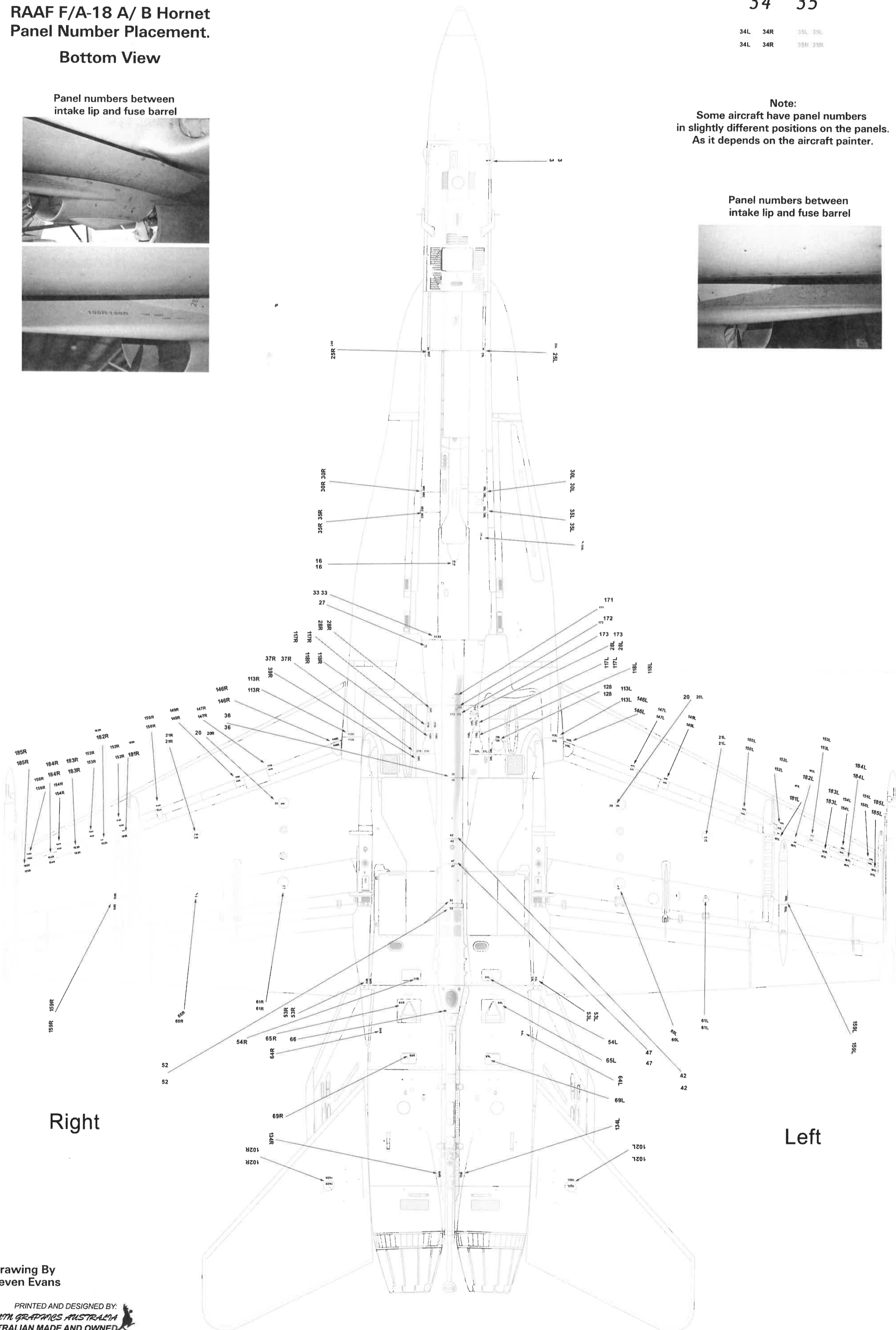

Right

Left

Drawing By
Steven Evans

PRINTED AND DESIGNED BY:
RONIN GRAPHICS AUSTRALIA
AUSTRALIAN MADE AND OWNED

Drawn by: RONIN GRAPHICS © Copyright 2012

1/48 RAAF Hornet Panel Numbers Printed by **WETA** 2017-09-10

1	4	6	7	8	9	10	11	12	13	14	15	16
17	18	19	20	21	22	23	24	25	26	27	28	29
30	31	32	33	34	35	36	37	38	39	40	41	42
43	44	45	46	47	48	49	50	51	52	53	54	55
56	57	58	59	60	61	62	63	64	65	66	67	68
69	70	71	72	73	74	75	76	77	78	79	80	81
82	83	84	85	86	87	88	89	90	91	92	93	94
95	96	97	98	99	100	101	102	103	104	105	106	107
108	109	110	111	112	113	114	115	116	117	118	119	120
121	122	123	124	125	126	127	128	129	130	131	132	133
134	135	136	137	138	139	140	141	142	143	144	145	146
147	148	149	150	151	152	153	154	155	156	157	158	159
160	161	162	163	164	165	166	167	168	169	170	171	172
173	174	175	176	177	178	179	180	181	182	183	184	185
186	187	188	189	190	191	192	193	194	195	196	197	198

16 16 16 16

16 16 A21-16 S
A21-16 P

80
16

20CU 20CU

75 YEARS 1942-2017 75 YEARS 1942-2017

20CU 20CU

75 YEARS 1942-2017 75 YEARS 1942-2017

12

41 13 14 14A 13A 54 25 18

61 41A 60 49 52 22 22 22 71

PRINTED AND DESIGNED BY
WETA WORKS AUSTRALIA
AUSTRALIAN MADE AND OWNED

**1/48 RDS-160
20CU 75TH ANNIVERSARY F/A-18A+ HORNET 1917-2017**

WETA

Pylon L Pylon R

Tank R

Pylon L Pylon R

Pylon L Pylon R

Pylon L Pylon R

Pylon L Pylon R

Pylon L Pylon R