



1/72 SCALE MODEL CONSTRUCTION KIT

A03082

NORTH AMERICAN F-86F™/E(M) SABRE

GB The F86 Sabre has rightly come to be regarded as one of the most outstanding aviation designs of all time. Serving with air forces across the globe for over forty years, the Sabre was designed in an era of guns and served into the missile age.

It was in the skies over Korea that the Sabre forged its reputation, amassing an amazing 10:1 kill ratio over the Communist forces. While the MiG 15 was a comparable fighter aircraft, it was the superior training and tactics of the USAF

F C'est à juste titre que le F86 Sabre est considéré comme l'un des avions les plus exceptionnels de tous les temps. En service au sein des forces aériennes mondiales depuis plus de quarante ans, le Sabre fut conçu à l'époque des canons mais vit naître l'âge des missiles.

Il établit sa réputation dans le ciel au-dessus de la Corée contre les forces communistes, atteignant un taux de victoire incroyable de 10 contre 1 en sa faveur. Même si le MiG 15 était comparable en tant que chasseur, ce furent l'entraînement

D Die F86 Sabre wird heute berechtigterweise als eine der erfolgreichsten Flugzeugkonstruktionen angesehen, die es je gegeben hat. Über vierzig Jahre lang von Luftstreitkräften der ganzen Welt eingesetzt, wurde die Sabre zwar noch in einem Zeitalter von Kanonen und MGs entworfen, wurde jedoch noch bis weit in die Ära ferngelenkter Raketen hinein eingesetzt.

Über Nordkorea erkämpfte sich die Sabre vor allem ihren Ruf, wo sie ein bis dahin unvorstellbares Abschussverhältnis von 1:10 über die kommunistischen Gegner erzielen konnte. Während die MiG 15 zwar ein sonst durchaus vergleichbares Kampfflugzeug war, konnten die Piloten der USAF vor

E El F86 Sabre ha sido considerado con toda justicia uno de los diseños más excepcionales de la aviación de todos los tiempos. Fue utilizado por distintas fuerzas aéreas de todo el mundo durante más de cuarenta años y su diseño, en la era de los cañones, pervivió hasta la de los misiles.

El Sabre se forjó su reputación en los cielos de Corea, logrando una impresionante ratio de derribos de 10:1 sobre las fuerzas comunistas. Aunque el MiG 15 era un caza de prestaciones similares, la formación y preparación táctica de los pilotos de

S F86 Sabre har med rätta blivit erkänt som en av tidernas mest imponerande flygplansdesigner. Sabre, som användes av flera flygvapen över hela världen i över 40 år, ritades i "vapen-eran" och tjänstgjorde ända in i "missil-åldern".

Det var i luftrummet över Korea som Sabre grundmurade sitt rykte mot bakgrund av en fenomenal nedskjutningskvot på 10:1 mot de kommunistiska styrkorna. MiG 15 var visserligen ett jämförbart jaktplan, men i det fallet var det de

pilots that enabled them to overcome the enemy forces.

The F-86F introduced the larger "6-3" wing without leading edge slats and also had the capability to be equipped with bombs, turning the Sabre into a capable ground attack fighter, a mission it was able to perform admirably over Korea.

Armament: 6 x .50cal Machine guns; length: 11.4m; wingspan: 11.3m; max speed: 687mph.

et la tactique supérieurs des pilotes américains qui leur permirent de vaincre l'ennemi.

Le F86F était doté d'une nouvelle aile plus grande (nommée '6-3') sans bords de bord d'attaque. Il avait la capacité d'être équipé de bombes, ce qui le convertit en chasseur d'attaque au sol performant, mission accomplie à perfection en Corée.

Armement : 6 mitrailleuses de 12,7 mm ; longueur : 11,4 m ; envergure : 11,3 m ; vitesse maximale : 1.105 km/h.

allem durch ihre unvergleichlich bessere Ausbildung ihre Widersacher überwinden.

Mit der F-86F wurden die vergrößerten Pfeilflügel („6-3“) ohne vordere Steuerflächen eingeführt. Außerdem konnte diese Version mit Bomben bestückt werden, womit sie auch als hoch leistungsfähiger Bodenangriffsjäger verwendet werden konnte – eine Einsatzweise, die das Flugzeug so überzeugend über Nordkorea vorexerzierte.

Bewaffnung: 6 Maschinenkanonen, 12,7 mm; Länge: 11,4 m; Spannweite: 11,3 m; Höchstgeschwindigkeit: 1105 km/h.

la USAF fueron decisivos para superar al enemigo.

El F-86F introdujo las alas de gran tamaño "6-3" sin rebordes delanteros y tenía capacidad para equipar bombas, que convertían al Sabre en un eficaz avión de ataque sobre tierra, misión que cumpliría de forma admirable sobre Corea.

Armamento: 6 ametralladoras de 12,7mm; longitud: 11,4m; envergadura: 11,3m; velocidad máxima: 1105Km/h.

amerikanska piloternas överlägsna träning och taktik som gav dem ett övertag över fiendestyrkorna.

F-86F introducerade den större "6-3"-vingen utan kantlister och med kapacitet att flyga med bomber, vilket förvandlade Sabre till ett kapabelt markattackerplan, en roll som planet spelade med stora framgångar över Korea.

Beväpning: 6 x 12,7 mm-kulsprutor; längd: 11,4 meter; vingspann: 11,3 meter; maximal hastighet: 1 105 km/h.

PLEASE NOTE : Some parts in the kit may not be required to build the model.

F-86 Sabre Jet™

Produced under license from Boeing Management Company.

Boeing and F-86 Sabre Jet are among the trademarks owned by Boeing.

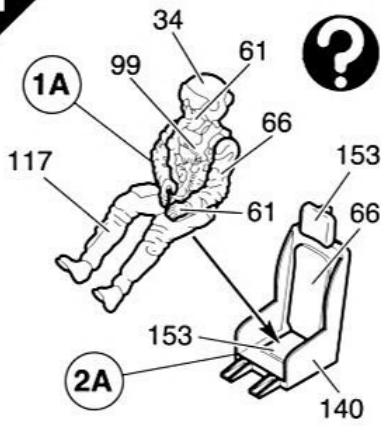
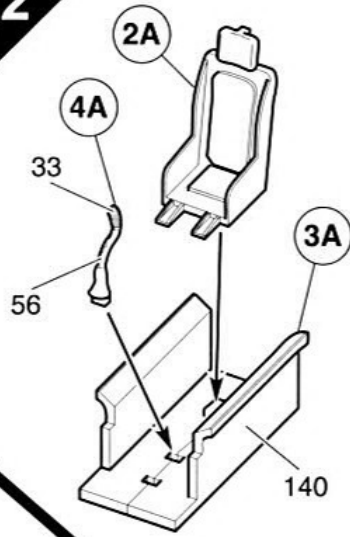
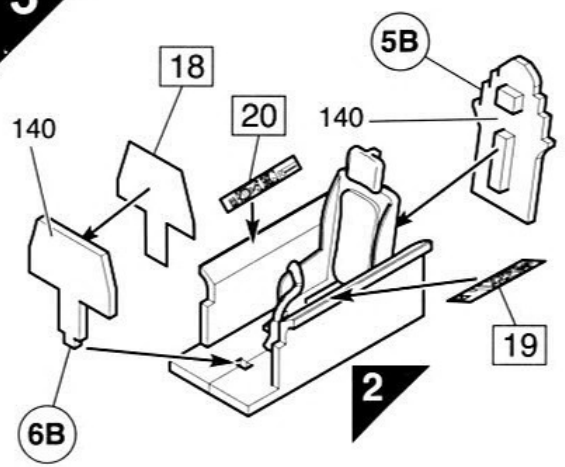
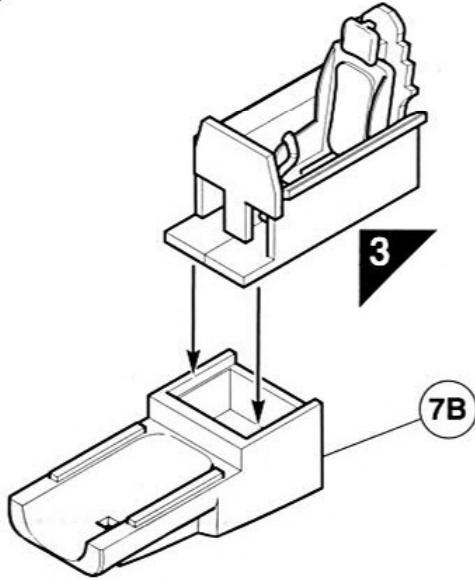
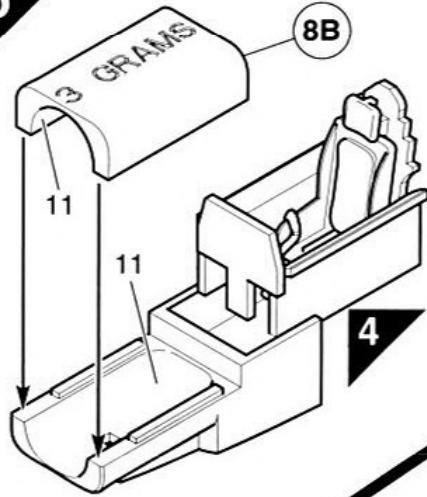
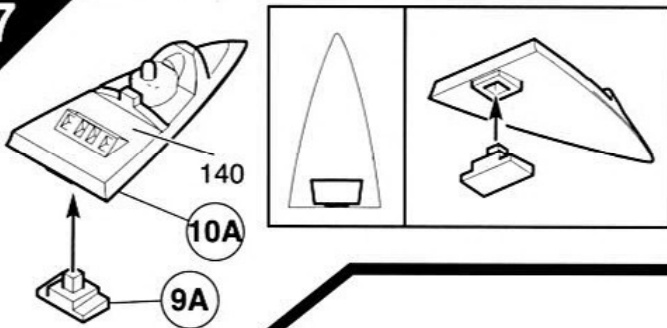
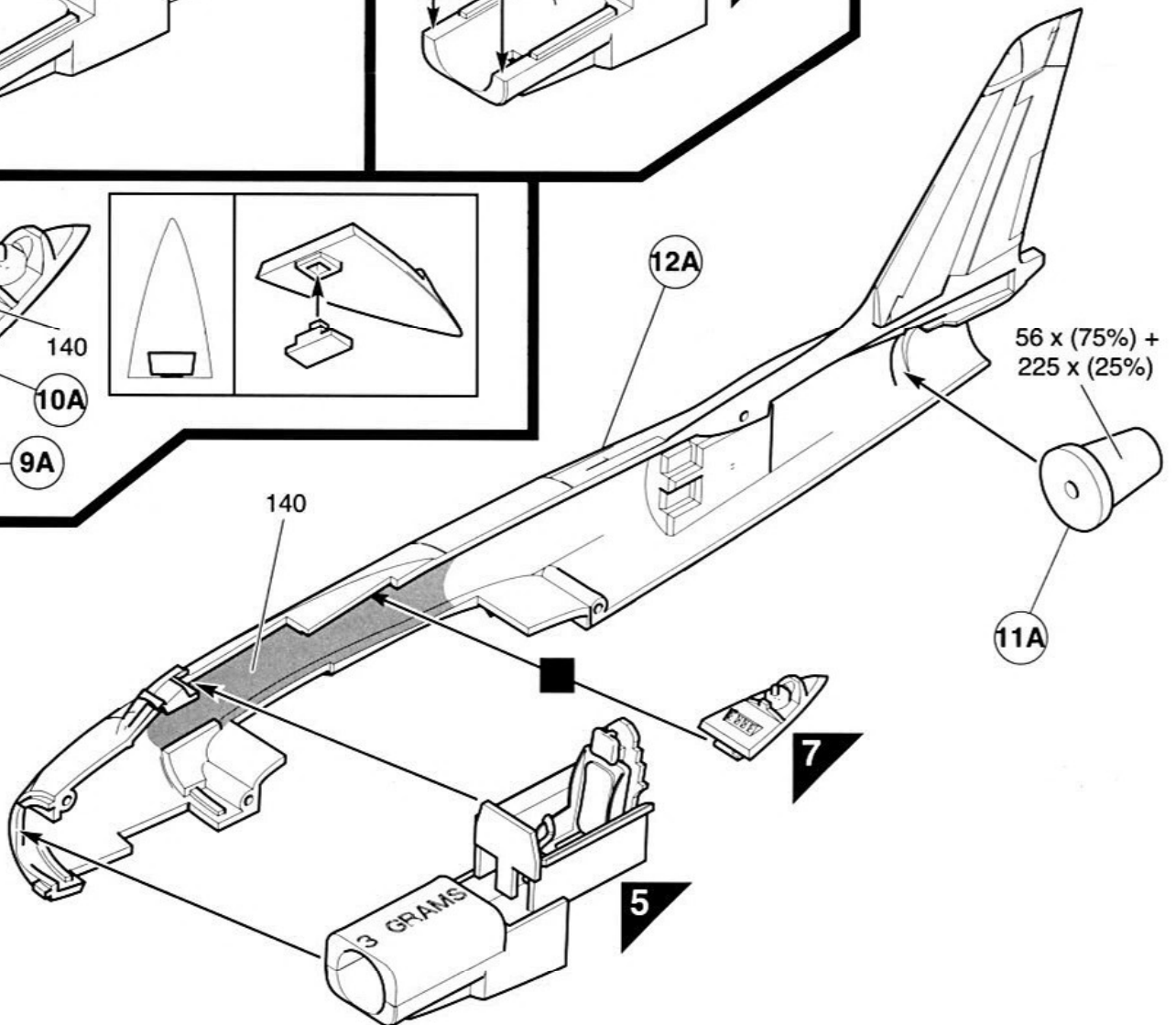
1**2****3****4****5****6****7****8**

9

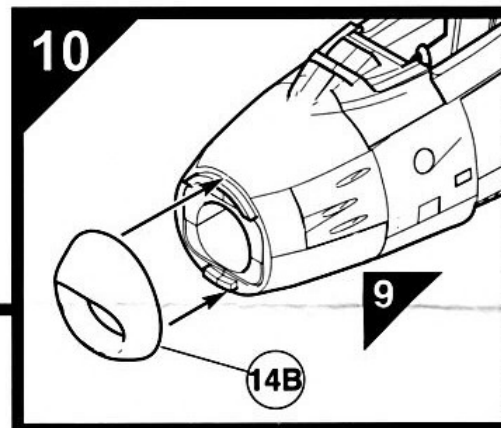
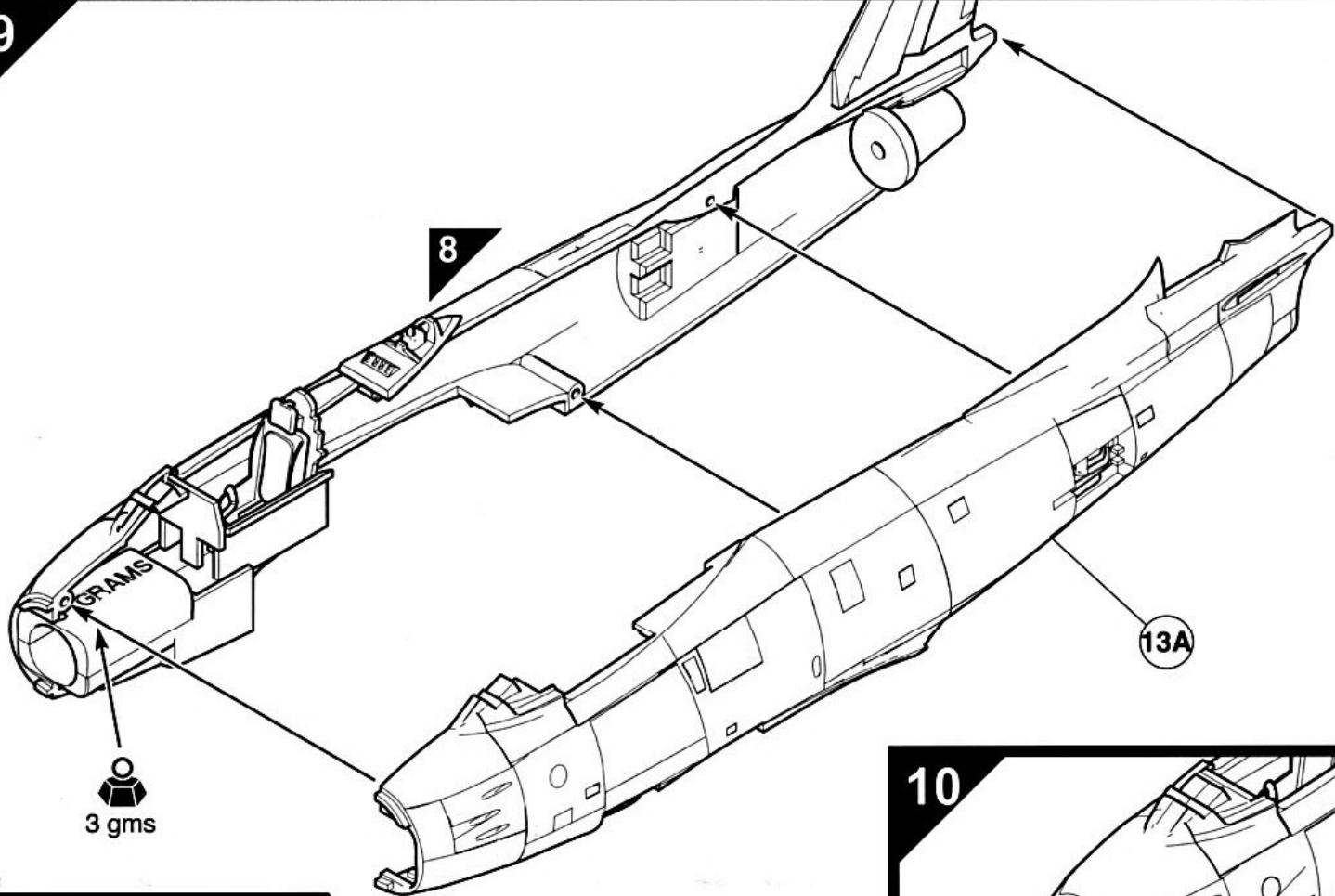

11

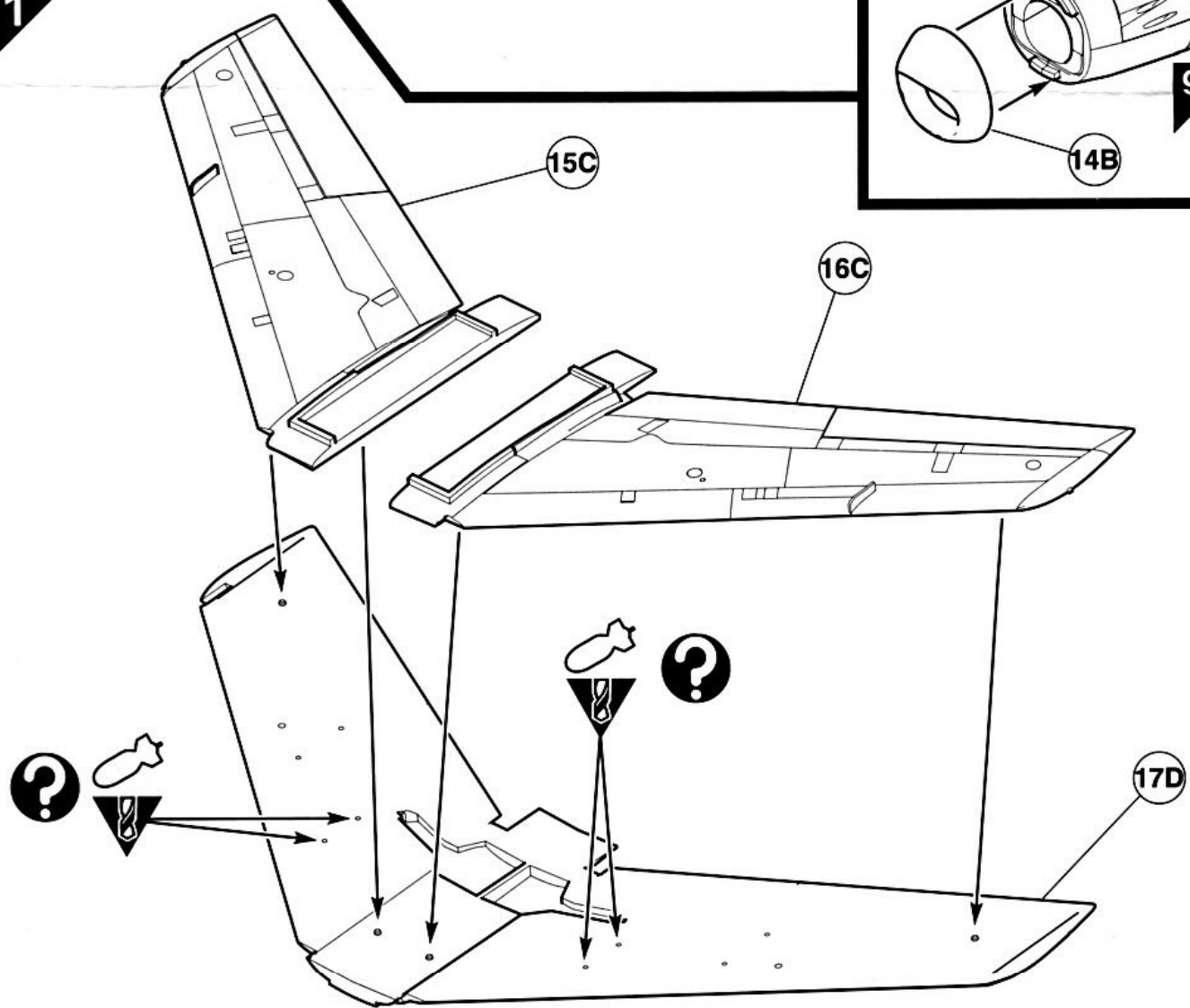

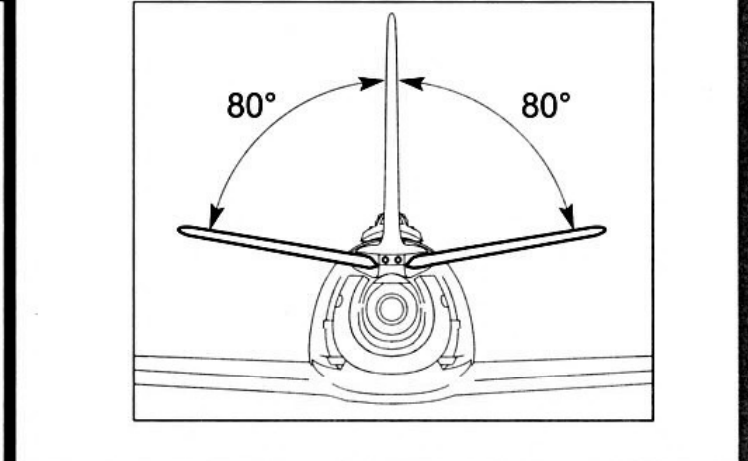
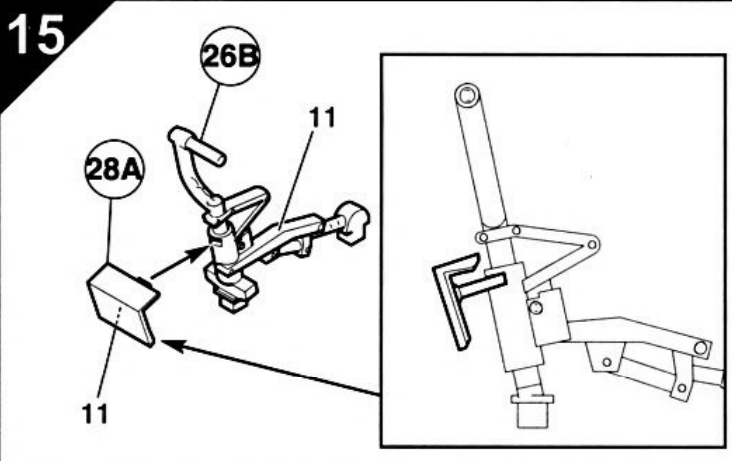
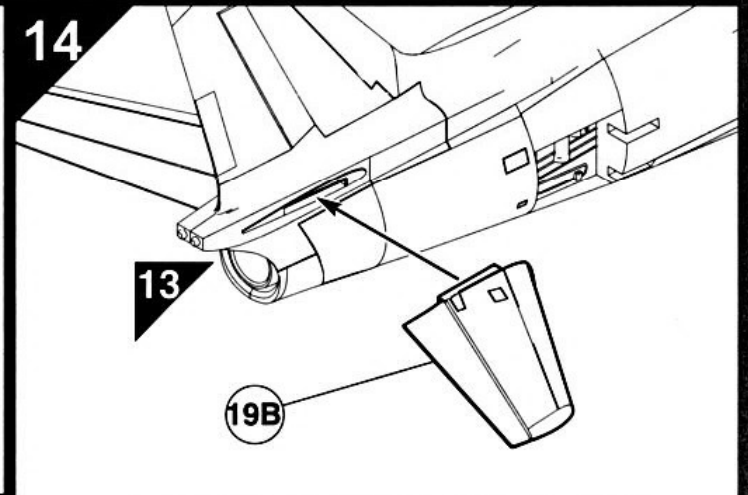
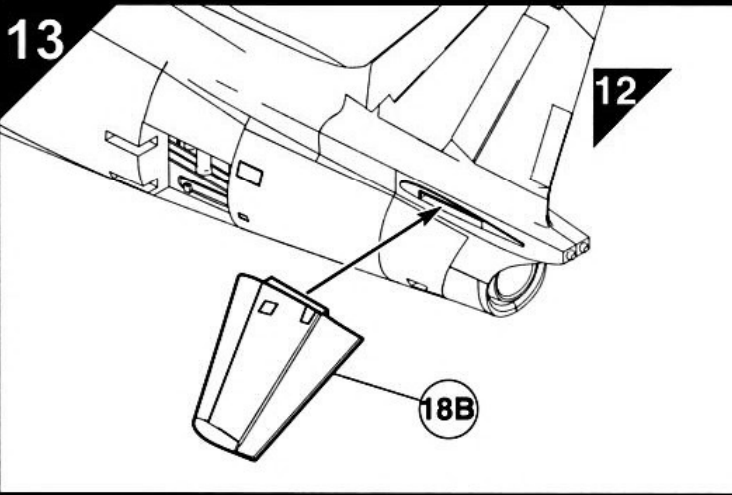
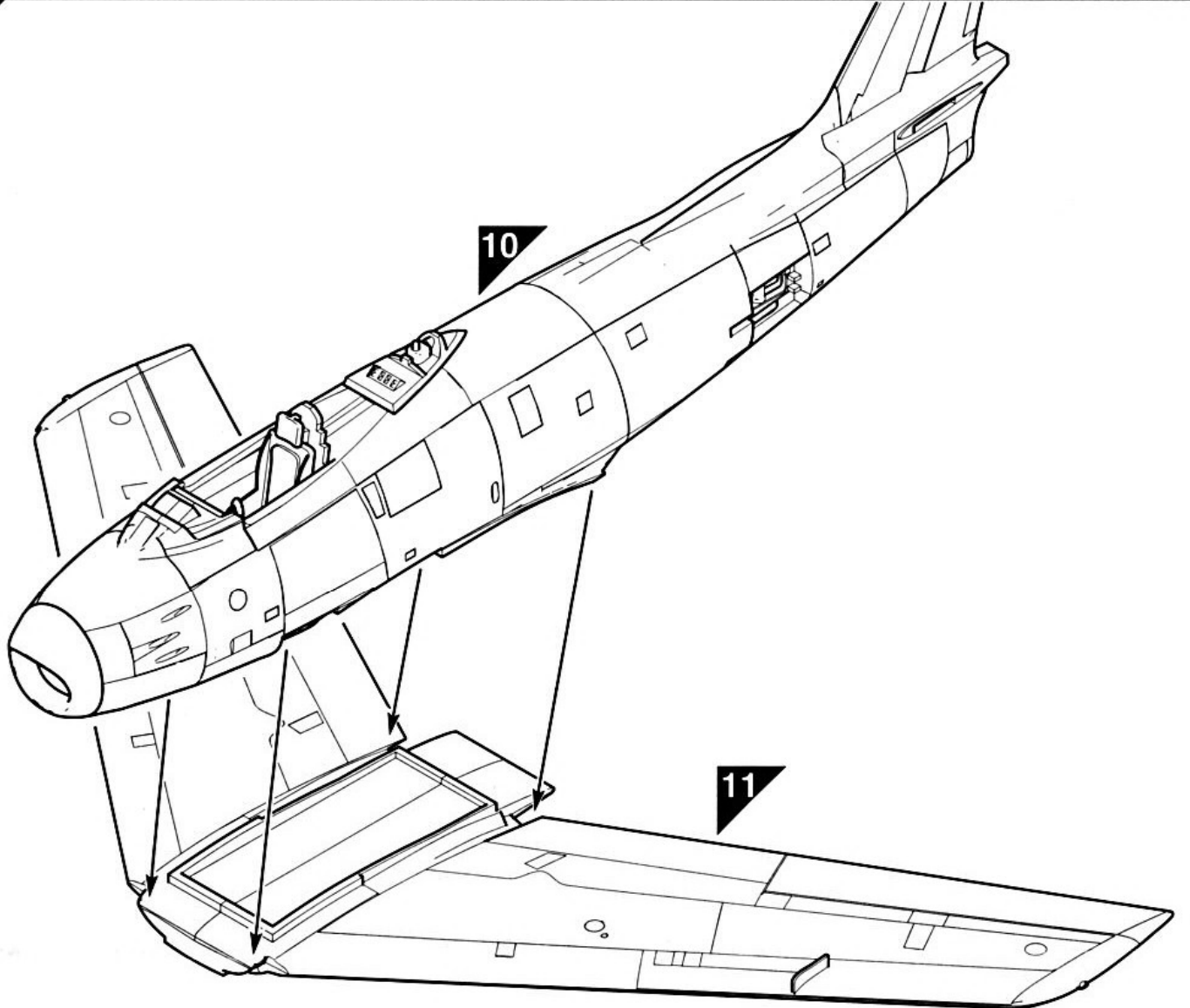

16

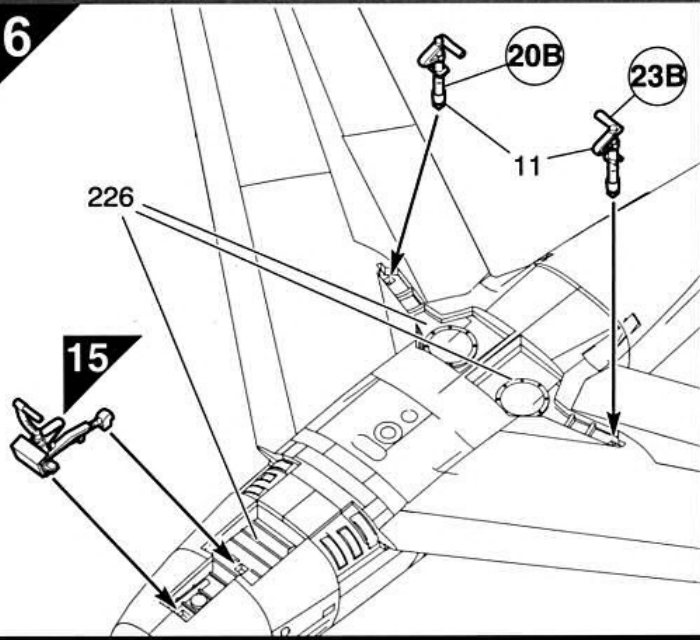

17

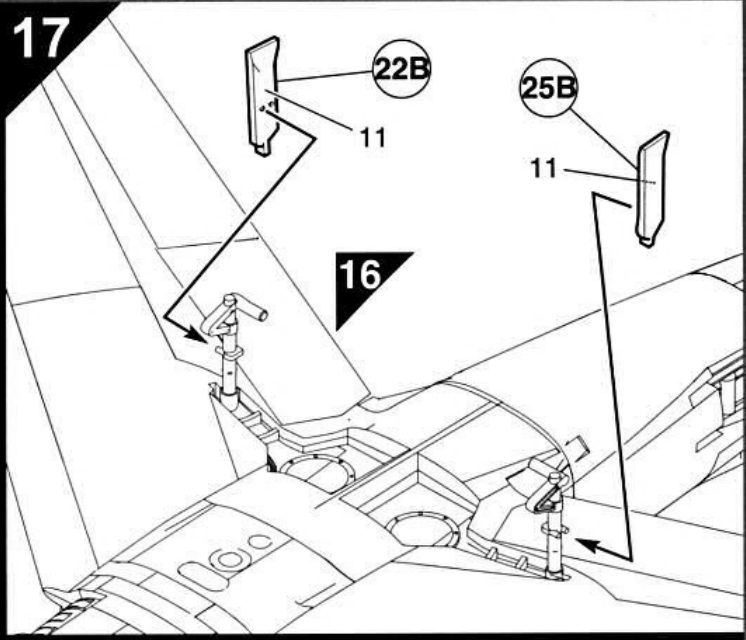

18

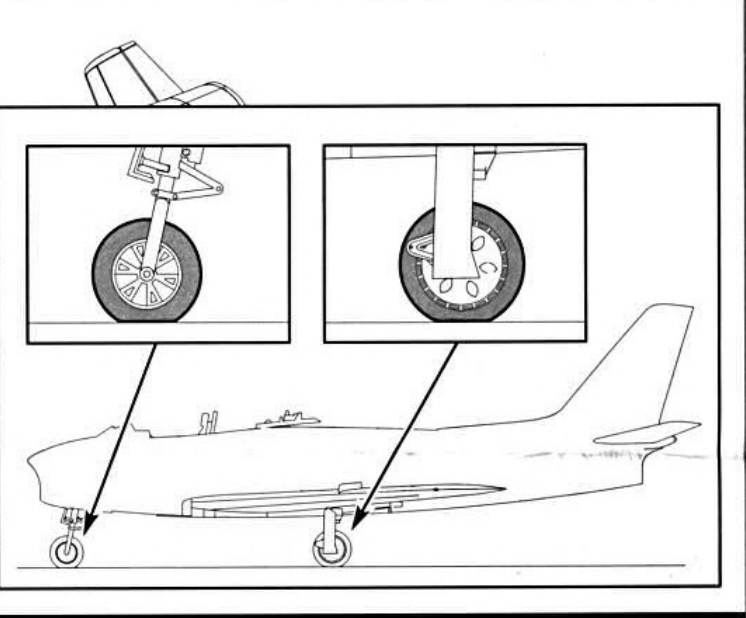
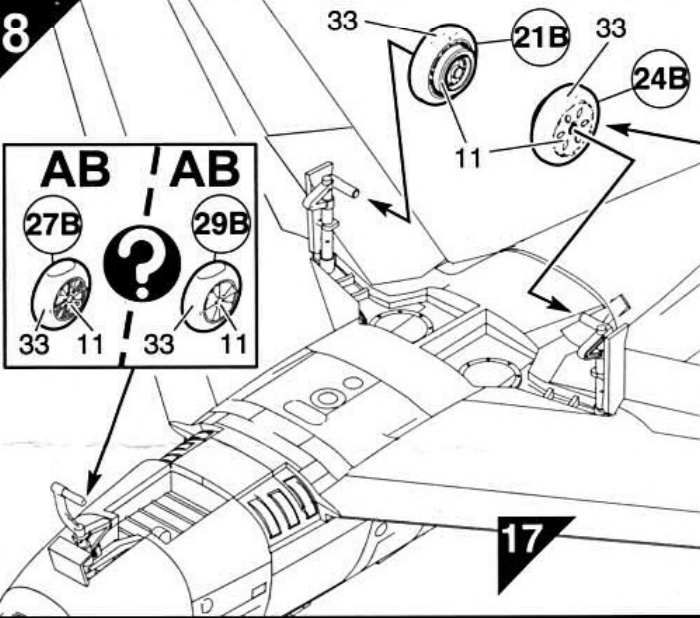

19

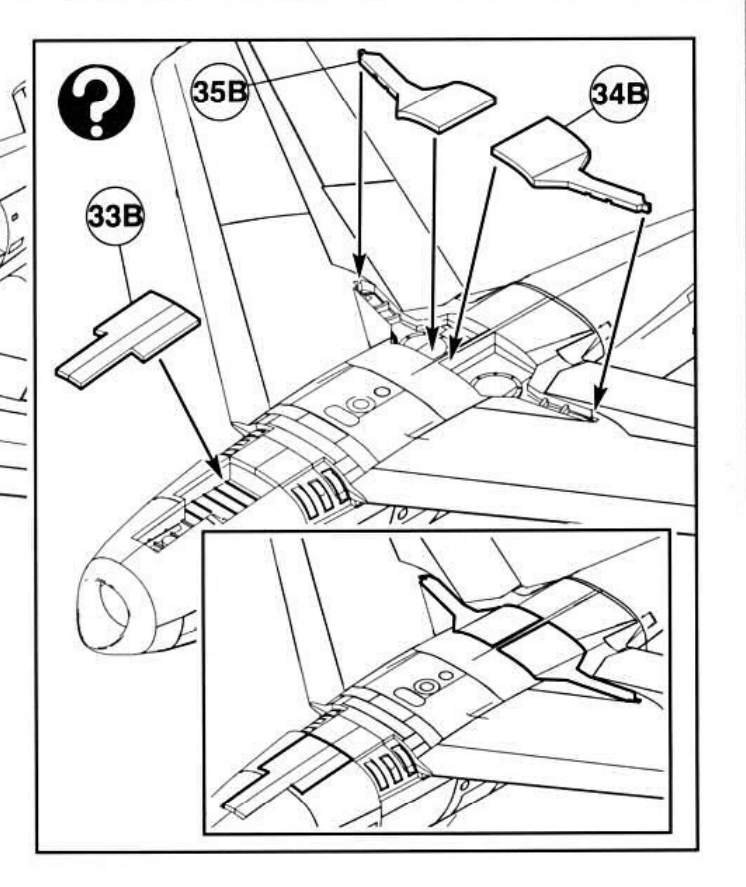
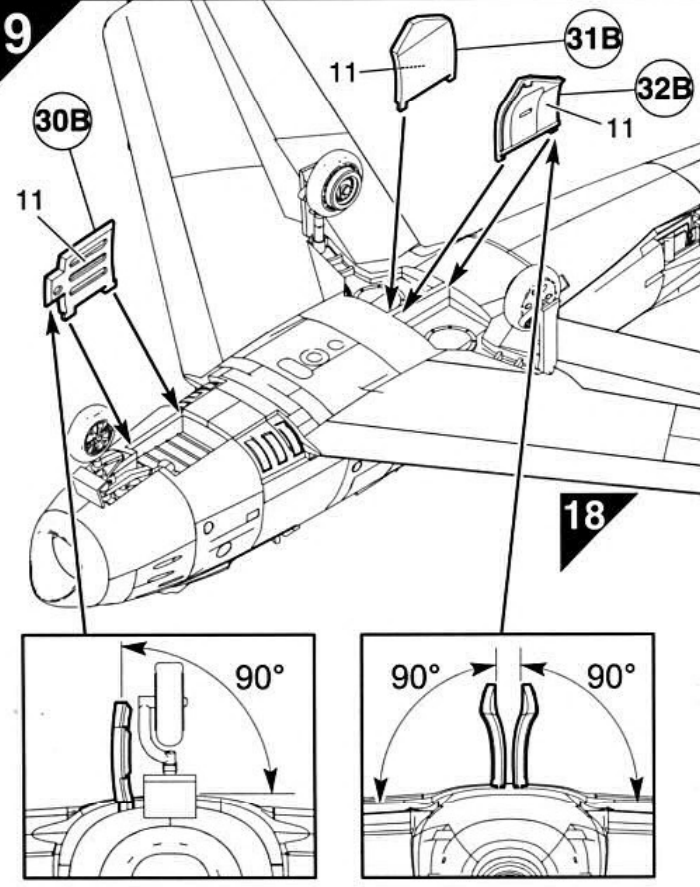

20

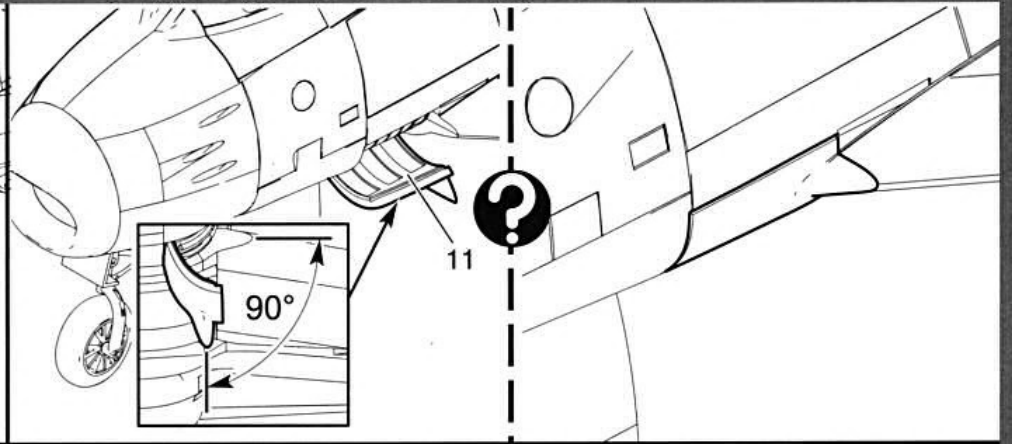
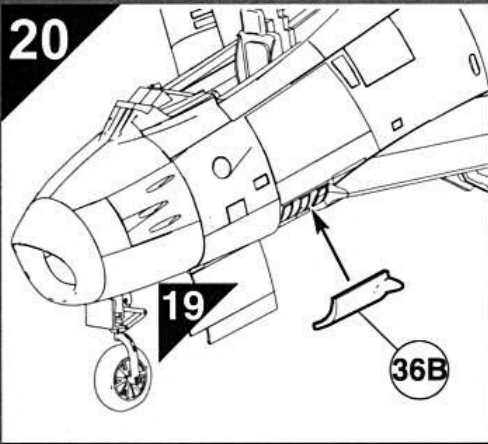

21

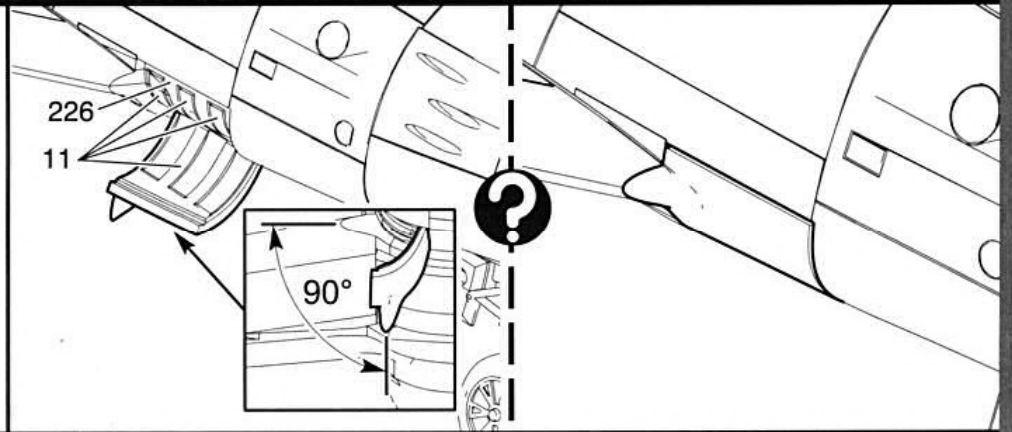
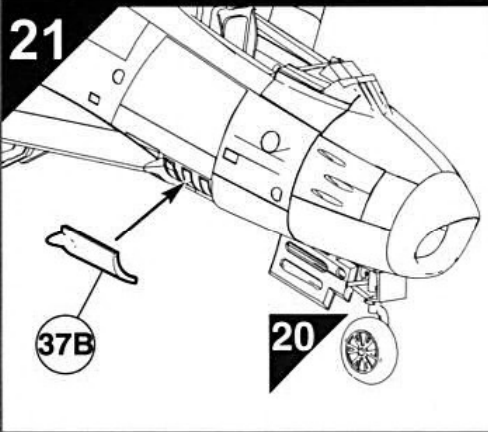

22

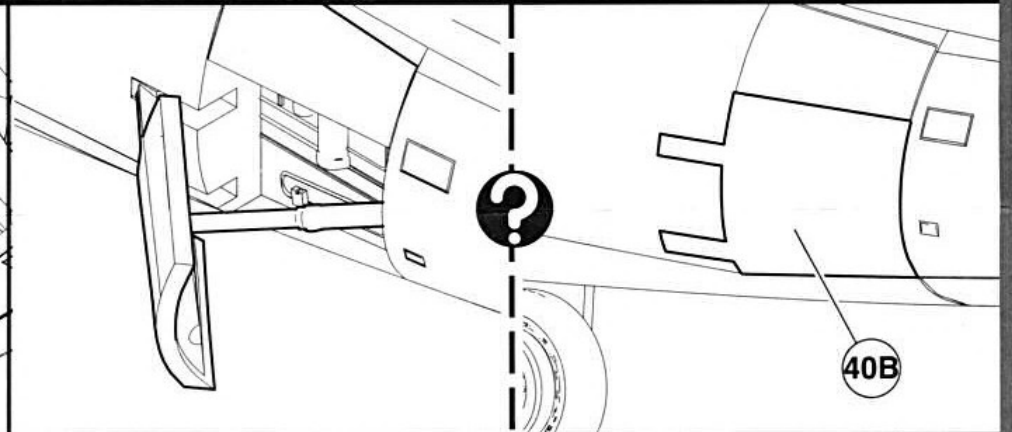
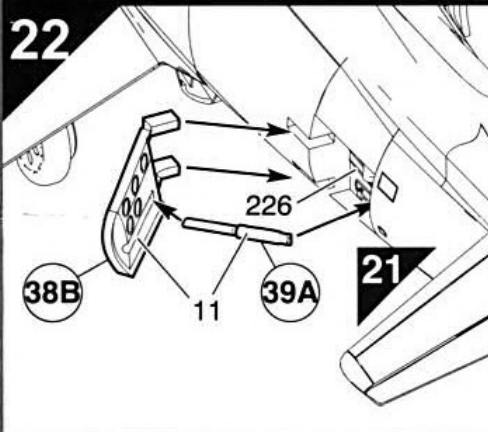

23

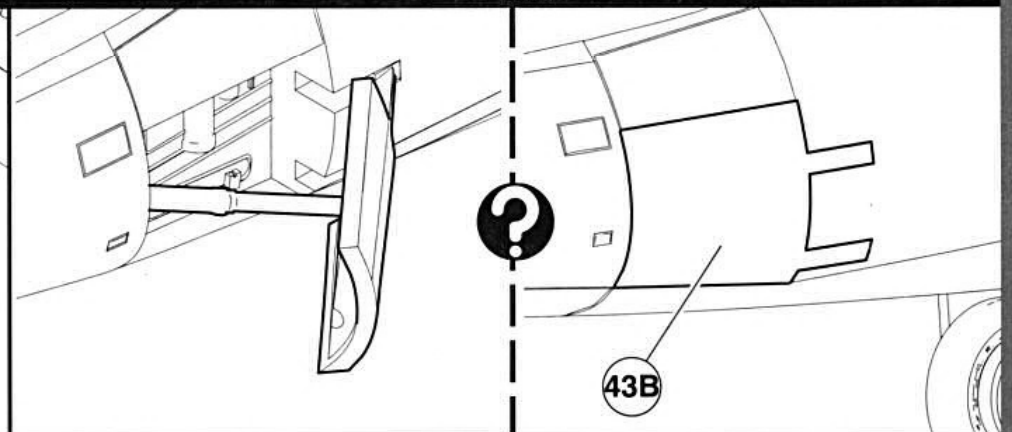
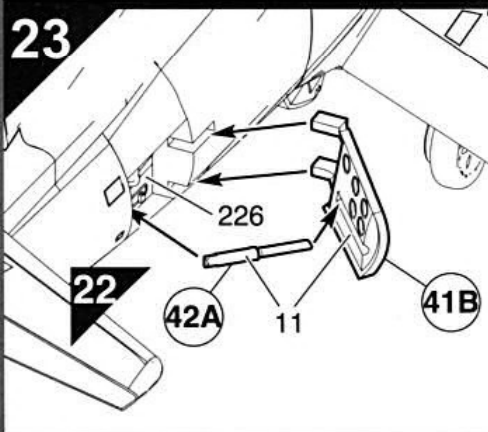

24

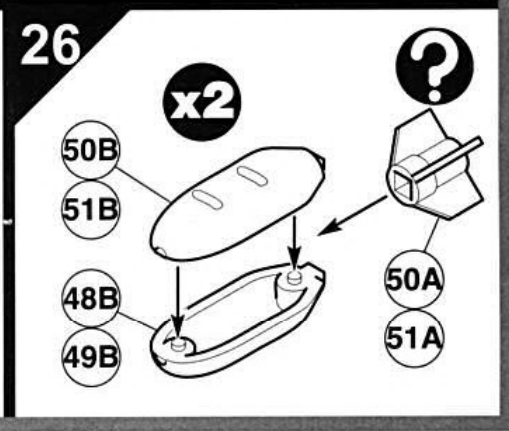
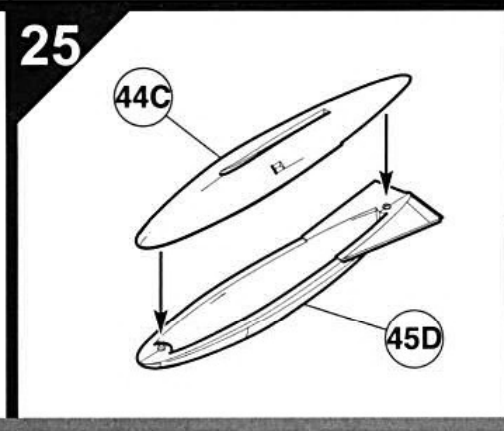
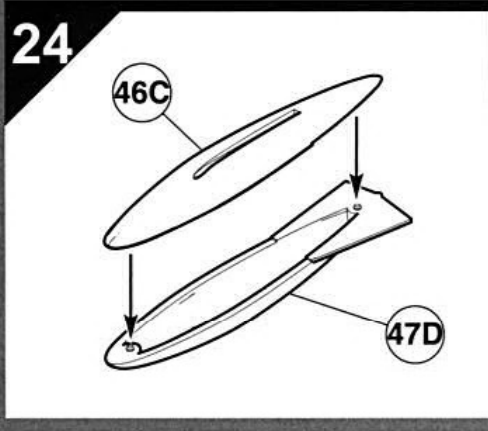

27

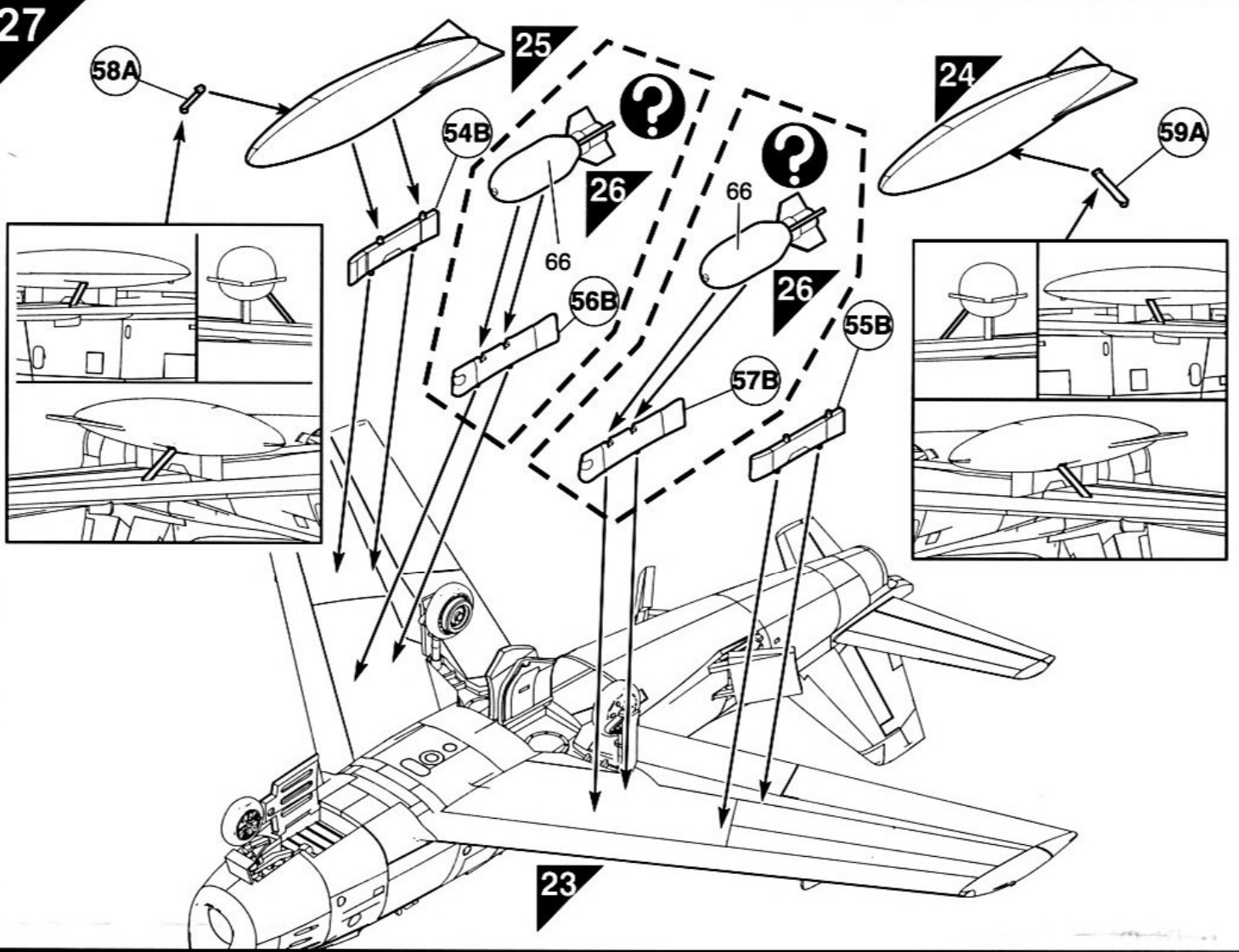

28

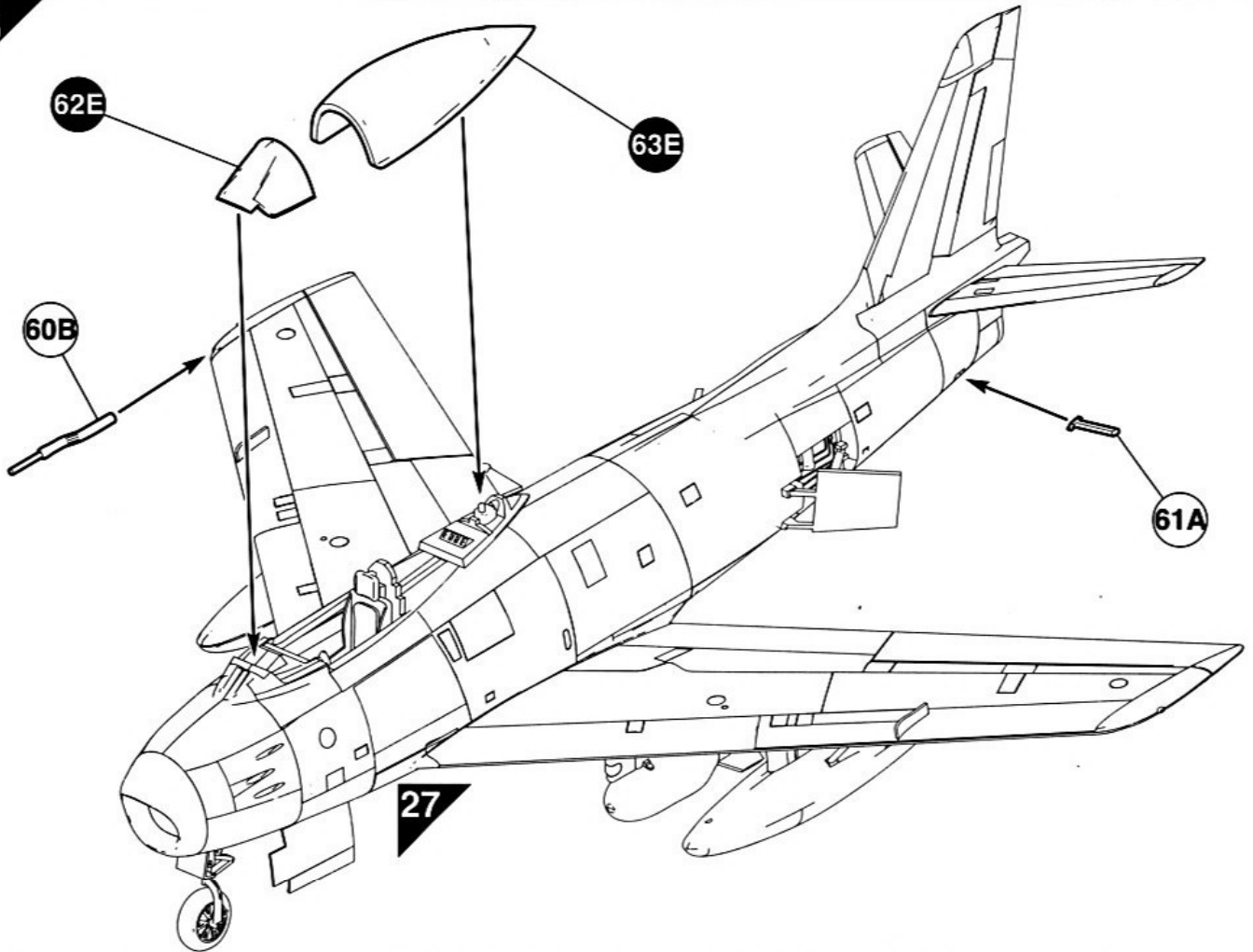

F-86 Sabre

Position of common stencil data

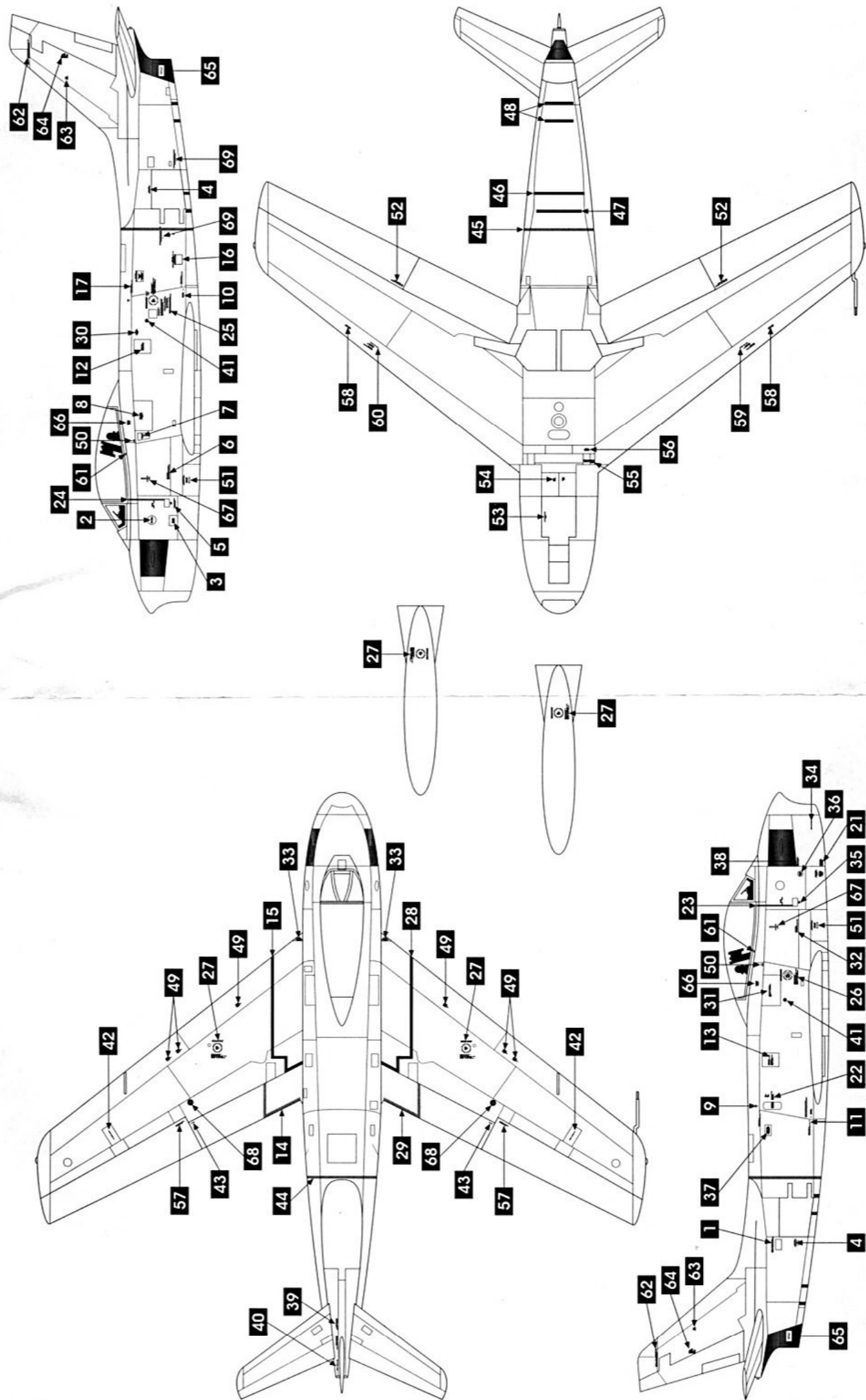

A F-86F Sabre

“The Huff”, flown by Lt. Jim Thompson, 39th Fighter Interceptor Squadron, K-13 (Suwon AB), South Korea, June 1953.

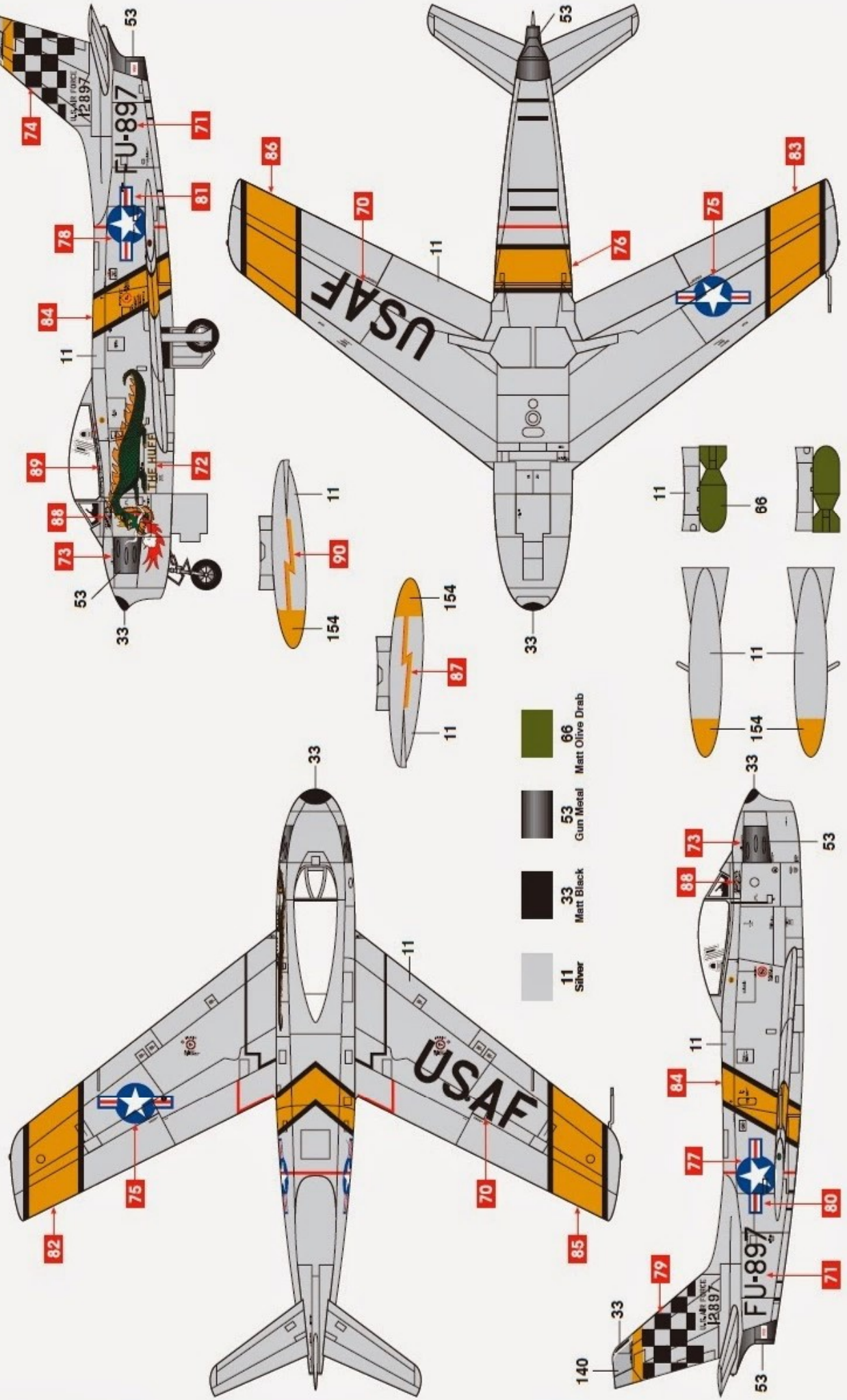

F-86E(M) Sabre
 4th Stormo, Aviazione Militaire Italiana, Grosseto, Italy. 1958.

