

MONOGRAM

F-117A STEALTH

SnapTite®

KIT 1148

1/72 SCALE MASSTAB 1:72 ESCALA 1/72

SCHAAL 1:72 1/72 ECHELLE SKALA 1/72 SCALA 1/72

85114820201

MONOGRAM MODELS, INC. Des Plaines, IL Copyright © 1991 All rights reserved. Made in U.S.A.

Shrouded in mystery . . . it's very existence denied by the U.S. Air Force, the F-117A was announced in April of 1990 as the world's first operational Stealth fighter. Specifically designed to evade enemy radar by being virtually invisible to emitted radar waves, the F-117A was designed and constructed by the aviation wizards of the famed Lockheed "Skunk Works". This strange aircraft is a unique assemblage of flat external surfaces and the advanced airframe relies on non-metallic materials throughout. The aircraft is a single-place design that is powered by two F-117 non-afterburning engines. To reduce the infrared heat

signature and minimize detection, the exhaust outlets are fitted with diffusers that mix cool air with heated exhaust gases to spread and cool the exhaust plume. Armament is carried internally in an internal weapons bay.

Your 1/72nd scale replica utilizes snap-together assembly to simplify construction. Every precise detail is scaled from actual photos of the real aircraft. The shrouded engine intakes are readily visible as are the unusual exhausts. Molded in black plastic, the finished model can be mounted on a two-piece display to portray the "Nighthawk" in flight.

- THIS KIT MAY BE SNAPPED TOGETHER, BUT PARTS MAY BE CEMENTED IF YOU PREFER.
- DIE TEILE DIESES BAUSATZES WERDEN DURCH ZUSAMMENSTECKEN VERBUNDEN KÖNNEN JEDOCH, FALLS GEWÜNSCHT, VERKLEBT WERDEN.
- ESTE KIT PUEDE SER ENSAMBLADO A PRESION PERO LAS PIEZAS SE PUEDEN UNIR CON PEGAMENTO SI SE PREFERE.
- DEZE KIT KAN NAAR KEUSE MET OF ZONDER

- LIJM WORDEN GEMONTEERD.
- CETTE MAQUETTE S'ASSEMBLE PAR SIMPLE PRESSION, MAIS VOUS POUVEZ COLLER LES PIECES SI VOUS LE PREFEREZ.
- DENNA BYGGSATS KAN SNÄPPAS IHOP, MEN DELAR KAN LIMMAS IHOP OM SÅ FÖREDRAS.
- IL MONTAGGIO DEL CONTENUTO DI QUESTA SCATOLA PUO ESSERE EFFETTUATO CONGIUNGENDO LE PARTI A SCATTO A SCELTA, POSSIBILE ANCHE INCOLLARLE.

READ THIS BEFORE YOU BEGIN

- Study the assembly drawings.
- Each plastic part is identified by a number
- Allow paint to dry thoroughly before handling parts.
- For better paint and decal adhesion, wash the plastic parts in a mild detergent solution. Rinse and let air dry.

ALLGEMEINE HINWEISE

- Die Anordnung der Bauteile ist aus den Zeichnungen der Anleitung ersichtlich.
- Jedes Plastikteil ist durch eine Nummer gekennzeichnet.
- Bemalte Teile vor der Weiterverwendung gut trocknen lassen.
- Damit die Farbe und die Abziehbilder besser kleben, sind die Plastikteile in einer milden Seifenlauge zu waschen. Dann abspülen und an der Luft trocknen lassen.

LEA ESTO ANTES DE EMPEZAR

- Estudie los dibujos de ensamblaje.
- Cada pieza de plástico se identifica por un número.
- Permita que se seque la pintura completamente antes de tocar las piezas.

- Para una mejor fijación de la pintura y de las calcomanías, lávase las piezas plásticas en una solución de detergente suave. Enjuáguese y déjense secar al aire.

LEES DIT ALVORENS TE BEGINNEN

- Bestudeer de bouwtekening.
- Elk plastic onderdeel is genummerd.
- Laat de verf van de te verwerken delen steeds goed drogen.
- Zodat de verf en etiketten beter zullen plakken, was de plasticke delen in een milde seep oplossing. Spoel en laat in de openlucht opdrogen.

LISEZ CE QUI SUIT AVANT DE COMMENCER LE MONTAGE

- Etudier les schémas d'assemblage.
- Chaque pièce plastique porte de numéro d'identification.
- Laissez sécher la peinture complètement, avant de manipuler les pièces.
- Pour assurer la meilleure adhesion possible de la peinture et des calcomanies, laver les pièces

- de plastique avec une légère solution savonneuse. Rincer et laisser sécher à l'air.

LAS DET HAR INNAN DU BORJAR BYGGA

- Studera monteringskisserna.
- Alla plastdelar har identifikationsnummer.
- Modellen kan målas enligt foton på kantongen.
- Låt färgen torka ordentligt före limningen.
- För bättre vidhäftning av färg och dekalmarken rengör plastdelarna i en mild tvättmedelslösning. Skölj och låt lufttorka.

DA LEGGERE PRIMA DI INIZIARE

- Studia le illustrazioni.
- Ogni pezzo è identificato da un numero.
- Il modello si può dipingere seguendo le fotografie sulla scatola.
- Aspetta che la vernice sia completamente asciutta prima di maneggiare le parti.
- Per una migliore aderenza di vernice e decalcomania lavare le parti in plastica in soluzione detergente non abrasiva. Risciacquare e lasciar asciugare all'aria.

A	SATIN BLACK	HALBGLÄNZENDES SCHWARZ	NEGRO MATE	MAT ZWART	NOIR MAT	GRÅSVART	NERO SEMIOPACO
B	WHITE	WEISS	BLANCO	WIT	BLANC	VIT	BIANCO
C	SKIN COLOR	HAUTFARBE	COLOR DE LA PIEL	HUIDKLEUR	COULEUR DE LA PEAU	HUDFÄRGE	COLORE DELLA PELLE
D	OLIVE GREEN	OLIVGRÖN	VERDE OLIVA	OLIJFGROEN	VERT OLIVE	OLIVGRÖN	VERDE OLIVA



APPLY STICK-ON DECALS
DIE AUFKLEBER ANFETIGEN
APPLIQUEZ LES AUTO-COLLANTS
APLIQUE LAS CALCOMANIAS ENGOMADAS
PLAK DE ZELFKLEVENDE STICKERS
SÄTT FAST STICK-ON-DEKALERNA
APPLICARE GLI ADESIVI



DO NOT CEMENT
NICHT KLEBEN
NO USE PEGAMENTO
NIET LIJMEN
NE PAS COLLER
LIMMAS INTE
NON INCOLLARE



REMOVE AND THROW AWAY
ENTFERNEN (ABFALL)
QUITE Y TIRE
VERWIJDEREN EN WEGGOEDEN
À RETIRER ET JETER
AVLAGSNAS OCH MAKULERAS
RIMOUVI ED' ELIMINA

1

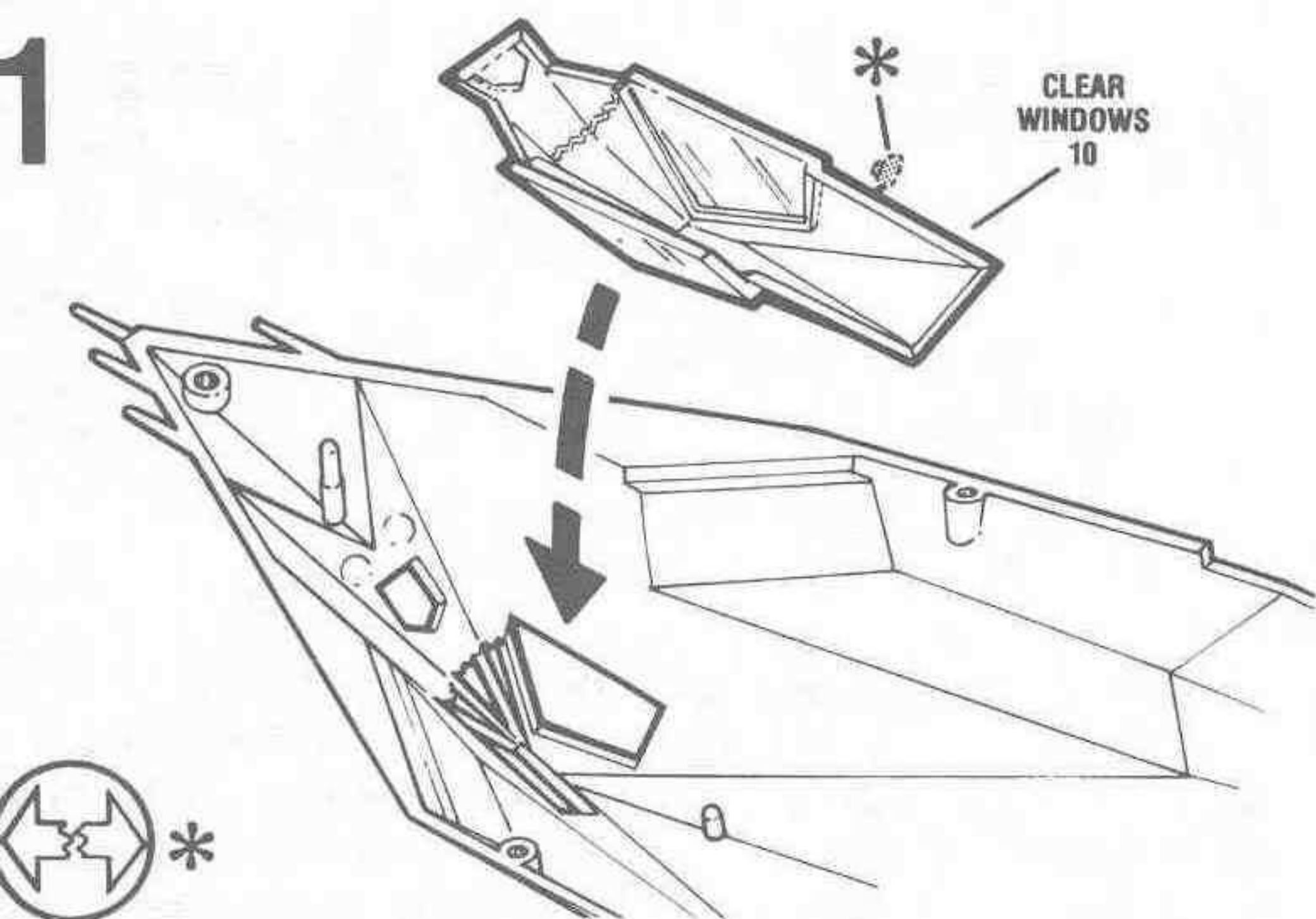

2

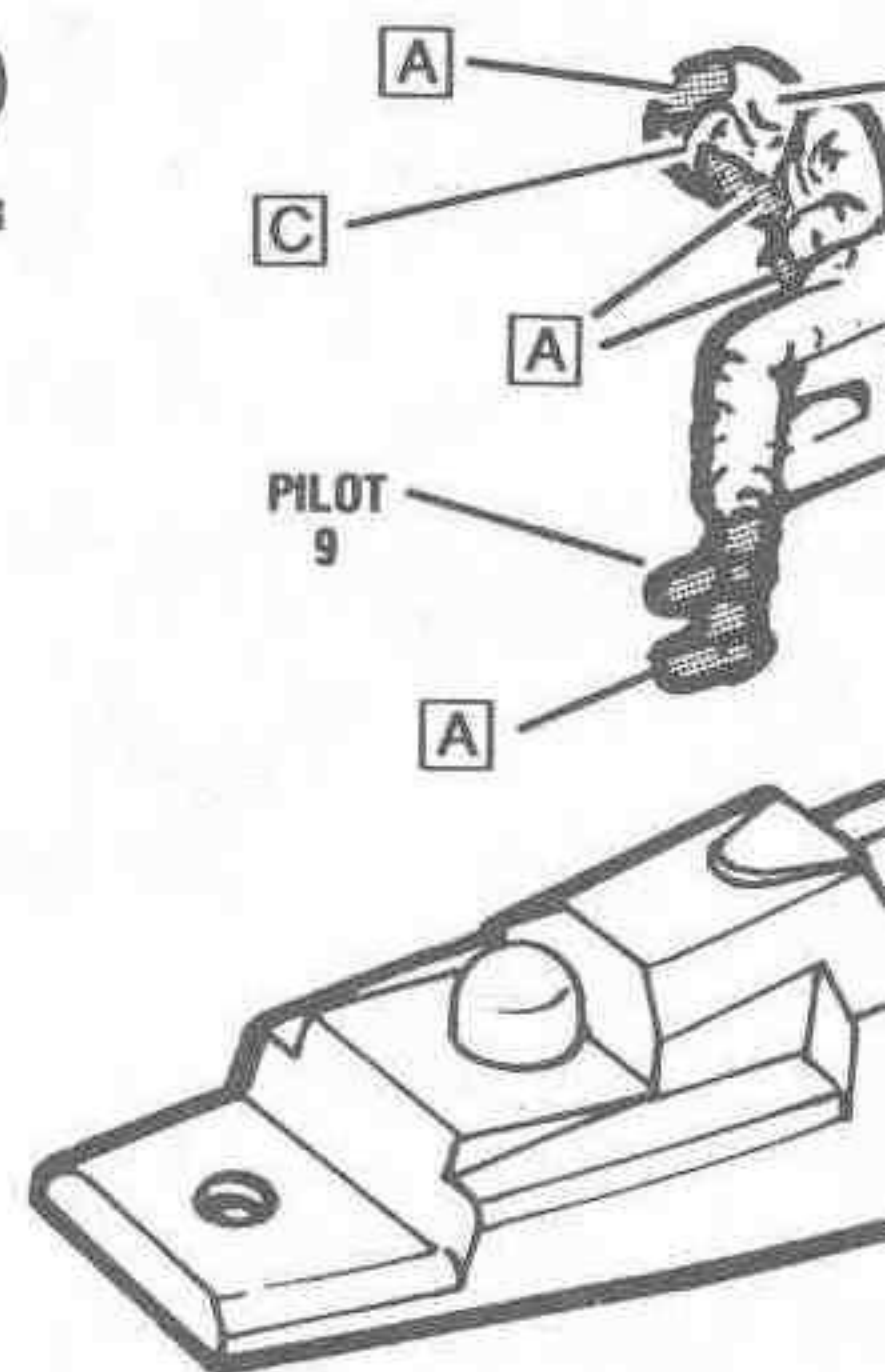

4

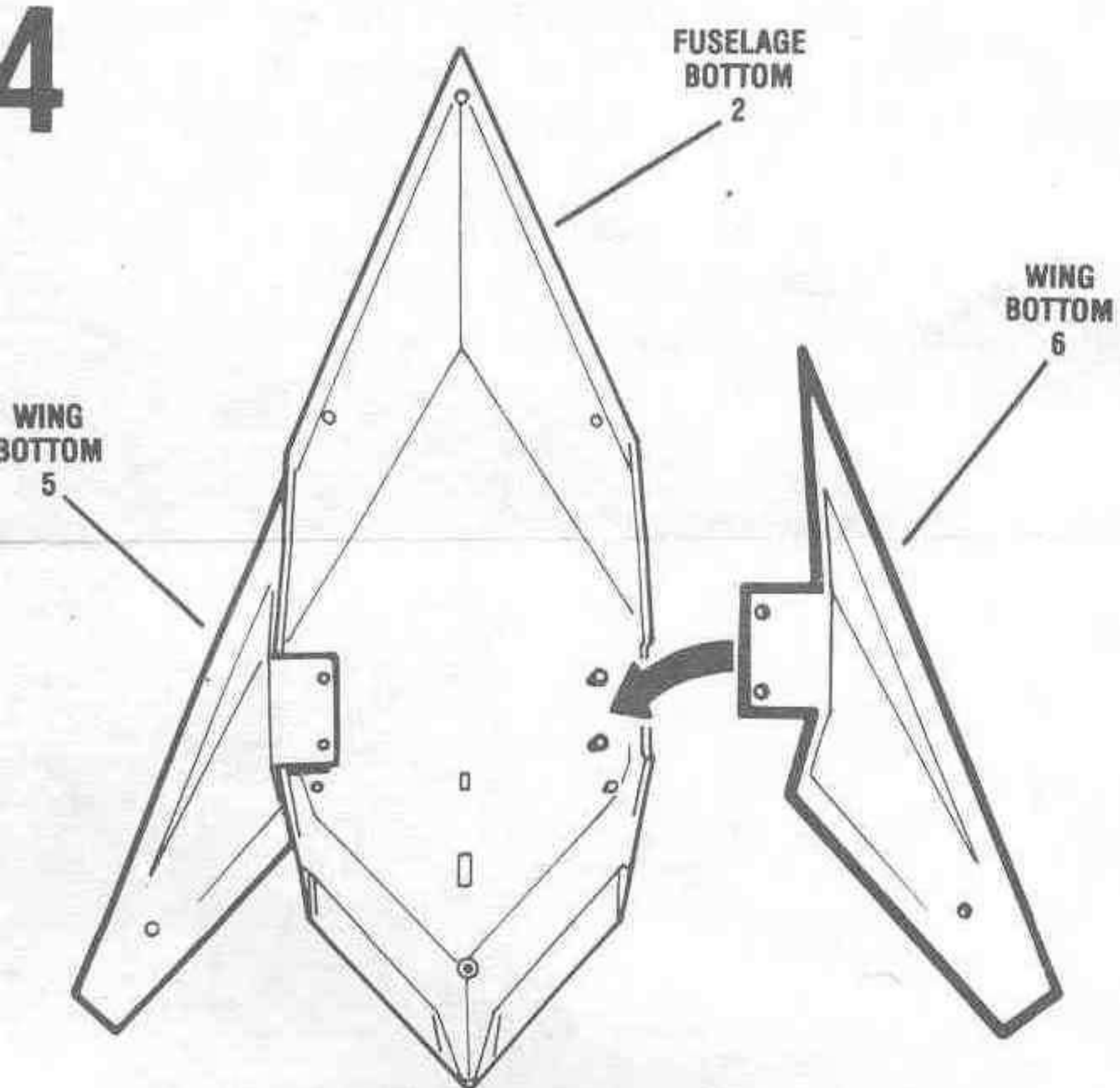

5

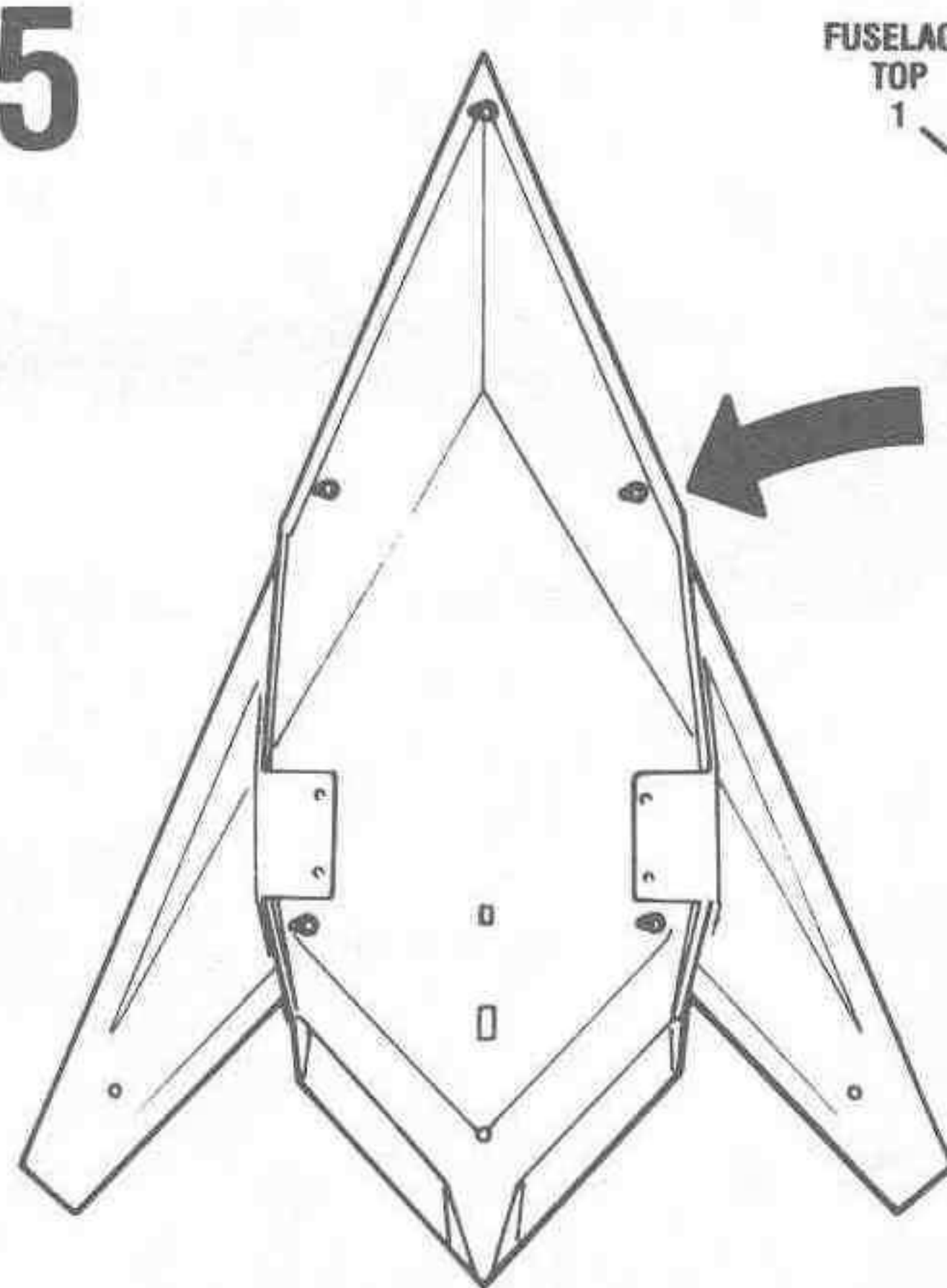

7

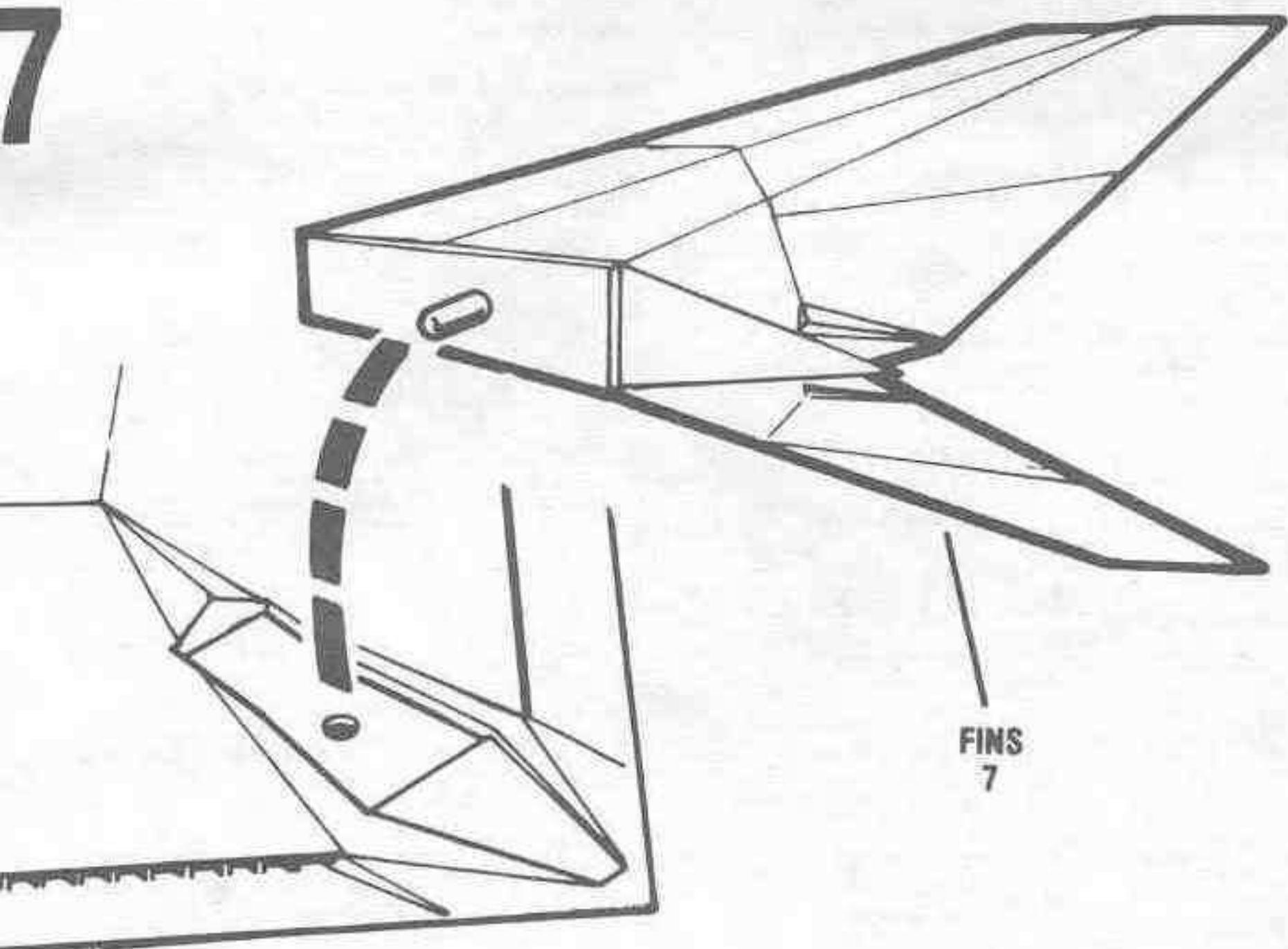

8

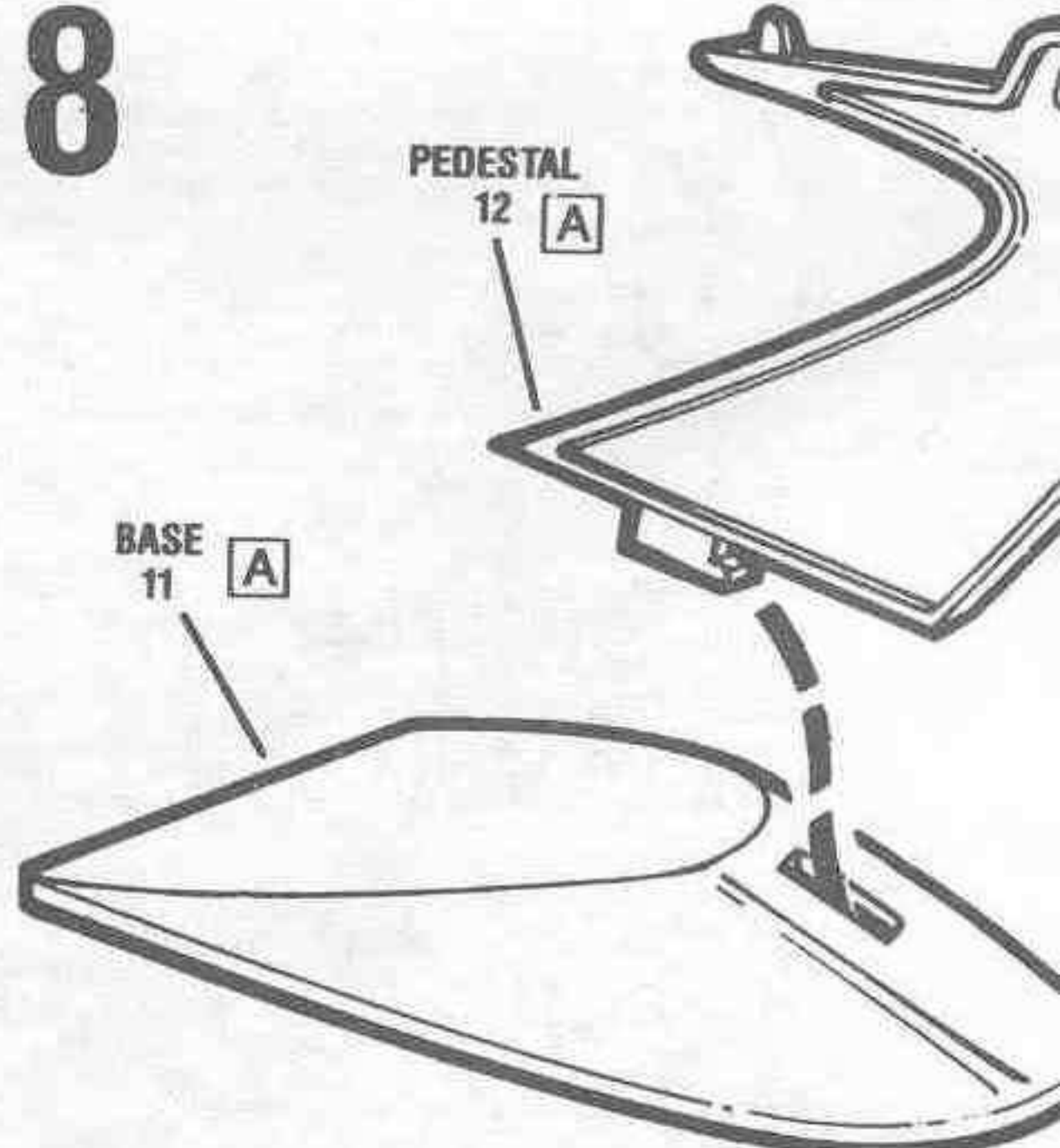

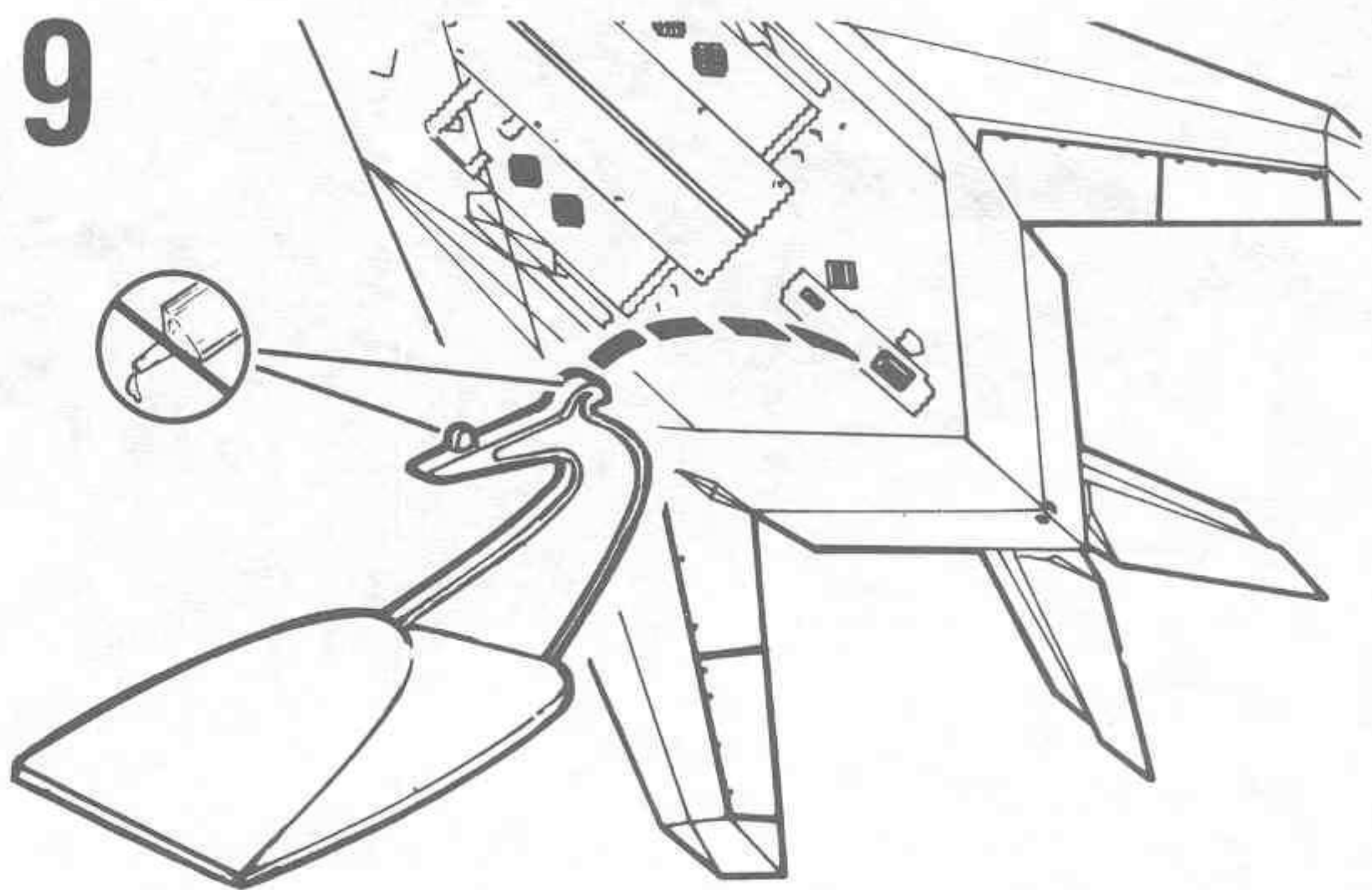
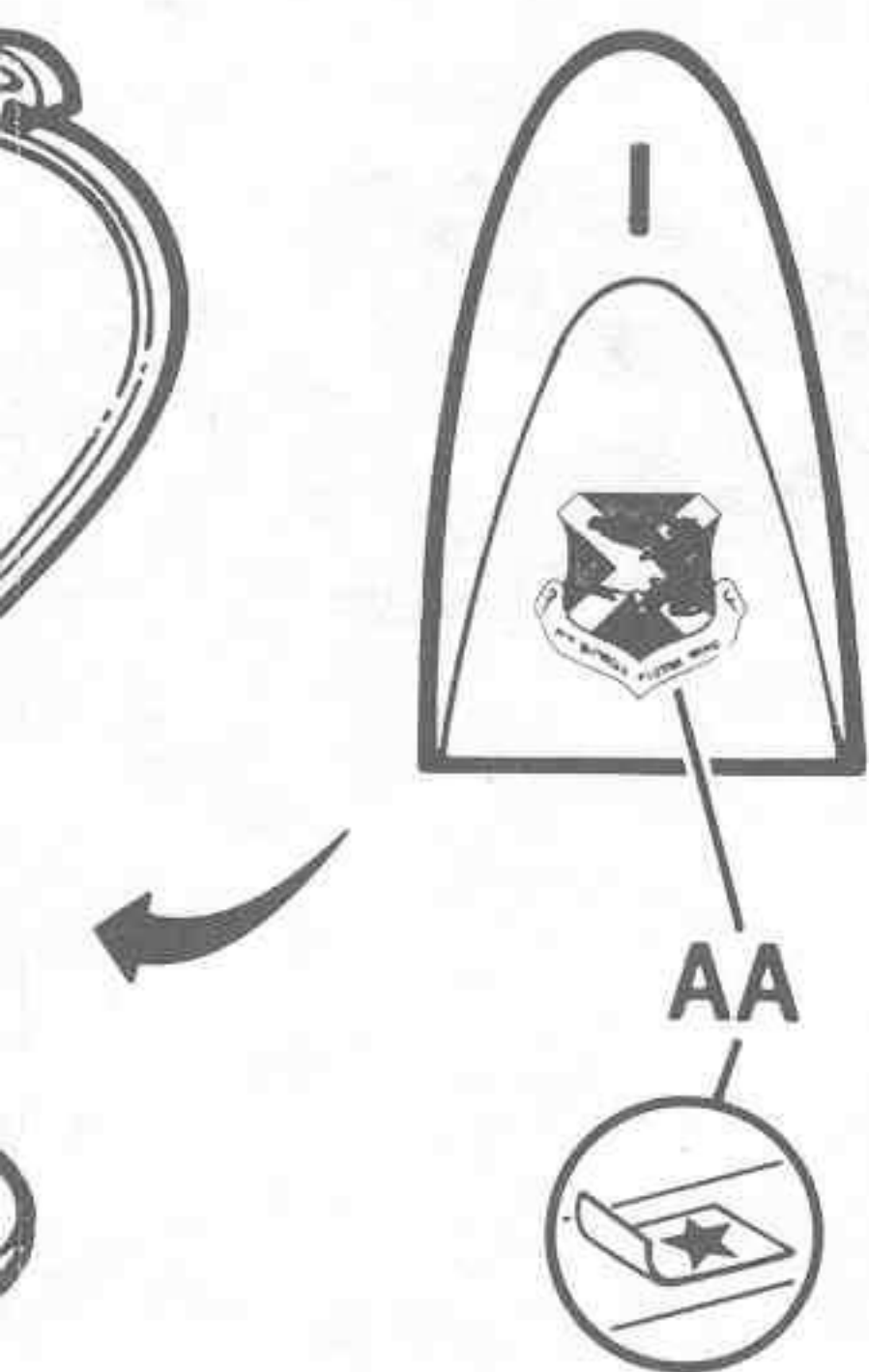
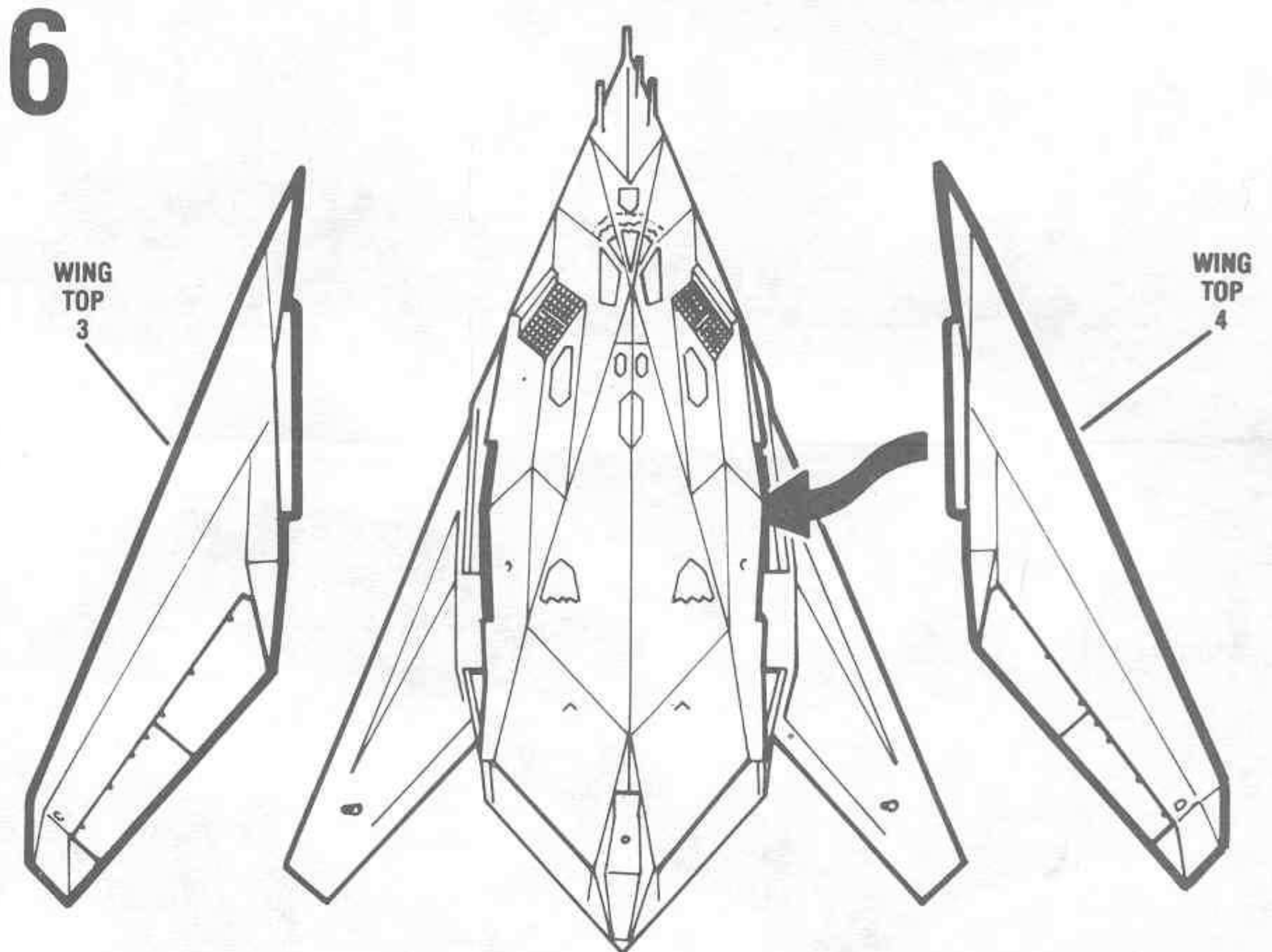
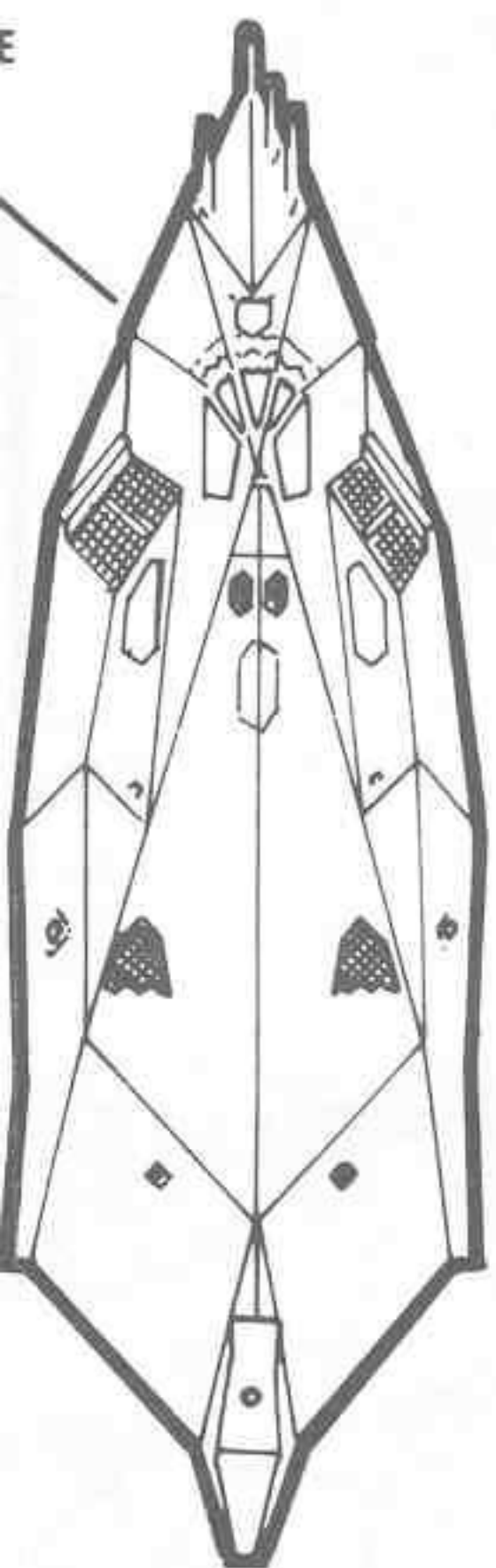
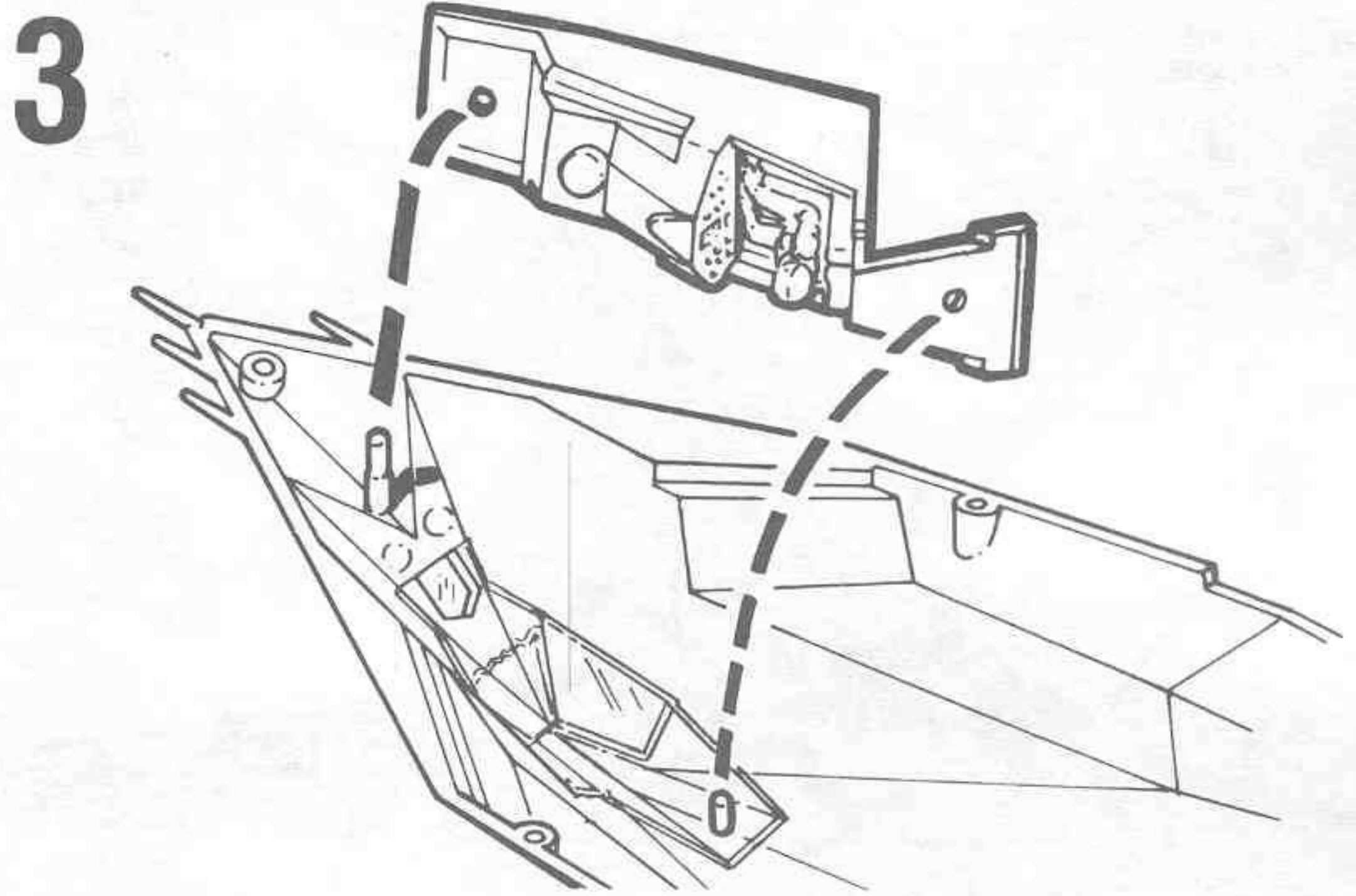
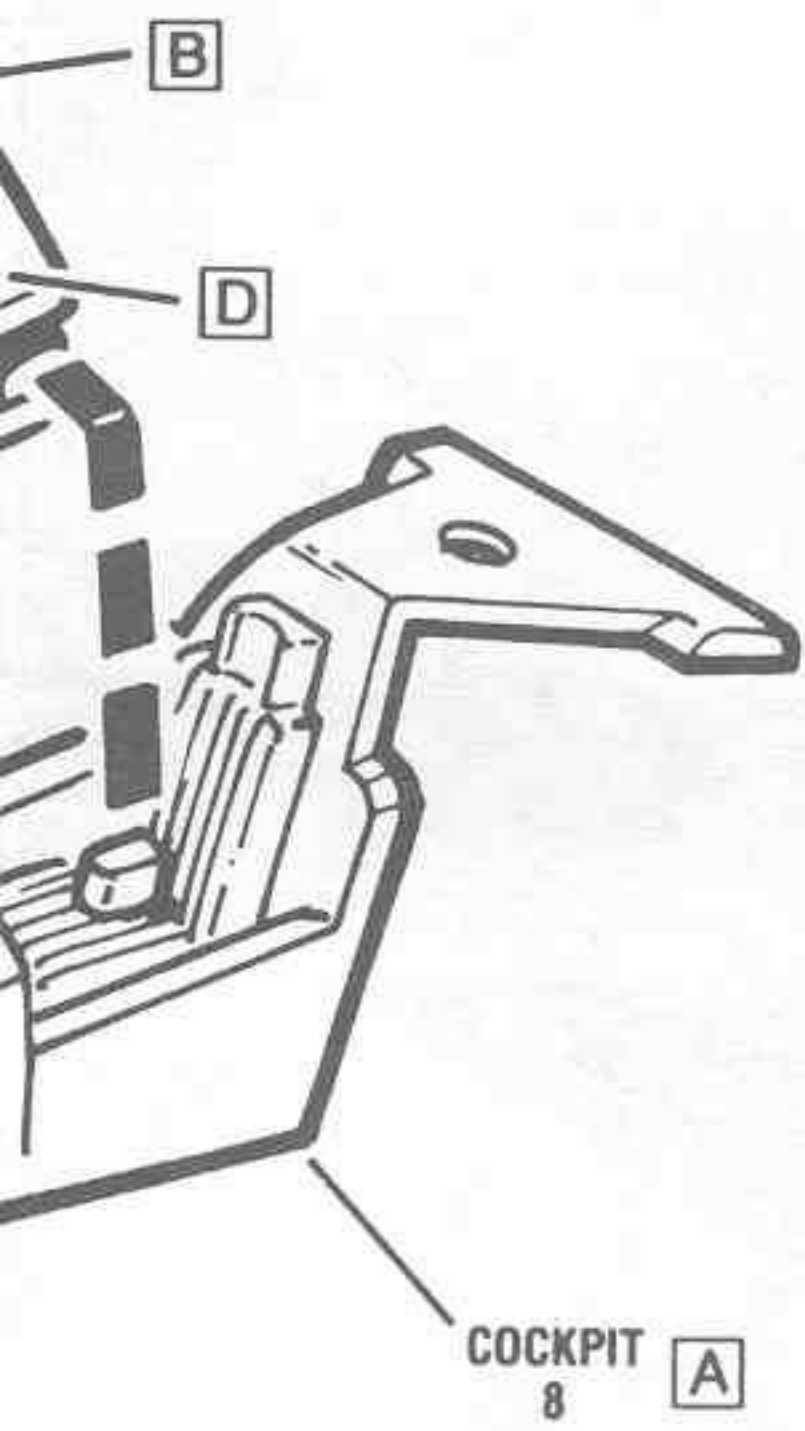

If you have any problems building this model,
call our modeling tips hotline at:

(800) 833-3570

Every effort has been made to create and manu-
facture a model kit that is the finest available. If a
part may be missing, please write to:

Revell-Monogram
Consumer Service Department
8601 Waukegan Road
Morton Grove, Illinois 60053

Be sure to include the kit number, part number,
description, and your return address.

