

P-51D-5 Mustang™

eduard

1/48 Scale Plastic Model Kit



Produced under license

Boeing, P-51 Mustang, their distinctive logos, product markings and trade dress are trademarks of The Boeing Company.

ProfiPACK edition



item No. 82101

The P-51 Mustang is one of the finest fighters of all time and although American design, it owes a lot to the Great Britain for its genesis and development.

It was in 1940, when British Buying Committee asked North American Aviation (NAA) to build the Curtiss P-40s for the RAF. NAA president James Kindelberger offered Britons development of much better plane instead. Britons agreed and the design team led by chief designer Edward Schmued, who was German immigrant with Austrian roots, commenced their work. The preliminary design was approved on May 4, 1940, final assembly and engine installation began on September 9 (just 127 days after approval) and the first flight of the NA-73X prototype followed on October 26.

Innovative fighter

The Allison V-1710-39 liquid cooled in-line engine rated at 1,100 HP was chosen for the new fighter and the designers did their best to create as narrow and sleek fuselage as possible to lower the drag. For the same reason they decided to use an innovative laminar flow airfoil reducing drag, but, on the other hand, requiring smooth surface to work properly. That necessitated to putty and sand the leading area of the wing. Another design novelty was the radiator belly under the fuselage, which also developed additional thrust thanks to the Meredith effect. Armament consisted of two guns in the nose and four in the wings, all of them .50 caliber Brownings (the Mk. Ia variant had four 20mm cannons). Britons chose the name Mustang for the new aircraft, later adopted by USAAF as well. The RAF received first Mustangs Mk.I in October, 1941. The performance was found satisfactory, as they were faster than Spitfires Mk.V and had more than double the range. On the other side, the Allison engine reached its maximum power output at 11,800 ft (3597 m) because of its one-stage supercharger. Above this level the engine performance decreased rapidly. As the aerial combats occurred much higher, the RAF decided to use their Mustangs in the reconnaissance role and US Army Air Corps, interested in the new type as well (but bound to the contracts to buy P-40s, P-39s and P-38s), asked the NAA to convert the Mustang to dive bomber variant with wing dive brakes (A-36).

Merlin magic

To solve the high-altitude lack of power, the work had begun in Britain to fit the Mustang with the double-stage supercharger Merlin engine. The trials of the Mustang X prototype revealed the level speed of 433 mph (697 km/h) at 22,000 ft (6700 m), thus 100 mph (161 km/h) faster than Mustang Mk. I. As it was obvious this is the way to further develop the Mustang, NAA started the work using Packard V-1650-1 (license built Merlin 61). As the Packard unit sported some design changes, it was not possible to retrofit Mustangs with original Merlins. The need for intercooler for two-stage supercharger necessitated bigger radiator duct. Another change included removal of the fuselage guns. The production started at the Inglewood plant as P-51B on May and at the new production line at NAA Dallas plant as P-51C in August, 1943. Supplies to RAF continued as Mustang

Mk. III. After just handful of new Mustangs were produced, the then commander of US Air Forces in Europe General Henry Arnold asked for even greater range. NAA responded with additional 85-gallon tank installed behind the pilot's seat.

The P-51B/C were great fighters but lacked backward visibility and suffered with gun jamming. The RAF found particle solution of the visibility issue with a „Malcolm Hood“ semi-bubble canopy, but the design team of NAA decided to rework the Mustang again. The main change was the bubble canopy with lowered rear fuselage. The wing was reworked to accommodate six .50 cal guns and the new arrangement of ammo chutes eliminated the jam problem. Together with some other changes, the new P-51D, the „Definitive“ Mustang, was born at the end of 1943 and the production started at both Inglewood (serials with -NA suffix) and Dallas (-NT) plants. Due to the short supply of the Hamilton Standard alloy propellers used on Merlin powered P-51s, the Dallas Factory was fitting their Mustangs with steel Aero-product ones with hollow blades as the P-51K.

The P-51D/K became the true ruler of the skies, serving as the escort and patrol fighter, and also in ground attack or reconnaissance role (F-6 conversion). In total, 8,102 units of P-51D and 1,500 of P-51K were produced. Mustang stayed operational after the War and served in pursuit and attack role even during the Korean War. The last P-51 retired from USAF service in 1978, while in foreign services was operational until 1984 (Dominican Republic). Some 55 nations used the Mustang.

Ace maker and infinite warrior

The first Mustang aerial victory was achieved on August 19, 1942, when Flight Officer Hills shot down an Fw 190. It was the beginning of the incredible tally of 4950 enemy aircraft shot down by Mustang pilots during World War II. Of them, 251 achieved the „ace“ status. The most successful pilot of P-51 was George Preddy Jr., recording 24 of his 27 aerial victories flying Mustang, followed by John C. Meyer and John J. Woll with 21 kills. Famous Charles Yeager, the first man to break the sonic barrier (1947), was the first pilot of P-51D to become Ace in just one day, after recording five kills during October 12, 1944.

The kit: P-51D-5

The D-5 was the first production batch apart of the -INA series (100 examples of unassembled aircraft shipped for Australia). There were 800 P-51D-5NAs produced at Inglewood and the Dallas plant added 200 of P-51D-5NT. The „5“ series was the only to retain the shape of the vertical fin of the P-51B/C. But, as the lowered fuselage behind the bubble canopy reduced the rear side surface area, the directional stability of P-51D suffered. Due to that, starting with the P-51D-10 series, the dorsal fin was added to the stabilizer to remedy the problem and the field conversion kit was distributed to the units already using P-51D-5s.

ATTENTION * UPOZORNĚNÍ * ACHTUNG * ATTENTION * 注意



Carefully read instruction sheet before assembling. When you use glue or paint, do not use near open flame and use in well ventilated room. Keep out of reach of small children. Children must not be allowed to suck any part, or pull vinyl bag over the head.



Před započatím stavby si pečlivě prostudujte stavební návod. Při používání barev a lepidel pracujte v dobře větrané místnosti. Lepidla ani barvy nepoužívejte v blízkosti otevřeného ohně. Model není určen malým dětem, mohlo by dojít k požití drobných dílů.

INSTRUCTION SIGNS * INSTR. SYMBOLS * INSTRUKTION SINNBILDEN * SYMBOLES * 記号の説明

- 
 OPTIONAL
VOLBA
- 
 BEND
OHNOUT
- 
 SAND
BROUSIT
- 
 OPEN HOLE
VYVRTAT OTVOR
- 
 SYMETRICAL ASSEMBLY
SYMETRICKÁ MONTÁŽ
- 
 REMOVE
ODRÍZNOUT
- 
 REVERSE SIDE
OTOČIT
- 
 APPLY EDUARD MASK
AND PAINT
POUŽIT EDUARD MASK
NABARVIT

PARTS * DÍLY * TEILE * PIÈCES * 部品

PLASTIC PARTS

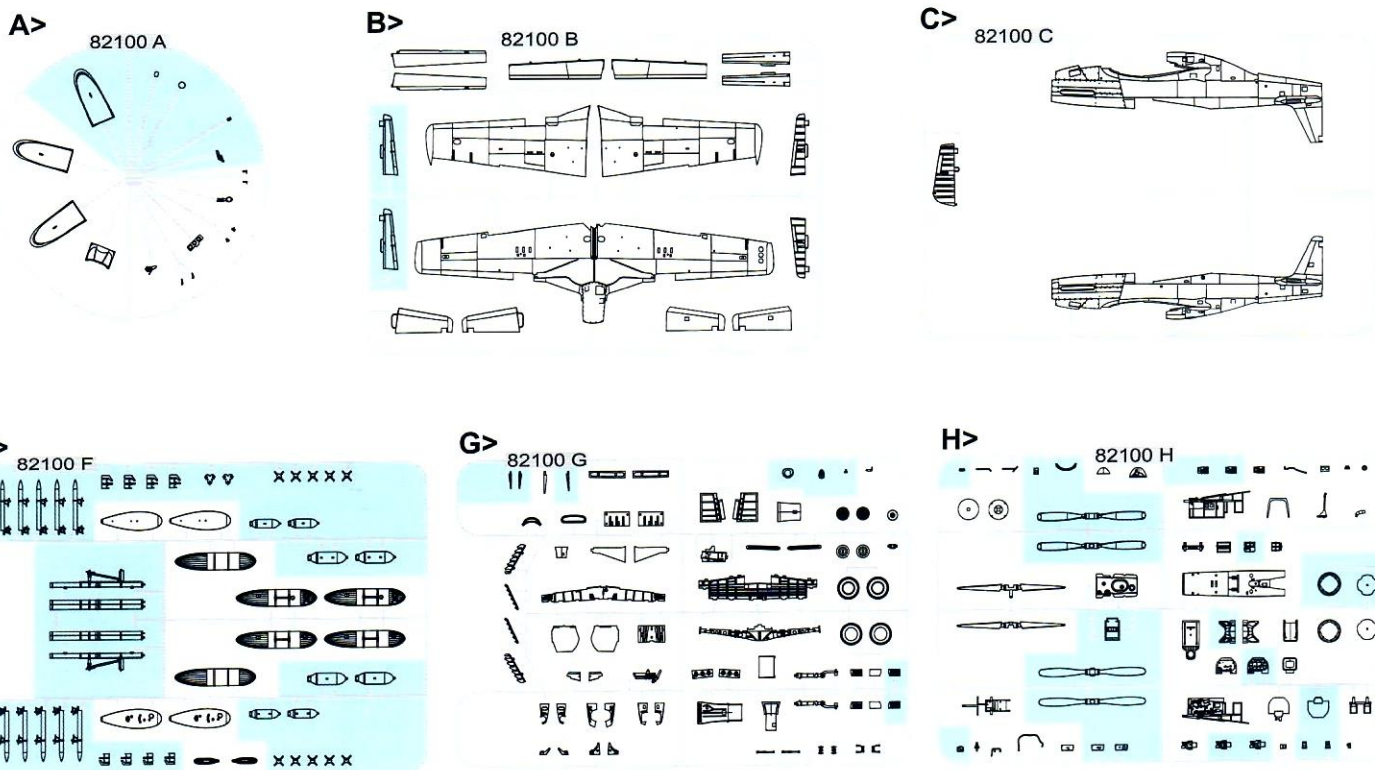

PE - PHOTO ETCHED DETAIL PARTS

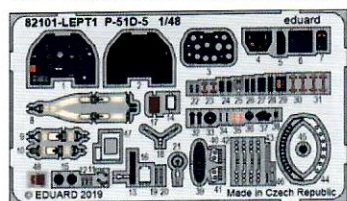

eduard MASK

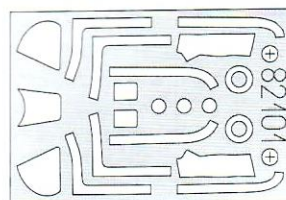

-Parts not for use. -Teile werden nicht verwendet. -Pièces à ne pas utiliser. -Tyto díly nepoužívejte při stavbě. - 使用しない部品

COLOURS * BARVY * FARBEN * PEINTURE * 色

GSI Creos (GUNZE)		MISSION MODELS	
AQUEOUS	Mr.COLOR	PAINTS	
H1	C1	MMP-001	WHITE
H8	C8		SILVER
H11	C62	MMP-001	FLAT WHITE
H12	C33	MMP-047	FLAT BLACK
H15	C65		BRIGHT BLUE
H27	C44		TAN
H37	C43		WOOD BROWN
H47	C41	MMP-012	RED BROWN
H52	C12	MMP-091	OLIVE DRAB
H53	C13		NEUTRAL GRAY
H58	C351	MMP-059	INTERIOR GREEN
H77	C137	MMP-040	TIRE BLACK
H90	C47		CLEAR RED

GSI Creos (GUNZE)		MISSION MODELS	
AQUEOUS	Mr.COLOR	PAINTS	
H91	C48		CLEAR YELLOW
H94	C138		CLEAR GREEN
H327	C327	MMP-101	RED
H329	C329		YELLOW
H330	C361	MMP-077	GREEN
H335	C363	MMP-094	MEDIUM SEA GRAY
H422	C122	MMP-053	GREEN
	C352	MMP-067	CHROMATE YELLOW
Mr.METAL COLOR		METALLICS	
MC214		MMM-001	DARK IRON
Mr.COLOR SUPER METALLIC		METALLICS	
SM201		MMC-001	SUPER FINE SILVER
SM203			SUPER IRON

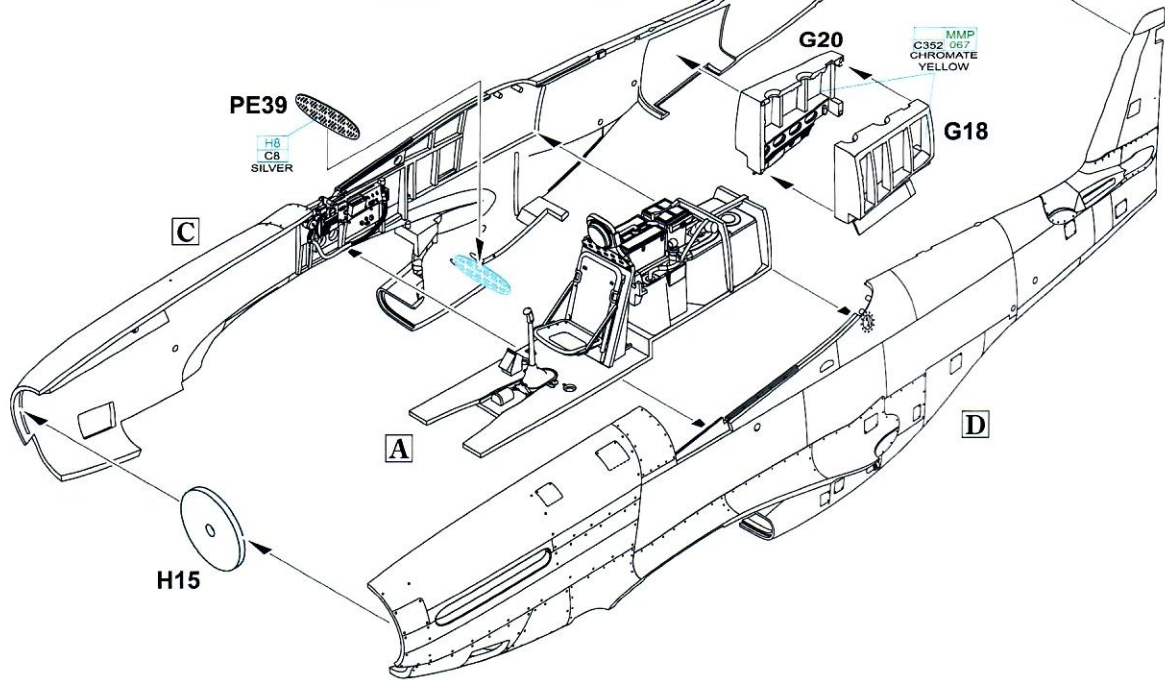
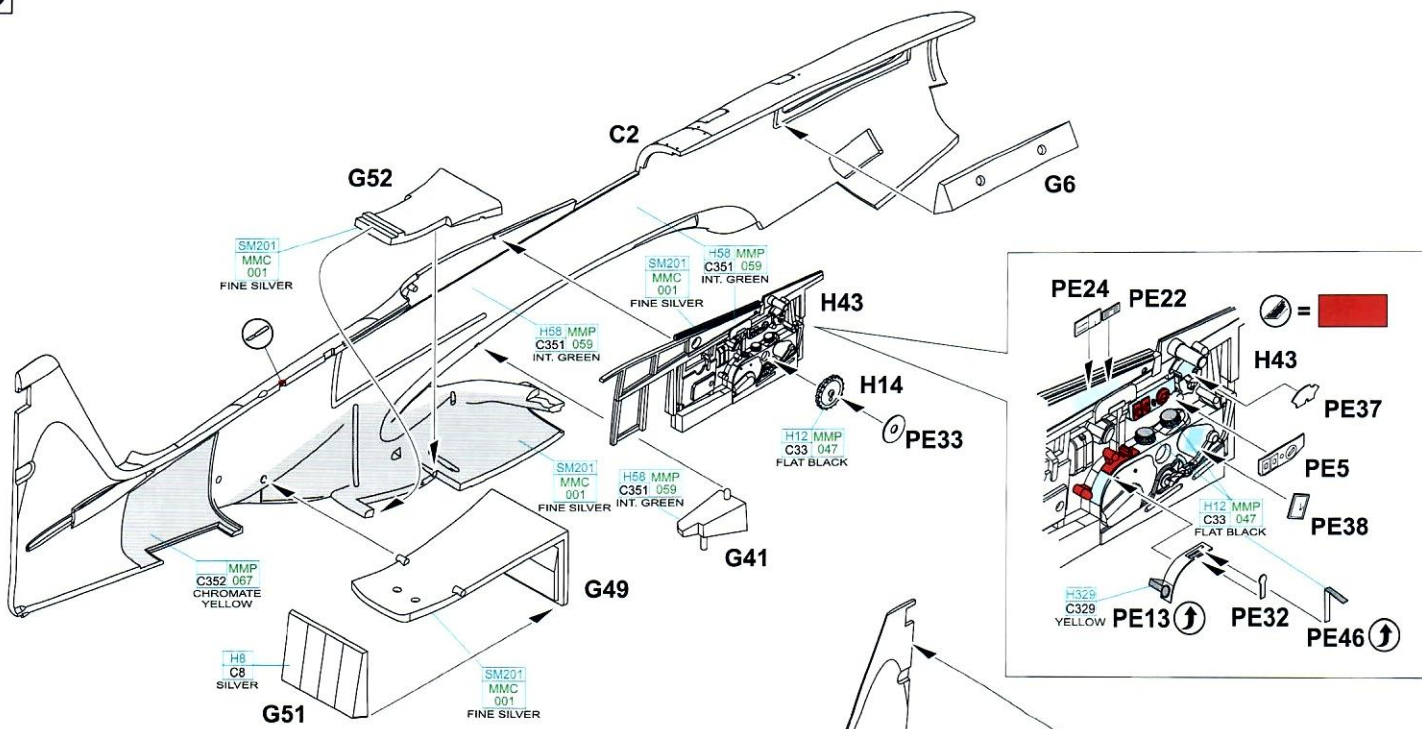
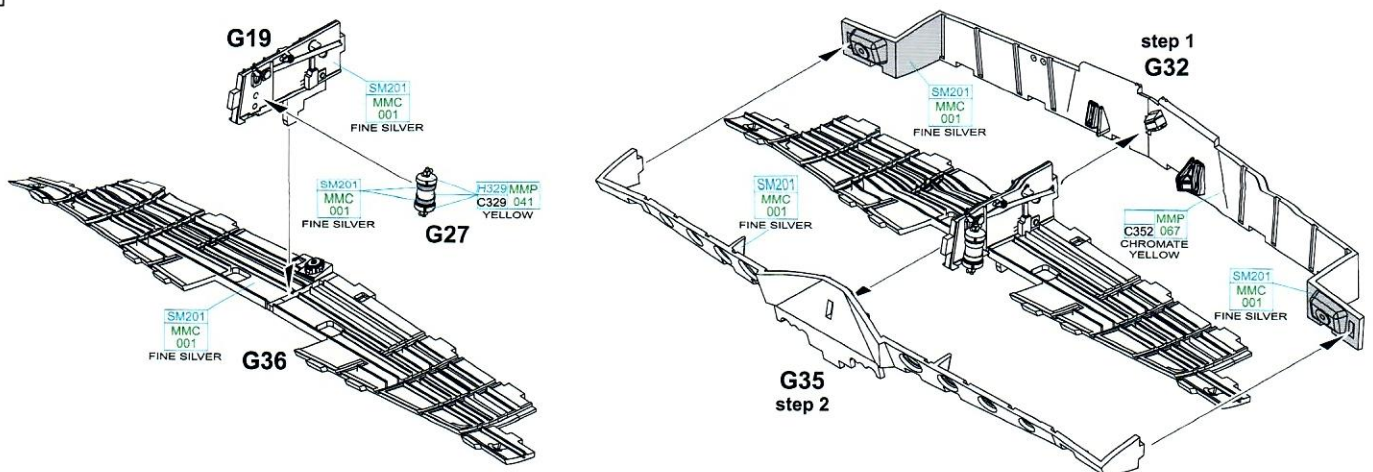
D**E**

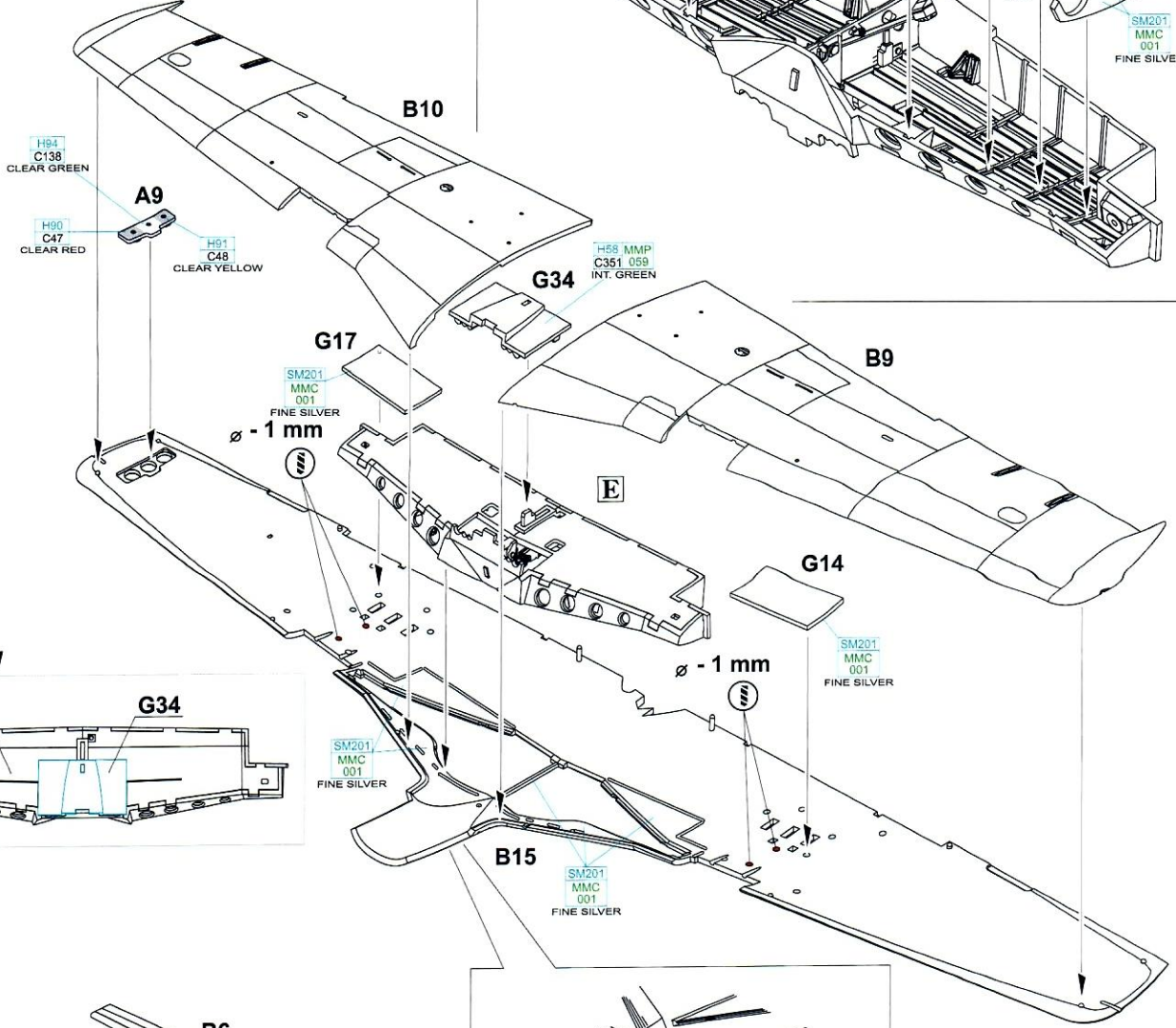
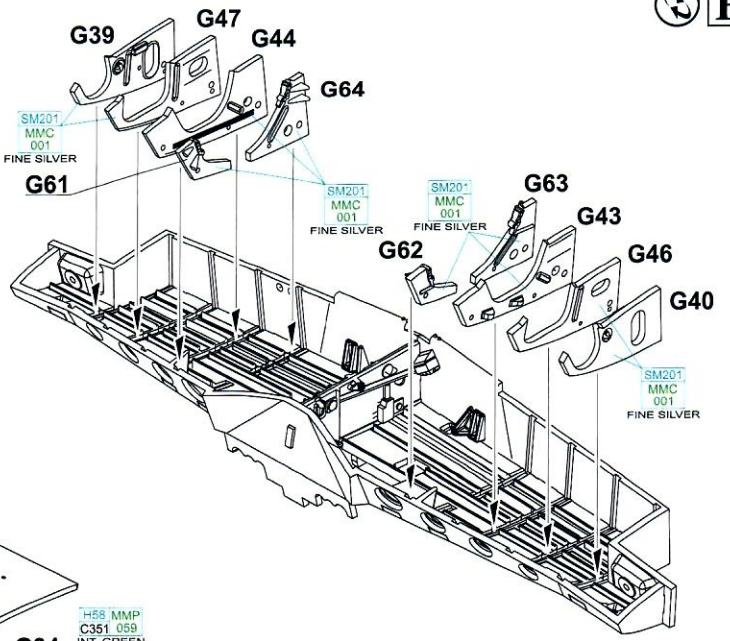
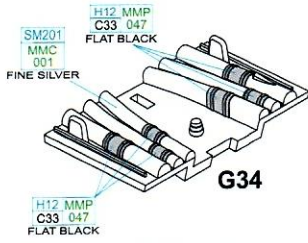

UPPER VIEW

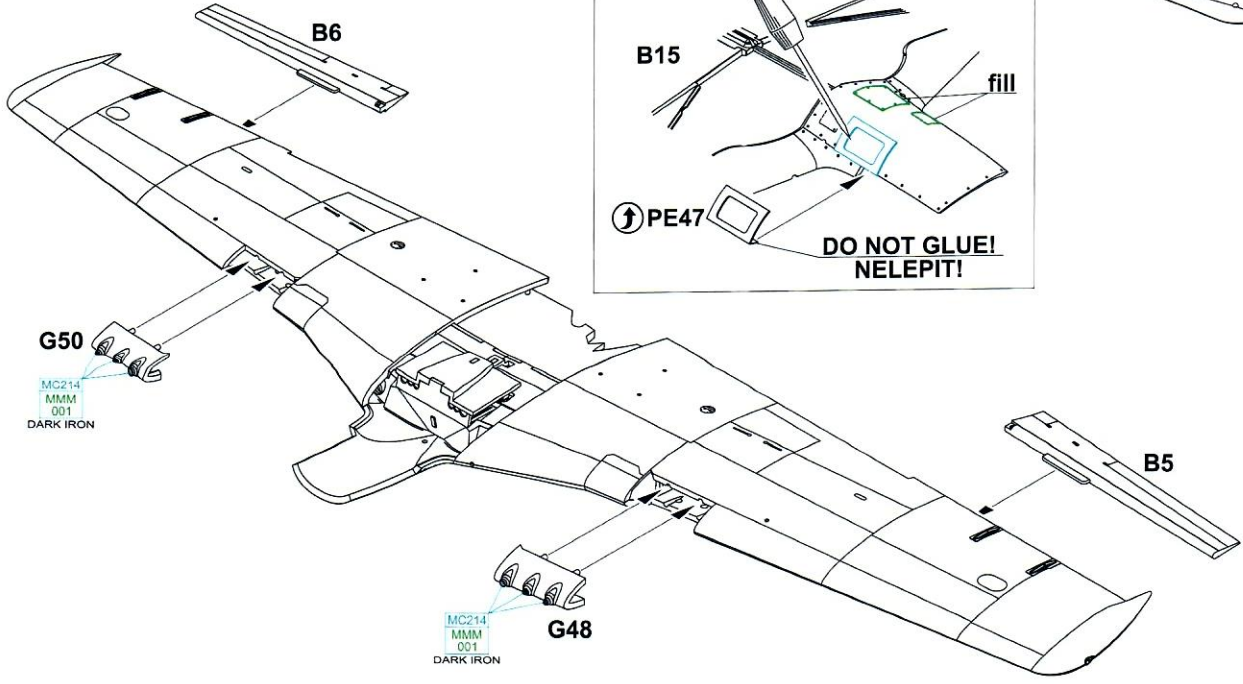
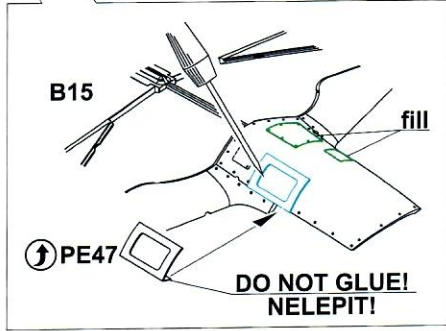
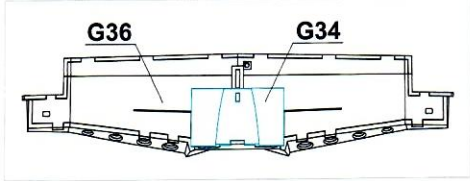

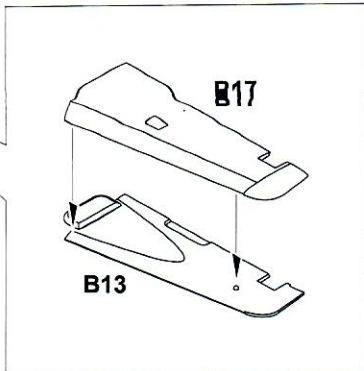
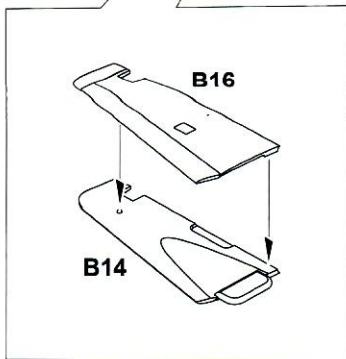
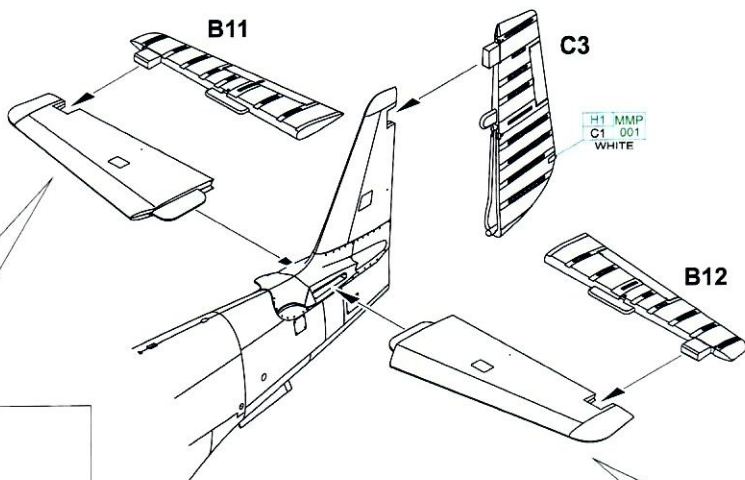
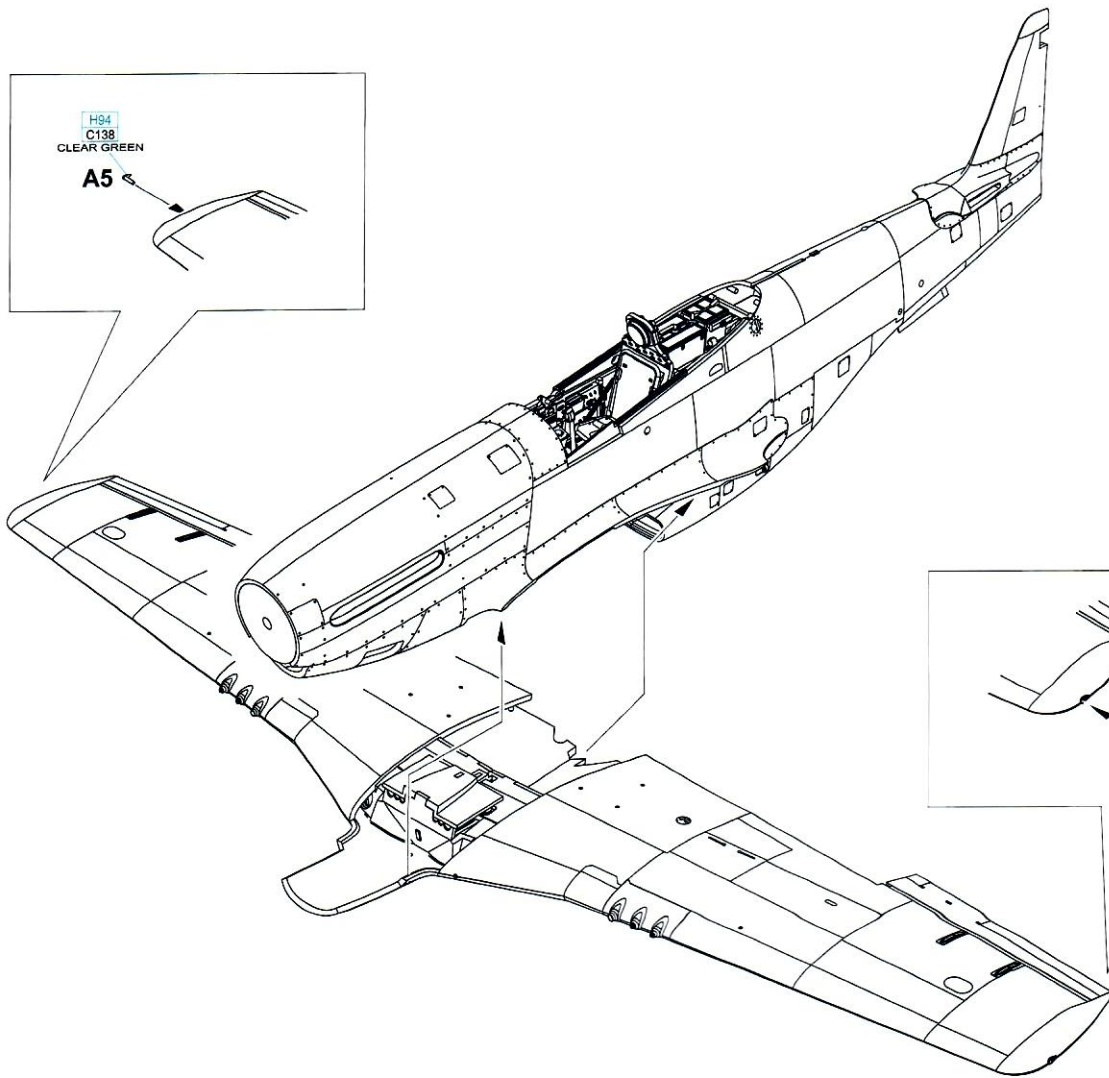
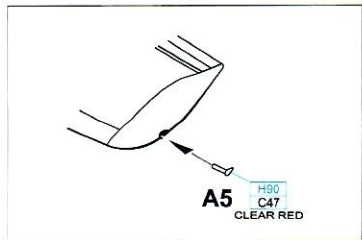
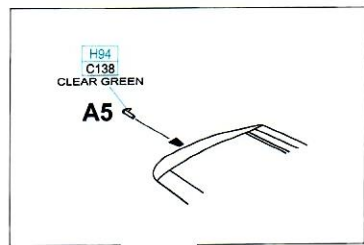

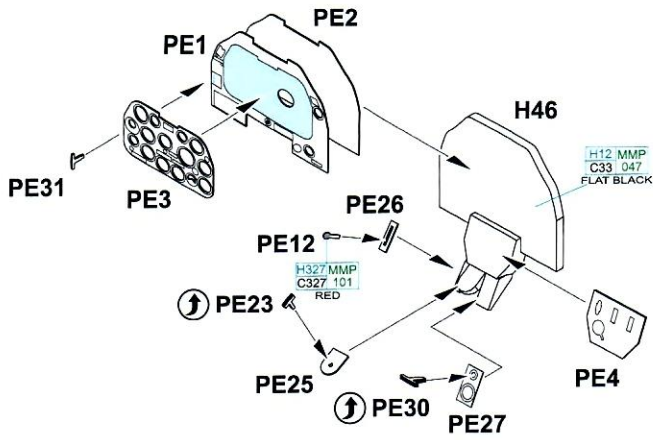

A8 right (A7 left)

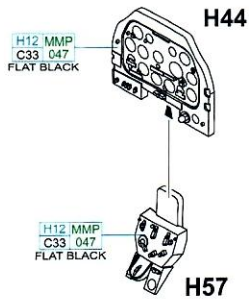
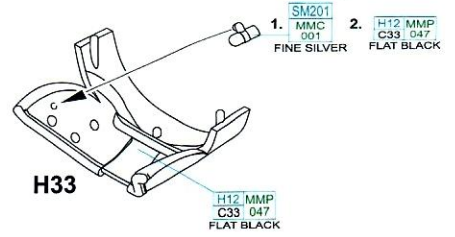

OPTIONAL:
decal 61, 62,
63, 64, 65

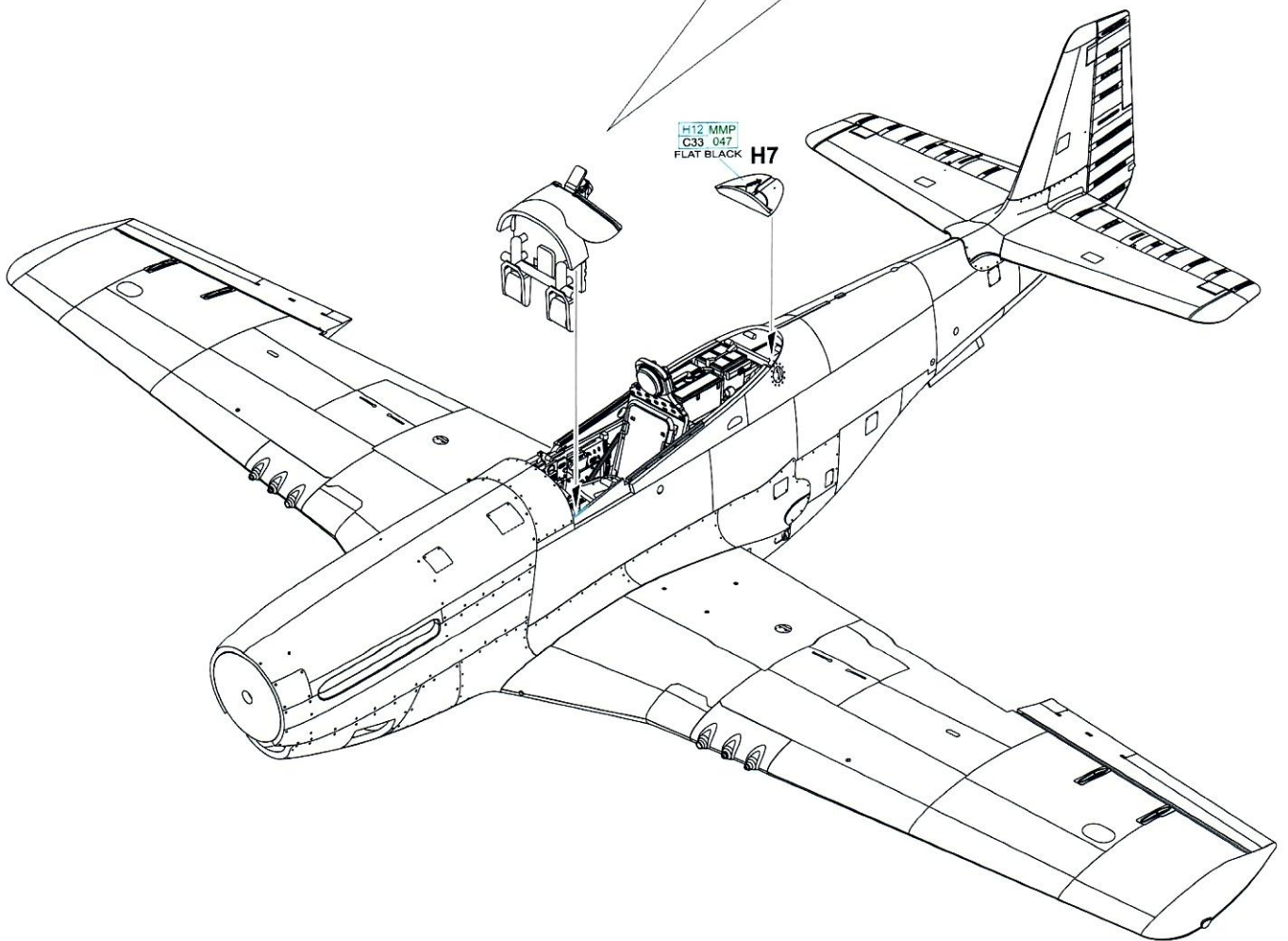
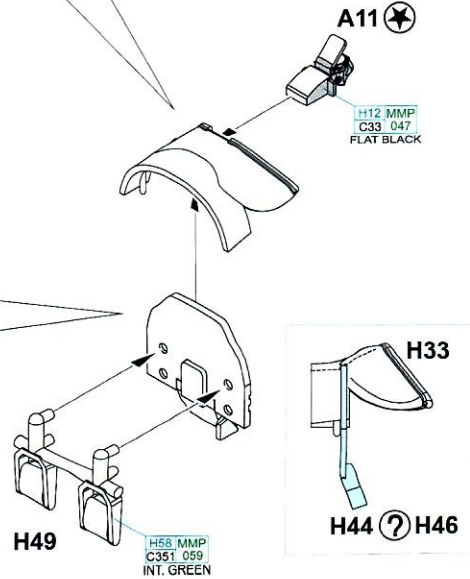
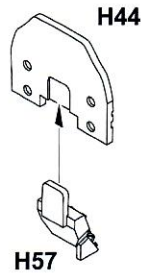

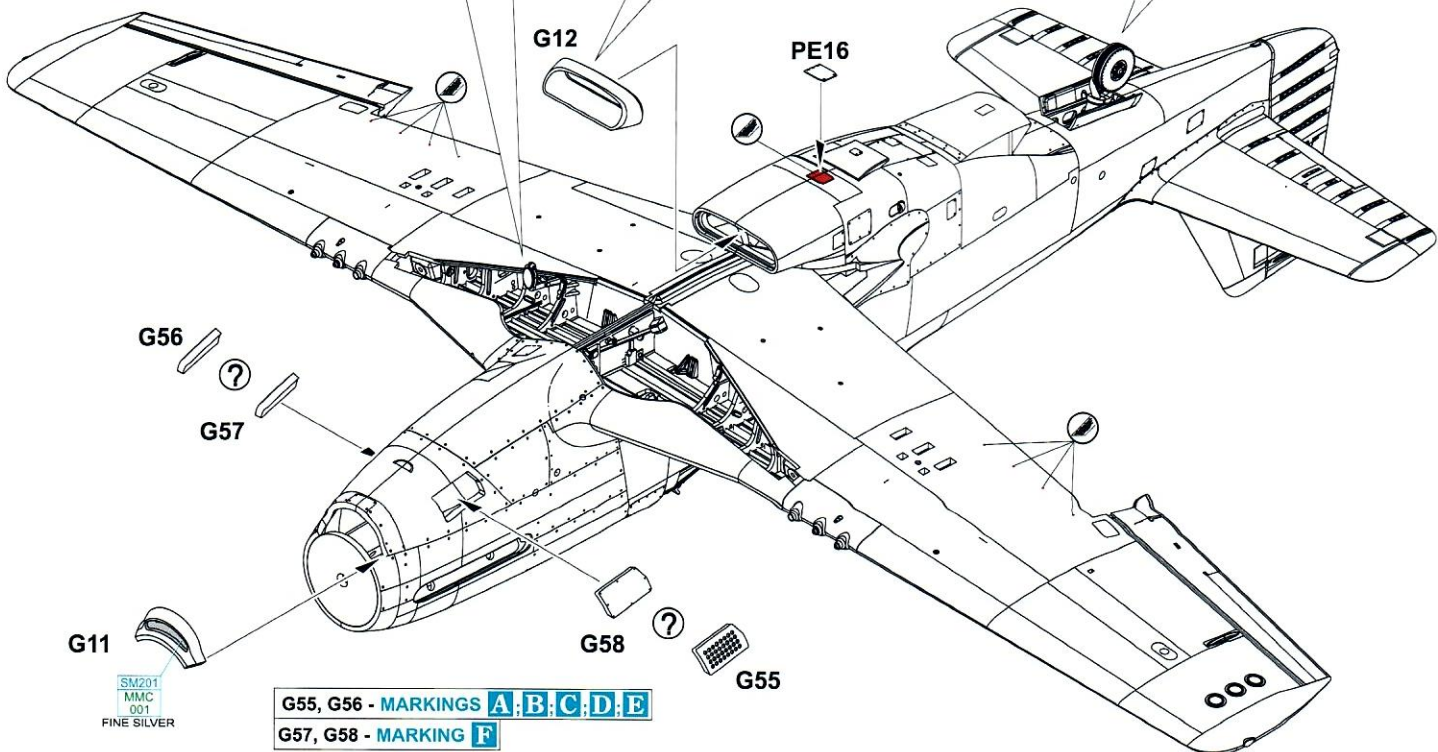
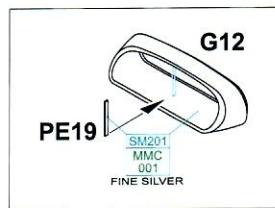
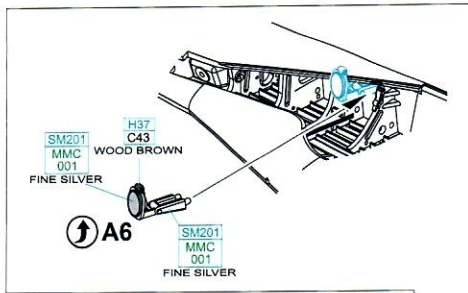
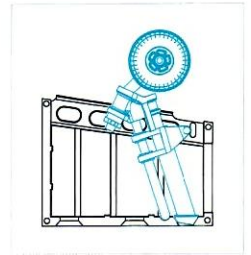
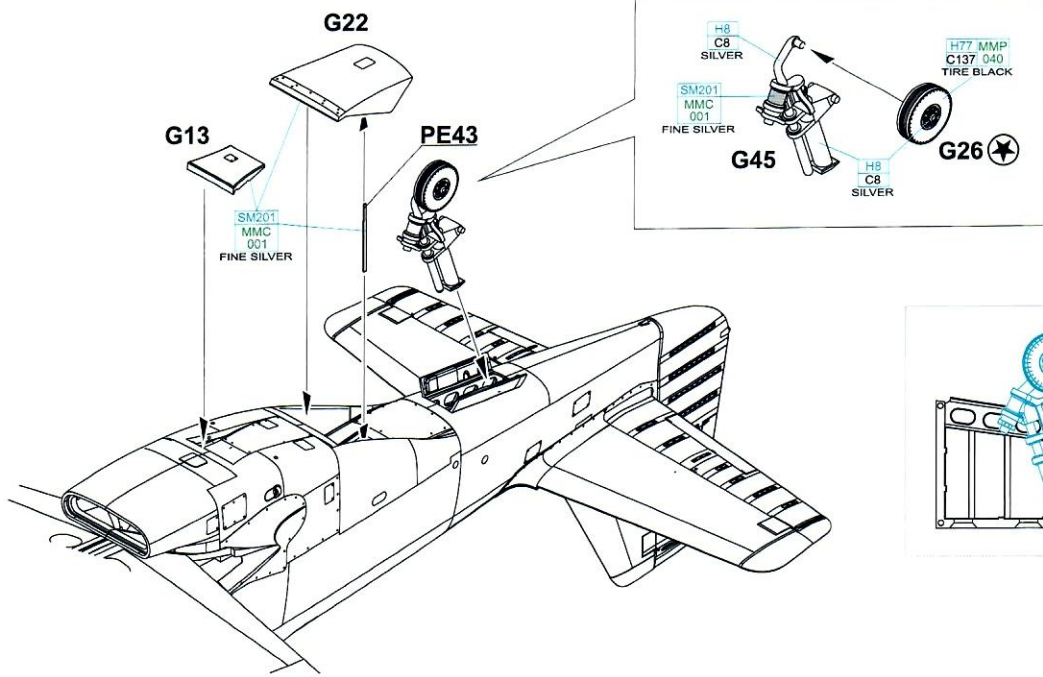

G55, G56 - MARKINGS **A, B, C, D, E**
 G57, G58 - MARKING **F**

step 1 - G37, G38
step 2 - G24, G25

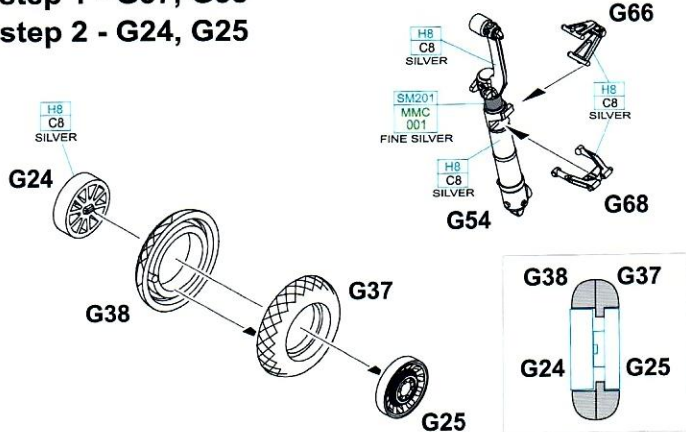

step 1 - G37, G38
step 2 - G24, G25

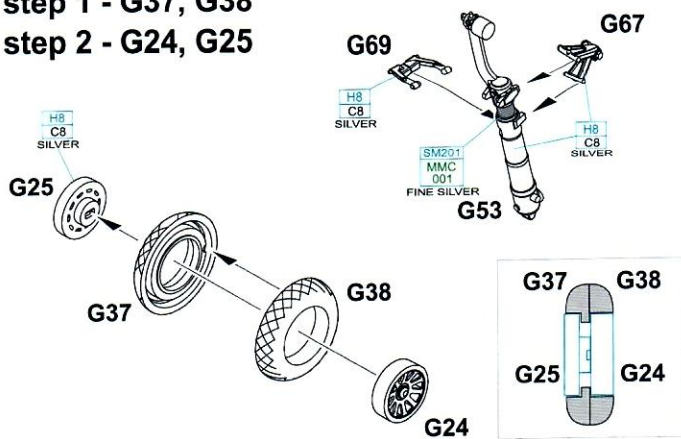

F

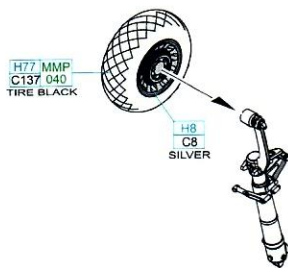

G

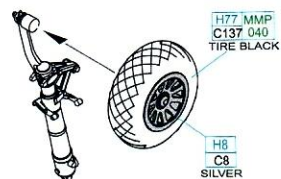

H

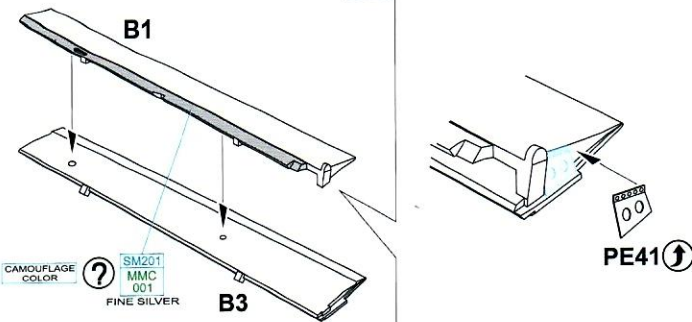

CAMOUFLAGE COLOR - MARKING A ONLY

I

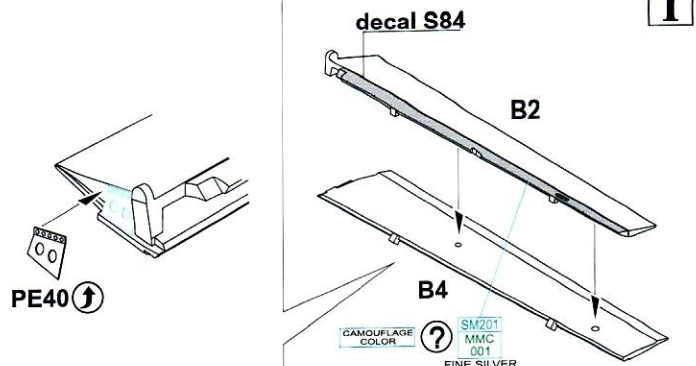

CAMOUFLAGE COLOR - MARKING A ONLY

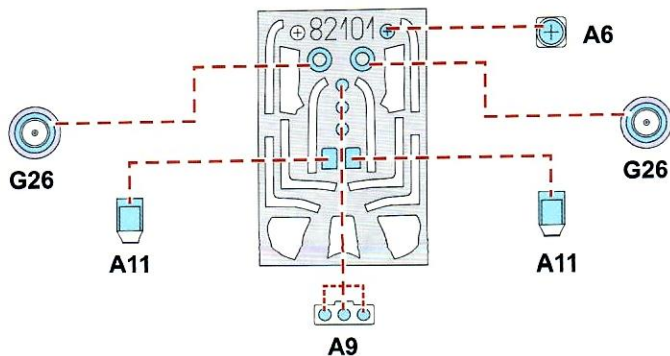
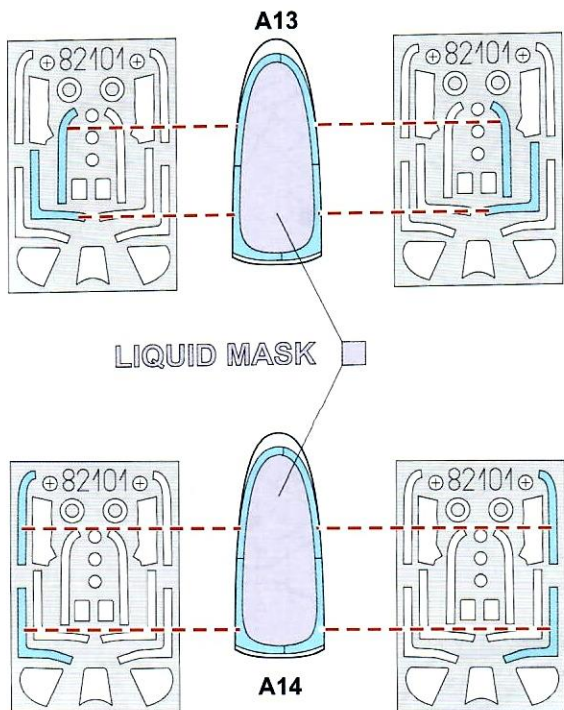

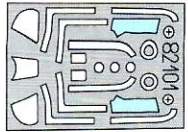
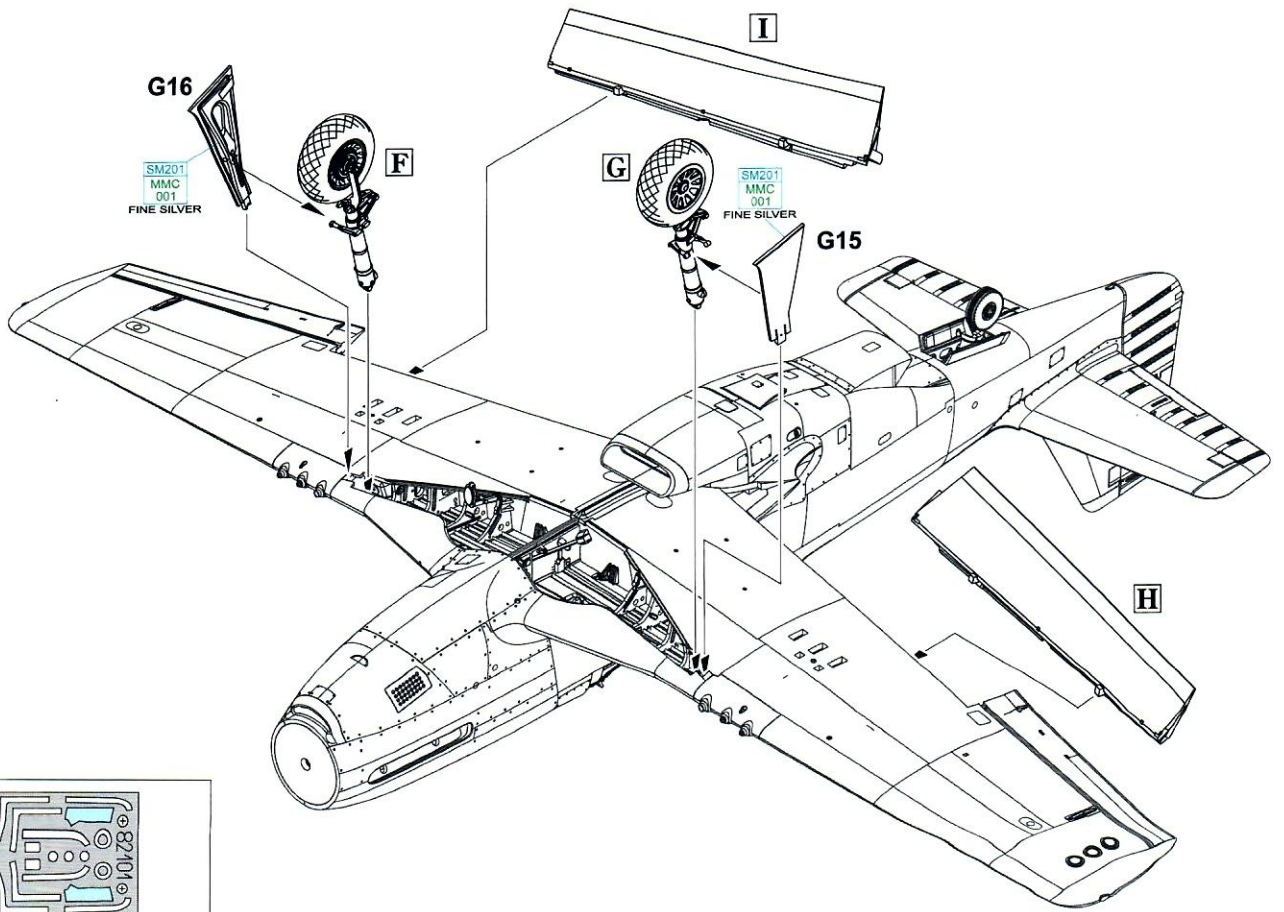

G33 → G31

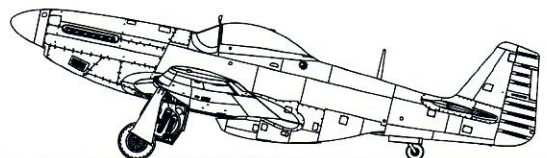
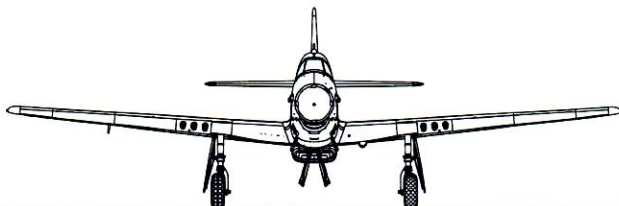
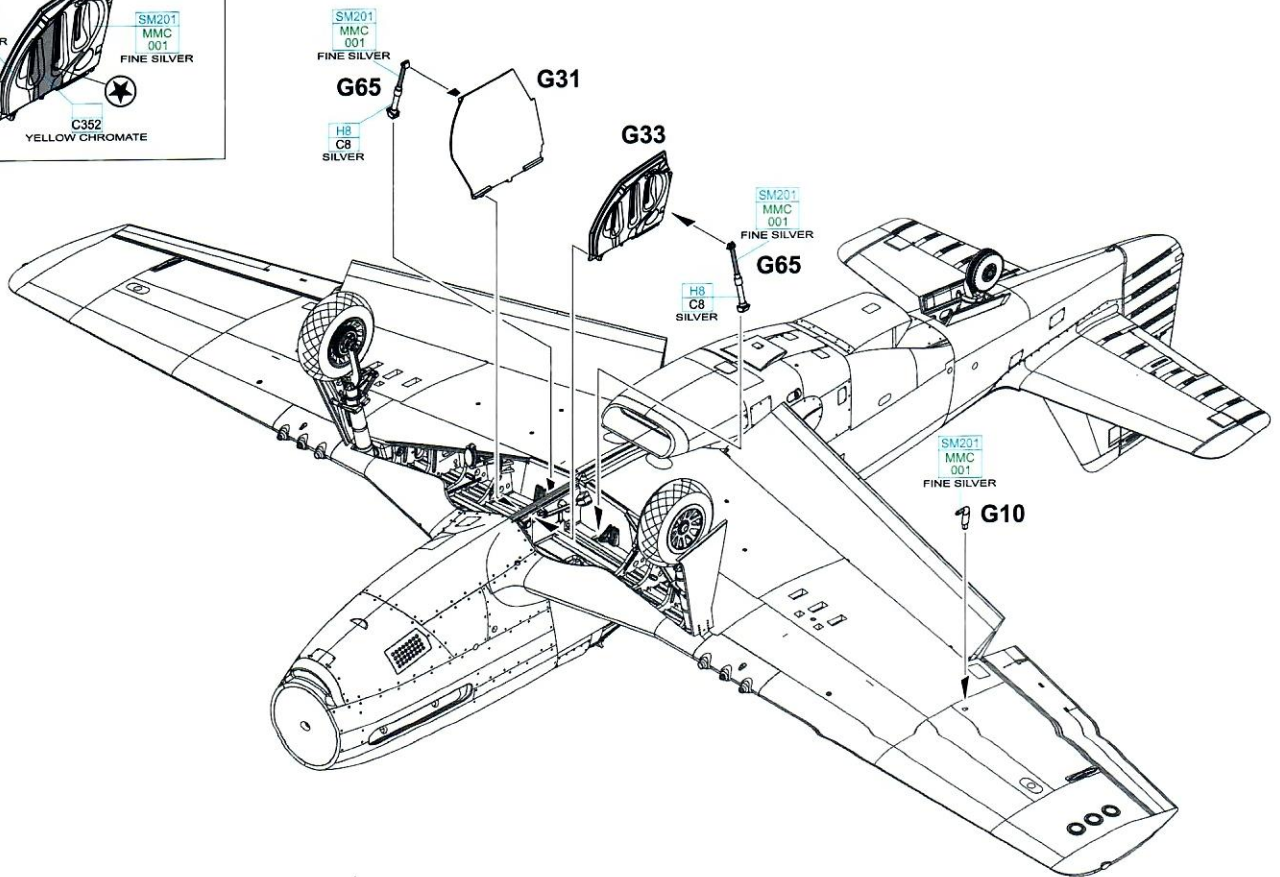
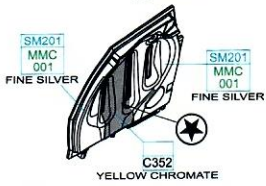

2 pcs.

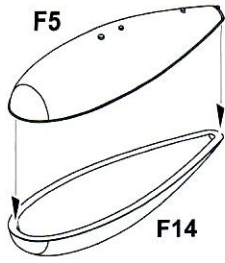

2 pcs.

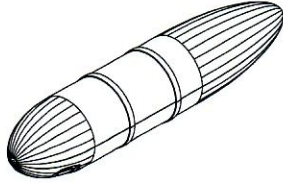
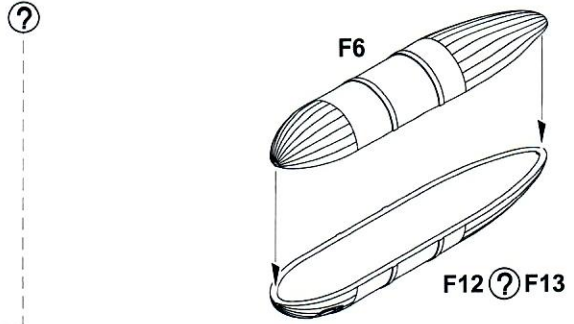

?

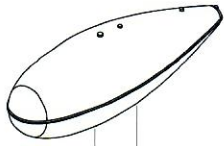
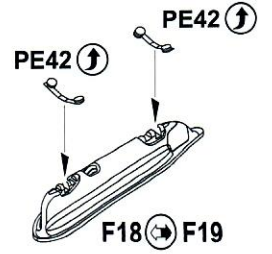

F19

H12 MMP ? H8
C33 047 C8
FLAT BLACK SILVER

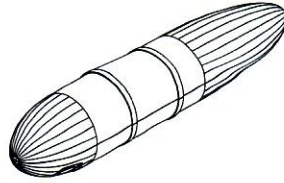

?

H12 MMP - MARKINGS A, F ONLY
C33 047
FLAT BLACK

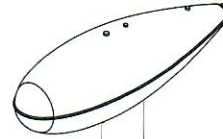

H12 MMP ? H8
C33 047 C8
FLAT BLACK SILVER

F18

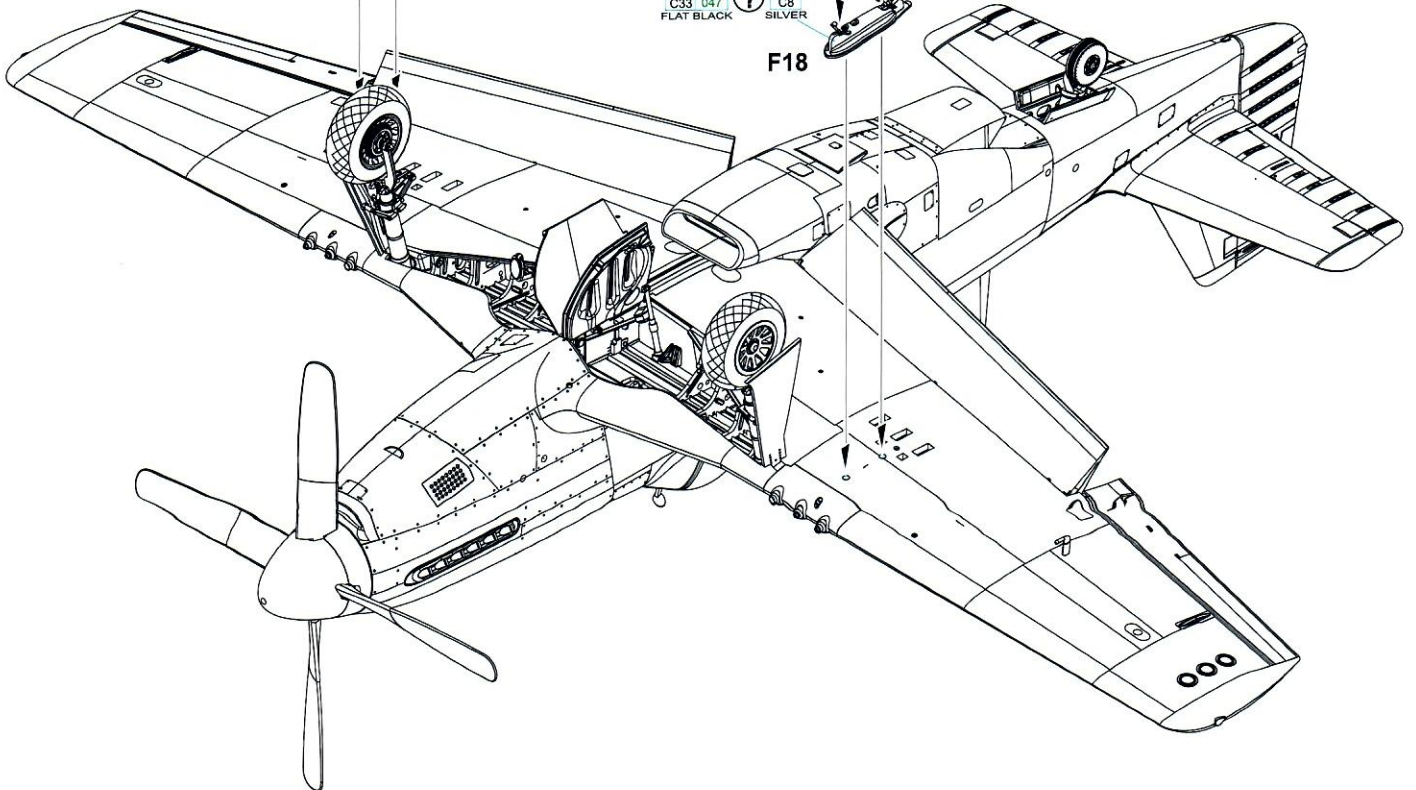

A s/n 44-13318, Lt.Col. Thomas L. Hayes Jr., CO of 364th FS, 357th FG, 8th AF, Leiston, United Kingdom, August 1944

Thomas L. Hayes was born on March 31, 1917, in Portland, Oregon and after his studies at the Oregon State College he enlisted in the USAAF. After the training he was assigned to 35th PG where he was flying P-40 defending Java against Japanese forces. After being wounded in combat with Zeros of 3 Kōkūtai on February 20, 1942, he was dispatched to New Guinea. There, he was assigned to 41st PS flying Airacobras. In the fall of 1942, Thomas Hayes was sent back to the USA where, in May 1943, he was assigned to 357th FG with which he completed the advanced training. Already in command of 364th FS, he was sent to Great Britain where he flew combat missions until August 11, 1944, when he was sent back to the United States. During the World War II he was credited with 8.5 aerial kills. After the World War II he remained in the service with the USAF and retired in February 1970 in the rank of Brigadier General. Lt. Col. Hayes' aircraft carried inscription *Frenesi* on the nose port side after the then popular song *Free 'n Easy*. Number of missions was depicted in form of 85 little bombs painted above the exhaust stacks. It remains unclear which camouflage paint were used on the 357th FG aircraft. Some veterans speak of the British colors Dark Green and Medium Sea Gray, surviving color photographs indicate American Olive Drab and Neutral Grey colors theory. Noses of the 357th FG aircraft were decorated with yellow-red checkerboard, propeller spinner was painted in the same colors.

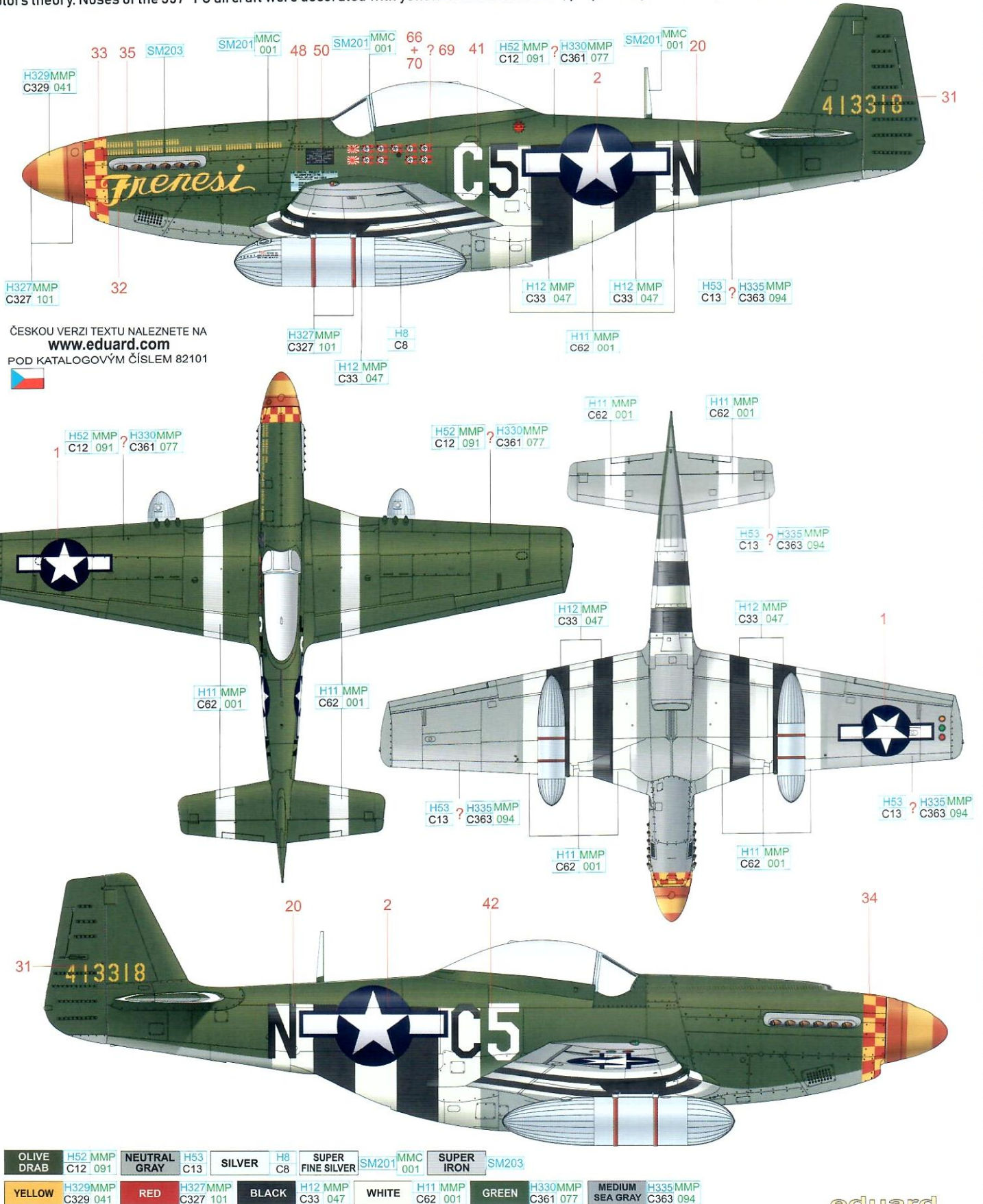

Twenty-four years old native of Monroe in Louisiana, Claude James Crenshaw, joined the ranks of the Army Air Corps in December 1942. After his training he was assigned to 359th FG based on East Wretham in Great Britain. He completed nine-months long tour of duty there, during which he shot down seven enemies. After that, he was ordered back to the United States where he was flying as instructor. He also flew combat in Korea and Vietnam retiring in 1965 with the rank of Lieutenant Colonel. The aircraft flew in its original factory finish. The green-painted nose was 359th FG marking the plane's so-called invasion stripes on the fuselage and wings were already removed as well as the black stripe painted on the vertical tail surface and the rudder.

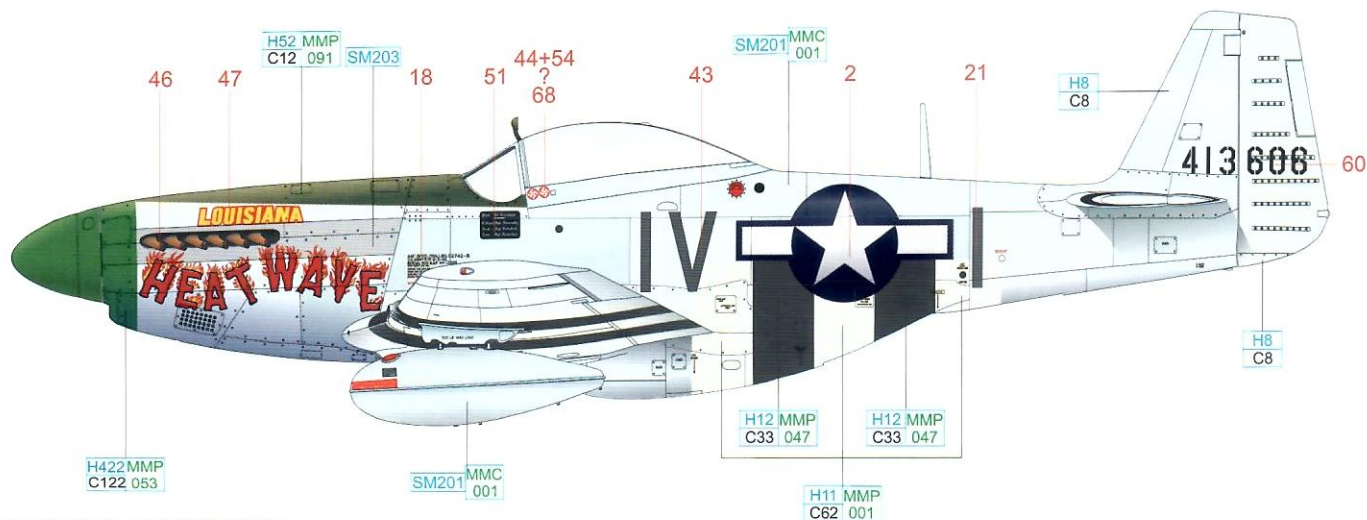

ČESKOU VERZI TEXTU NALEZNETE NA
www.eduard.com
 POD KATALOGOVÝM ČÍSLEM 82101

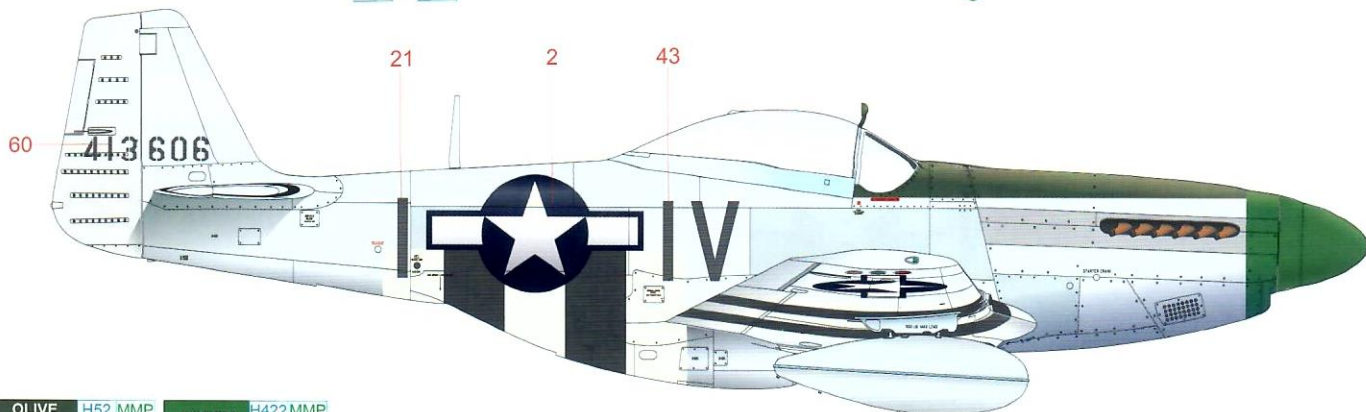
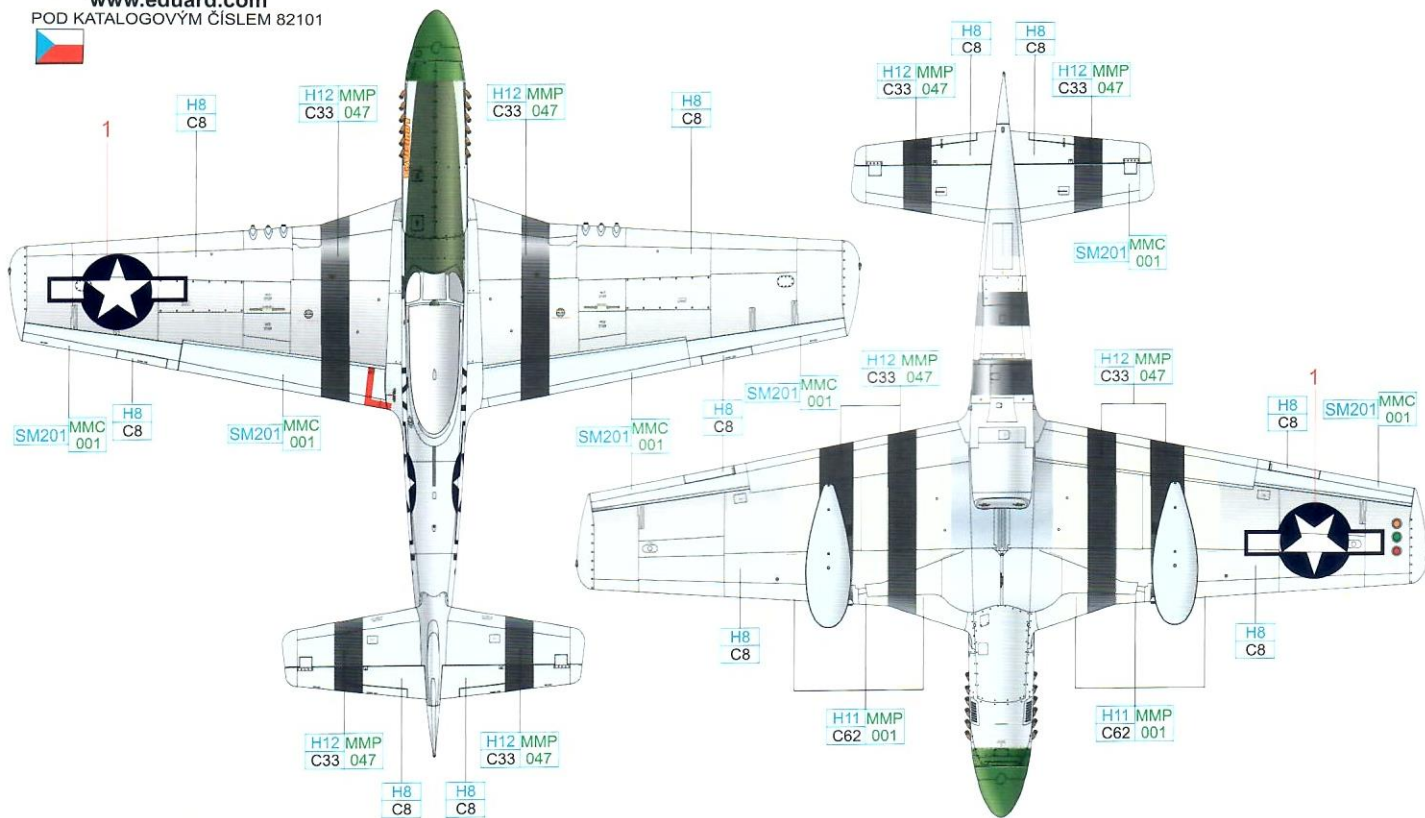

OLIVE DRAB	H52 MMP C12 091	GREEN	H422 MMP C122 053
BLACK	H12 MMP C33 047	SILVER	H8 C8
		SUPER FINE SILVER	SM201 MMC 001
		SUPER IRON	SM203

Besides decorating the aircraft with girlfriend's, children's or wife's names, drawings of the sparsely clad ladies decorated some aircraft noses as well. Its artistic appearance depended on the ground personnel skills, if any could be found at the unit level. One of the Mustangs that sported the "pin up girl" artwork was the aircraft belonging to 55th FS flown by Lt. Mullins. Factory finish was supplemented with the olive color coat on the fuselage and wings upper surfaces. 55th FS affiliation is further confirmed by the fuselage code KI as well as the black triangle on the vertical tail surface and the rudder carrying the plane's individual letter in white color.

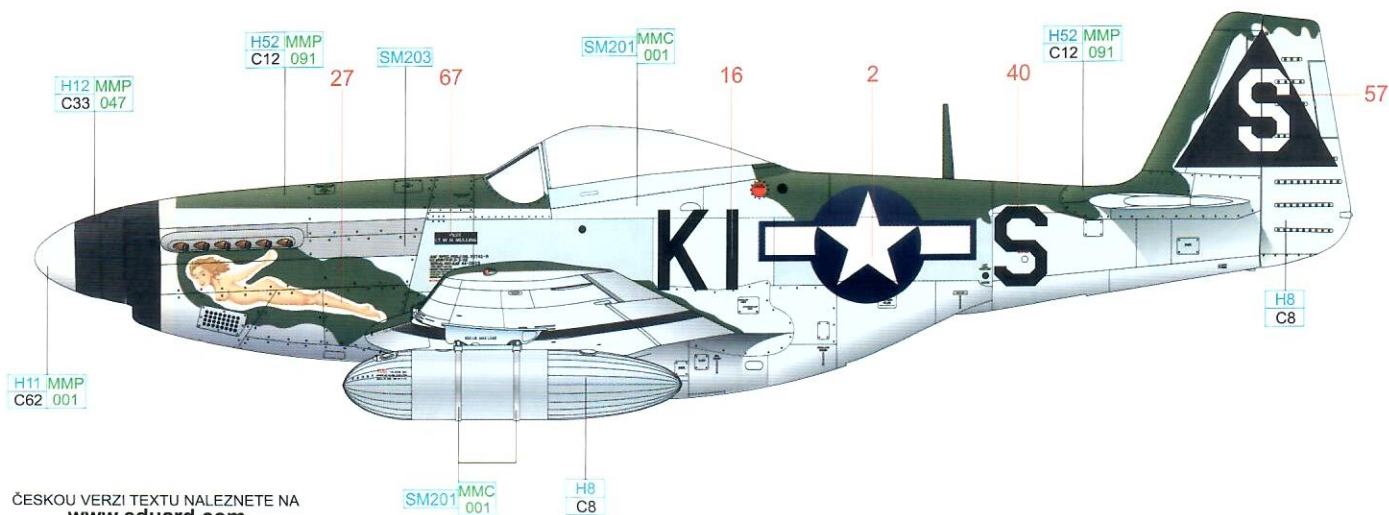

ČESKOU VERZI TEXTU NALEZNETE NA www.eduard.com POD KATALOGOVÝM ČÍSLEM 82101

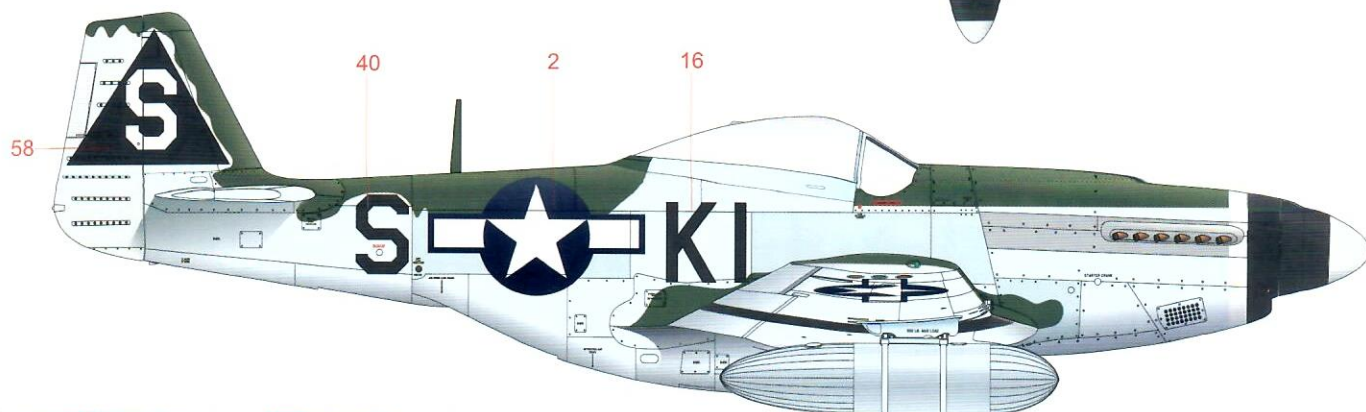
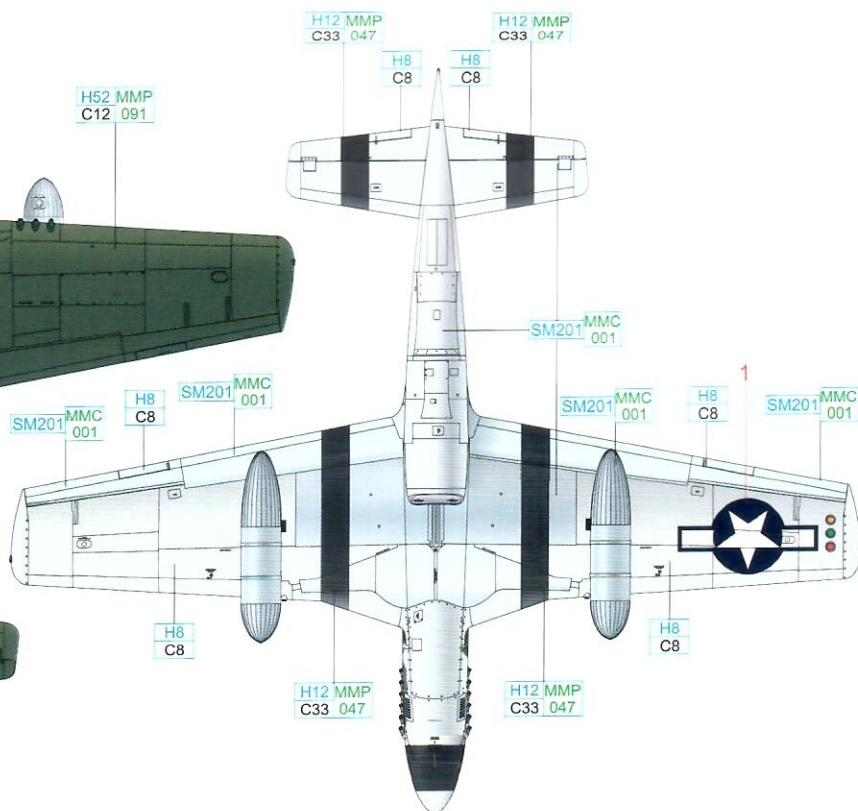
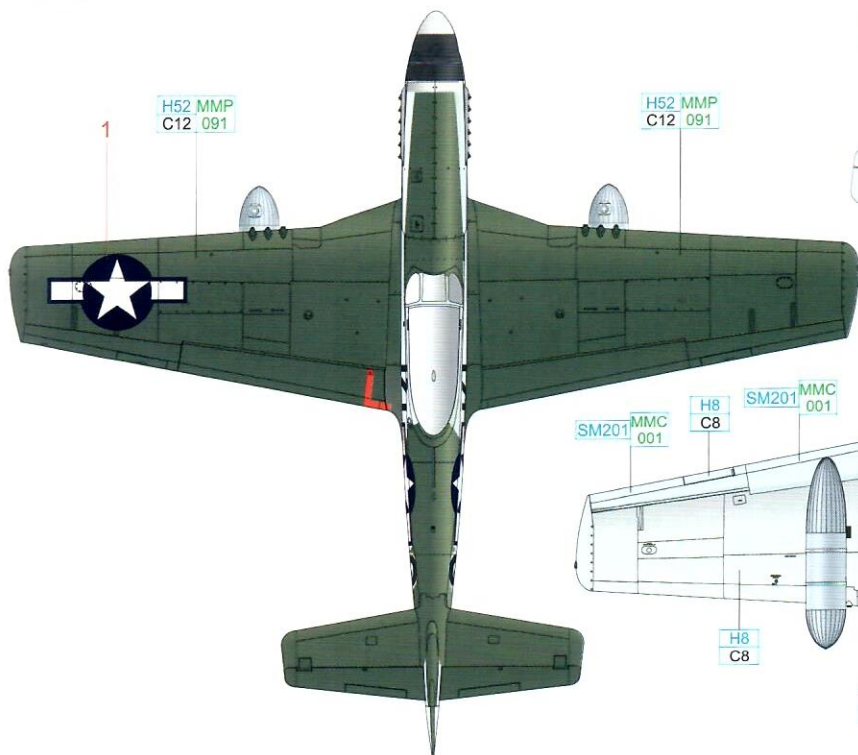

SILVER	H8 C8	SUPER FINE SILVER	SM201 MMC 001	SUPER IRON	SM203
OLIVE DRAB	H52 MMP C12 091	BLACK	H12 MMP C33 047	WHITE	H11 MMP C62 001

John Mack Simmons, native of Gadsden in Alabama, joined army reserves in June 1942 and in January 1943 started his pilot's training. After the graduation he was dispatched to 317th FS in the Italian theater. From the second half of April, he flew P-47s with this unit, in May, the whole 325th FG was re-equipped with superior Mustangs. While flying combats during the World War II, John Simmons shot down seven enemy aircraft and after it he remained in the USAF service. On January 18, 1961, he perished in the T-33 crash during the final approach. Since their African assignment the 325th FG aircraft were marked with yellow-black checkerboard painted on the tail surfaces to distinguish them from the bombers they covered and which gave them the nickname "Checkertails". The checkers' dimensions were 10 by 10 inches. The plane marked with number 27 carried the inscription "Devastating Dottie" on the port side of the nose, the starboard side sported the name "Lady Janie VIII" as all the aircraft of crew chief Ebert.

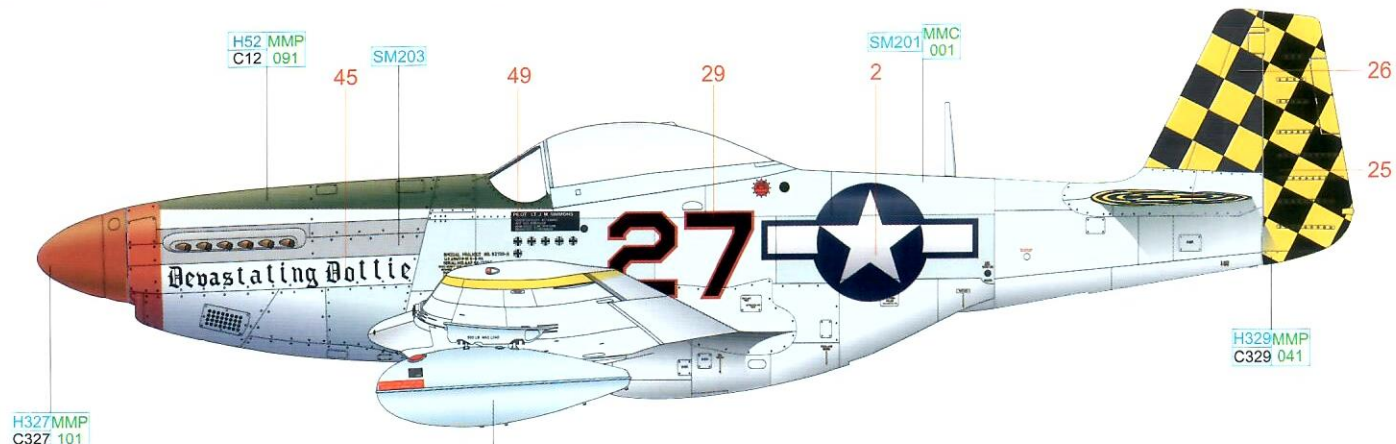

ČESKOU VERZI TEXTU NALEZNETE NA
www.eduard.com
POD KATALOGOVÝM ČÍSLEM 82101

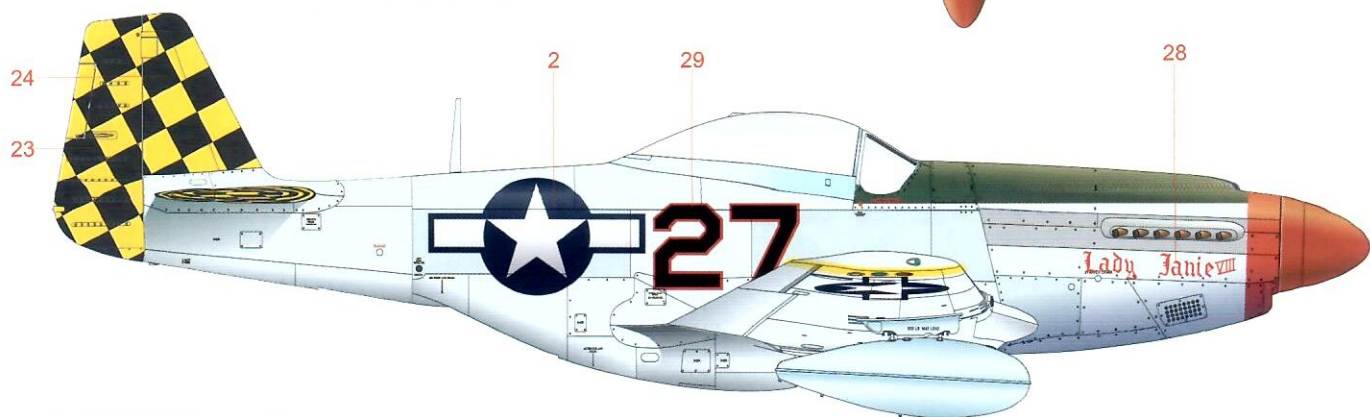
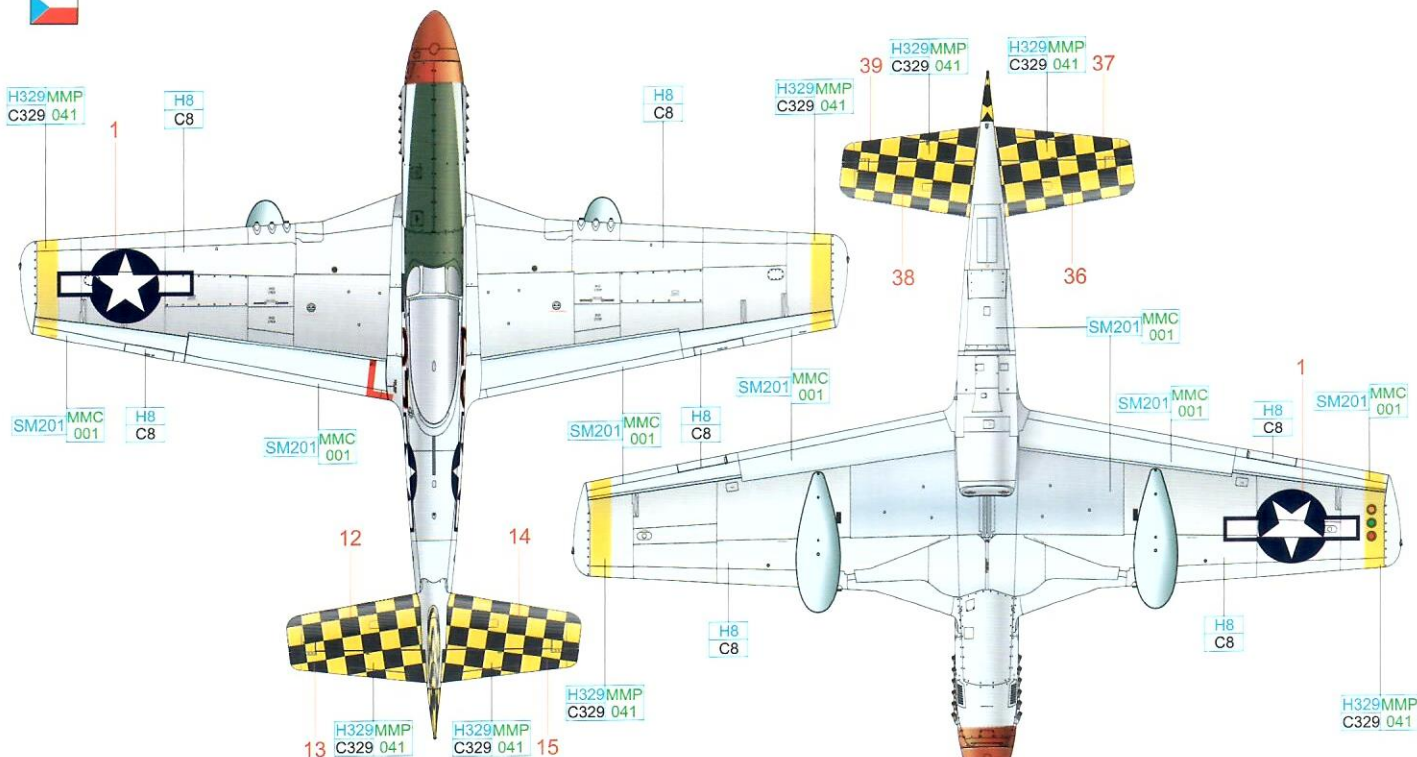

SILVER	H8 C8	SUPER FINE SILVER	SM201 MMC 001	SUPER IRON	SM203
OLIVE DRAB	H52 MMP C12 091	YELLOW	H329 MMP C329 041	RED	H327 MMP C327 101

The future fighter ace with the highest score among all the pilots achieved on Mustang was born on February 5, 1919, in Greensboro, North Carolina. He had completed the pilot training before the War and tried three times to enlist in the US Navy in 1940. But he was refused every time. Fourth time he tried to enlist in the USAAC and was accepted in 1940. He completed the fighter training consequently and, assigned to 49th PS, was dispatched to Australia. Flying P-40E in the defense of Darwin he was credited with two Japanese airplanes damaged. In July 1942, after the mid-air collision during the training flight, he was wounded and sent back to the United States. As of September 1943, his next combat assignment awaited him in Europe with 352nd FG, where he was flying P-47 Thunderbolts providing cover for heavy bombers of the 8th AF. In April, the unit converted to P-51 Mustangs. In June, the war photographer snapped Maj. Preddy's aircraft sporting seventeen kills painted on the aircraft nose in the form of the white crosses. The aircraft lacked any camouflage and sported the blue-painted nose, same as other 352nd FG aircraft. The fuselage and wings were still carrying so-called invasion stripes.

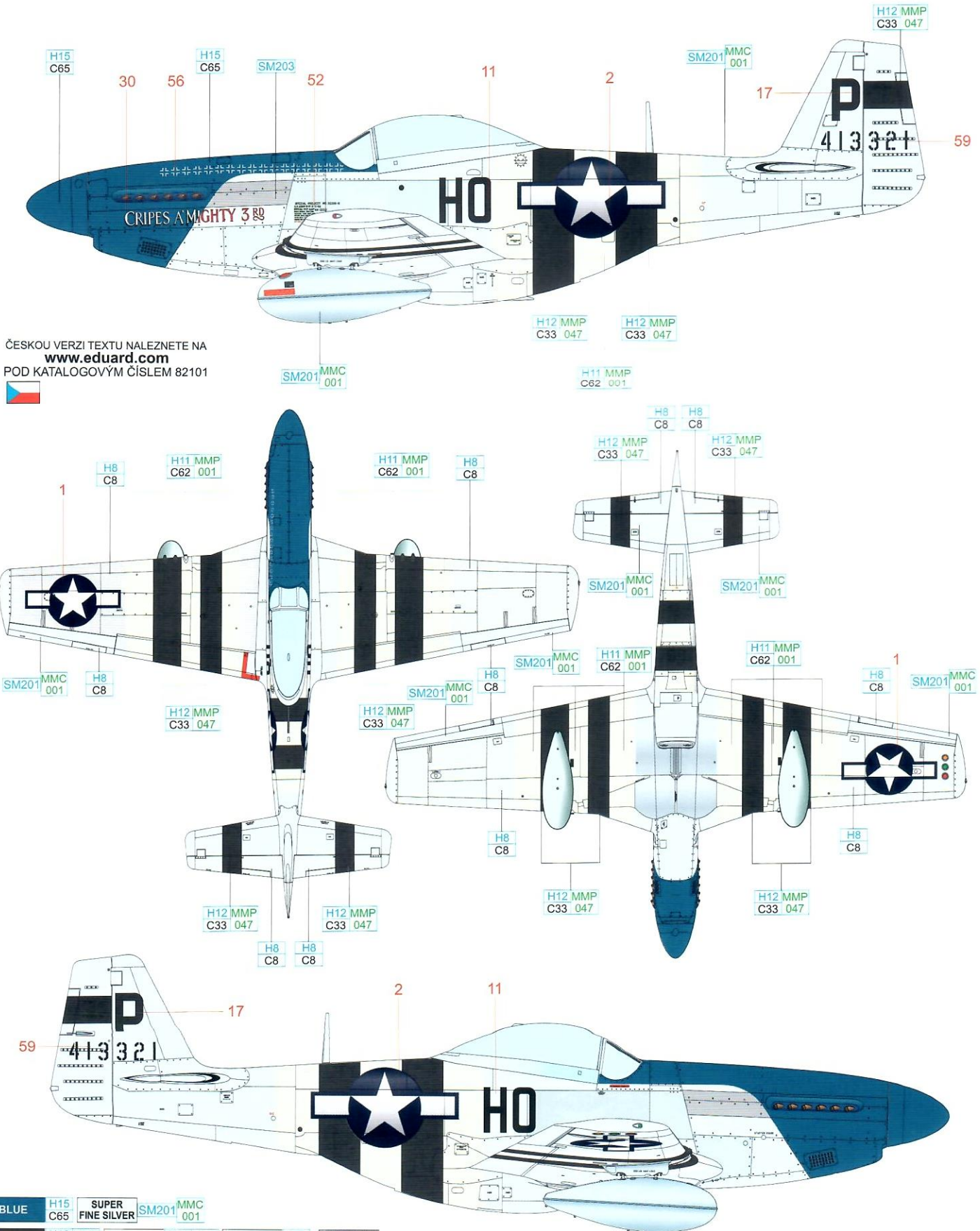

ČESKOU VERZI TEXTU NALEZNETE NA
www.eduard.com
 POD KATALOGOVÝM ČÍSLEM 82101



BLUE	H15 C65	SUPER FINE SILVER	SM201 MMC 001
BLACK	H12 MMP C33 047	WHITE	H11 MMP C62 001
		SILVER	H8 C8
		SUPER IRON	SM203

In the photography taken at the end of July, there are already 23 kill marks painted on Preddy's aircraft nose. The plane was already missing invasion identifying stripes on the upper side of the wing, they remained on the bottom of the wing and fuselage. While removing these, the European theater markings of 15-inch wide stripes on the upper side of the wing and horizontal tail surfaces, as well as 12 inch stripe on the vertical tail surface were deleted as well. The pilot's name tag was added to the canopy frame. In August 1944, Maj. Preddy was sent back to United States for a rest. After his return in October the same year he took command of 328th FS, part of 352nd FG. On December 25, in vee hours when chasing Fw 190 over the front line was Preddy's Mustang hit by the American anti-aircraft fire. He attempted the emergency landing nearby the anti-aircraft battery but he was fatally wounded and crashed in its vicinity.

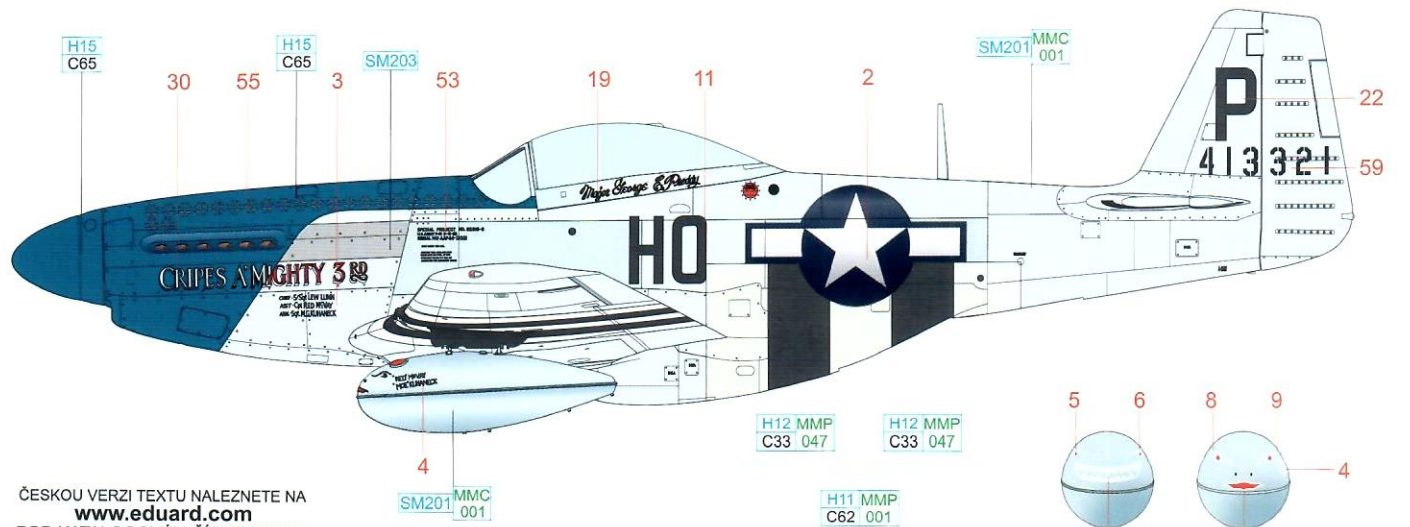

ČESKOU VERZI TEXTU NALEZNETE NA www.eduard.com POD KATALOGOVÝM ČÍSLEM 82101

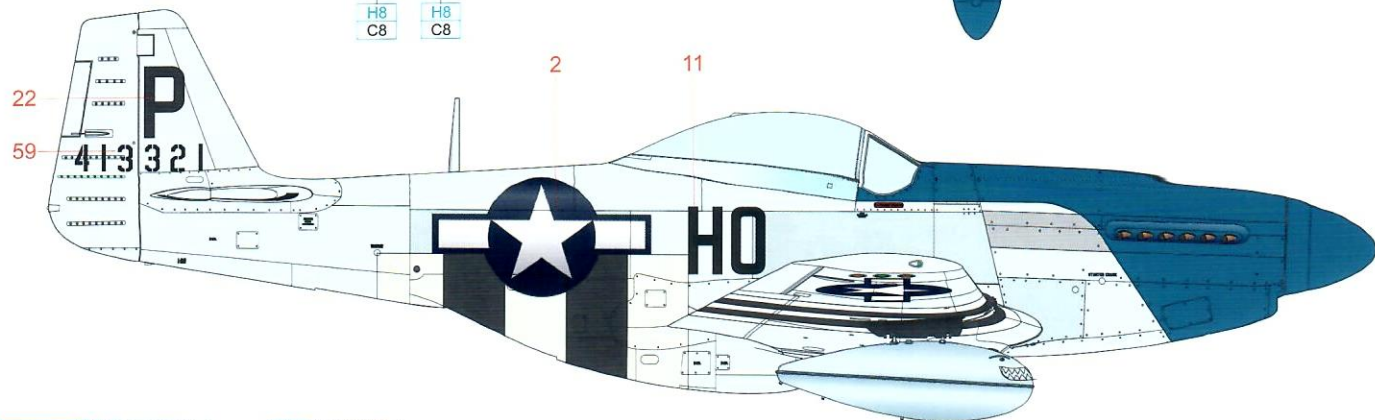
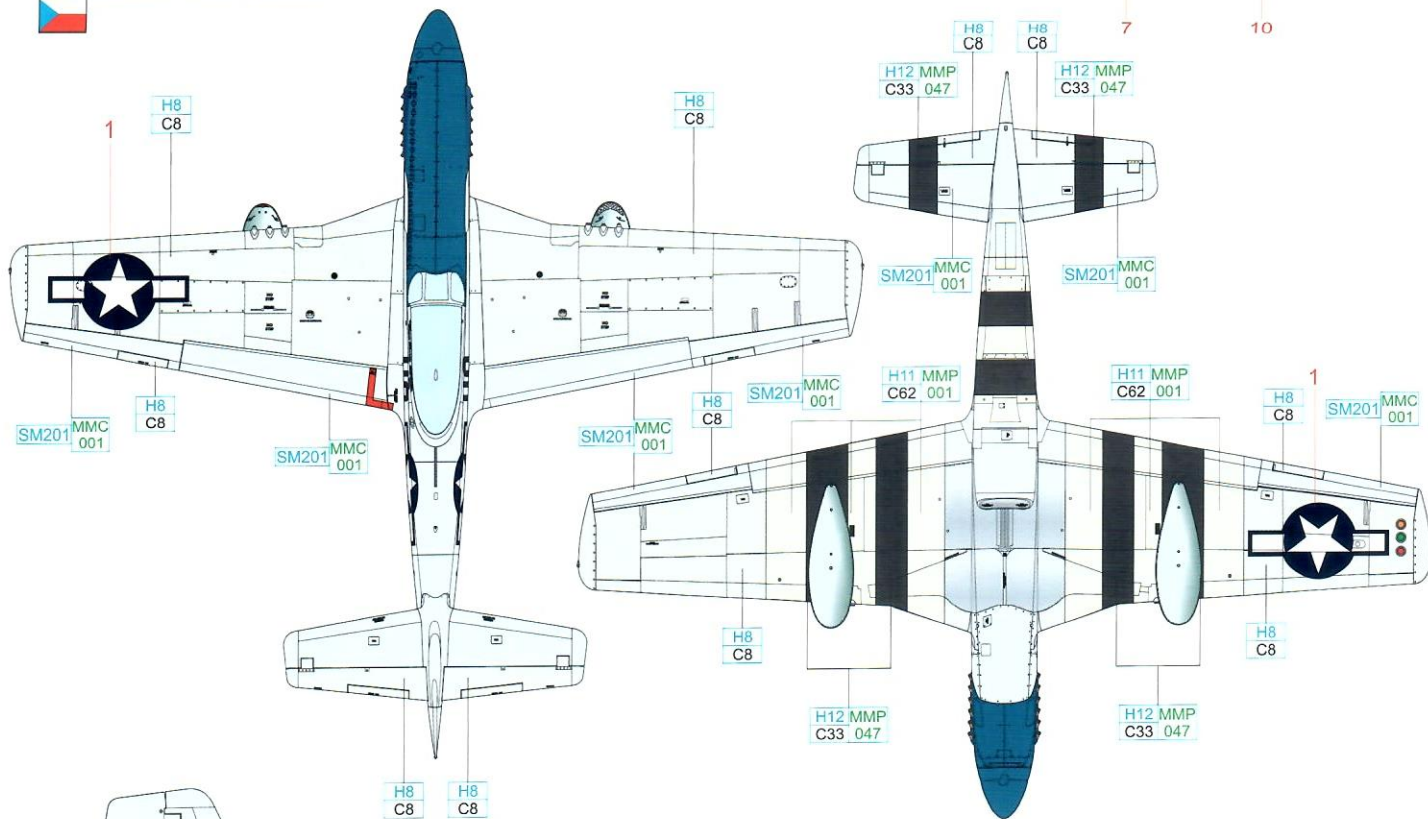

BLUE	H15 C65	SUPER FINE SILVER	SM201 MMC 001	SUPER IRON	SM203
BLACK	H12 MMP C33 047	WHITE	H11 MMP C62 001	SILVER	H8 C8

P-51D-5 ALUMINIUM LACQUER PAINTED AREAS

