

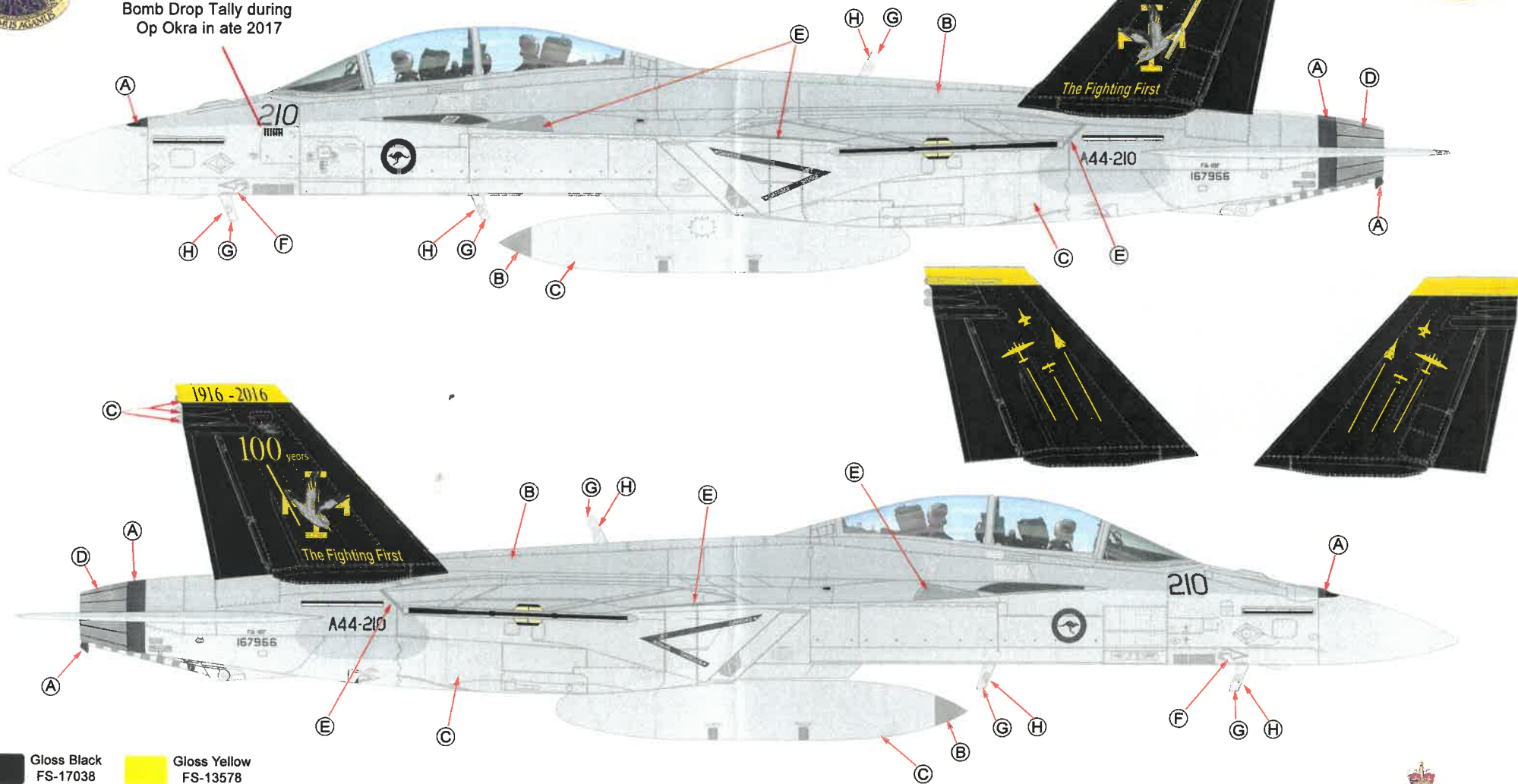

Royal Australian Air Force 1 Squadron 100th Anniversary 1916 - 2016



Bomb Drop Tally during
Op Okra in late 2017



Gloss Black
FS-17038 Gloss Yellow
FS-13578

Drawings by Steven Evans ©Copyright 2016

Reference:
RAAF Website.
www.adf.gov.au
+Personal Pics

(A) Steel

(C) (Lower Surface)
Light Ghost Grey
FS-36375

(E) (Leading/trailing edges wing only)
Dark Ghost Grey FS-36320
+ 5% Medium Grey FS-35237

(I) (Leading and trailing edges of tail only)
Light Ghost Grey FS-36375
+ 5% Medium Grey FS-35237

(B) (Upper Surface)
Dark Ghost Grey
FS-36320
+ 5% white (Top Fades Fast)

(D) Burnt Iron

(F) Silver

(G) White

(H) Matt Linen (Leading edges of antenna's)
Hum 74



The RAAF Roundel, Squadron Markings and Badges
have been reproduced under license and with permission
and approval of the Royal Australian Air Force

RDS-158 RAAF 1 Squadron 100th Anniversary 1916-2016

All Squadron Crests, Shields and
Roundels are Crown Copyright.

PRINTED AND DESIGNED BY:
RONITH GRAPHICS AUSTRALIA
AUSTRALIAN MADE AND OWNED

Note: Lighter text (Data) goes on the upper surface (Darker surface) and the darker text (Data) goes on the lower (Lighter surface)

This set is designed for the RAAF Super Hornets only.

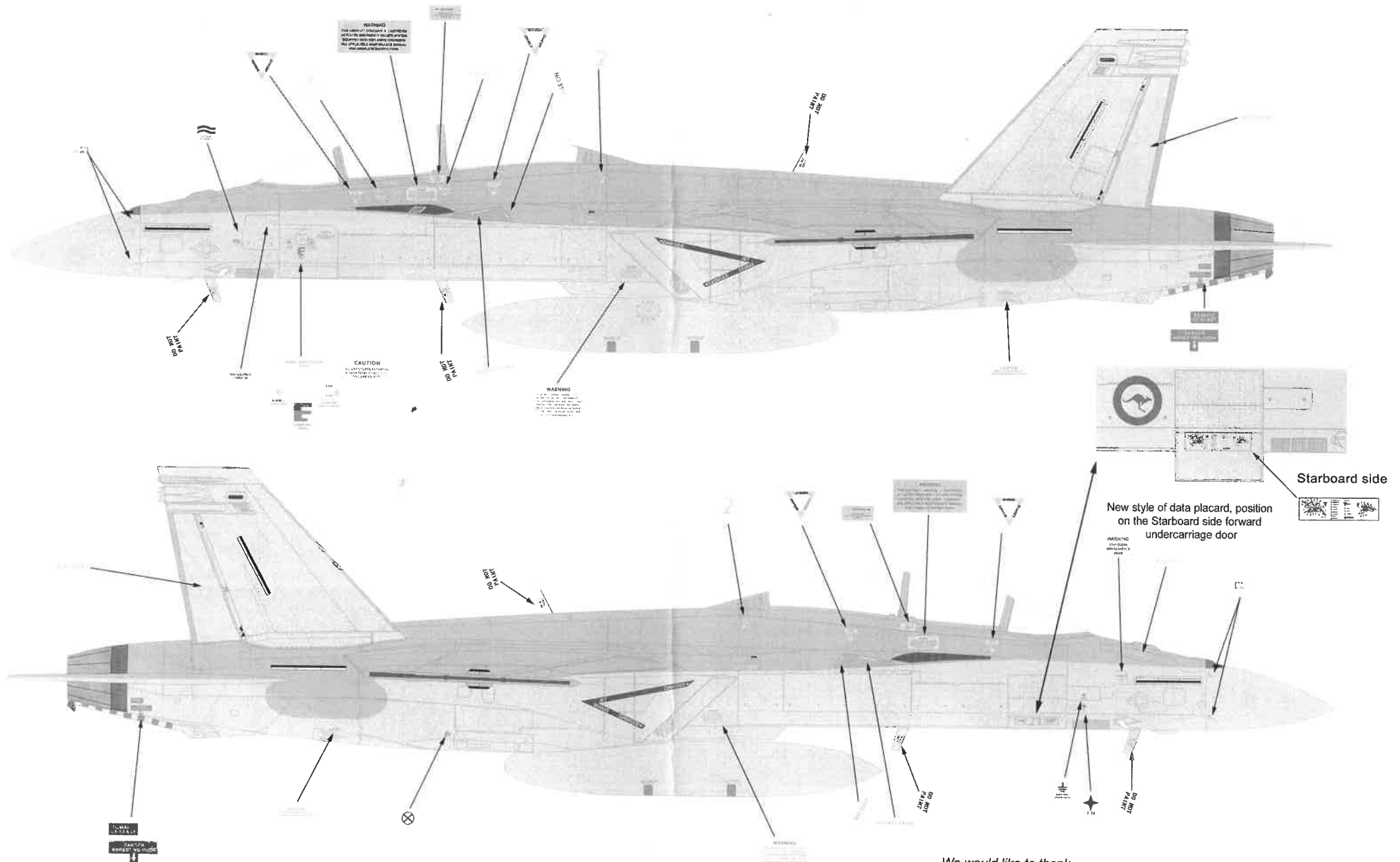

RDS-158 RAAF 1 Squadron 100th Anniversary 1916-2016

We would like to thank
CVW-5 USN Atsugi, Japan
and 1 & 6 Sqn RAAF Amberly
For their help in the production of this data set.

PRINTED AND DESIGNED BY:
ROMAN GRAPHICS AUSTRALIA
AUSTRALIAN MADE AND OWNED

This set is designed for the RAAF Super Hornets only.

Note: Lighter text (Data) goes on the upper surface (Darker surface) and the darker text (Data) goes on the lower (Lighter surface)

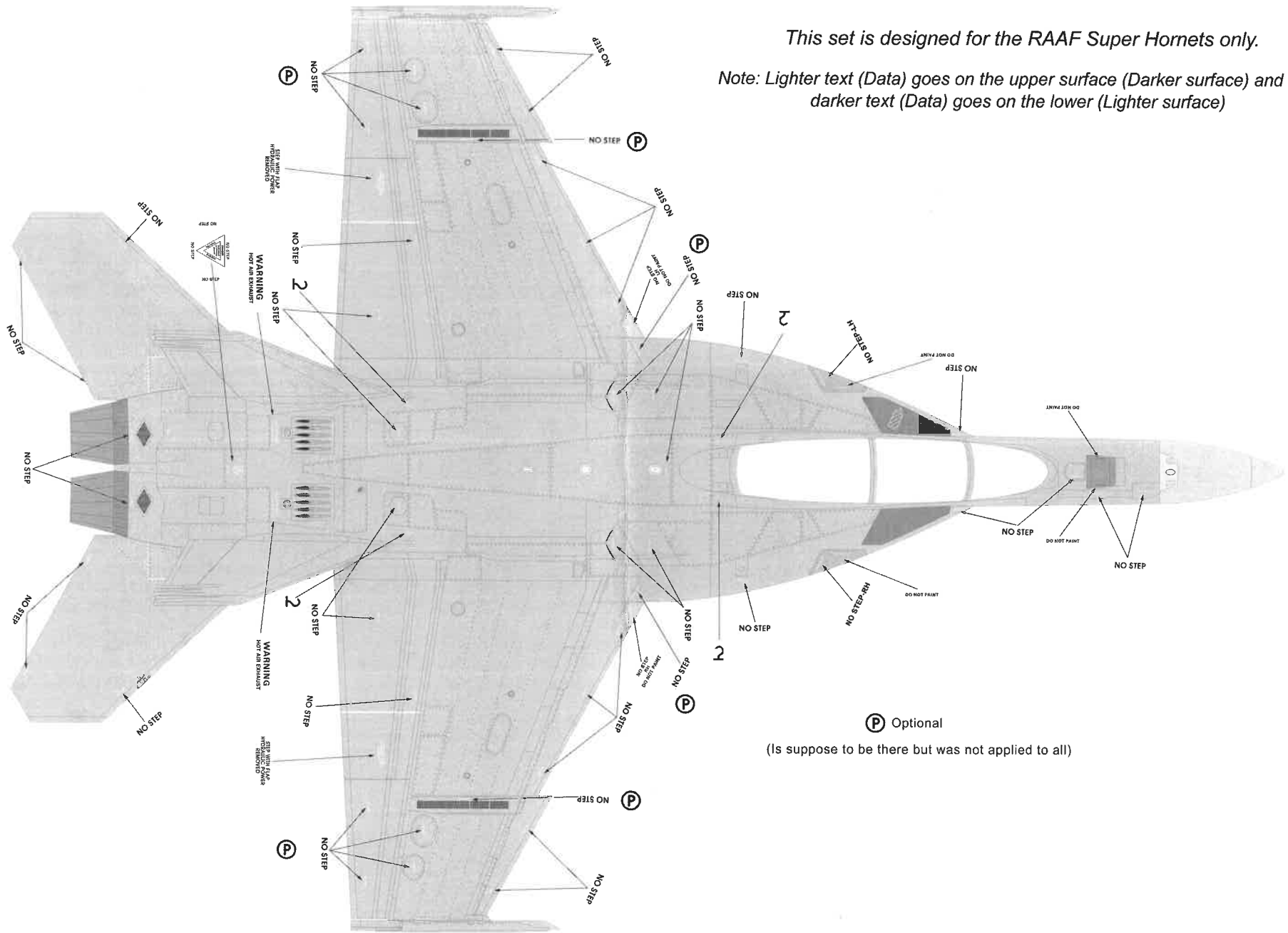

(P) Optional

(Is suppose to be there but was not applied to all)

This set is designed for the RAAF Super Hornets only.

Note: Lighter text (Data) goes on the upper surface (Darker surface) and the darker text (Data) goes on the lower (Lighter surface)

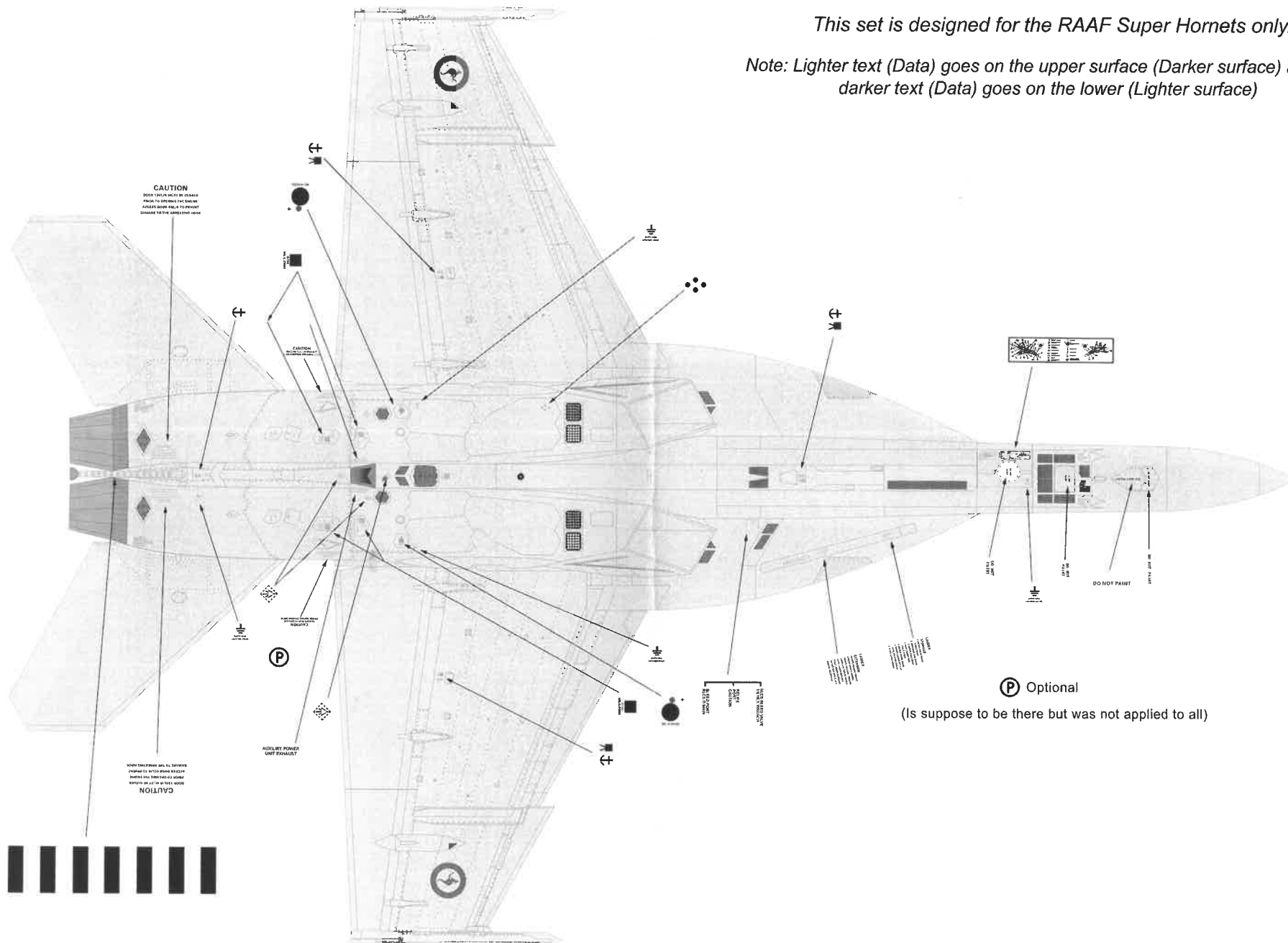

(P) Optional

(Is suppose to be there but was not applied to all)

Royal Australian Air Force
1 Squadron 100th Anniversary
1916 - 2016

Photos By: Steve Evans
ROMYTH GRAPHICS AUSTRALIA
AUSTRALIAN MADE AND OWNED

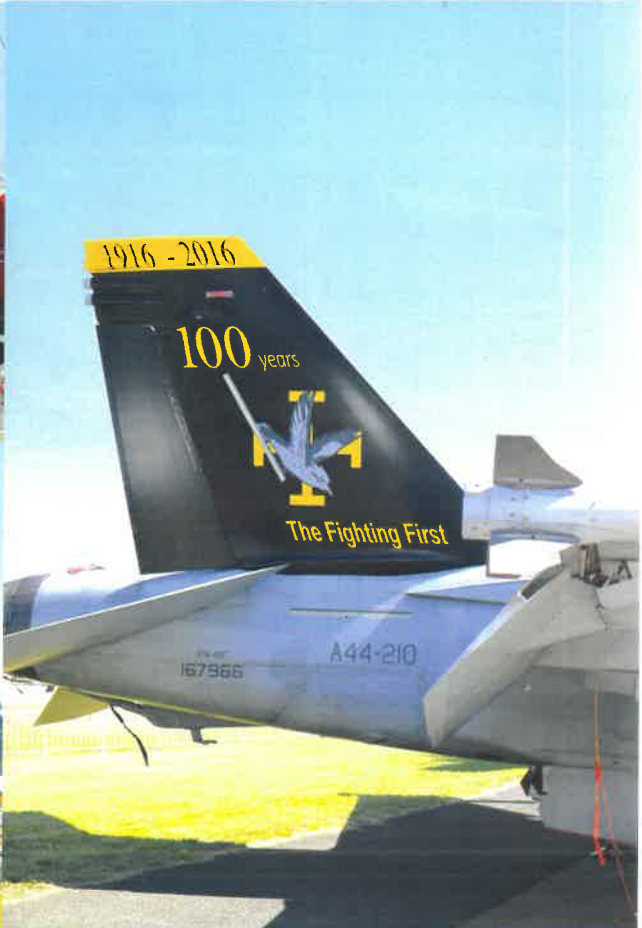

RAAF Super Hornet and Growler Exhaust detail

EA-18G EXHAUST



Note
different exhaust feathers
between the F and the G



These white decals are for the
inside Exhaust Feathers

EARLY
VERSION
RAAF F/A-18Fs



Today they fully coat the inner
feathers with a ceramic coating



The C square goes on both sides of the
middle wing pylons



Special thanks to USN's CVW-5
and the RAAF 1 Sqn for allowing us
close up access to there jets.



PRINTED AND DESIGNED BY:
ROYAL GRAPHICS AUSTRALIA
AUSTRALIAN MADE AND OWNED

Note: Lighter text (Data) goes on the upper surface (Darker surface) and the
darker text (Data) goes on the lower (Lighter surface)

RDS-158 RAAF F/A-18E/F/G Super Hornet LIV Data Set



Forward undercarriage doors

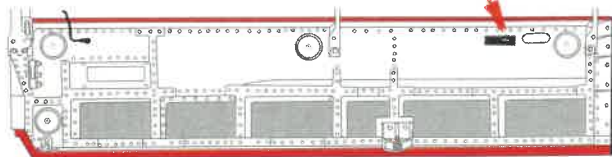
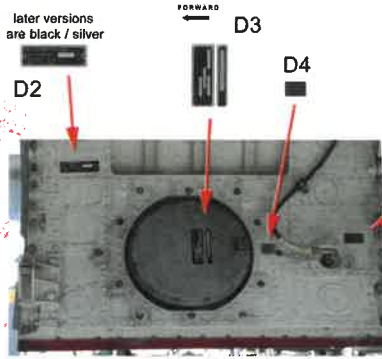

Forward undercarriage

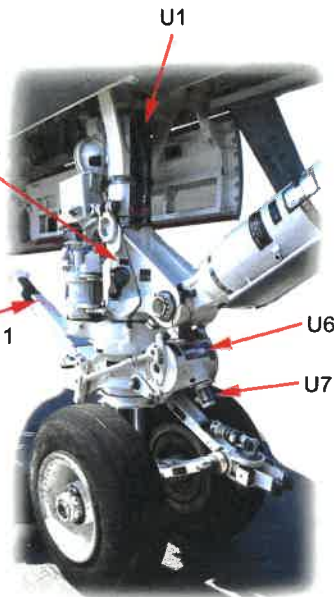
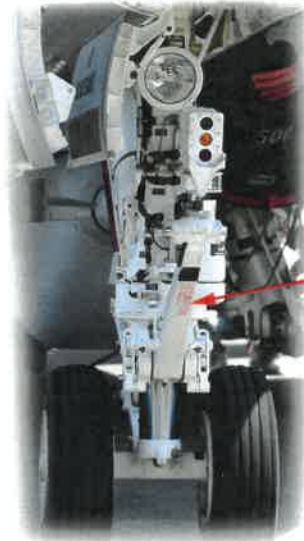
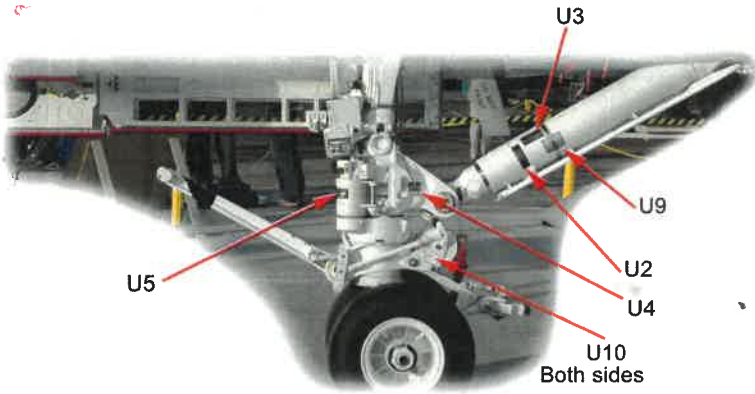

Rear undercarriage doors

Starboard side

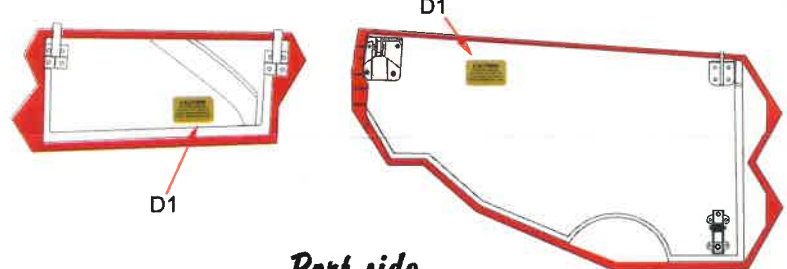

Port side

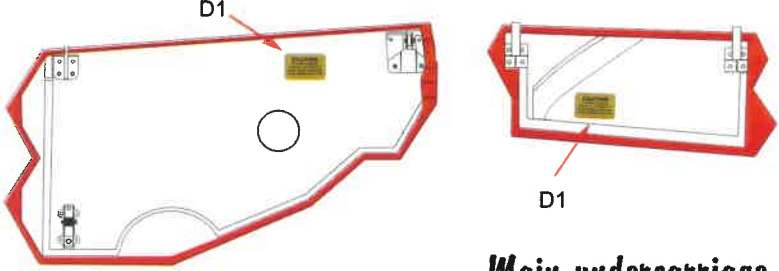

Special thanks to USN's CVW-5 and the RAAF 1 Sqn for allowing us close access to there jets.



Main undercarriage

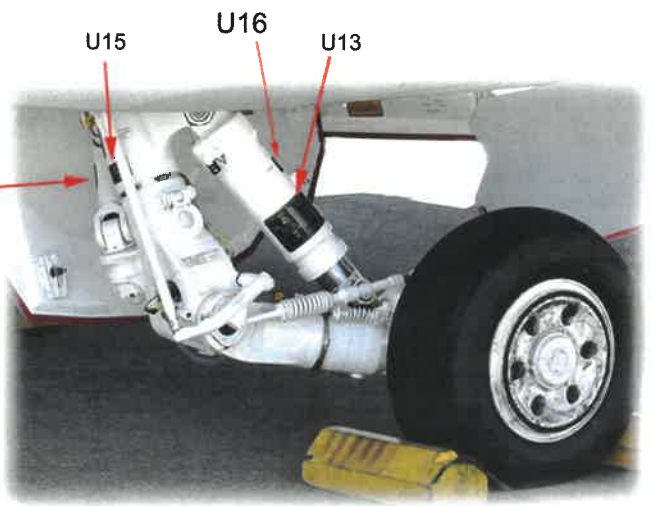
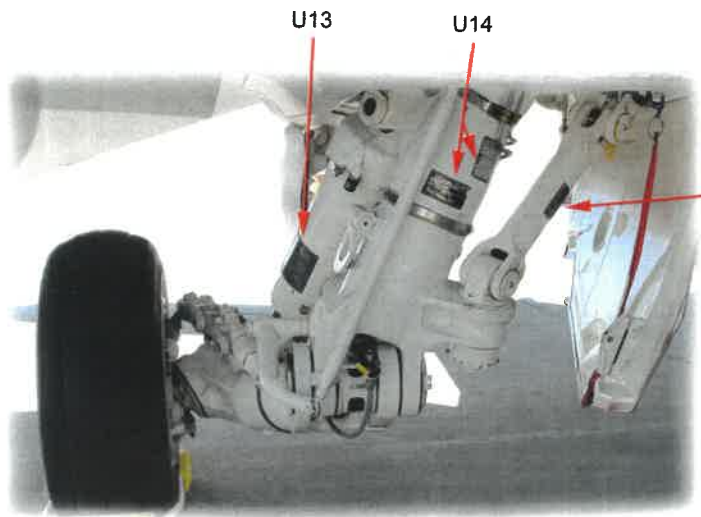

Starboard side rear undercarriage leg

Port side undercarriage leg

Ejection Seat

SJU-17 (V) 1/A - 2/A

PRINTED AND DESIGNED BY:
ROYTH GRAPHICS AUSTRALIA
AUSTRALIAN MADE AND OWNED

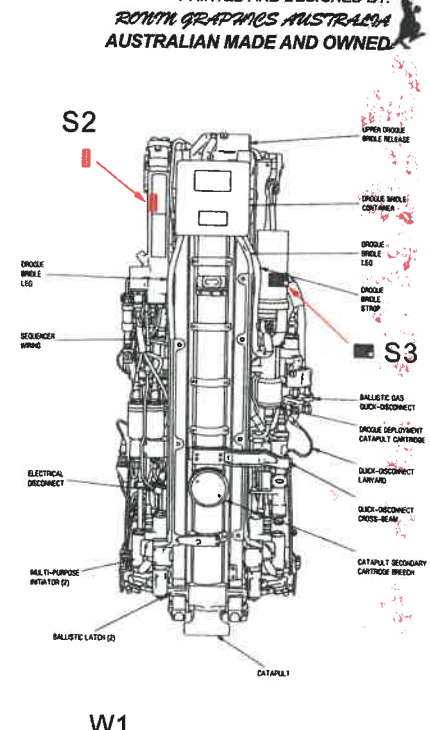
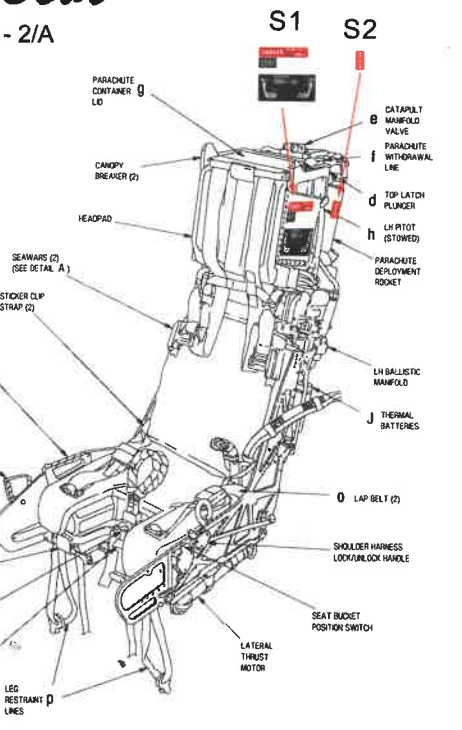
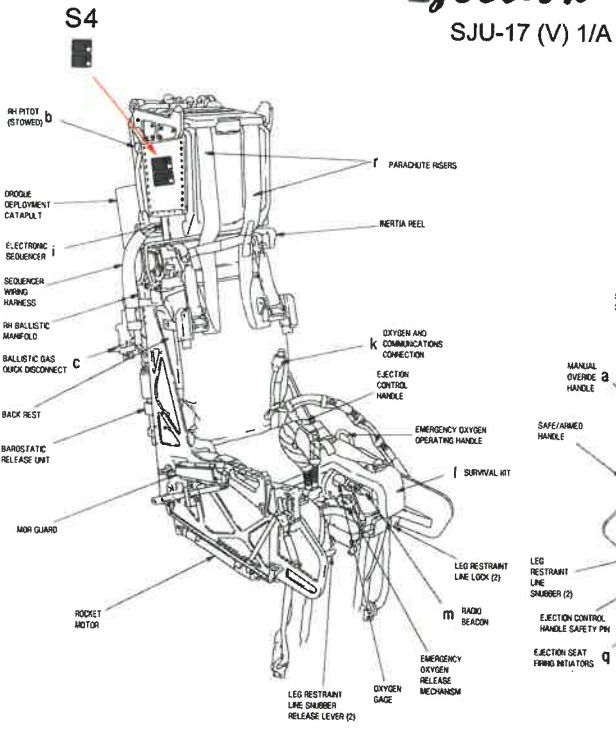

Aileron Skroud Plate

Apply to both sides of aircraft



ATFLIR POD



ID Plate behind rear seat

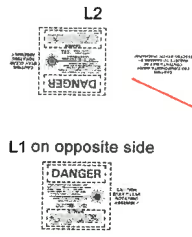

External Fuel Tanks

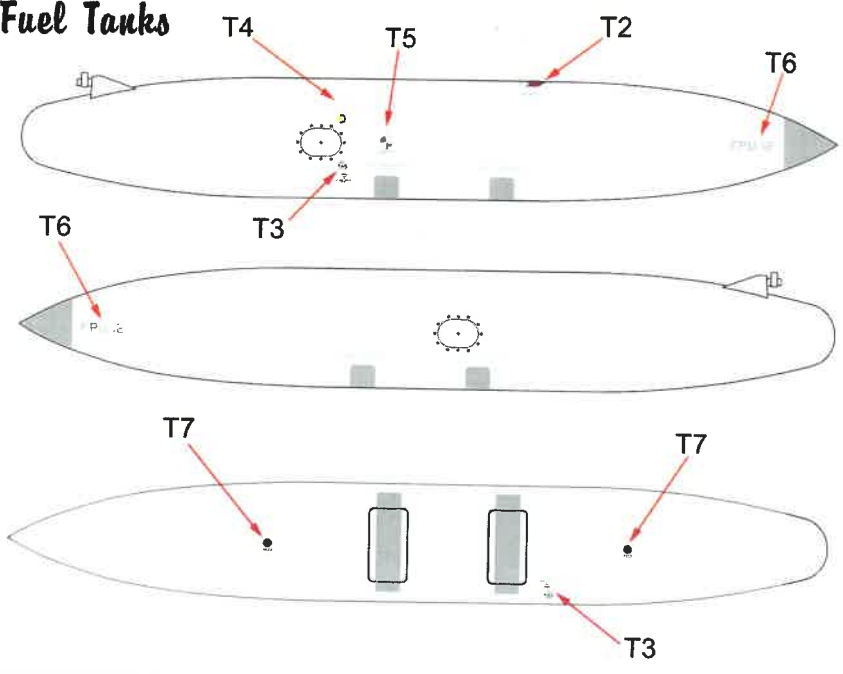

This decal goes on the bottom of all external fuel tanks.



1/48

1/48

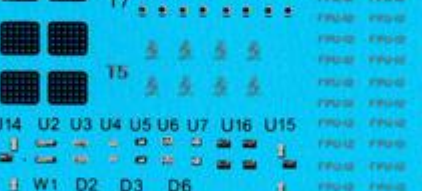
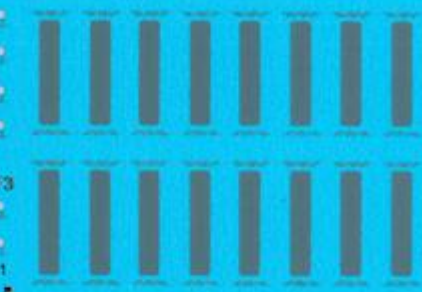
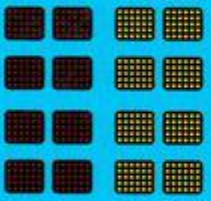

WEAPON PYLONS



WEAPON PYLONS

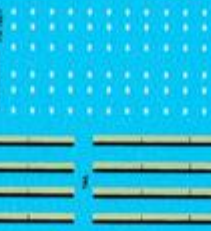

WEAPON PYLONS



WEAPON PYLONS 1/48

WEAPON PYLONS 1/48



210 210



© COPYRIGHT 2014
PRINTED BY
SOUTHERN PUBLISHING
MADE IN AUSTRALIA



1916 - 2016

1916 - 2016

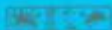

100 years

100 years

RA-487
167966

RA-487
167966

The Fighting First

The Fighting First



A44-210

A44-210

+ Op Okra

RDS-158 RAAF 1 Squadron 100th Anniversary 1916-2016