

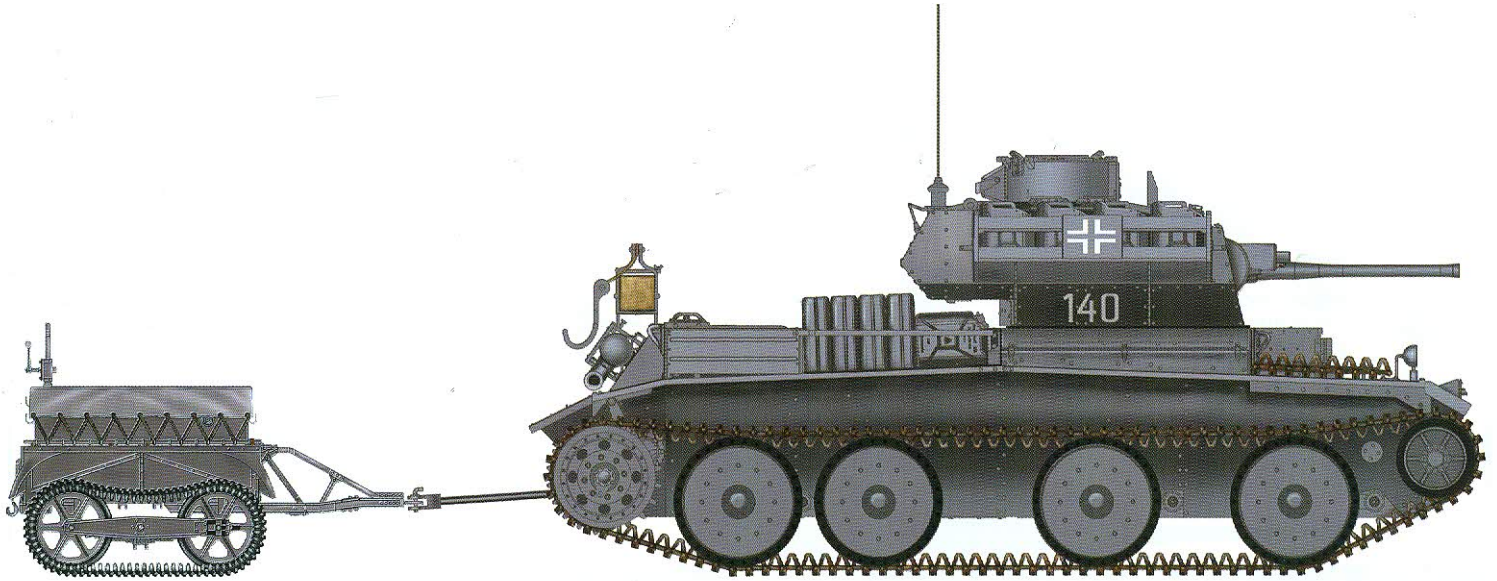

# Panzerkampfwagen Mk IV , 744( E ) ( A13 ) & UE Fuel Tank Trailer

## 1/35 SCALE

Bronco Models 德军 Mk.IV ,744(E) (A13)坦克与UE供油拖挂车



The A13, Cruiser Tank Mk.IV was the first of a long line of British Cruiser Tanks to use the American Christie suspension, which allowed high cross country speeds. Some of the first A13 tanks were sent to France with the British Expeditionary Force (BEF) in 1940 to defend against the German attack. Unfortunately the tanks were over run before they got a chance to fight. Though most tanks were destroyed by their crews, a few A13's were captured by the Germans and pressed into service as the Panzerkampfwagen 744(e). The Germans used some of these tanks in Russia, where they were fitted with PzKpfw IID tracks and other equipment. Little information is available on their use, but photographs confirm their use by the Pz.Abt.100 of 18th Panzer Division during the Barbarossa drive for Moscow. 🇬🇧

Information & research by Phil Greenwood

Der A13 (Typ Kreuzerpanzer Mk IV) war der erste einer langen Reihe von englischen Panzern mit dem amerikanischen Christie Fahrwerk. Die ersten Einsätze erfolgten im Rahmen des britischen Expeditionskorps 1940 in Frankreich gegen die Wehrmacht. Ohne nennenswerten Kampferfolg wurden viele A13 von ihren Besatzungen zerstört. Die erbeuteten einsatzfähigen Fahrzeuge gliederte man unter der Bezeichnung „Panzerkampfwagen 744 (e)“ ein. Nach der Umrüstung auf deutsche Ketten sowie weiteren Modifikationen wurden die A13 nach Russland verlegt. Über den Verbleib ist wenig bekannt, aber zeitgenössische Fotografien belegen den Einsatz bei der 18. Panzerdivision vor Moskau. 🇩🇪

© Translation Michael Knoblich Academy Europe

A13 Mk.IV 型是延用有超卓越的越野速度及性能，安装了美国‘克里斯蒂’坦克避震悬挂系统的英国巡航坦克。1940 年首批被生产出来的 A13 坦克被派送到法国前线的英国远征军 (BEF) 协助德军的攻击。不幸局势急转直下，致使大部份这些坦克被自己的乘员所毁坏，部份的 A13 落入德国人手里并重新使用，按照传统德国人将其命名为 Panzerkampfwagen 744 (e)。德国人在俄国使用了其中部份 A13 坦克，并将其某些部件如履带及车上装备修改为德式，可与 Pz IID 型坦克共享。虽然很少资料提到他们的存在，但有历史照片证实：德国人将这些 A13 坦克装备其第 18 装甲师之第 100 装甲团第 1 营，用于进攻莫斯科的‘巴巴罗沙’行动上。 中文

# ILLUSTRATION 图示说明：

## CORRECT METHOD FOR APPLYING DECALS : HINWEISE ZUM ANBRINGEN DER DECALS : 正确贴水贴纸的方法：

1. Clean model parts surface with wet cloth. Entsprechende Stellen am Modell feucht reinigen.  
将需要贴水贴纸之部位表面擦干净。
2. Cut out the decal parts and dip them in cold water for 15 ~20 seconds. Decal ausschneiden und für 15-20 Sek. ins Wasser legen.  
将所需之贴纸剪下泡在清水里约15至20秒。
3. Place it on correct position of the model kit. Decal an der richtigen Stelle auflegen.  
将湿透之贴纸取出置放于正确之位置旁。
4. Slide off the decal from the base paper on to the model kit surface with a cotton stick. Decal mit Wattestäbchen festhalten und Papier darunter wegziehen.  
用棉花棒轻推贴纸表面使其从底纸滑出至模型表面之正确位置。
5. When decal get dry then complete. Decal mit Papiertuch andrücken und trocknen.  
待其自然干透后即完成。

## CON INSTRUCTION: 图标说明：



Open Hole  
Loch bohren  
钻孔



Remove  
Abtrennen  
切除



2 Sets needed  
Vorgang wiederholen  
同样的制作二组



Bend  
Biegen  
曲折



Optional  
Auswahl  
可以选择采用



Apply Decal  
Decal anbringen  
贴水贴纸



Instant Glue For Metal  
Sekundenkleber verwenden  
瞬间接着剂,金属用



Fill Hole  
Verspachteln  
把孔填平



Do not cement  
Nicht kleben  
不用粘合

## COLOR SUGGESTION: FARBTABELLE: 涂装指引：

Color 涂料表	MR. Hobby	Hobby Color	Humbrol	Tamiya
Steel Stahl 黑铁色	H-18	C-28	53	/
Wood brown Holzbraun 木棕色	H-37	C-43	/	/
Silver Silber 银色	H-8	C-8	11	X-11
Flat white Matt Weiß 消光白	H-11	C-62	34	XF-2
Tyre black Reifen Schwarz 轮胎黑	H-77	C-137	85	/
Semi-gloss black Schwarz Seidenmatt 半光黑	/	C-82	/	/
White Weiß 白色	H-1	C-1	/	X-2
Flat black Matt Schwarz 消光黑	H-12	C-33	33	XF-1
Burnt iron Metall brüniert 烧铁色	H-76	C-61	/	/
Rust Rust 铁锈色	H-334	/	113	/
German gray Deutsch grau 德国灰	H-32	C-40	92	XF-63

## READ BEFORE ASSEMBLING: VOR ZUSAMMENBAU LESEN: 组装必读：

- Carefully Study instruction before assembling. Anleitung studieren und verständlich machen. 组装前请阅读清楚制作指引。
- Keep plastic model glue and tools away from children. Kleber, Farben, Werkzeuge und Plastiktüten von Kindern fernhalten. 胶水,油漆及工具勿让小孩接触。
- Do not use cement or paint near open flame or sparks. Kleber/Farbe nicht in Nähe von offenen Flammen. 胶水及油漆勿接触火种。
- Do not work in closed room. Nur in ausreichend belüfteten Räumen arbeiten. 勿在密封地方制作模型。

Printed in China

PARTS LIST 零件指示表:

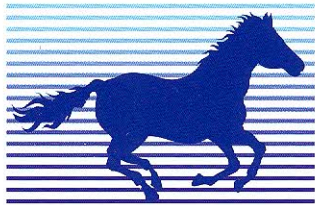

**BRONCO**

**Bronco Models**

Copyright © 2015

Made in China

中国制造

No use parts  
不要部件



Ⓐ × 1

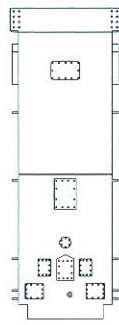

Ⓑ × 1

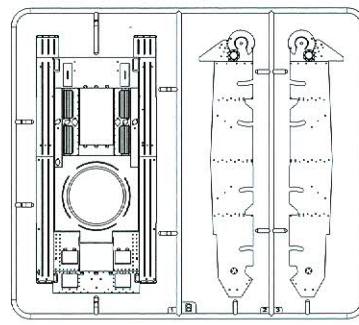

Ⓚ × 1

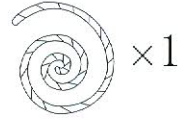
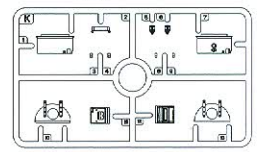

× 1

Ⓒ<sub>1</sub> × 1

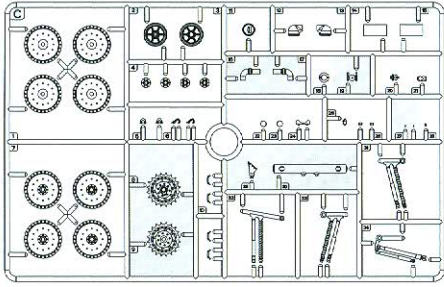

Ⓒ<sub>2</sub> × 1

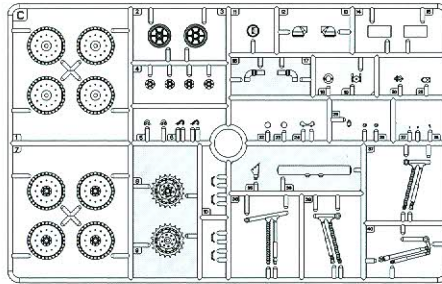

Ⓓ × 1

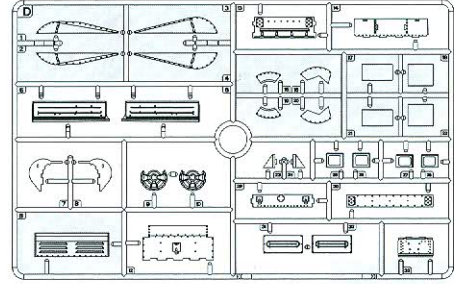

Ⓜ × 1

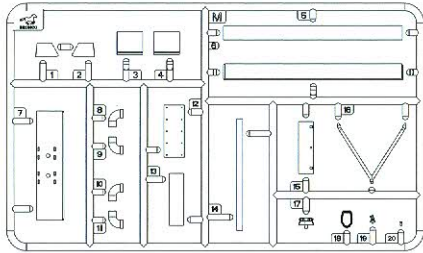

Ⓔ × 1

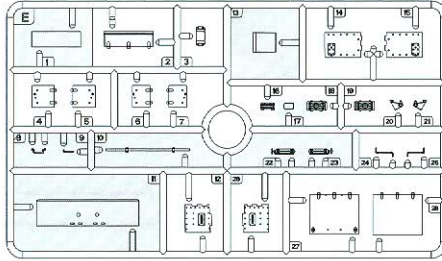

ⓓ × 1

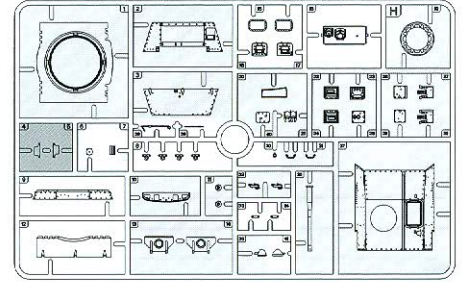

Ⓣ × 6

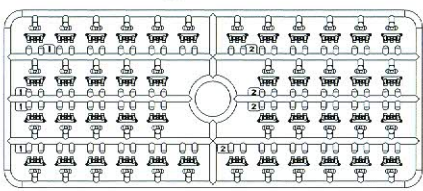

Ⓝ × 1

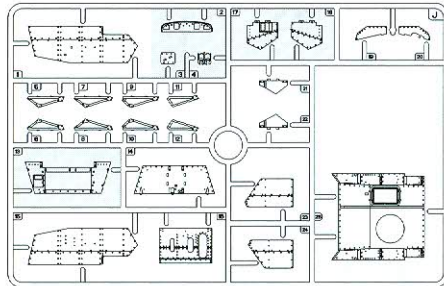

Ⓜ<sub>a1</sub> × 2

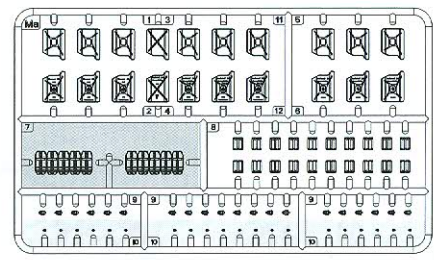

Ⓦ × 1

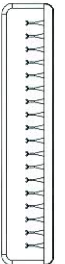

Ⓜ<sub>a</sub> × 2

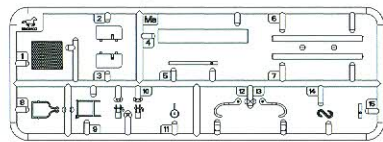

Ⓒ<sub>a</sub> × 1

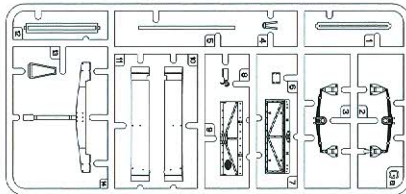

Ⓟ × 1

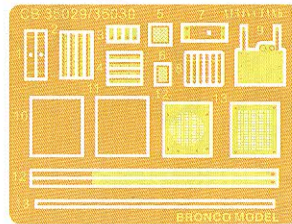

Ⓟ<sub>B</sub> × 2



Ⓝ<sub>a</sub> × 1

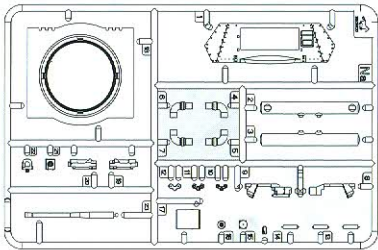

Ⓒ<sub>c</sub> × 1

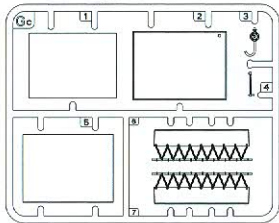

Ⓒ<sub>b</sub> × 2

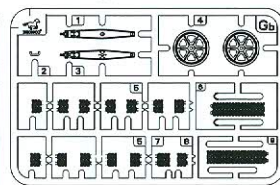

Ⓟ<sub>A</sub> × 1

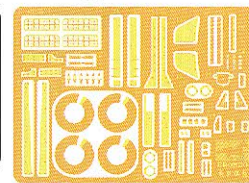

DECAL x1

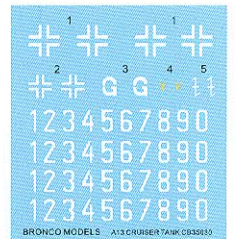

Ⓒ<sub>a</sub> × 1

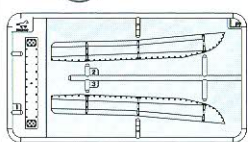

Ⓒ<sub>c</sub> × 1

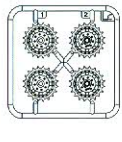

Ⓒ × 1



Ⓝ × 1

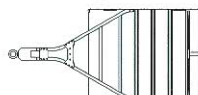

Ⓟ<sub>C</sub> × 1



CB35030SP

# ILLUSTRATION 图示说明：

- 1** Caution: This kit contents a lot of small accurate parts, please carefully to read before to assembly.  
此套件包含不少精细零件，请在制作前先翻阅说明书了解清楚。

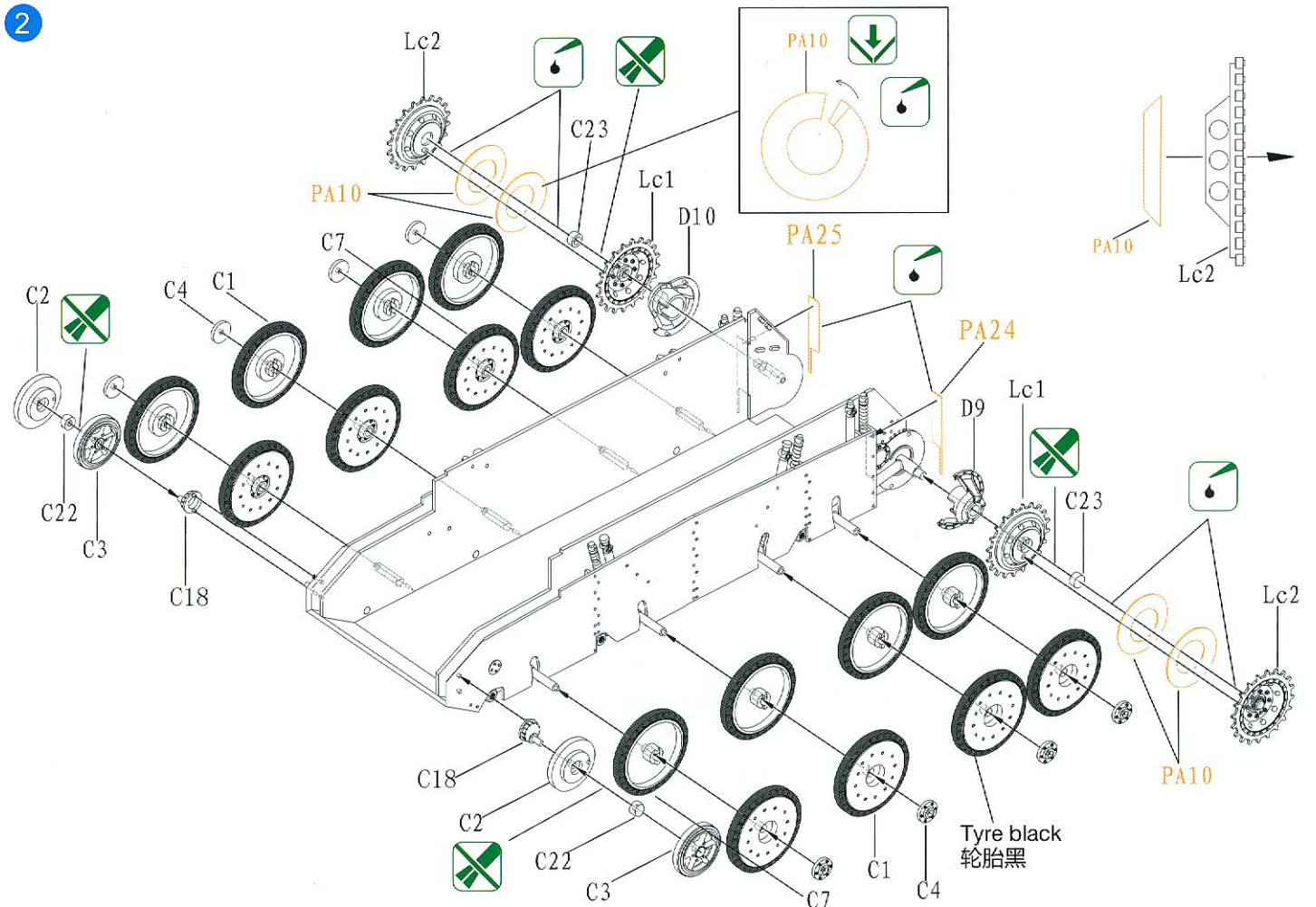
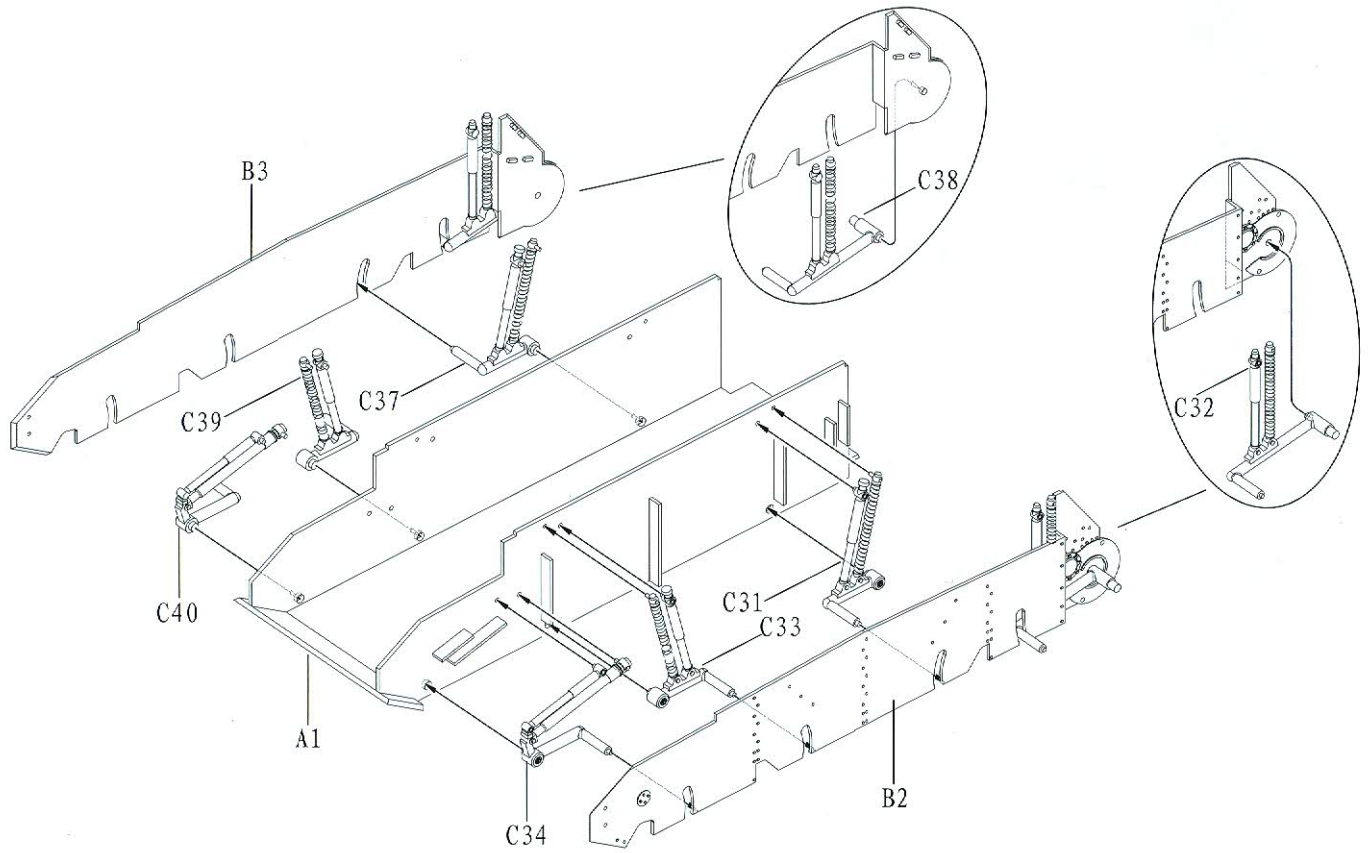
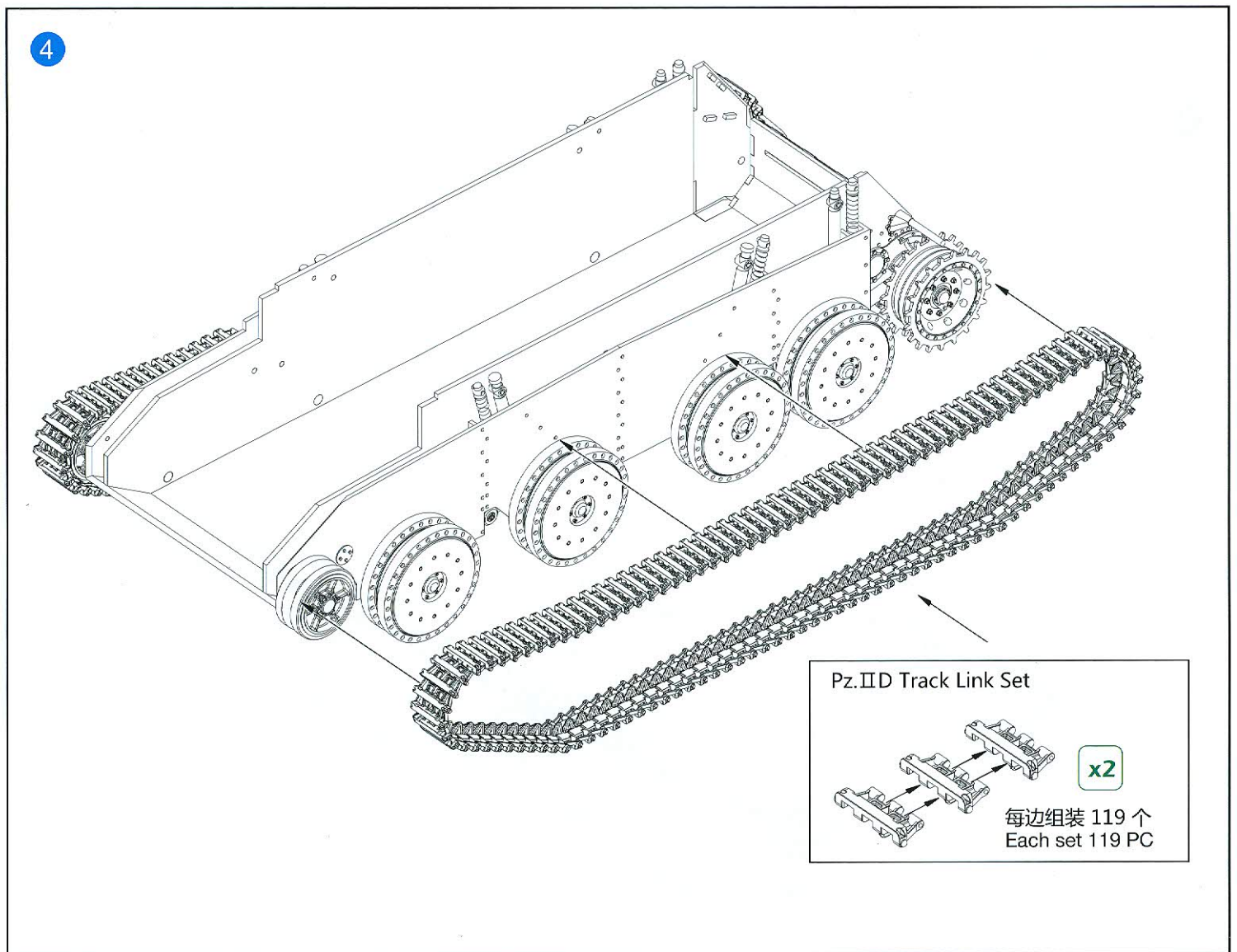
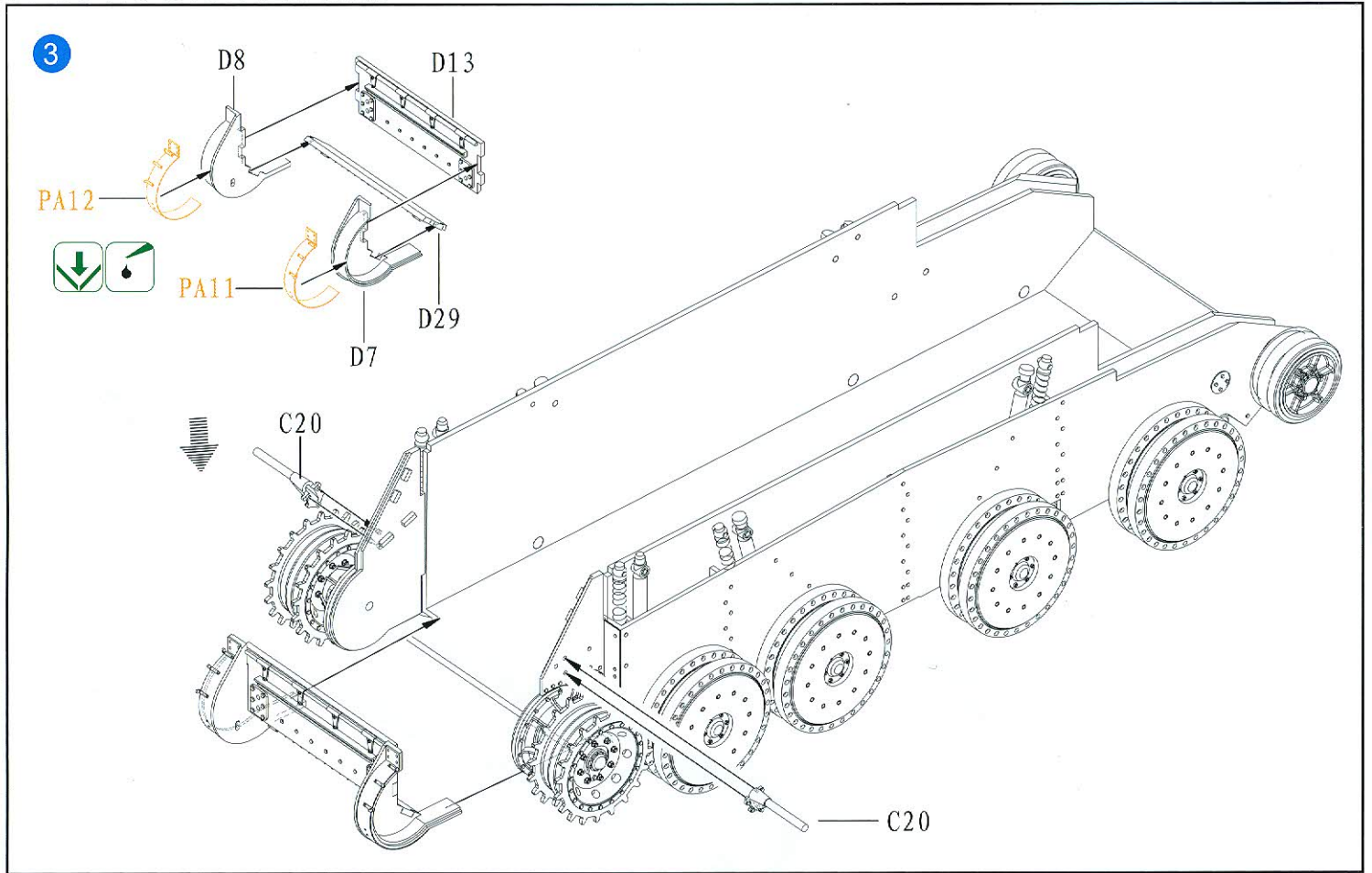

ILLUSTRATION 图示说明：



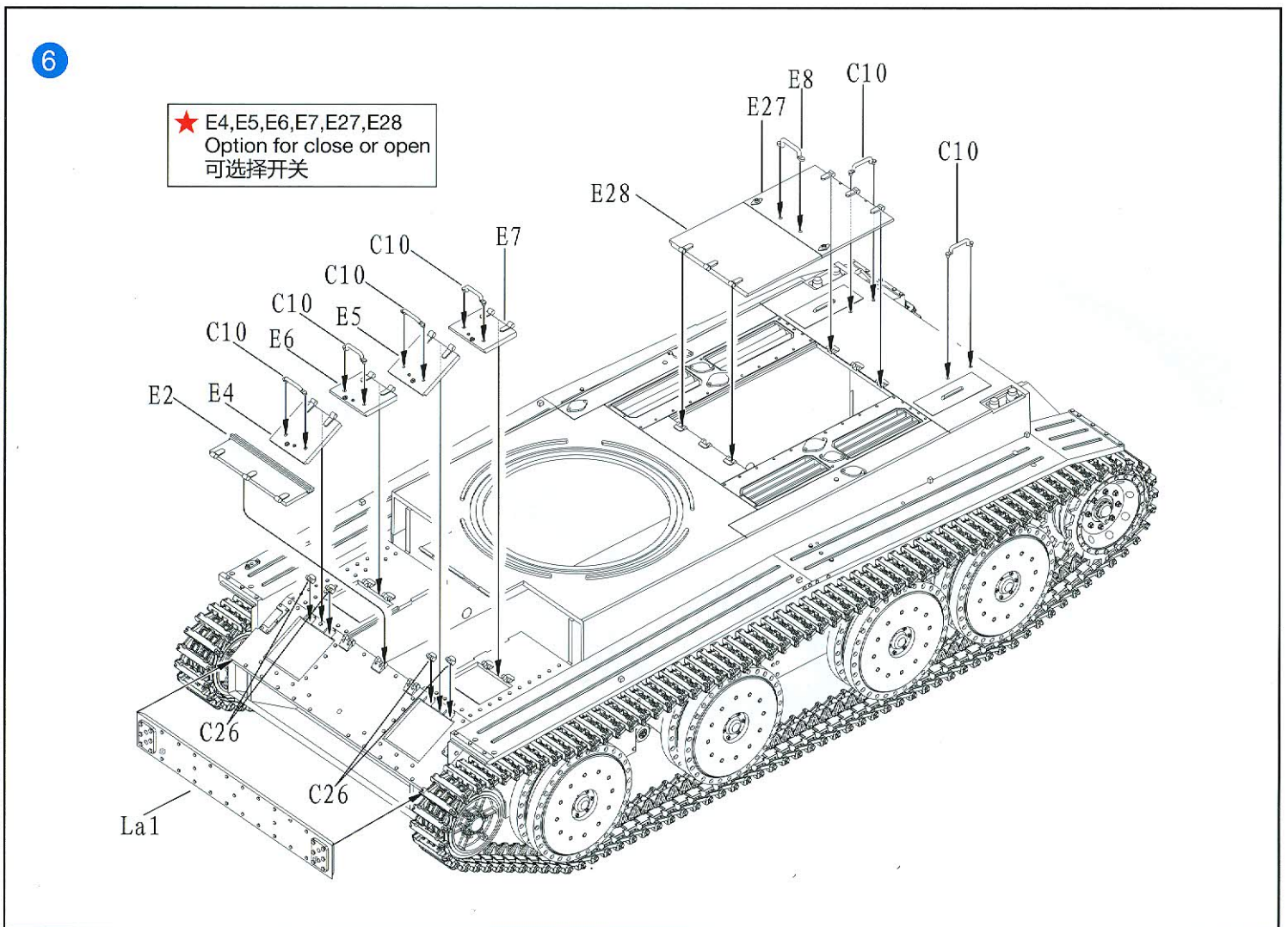
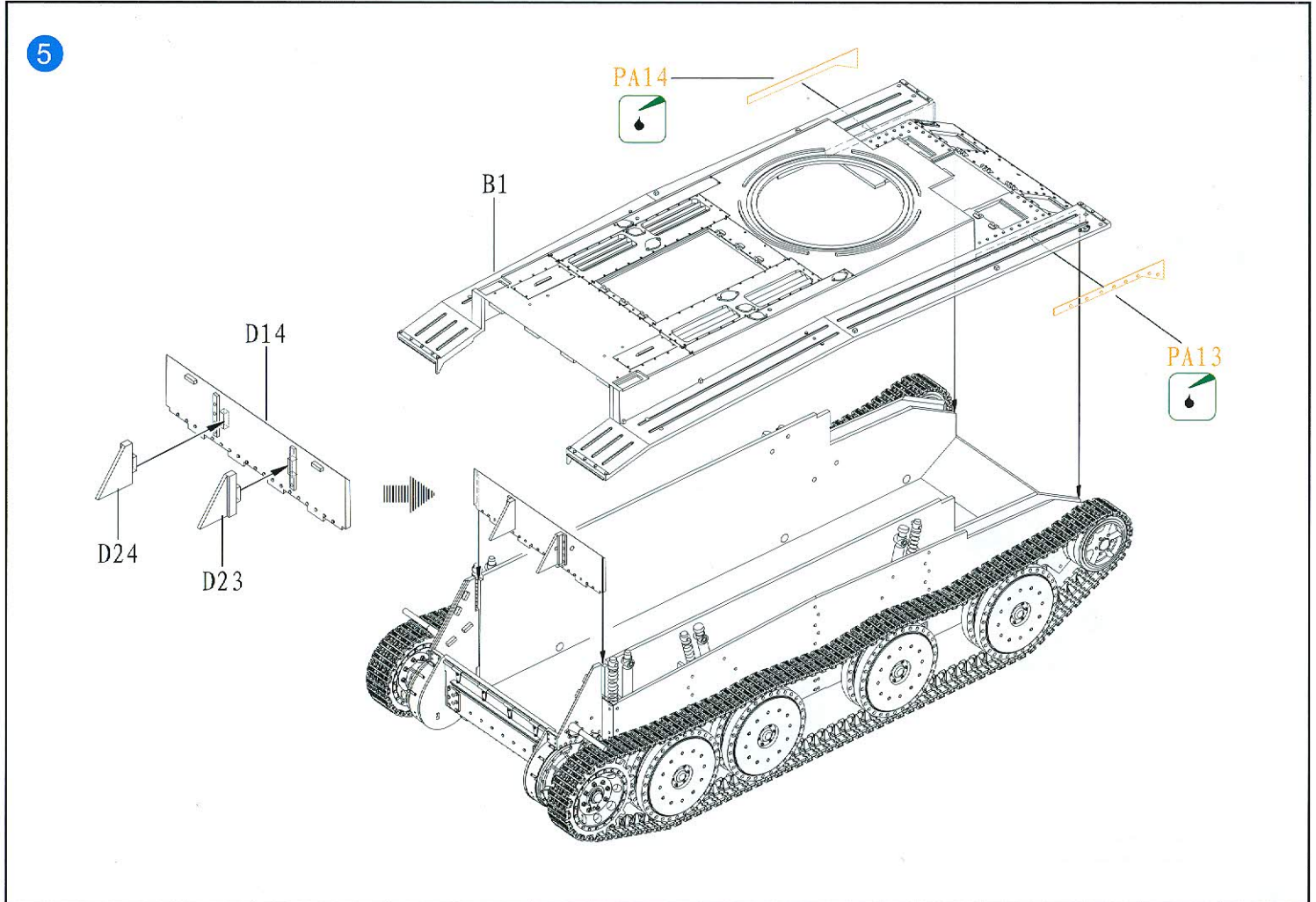

ILLUSTRATION 图示说明：

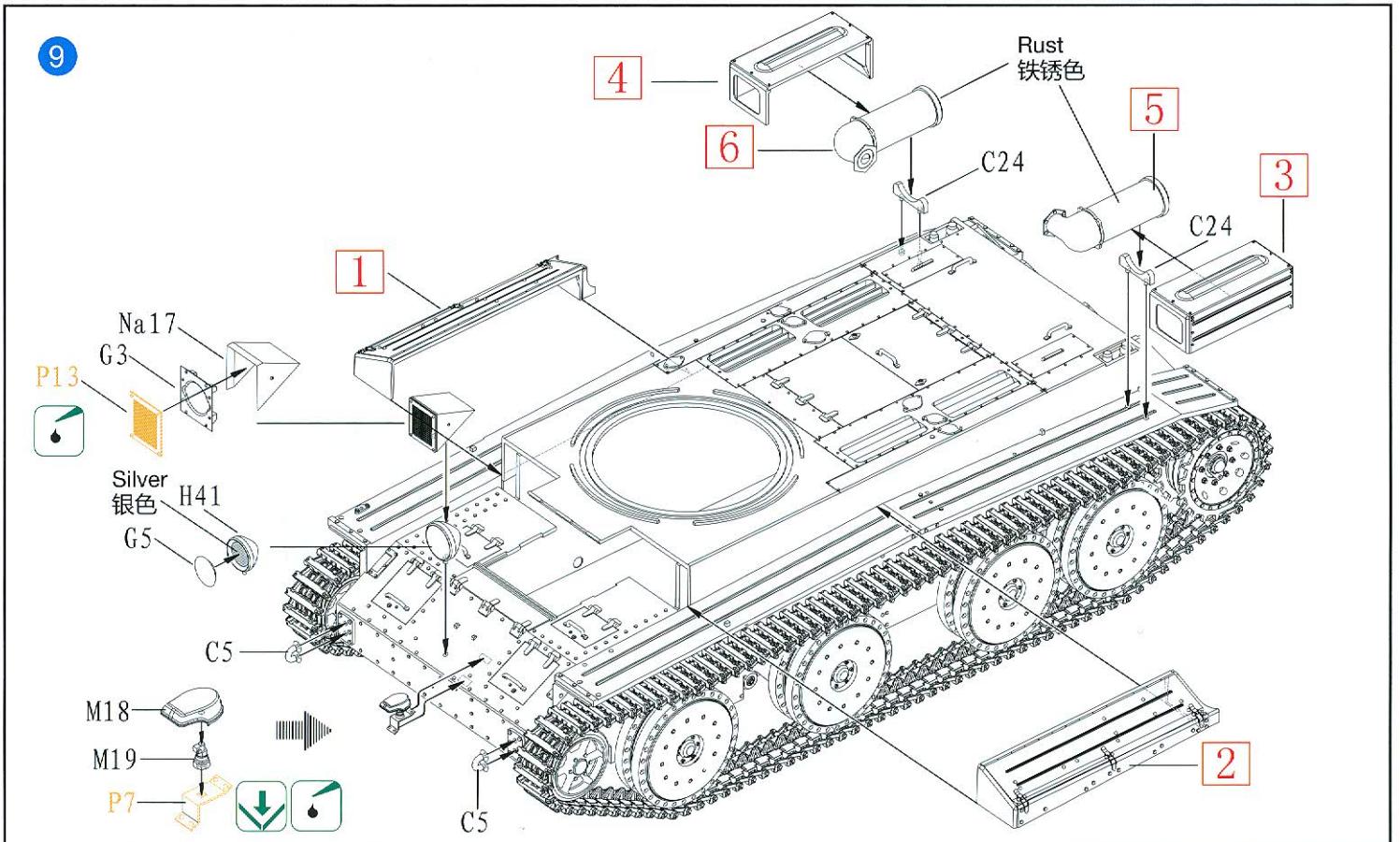
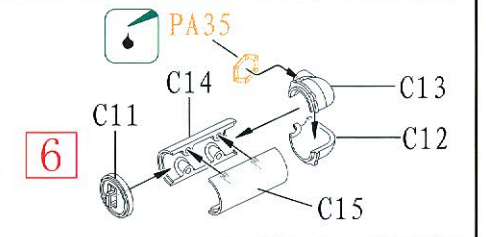
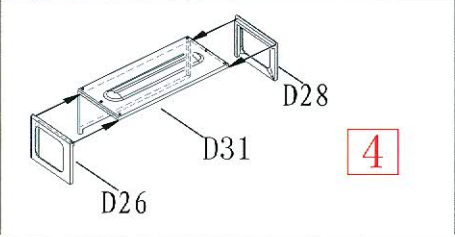
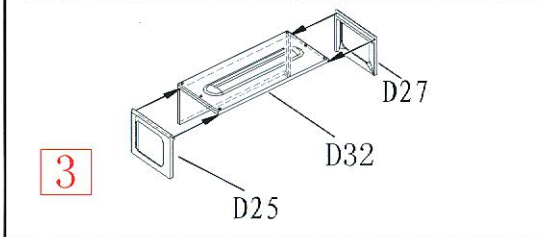
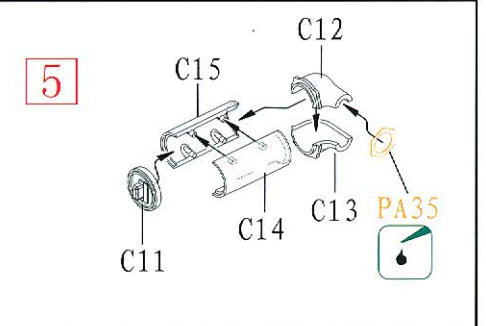
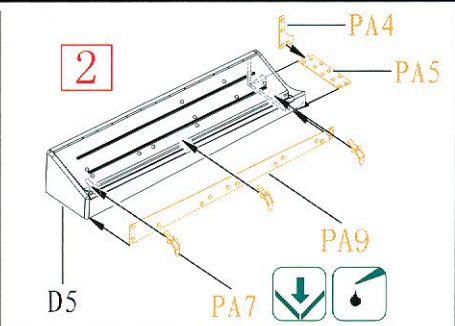
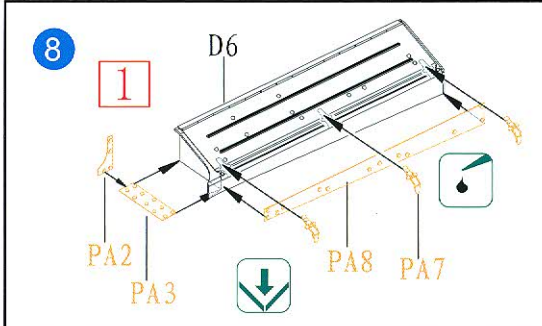
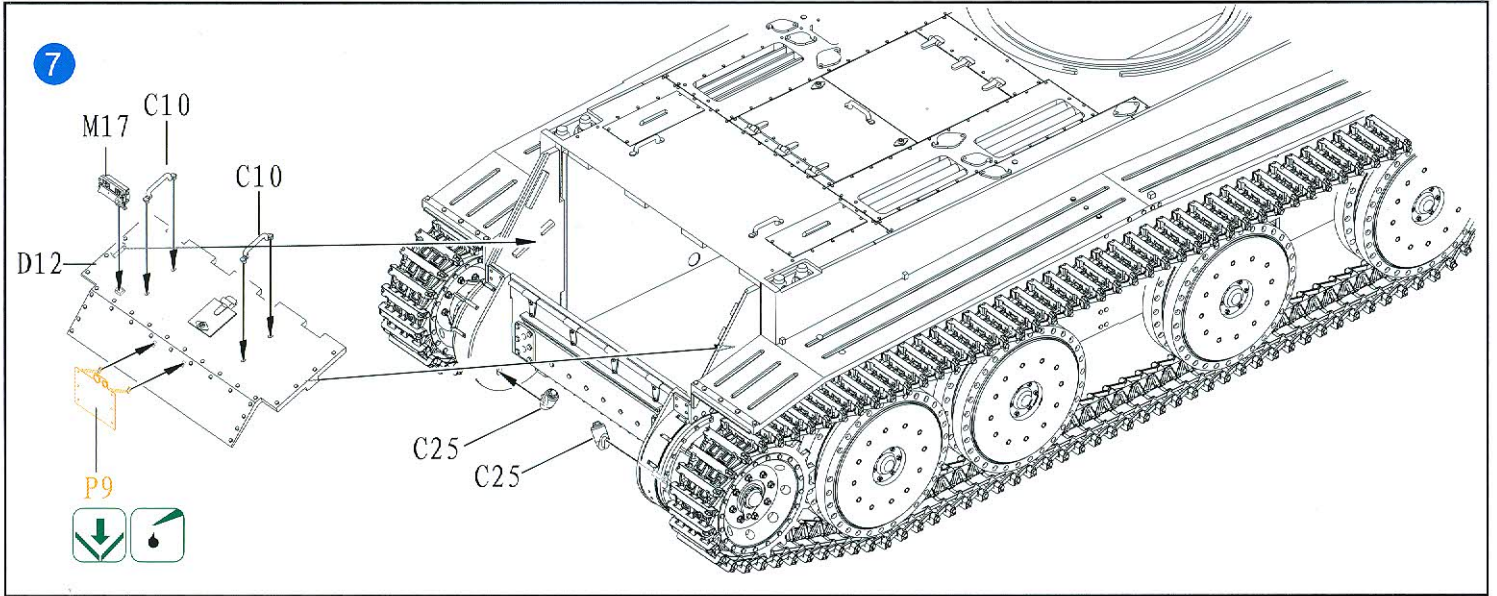
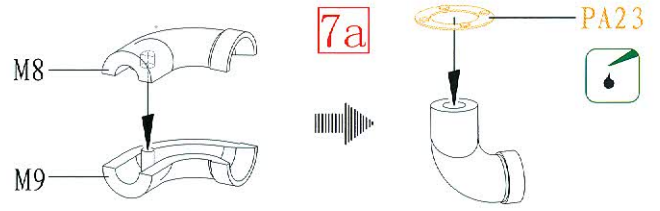
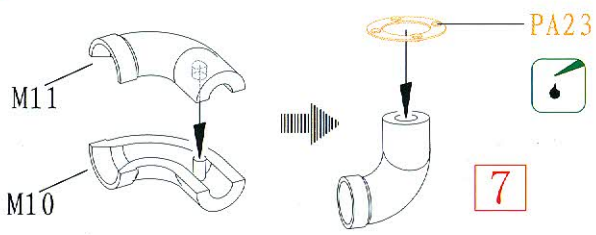
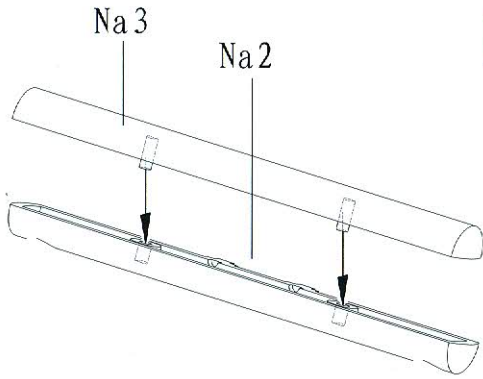

ILLUSTRATION 图示说明：

10



8



9

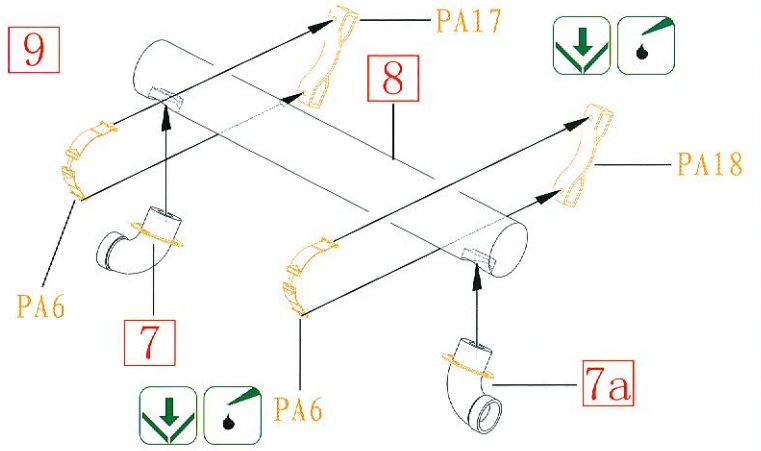

11

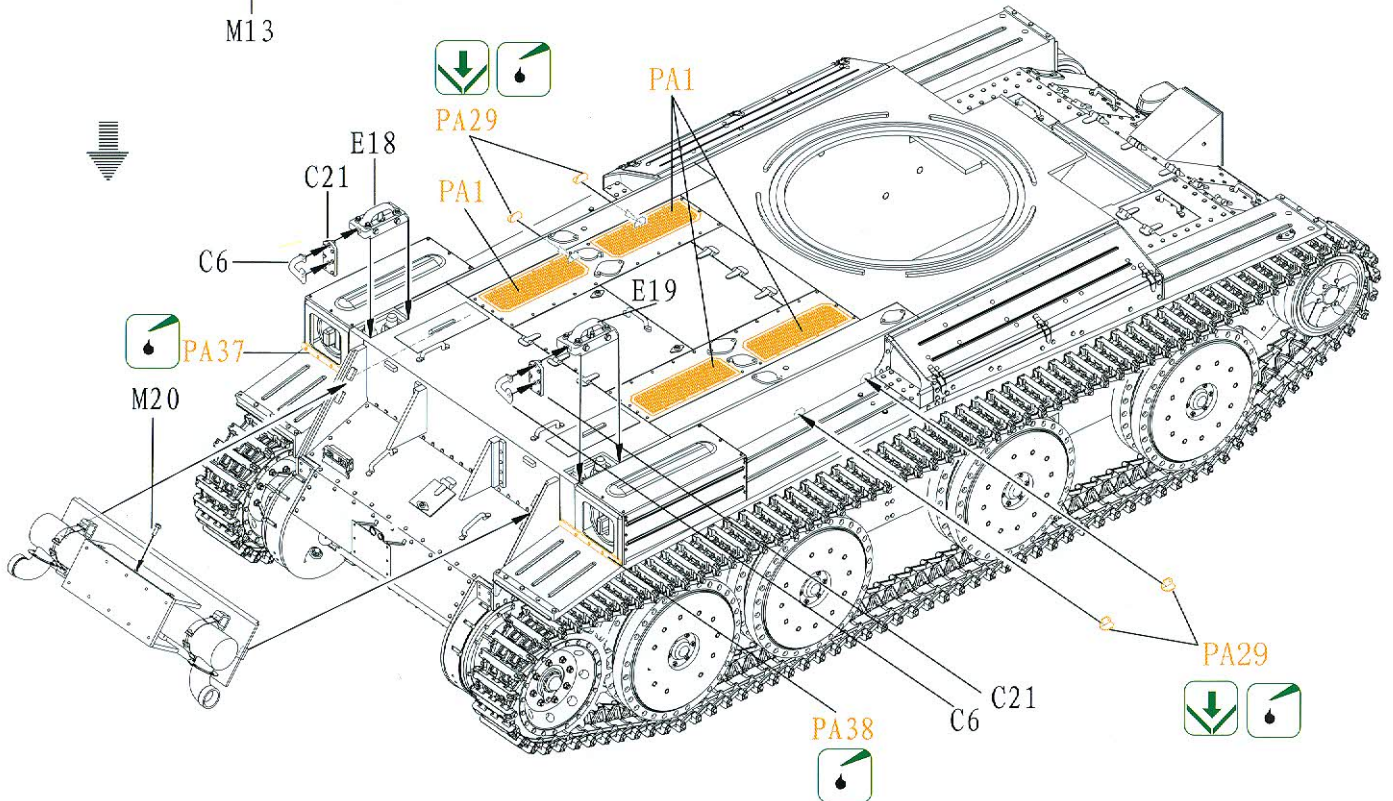
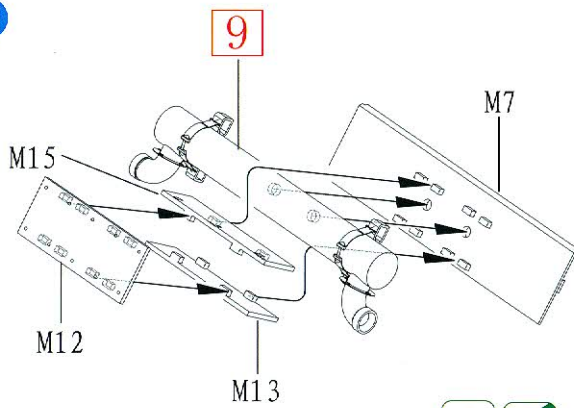
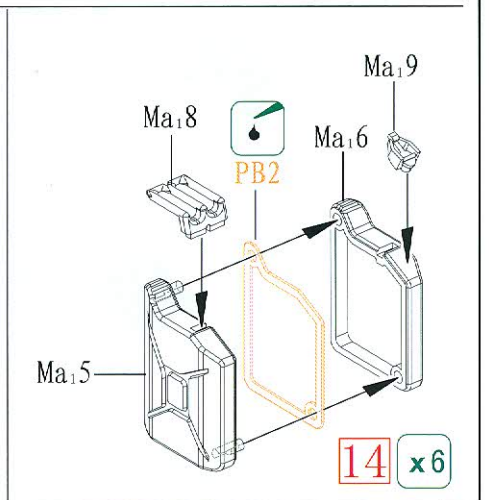
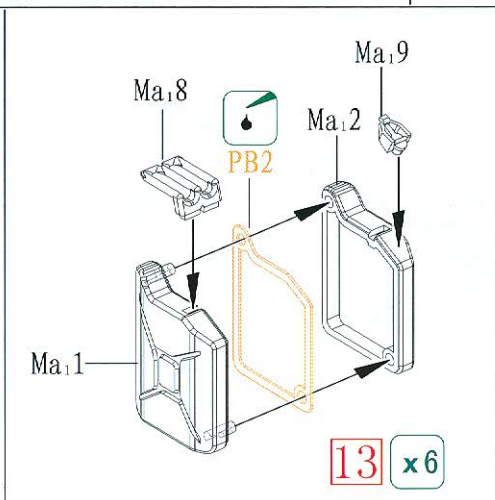
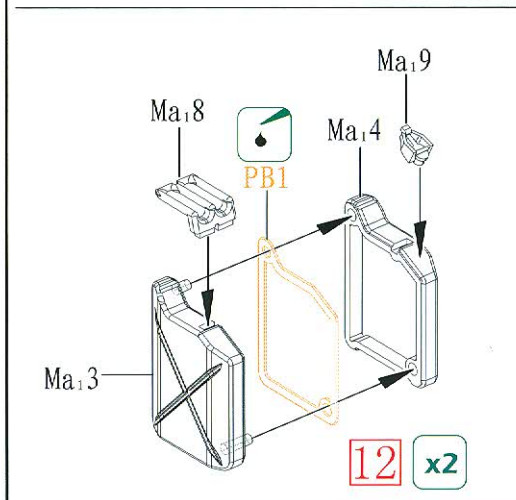
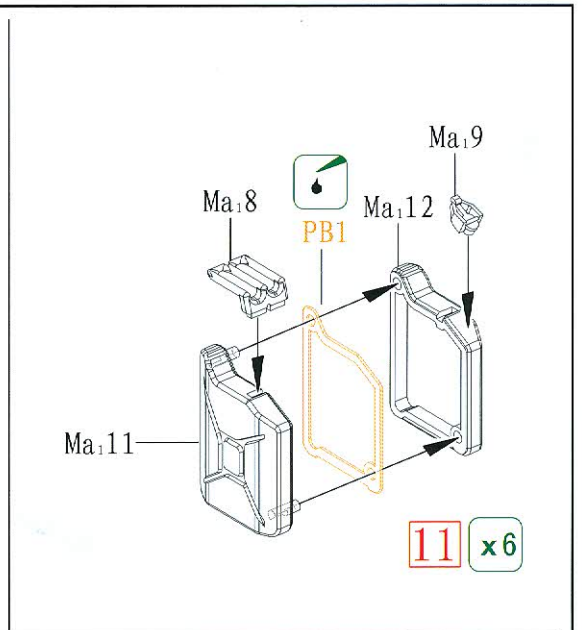
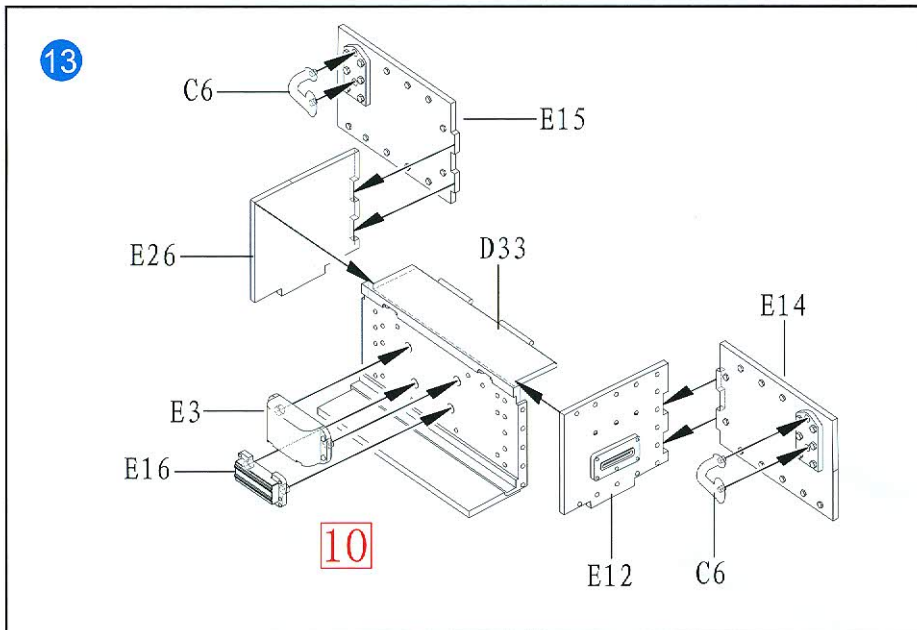
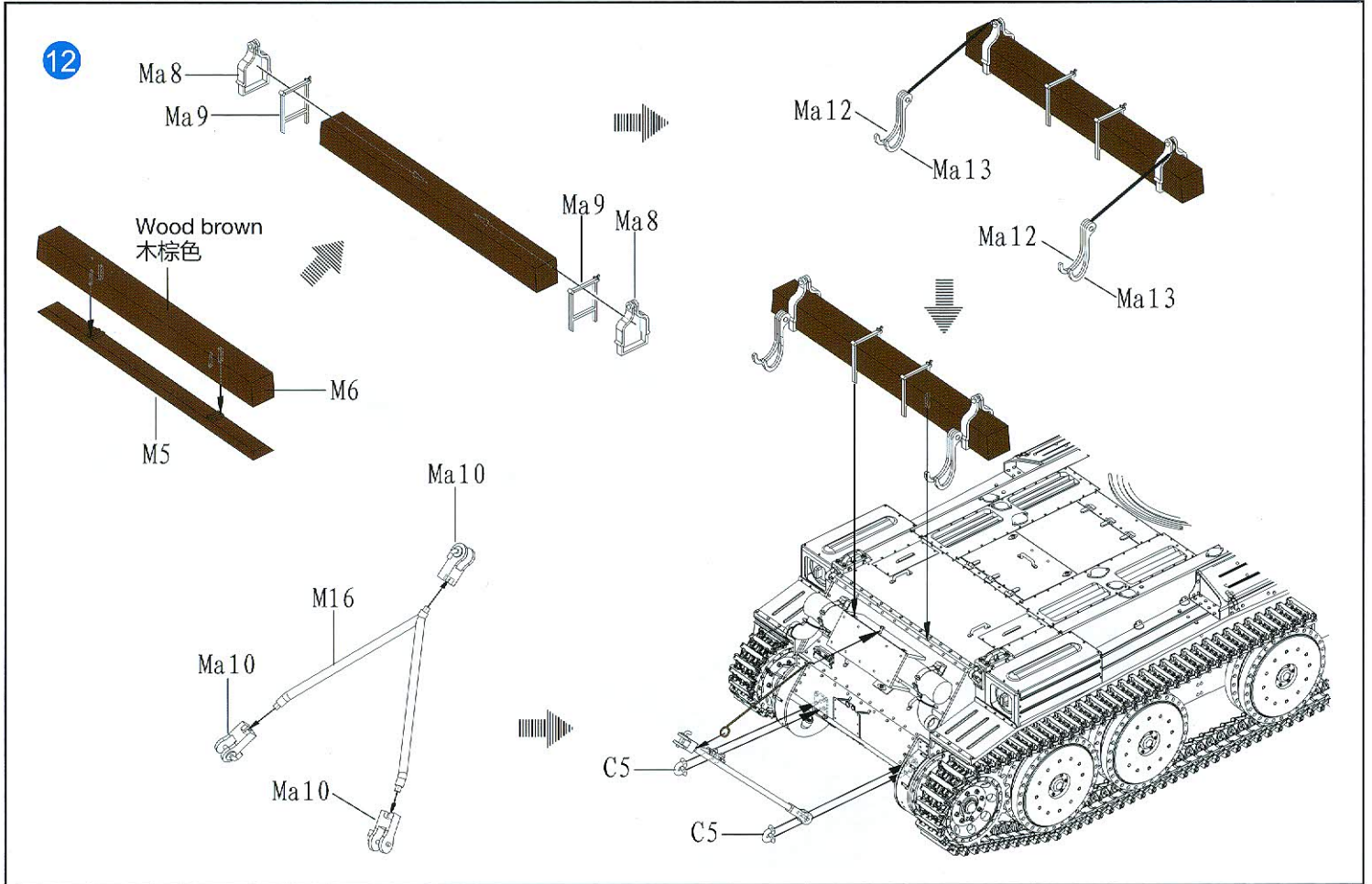
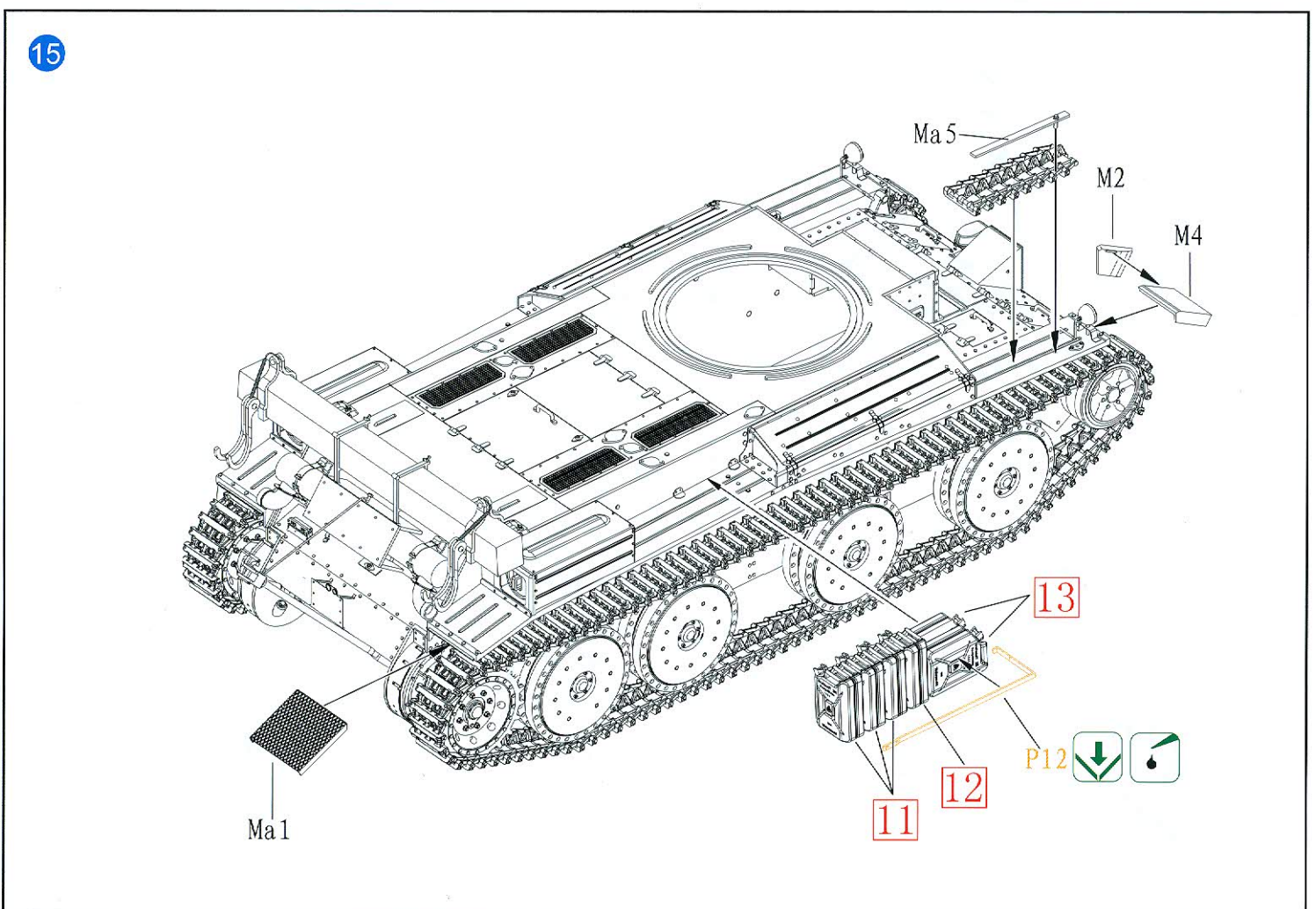
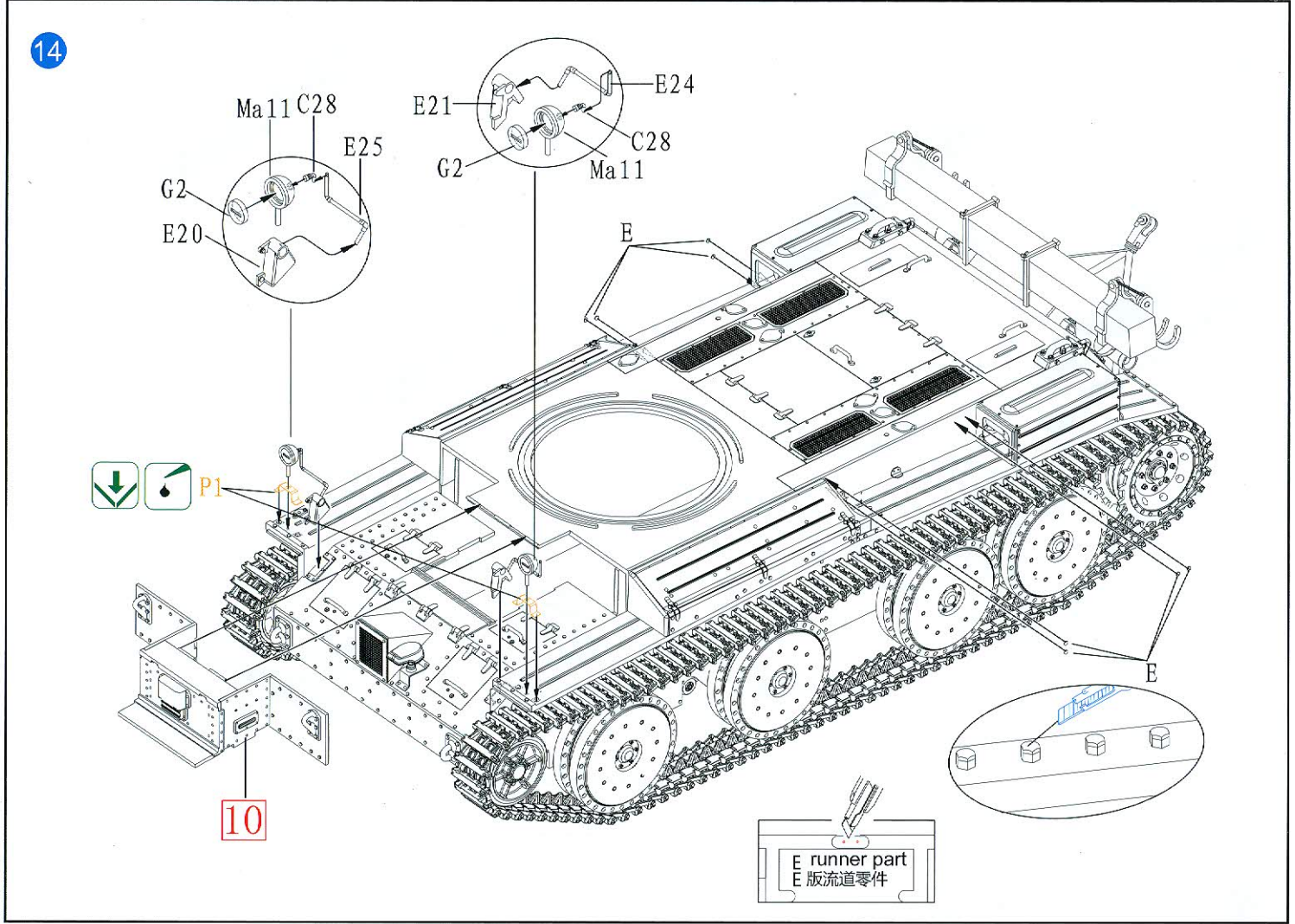

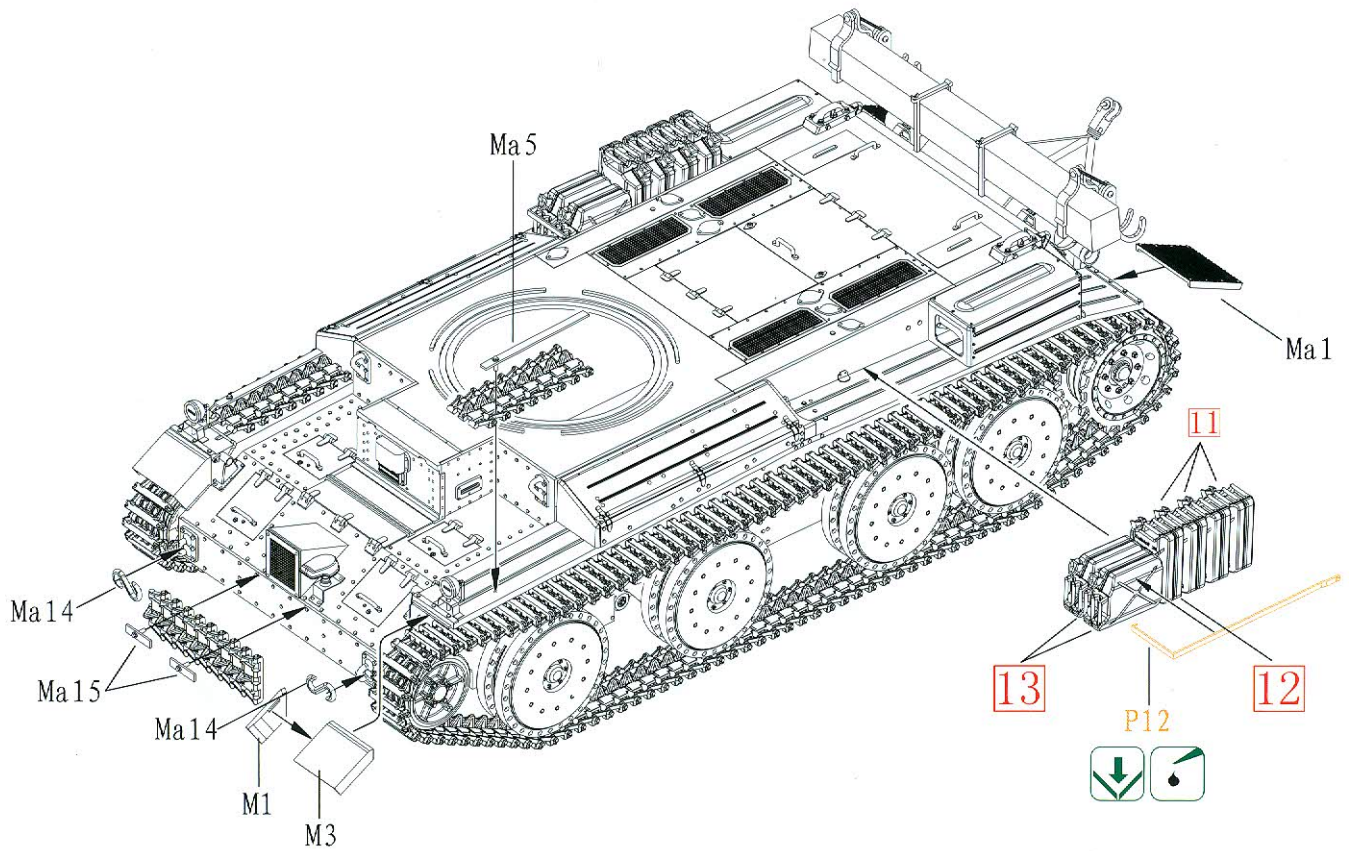

ILLUSTRATION 图示说明：





16



17

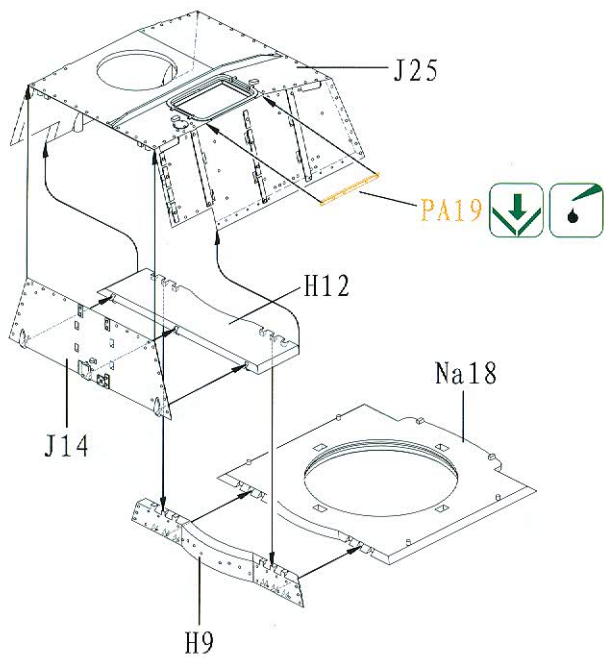

Caution: make the antenna by plastic frame channel with the heat of fire  
 注明: 制作天线用流道加热拉丝

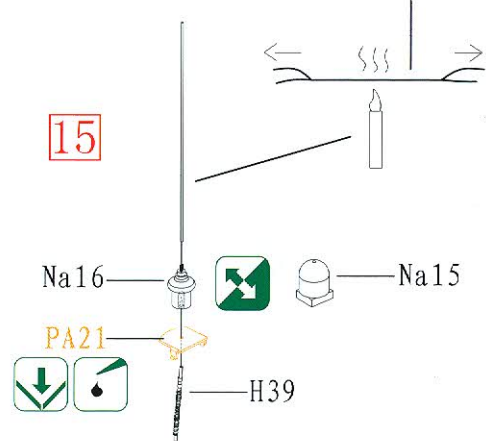

Option for close or open  
 可选择开关

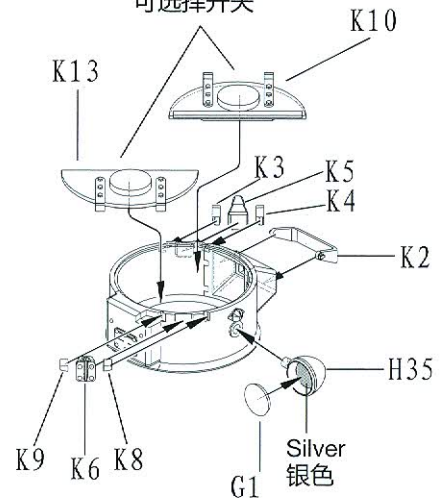
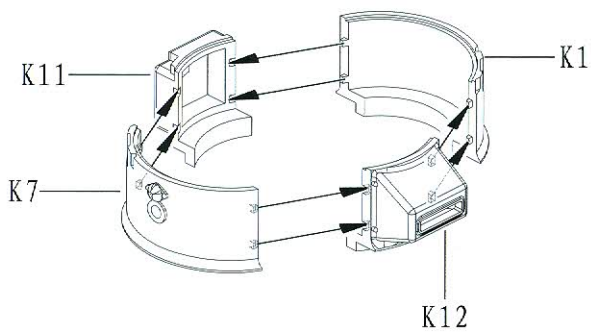

18

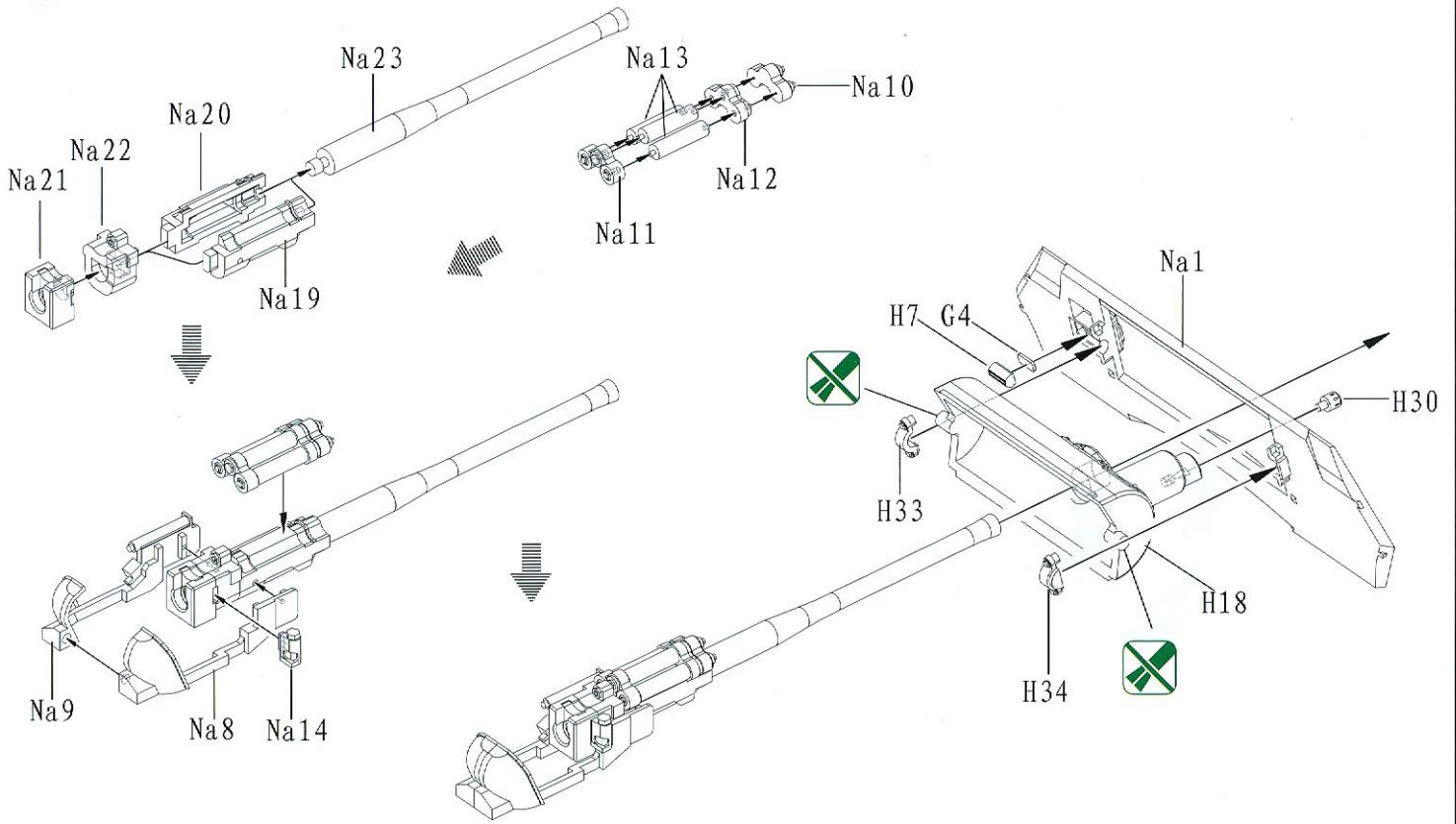

19

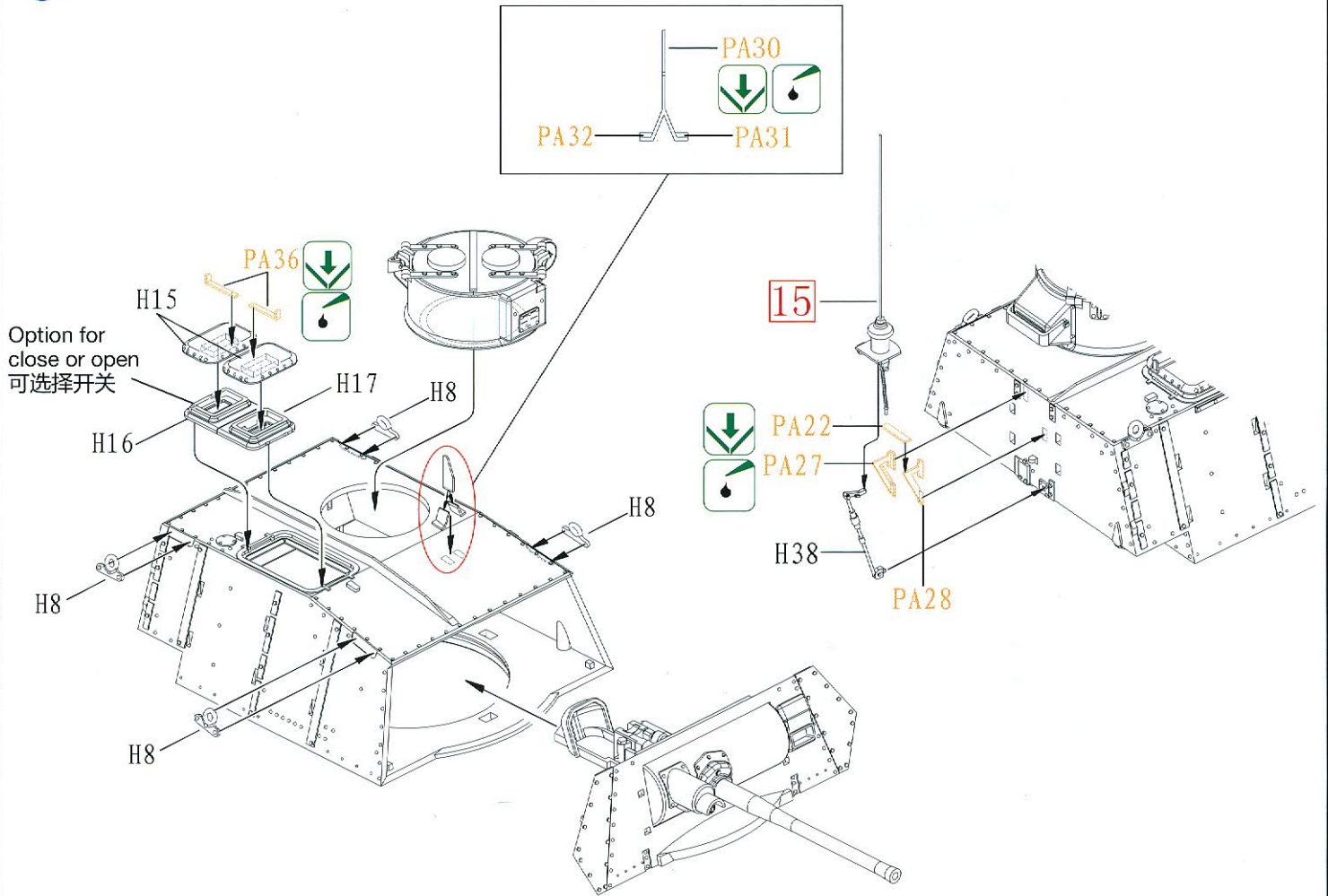

20

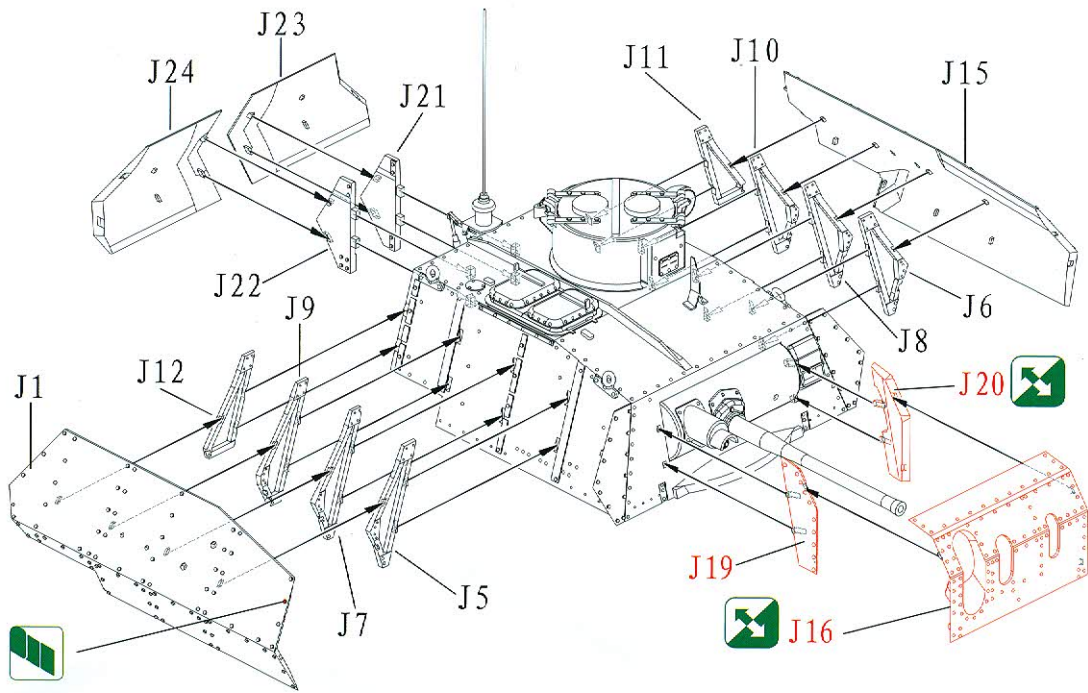

21

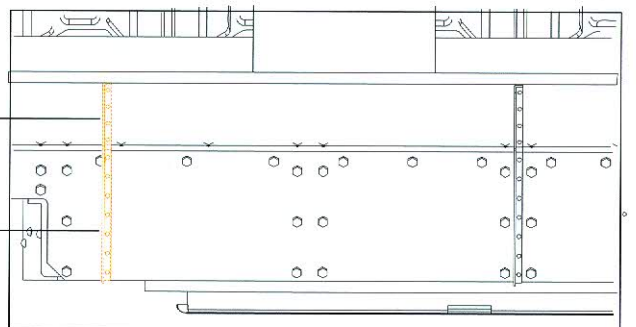
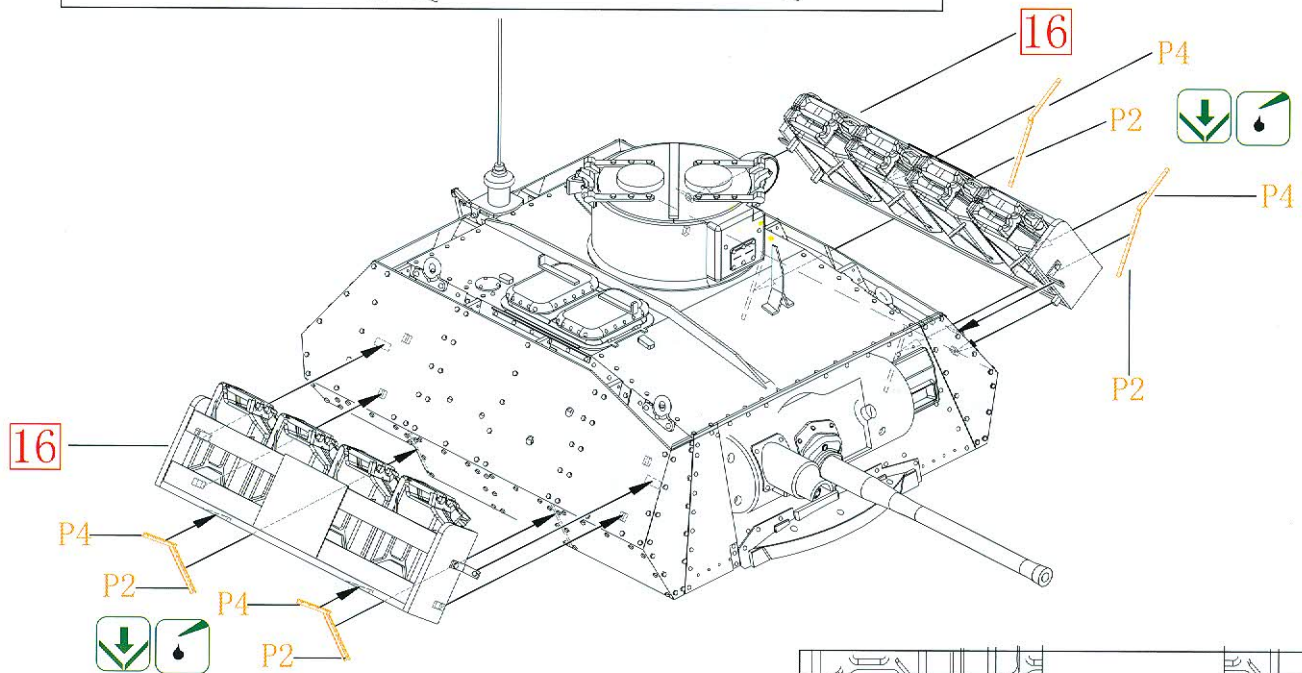
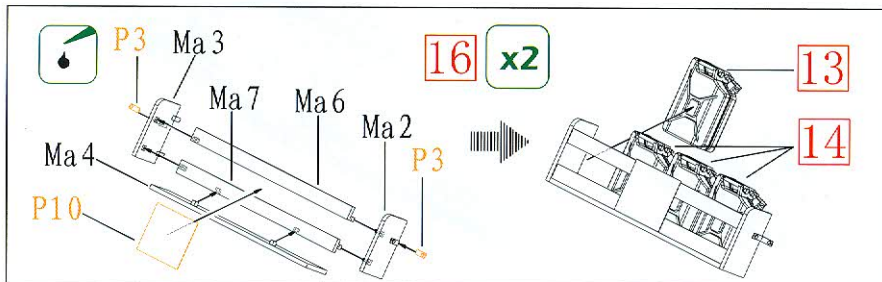

22

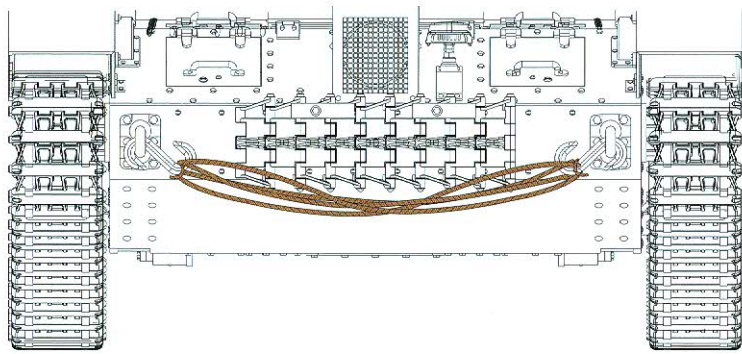
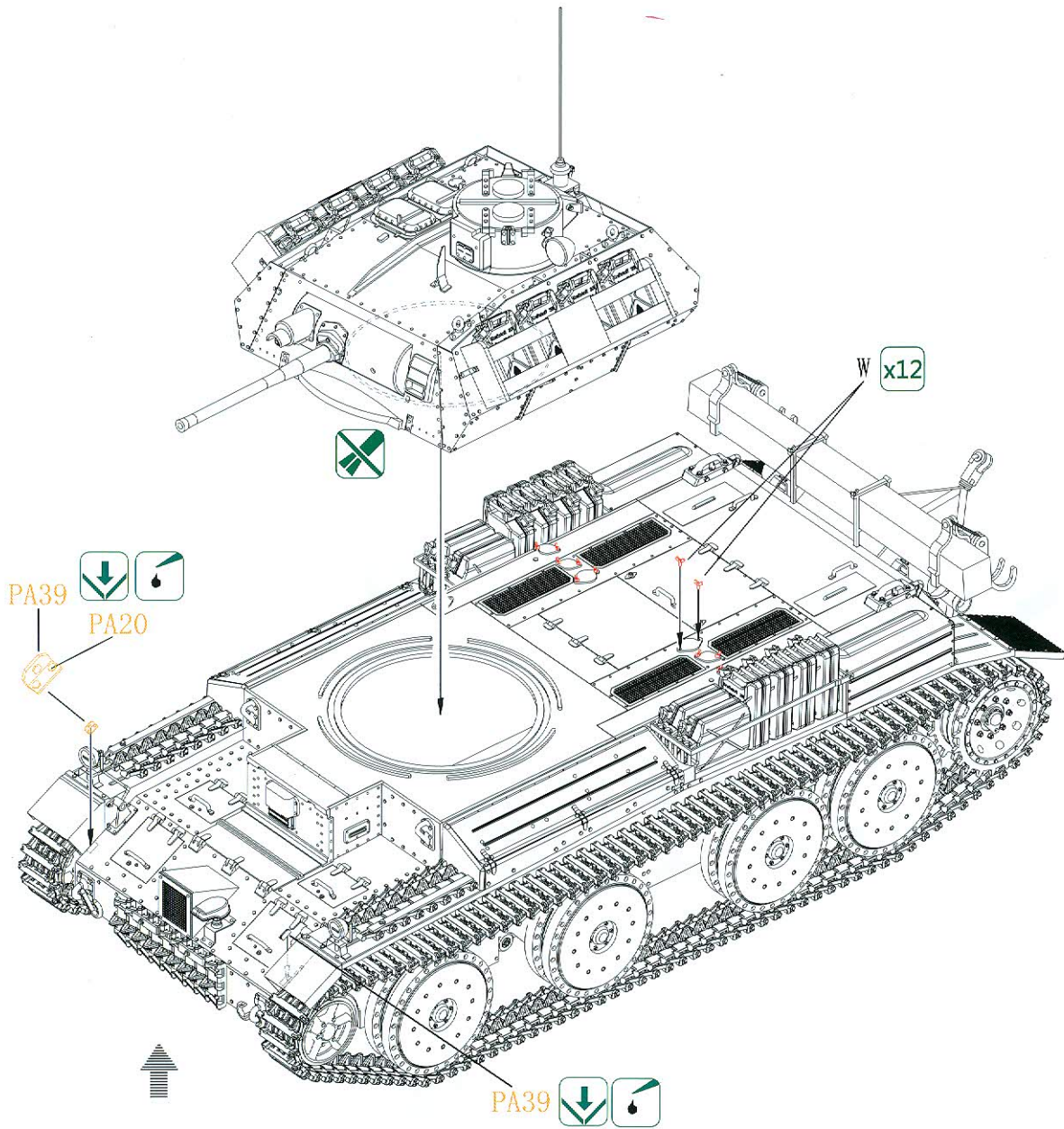

23 UE trailer assembly guide :  
UE拖载车组装说明：

17

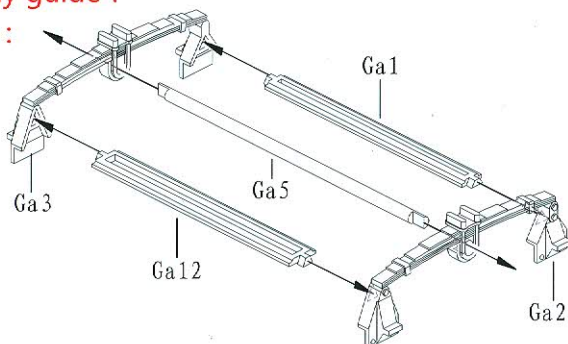

18

x2

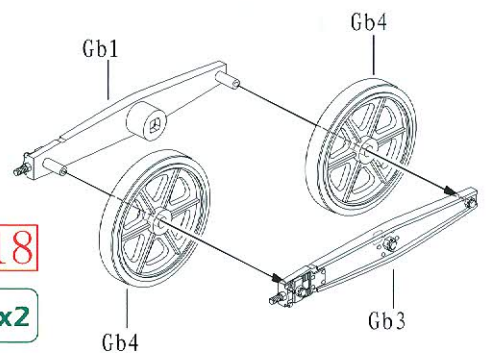
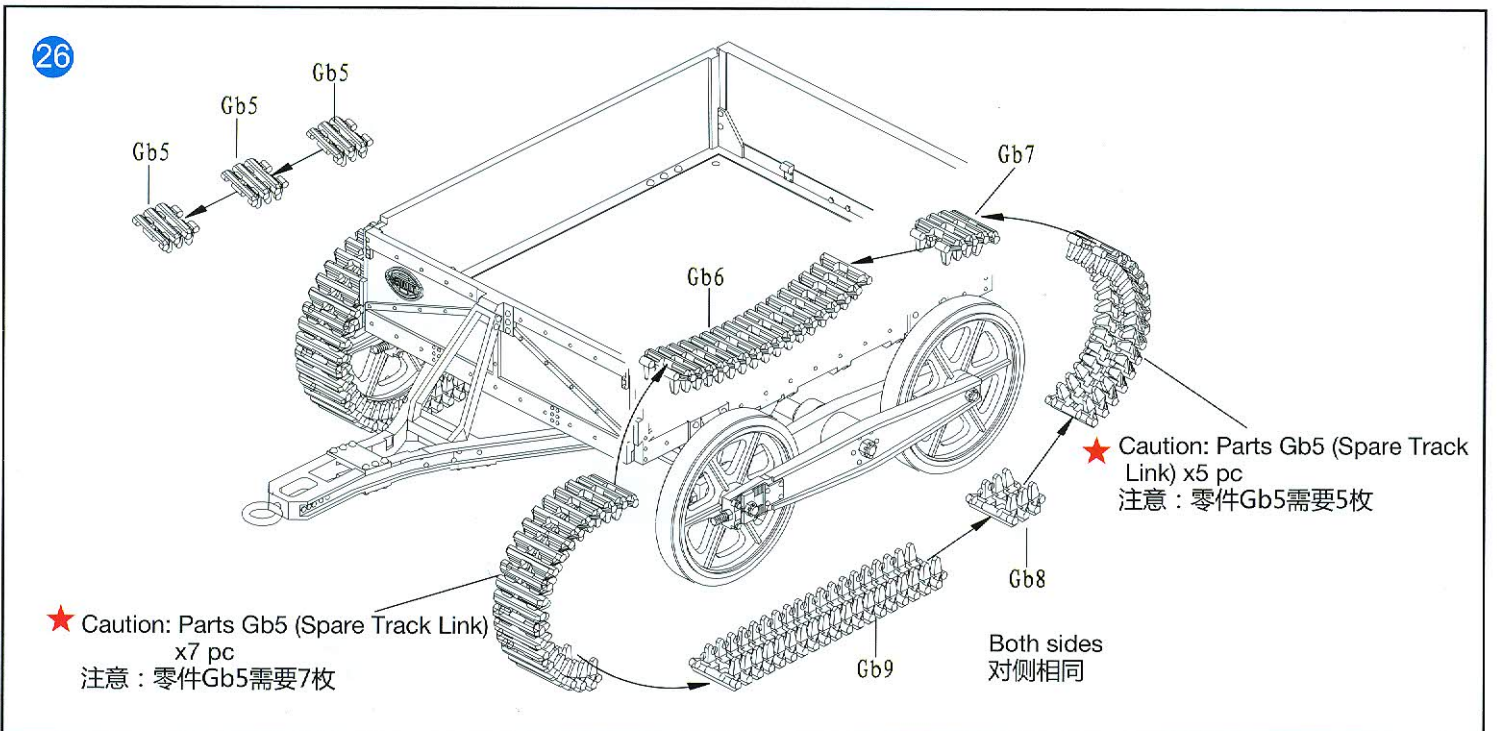
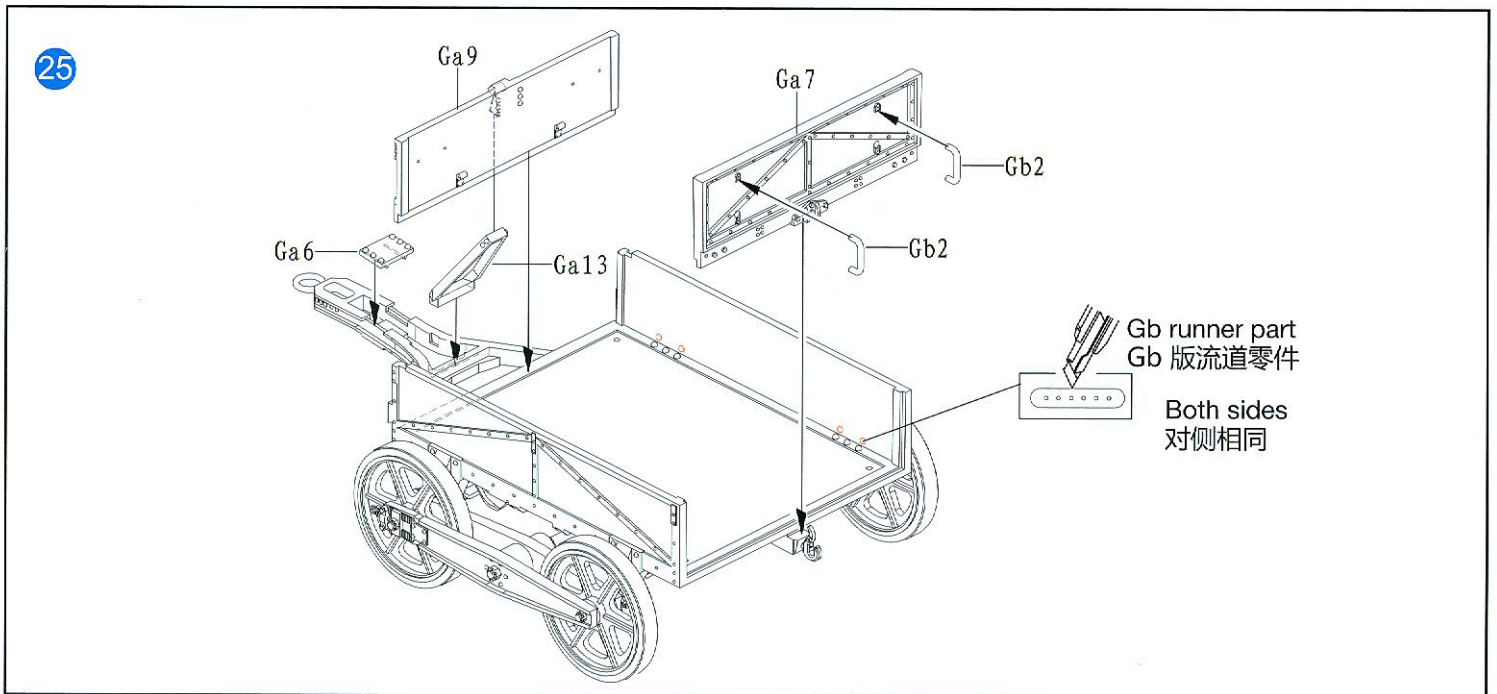
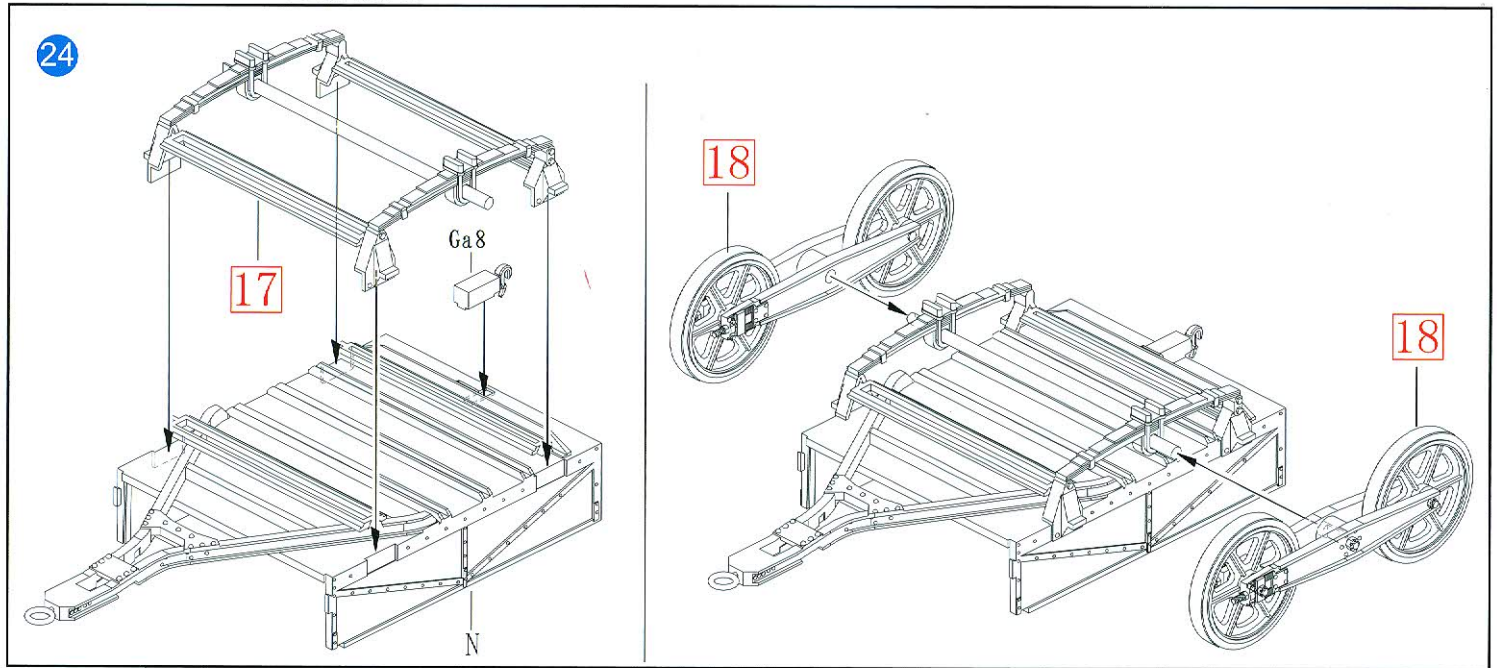

ILLUSTRATION 图示说明：



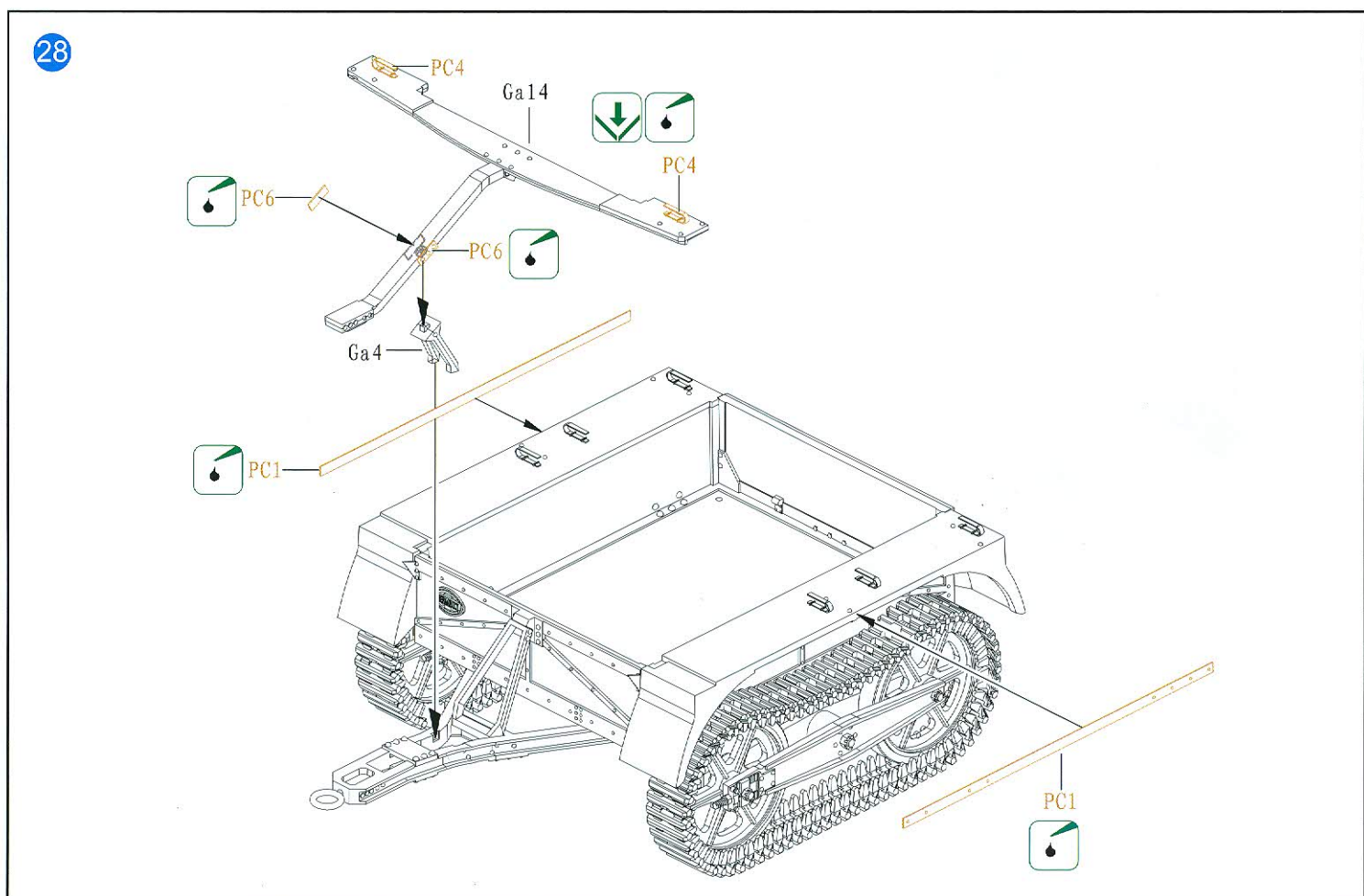
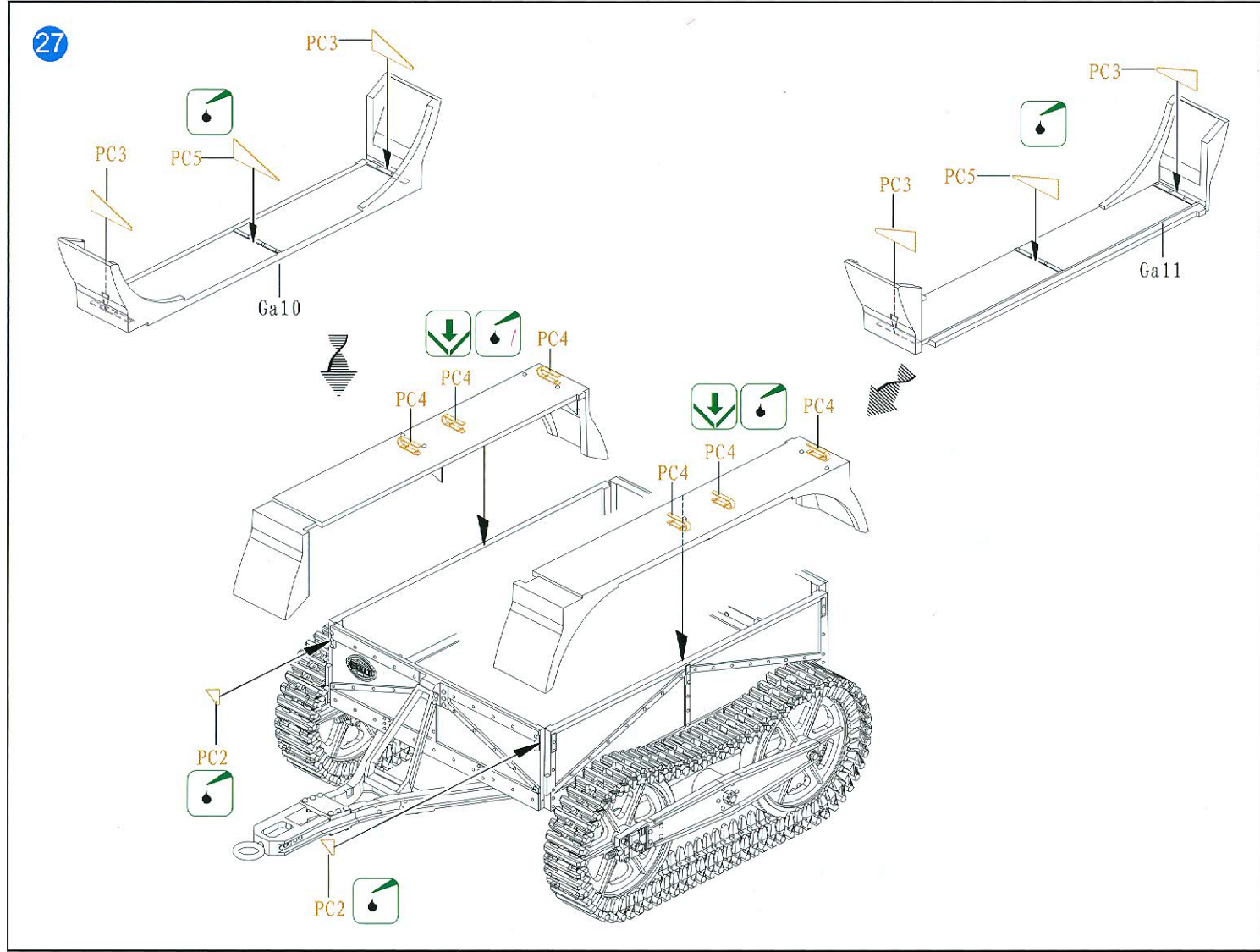
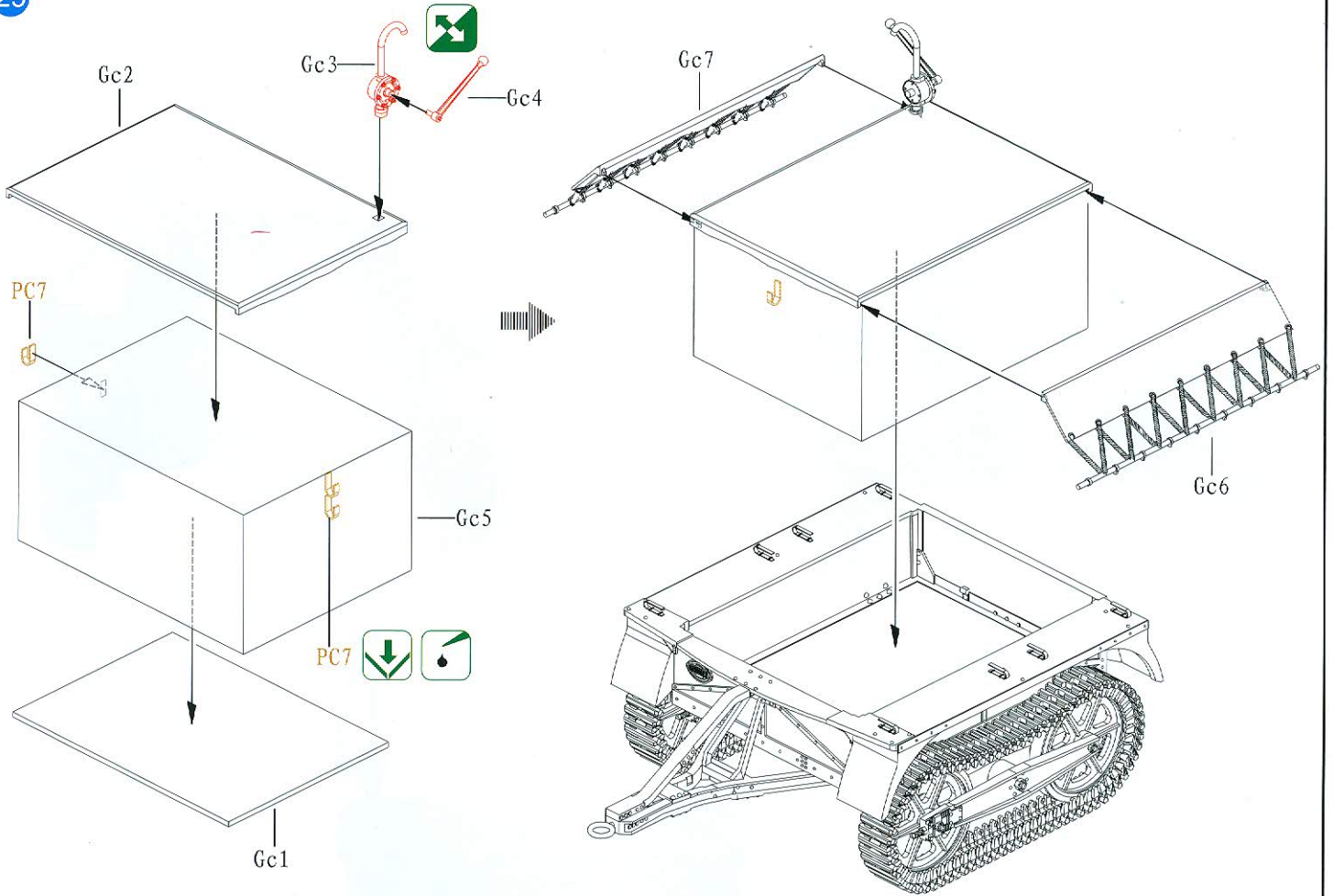

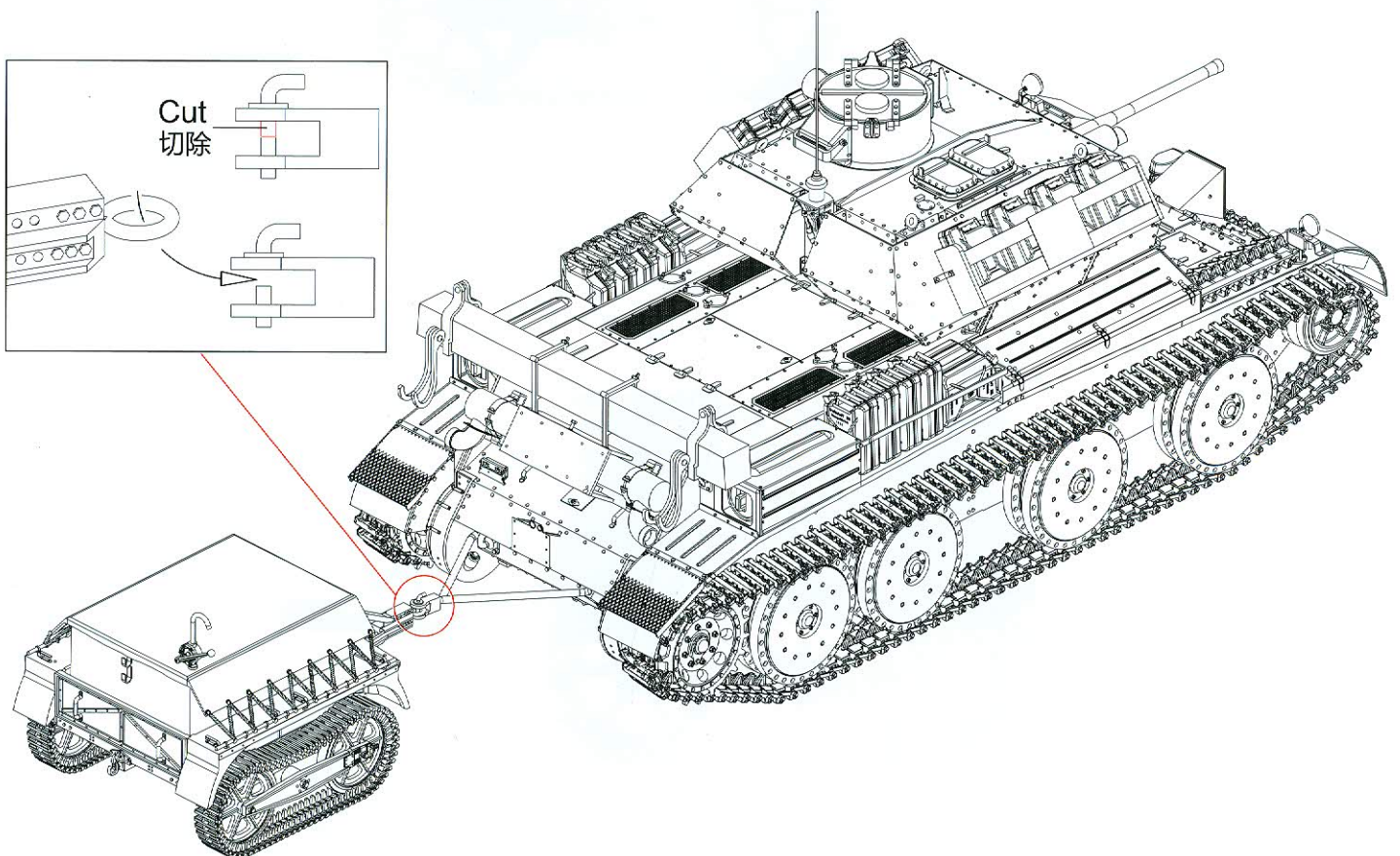

ILLUSTRATION 图示说明：

29



30



# UE Fuel Tank Trailer

UE 供油拖载车



Metallic grey rust  
履带色

German Gray  
德国灰

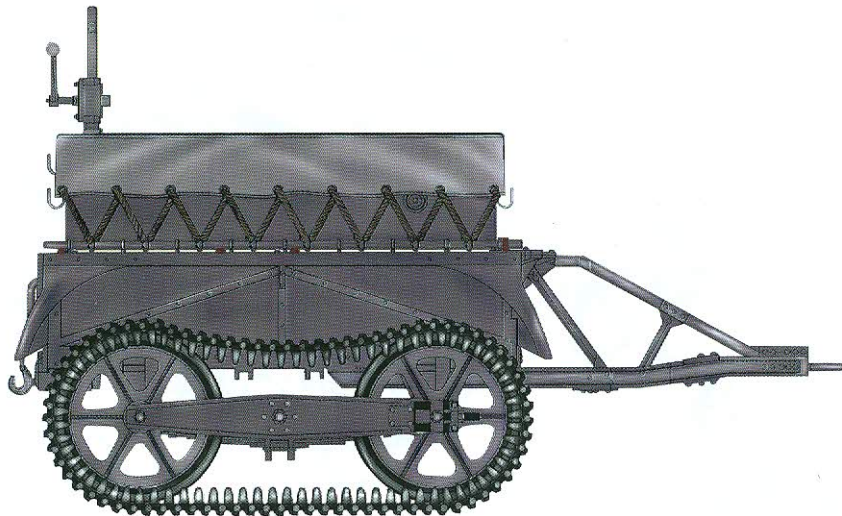
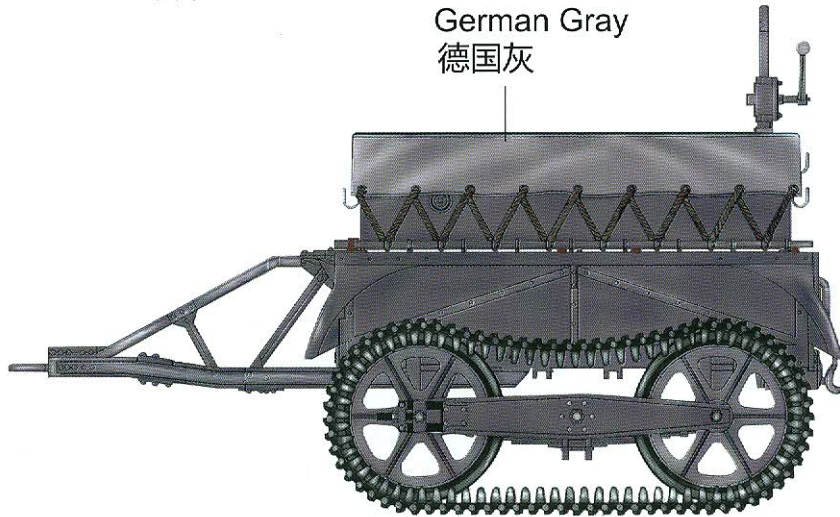

# DECAL&COLOUR GUIDE 水贴及涂色指示：

Option 1 : Pz.Abt.(Flamm) 100,18th Pz. Division, Russia Winter,1941.

1941年在俄国作战之第十八装甲师之第100装甲喷火营属下车辆。

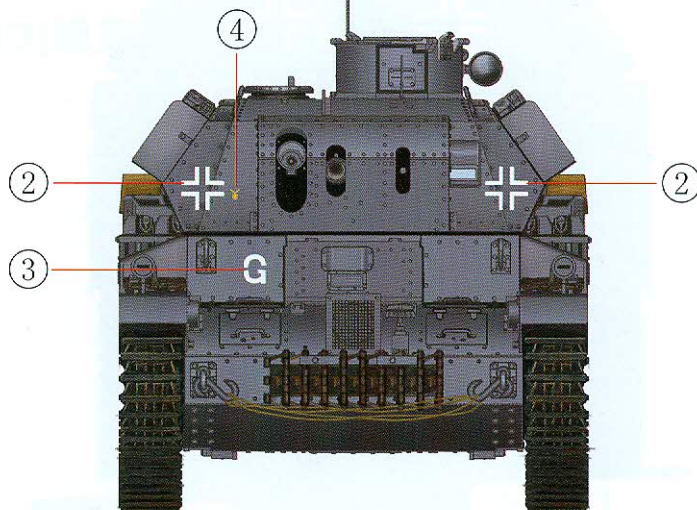
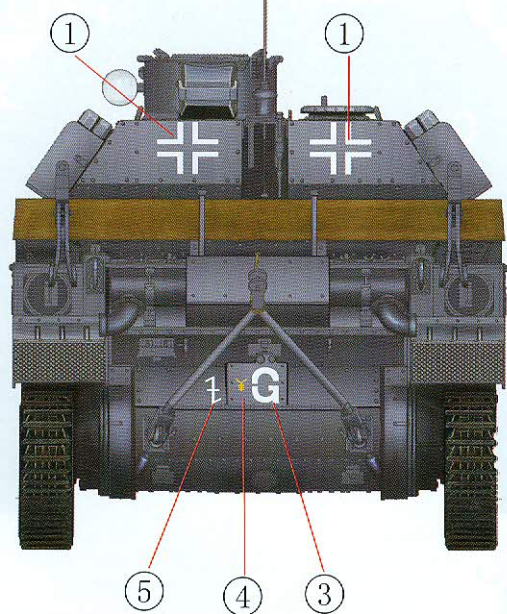

Metallic grey rust  
履带色

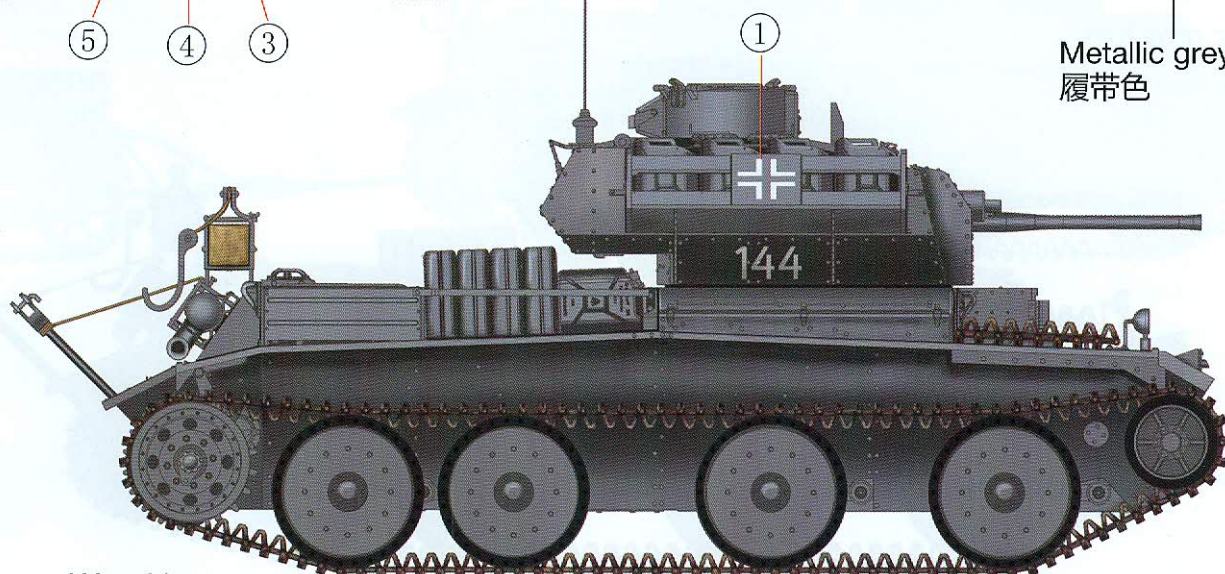

Wood brown  
木棕色

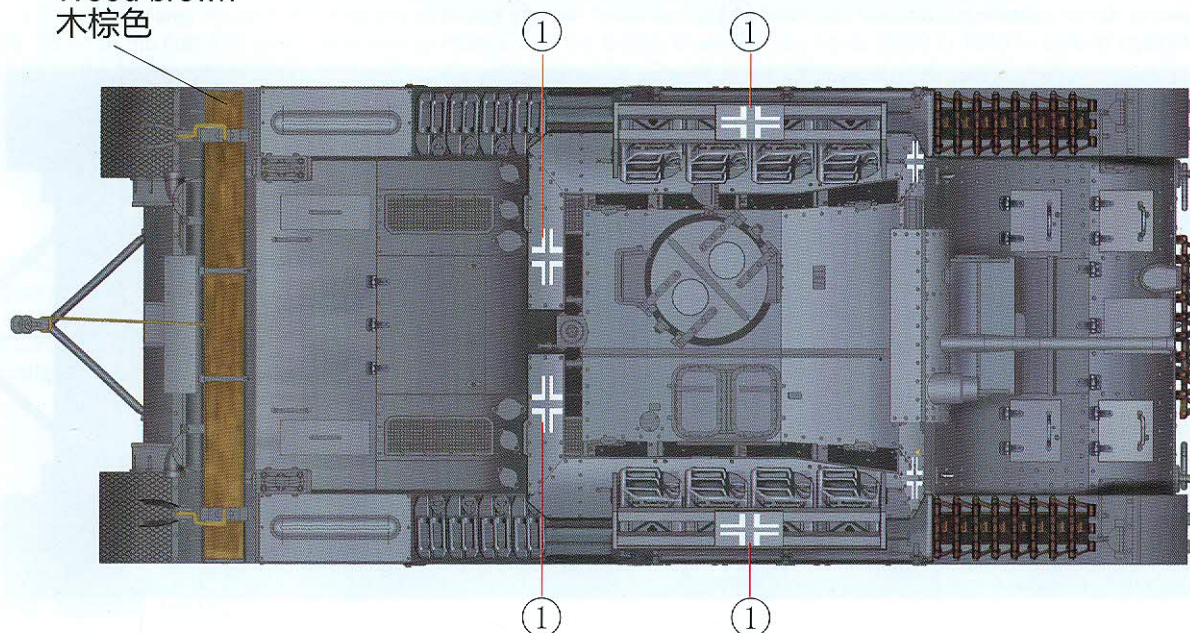

Camouflage Scheme: Overall German Gray

迷彩颜色：全车涂德国灰

Option 2 :

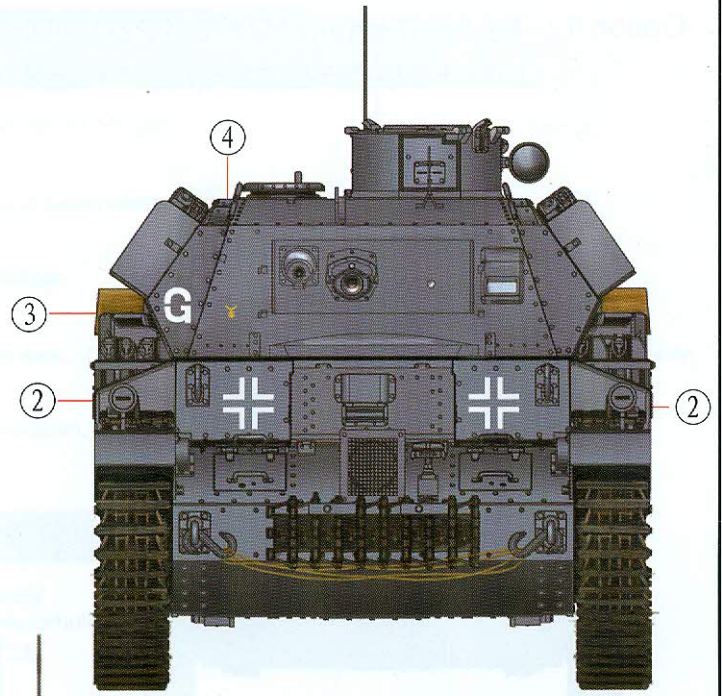
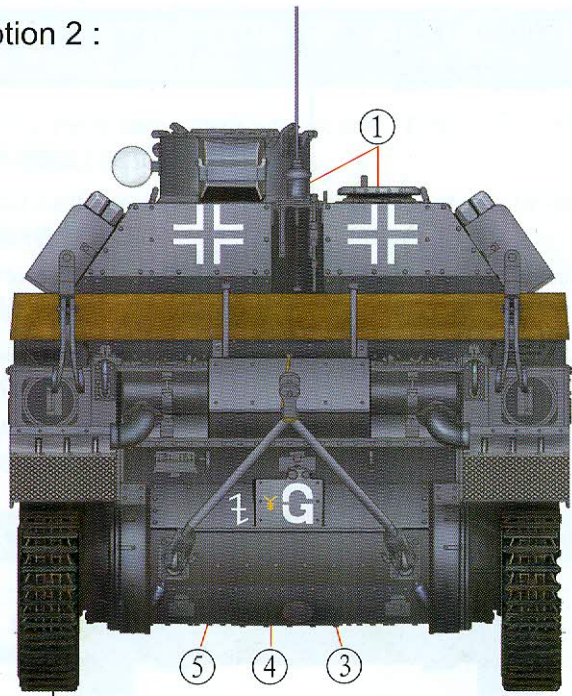

Metallic grey rust  
履带色

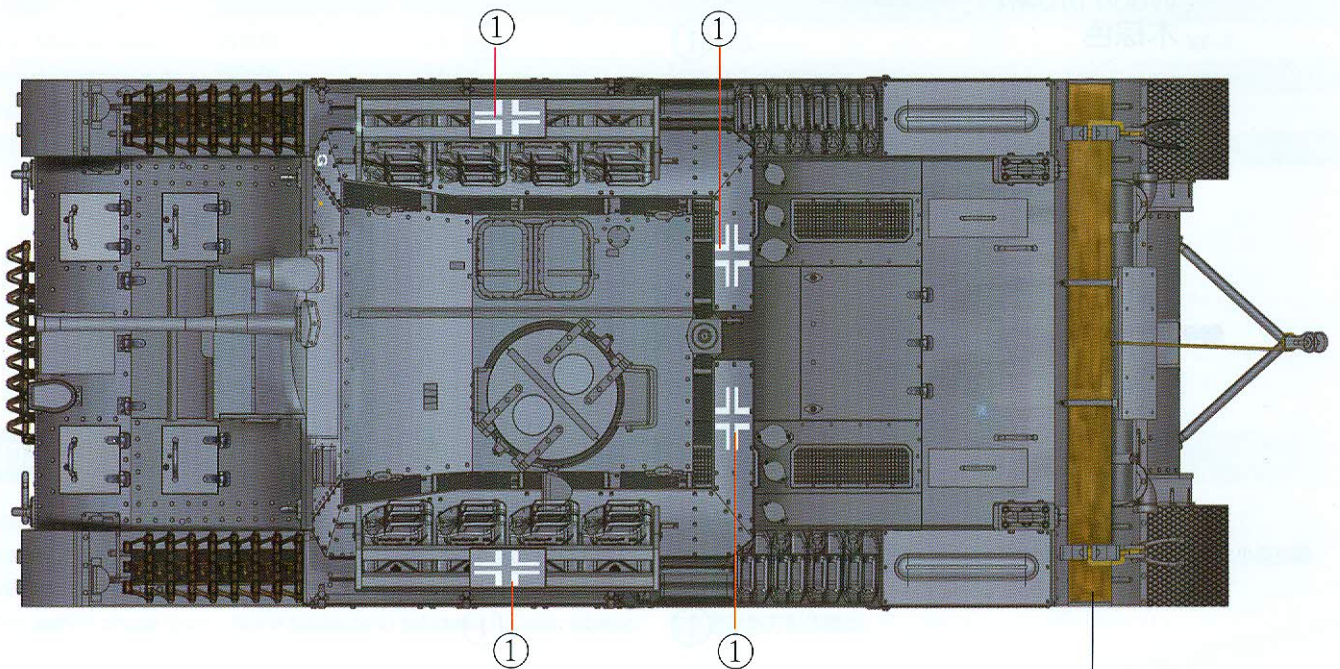
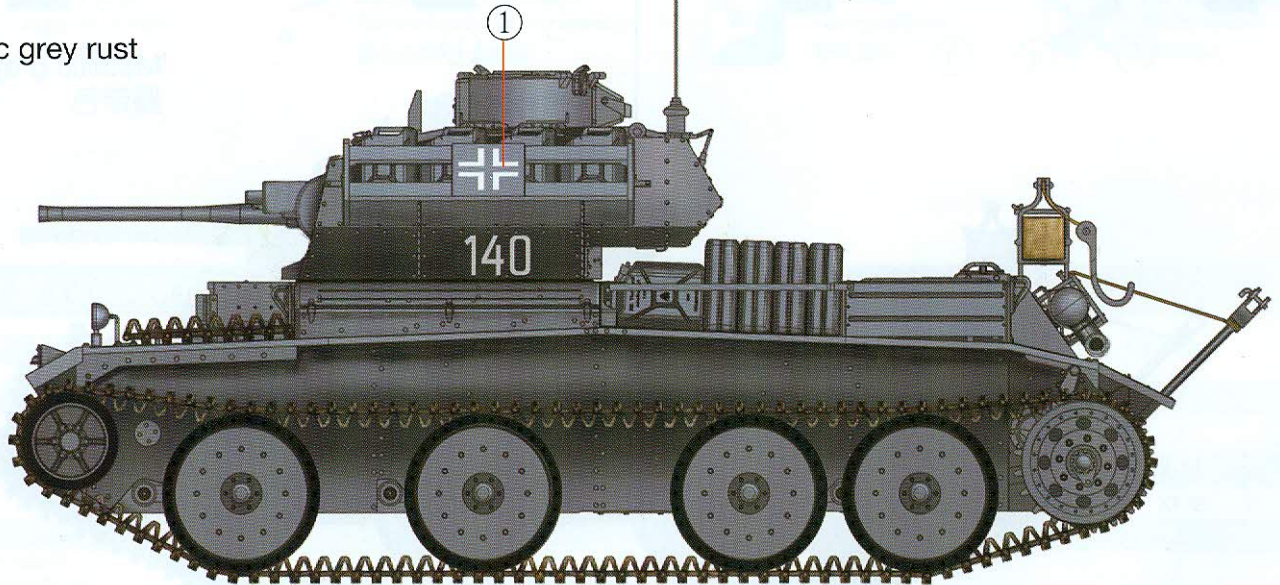

Camouflage Scheme: Overall German Gray  
迷彩颜色：全车德国灰

Wood brown  
木棕色