

# 35 K04T

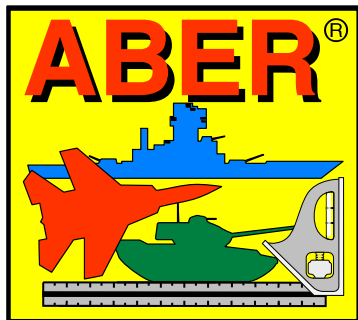

## EXCLUSIVE EDITION

### UPGRADE SET FOR TAKOM 1/35 MODELS

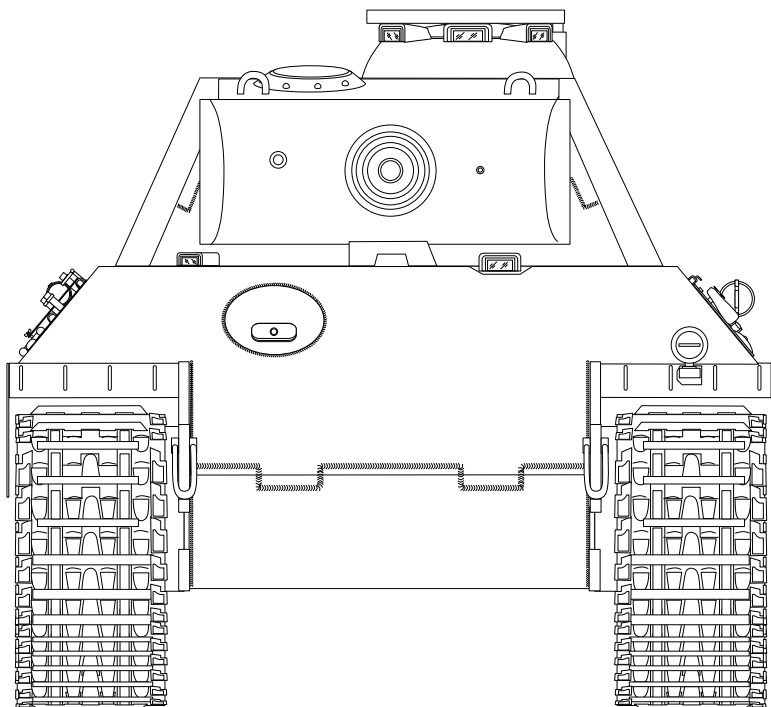

## GERMAN MEDIUM TANK PANTHER G

Pz.Kpfw. V (Sd.Kfz. 171) - Ausf. G

*Niemiecki średni czołg Sd.Kfz. 171 "Panther G"*

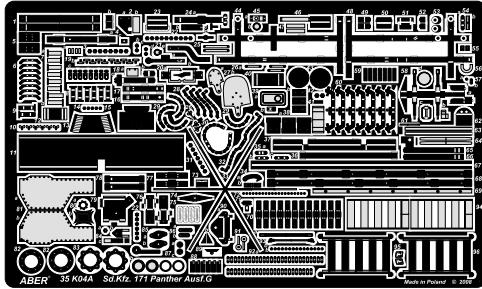
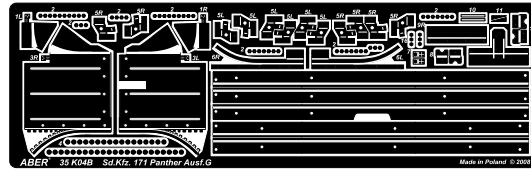
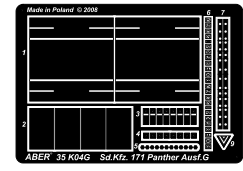
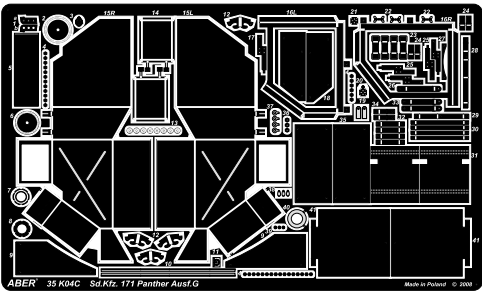
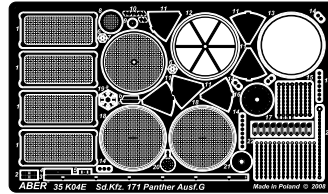
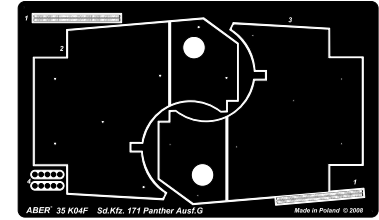
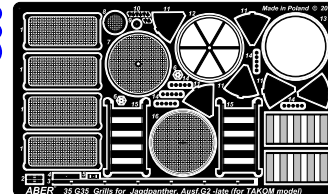
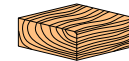
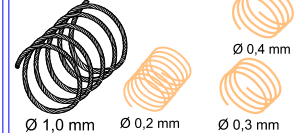
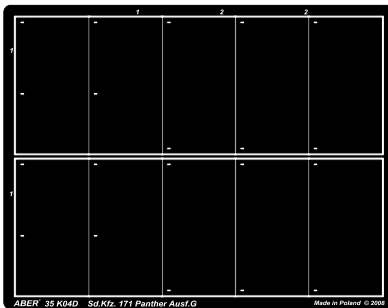
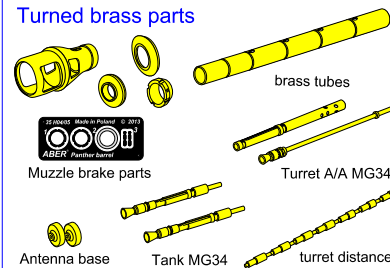
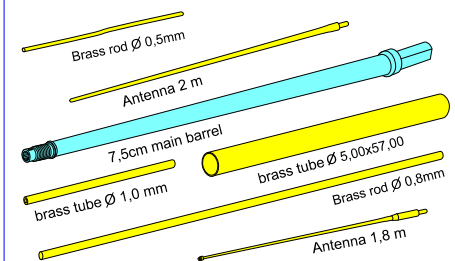
**A****B****G****C****E****F****G35****Bag with wood chock****Bag with cable & wires****D****Turned brass parts****Bag with barrel, antennas, tubes and rods**

## MOST IMPORTANT BIBLIGRAPHY:

- 1) Sd.Kfz.171; Pz.Kpfw.V PANTHER - Waldemar Trojca - "Trojca" ©2003
- 2) Achtung Panzer No.4 - PANTHER, Jagdpanther & Brummbär by Mitsuru Bitoh - Dai Nippon Kaiga Co.,Ltd. ©1994
- 3) GROUND POWER No.024, 079 - Delta Publishing Co.,Ltd. ©1996, ©2000
- 4) Militärfahrzeuge Band 9; Der Panzer-Kampfwagen Panther und Seine Abarten - Walter J. Spielberger - Motorbuch ©1994
- 5) Panther in Detail - B. Culver & U. Feist - Ryton Publications ©1998
- 6) Panzer Tracts No.5-3 - Thomas L. Jentz & Hilary Louis Doyle
- 7) New Vanguard 22: PANTHER VARIANTS 1942-1945 - Osprey Military ©1997
- 8) AFV Modeling Guide Vol.3 PANTHER - Geibun Mooks ©2009
- 9) Military Detail Illustration Panzerkampfwagen V PANTHER -Shingensha Co Ltd ©2014
- 10) The Research Squad = Panther Project - Vol. 1 and 2 and next

Thank you for purchase our set 35 **K04T**

Read carefully this instruction. Scour metal parts before using  
We advise that better method to join metal to metal parts is soldering.  
Cement metal parts to plastic with good cyanoacryl or epoxy glue.

### WARNING

Any unauthorized copying, producing and reproducing of ABER company products, or any part thereof, is strictly prohibited and any such action establishes liability for a civil action and may give rise to criminal prosecution.

Please note that, for purpose of improvement ABER sets designs are subjects to change without notice.

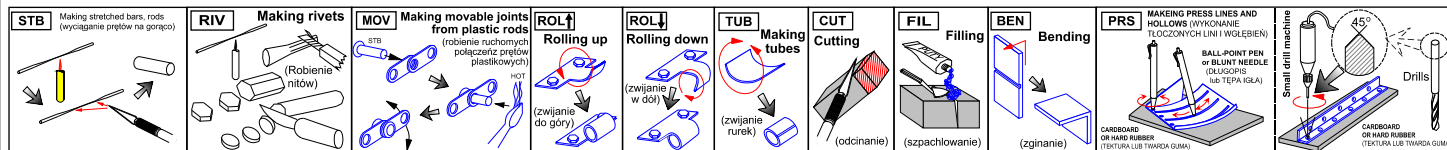

**TOOLS RECOMMENDED**  
Rekomendowane narzędzia

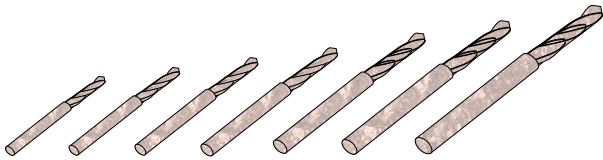

Drills from  $\varnothing$  0,4 to 1,5 mm



Assortment of cutting wheels and mills

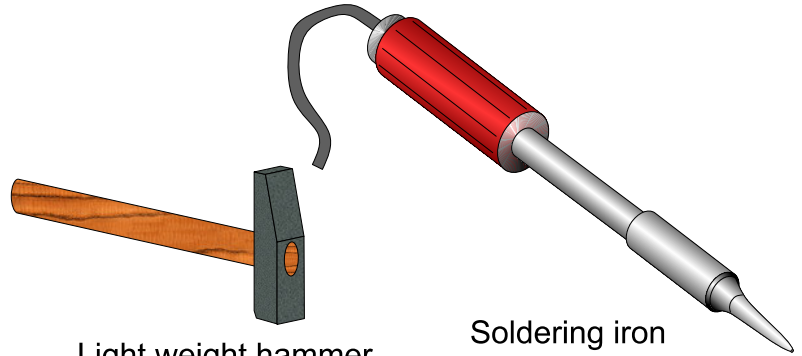

Light weight hammer

Soldering iron

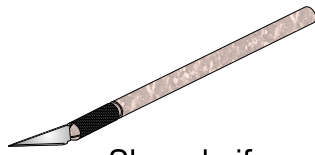

Sharp knife

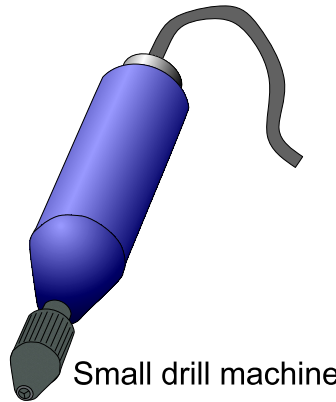

Small drill machine

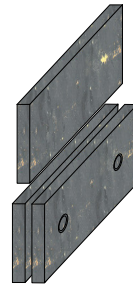

Bending tool  
PG01 or PG02



Soldering flux



Solder

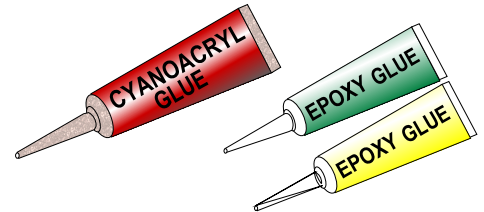

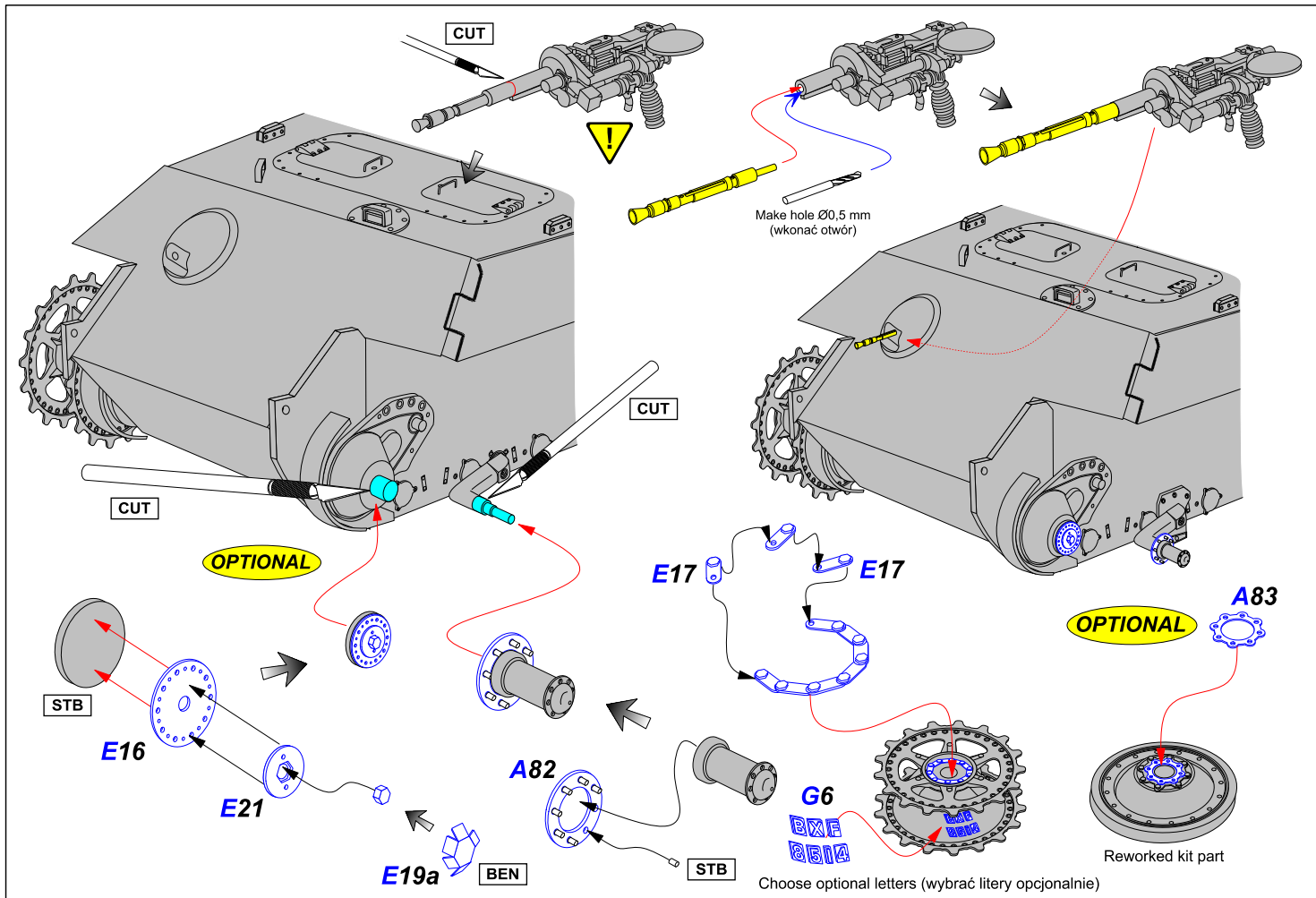

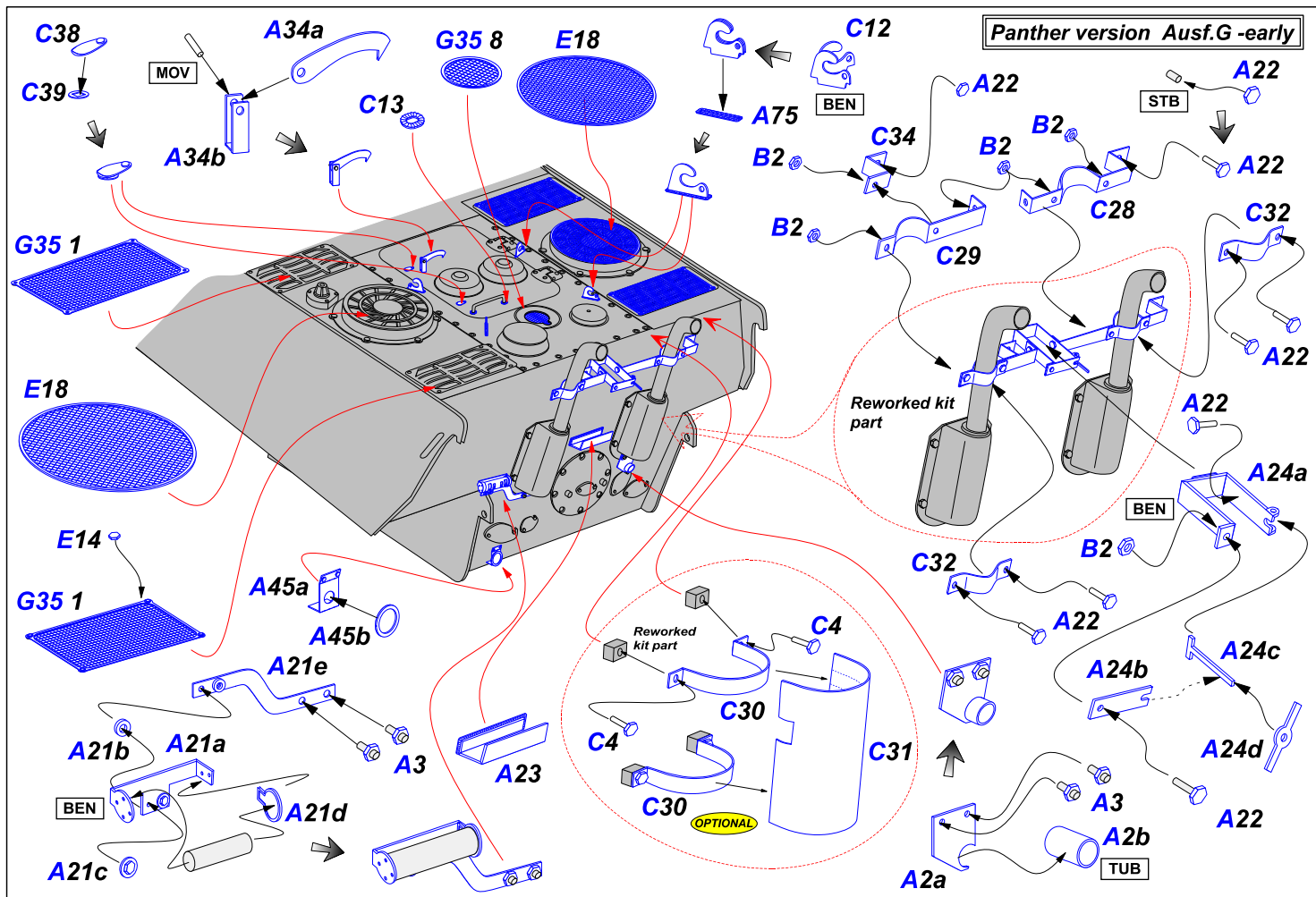

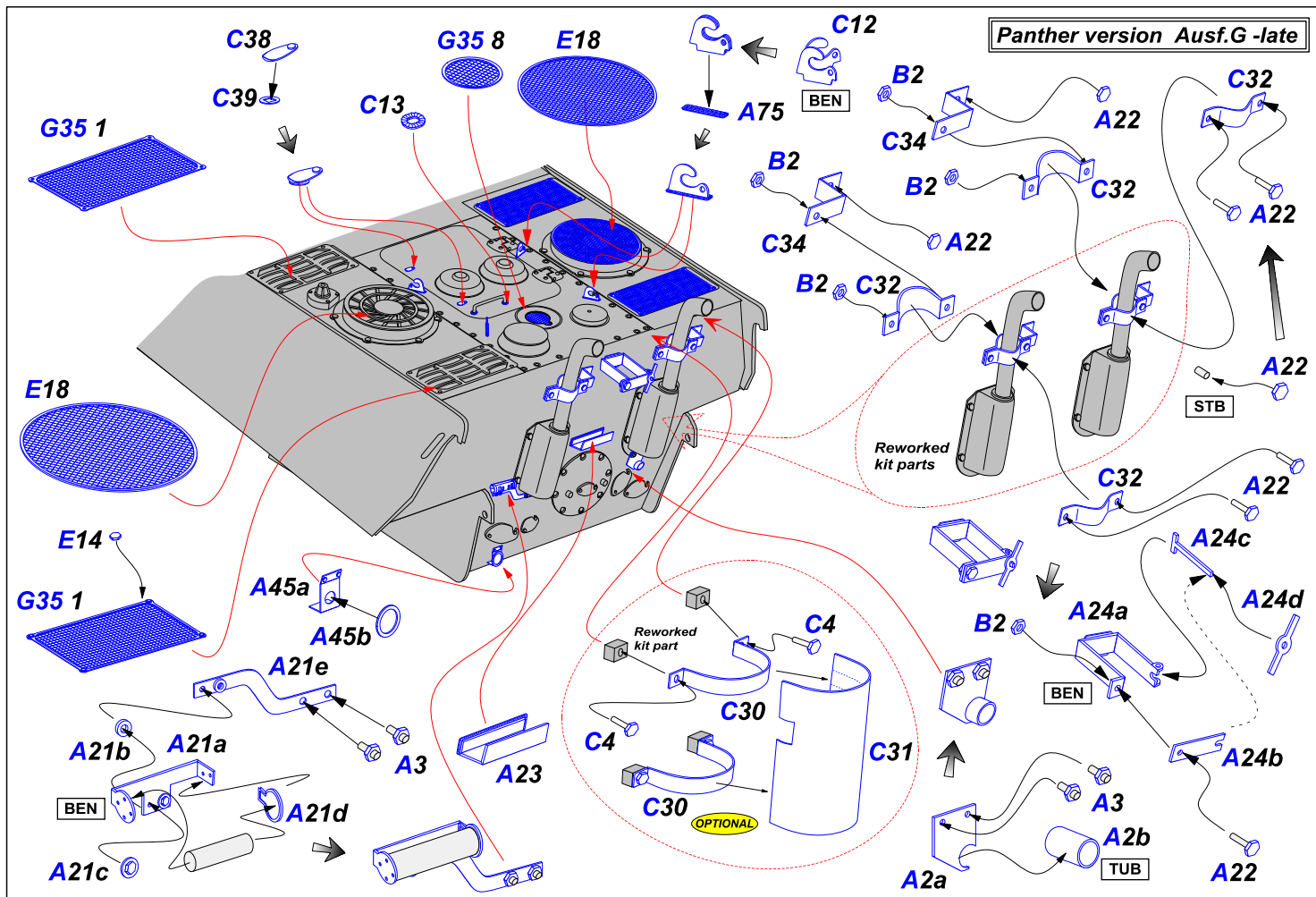

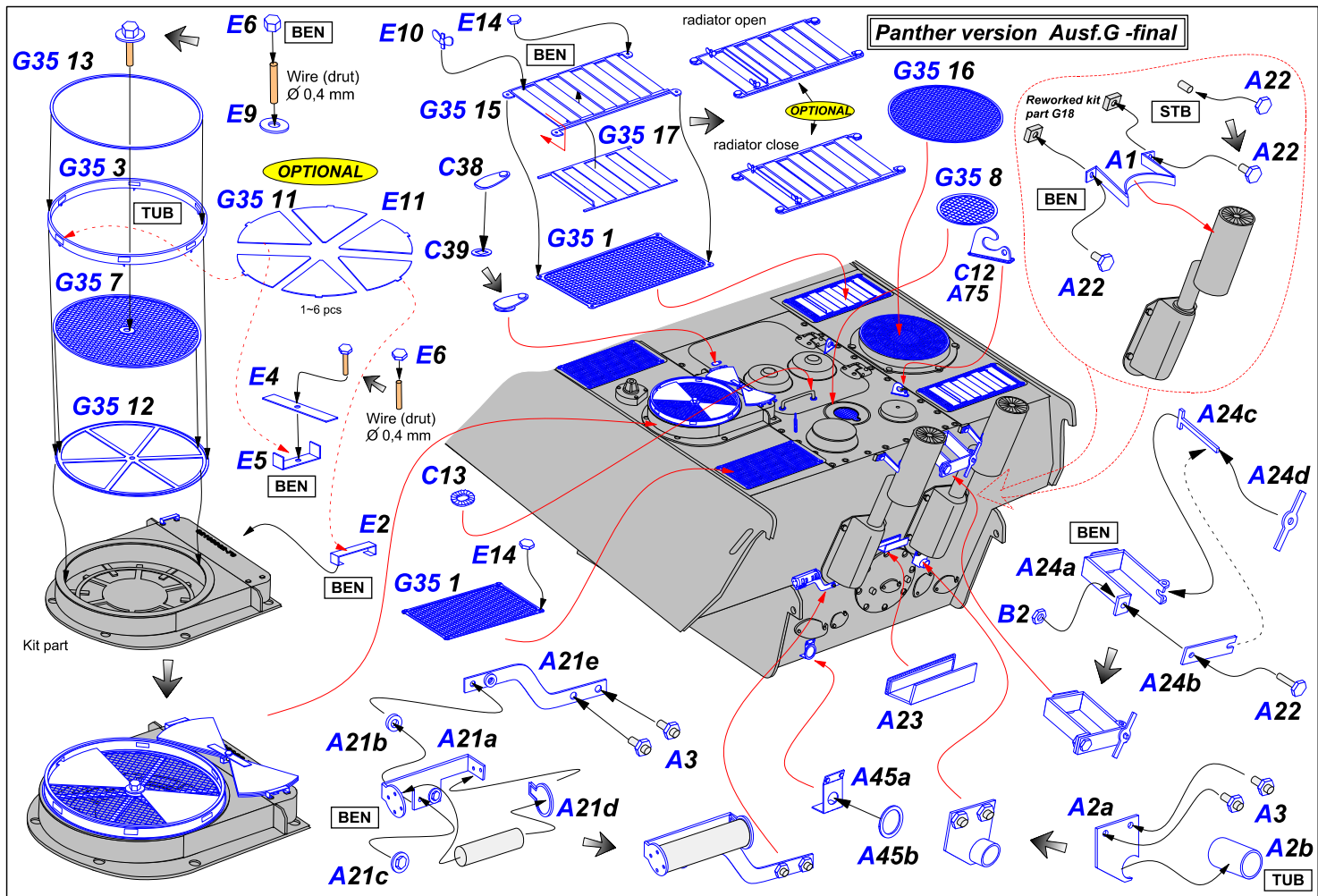



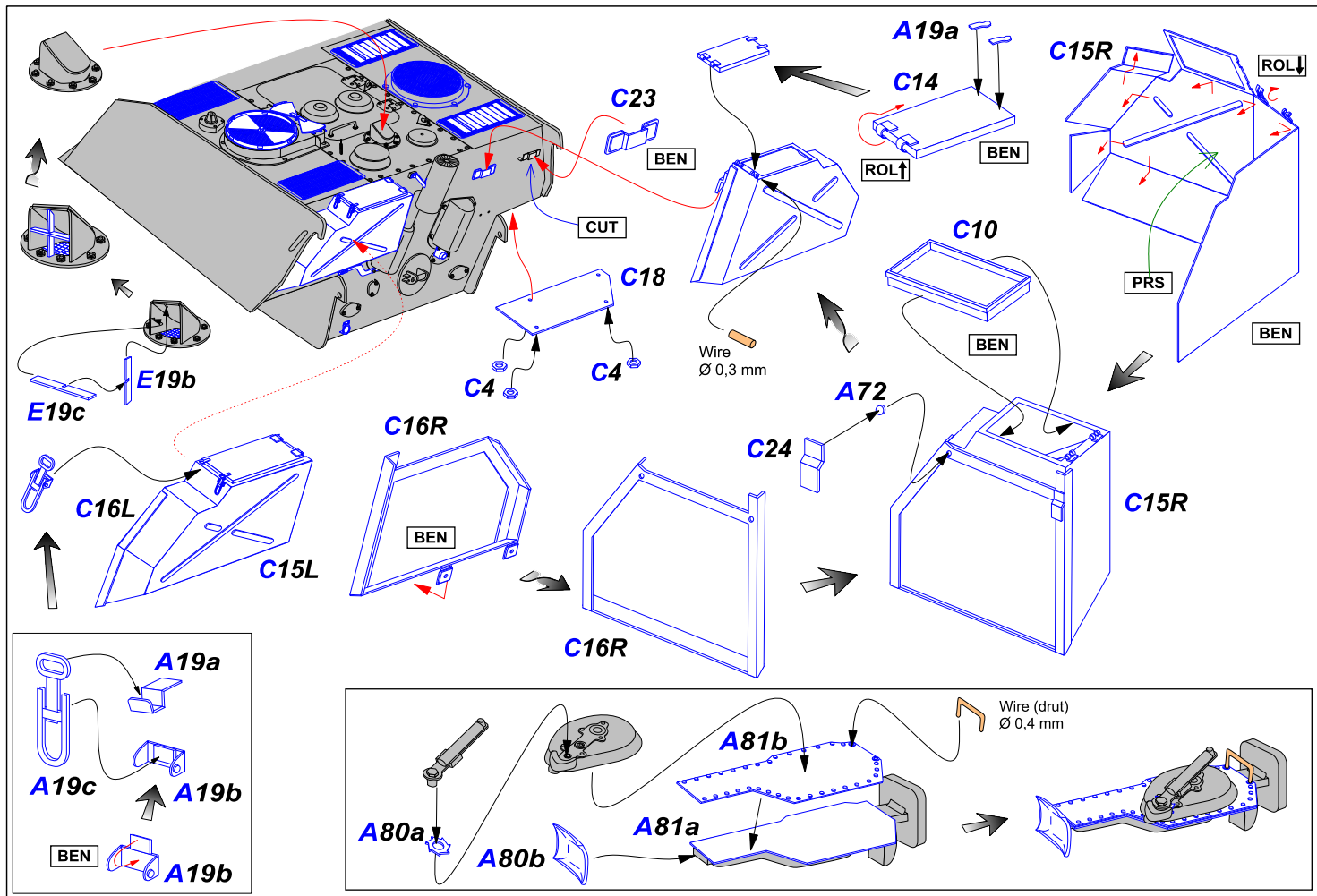

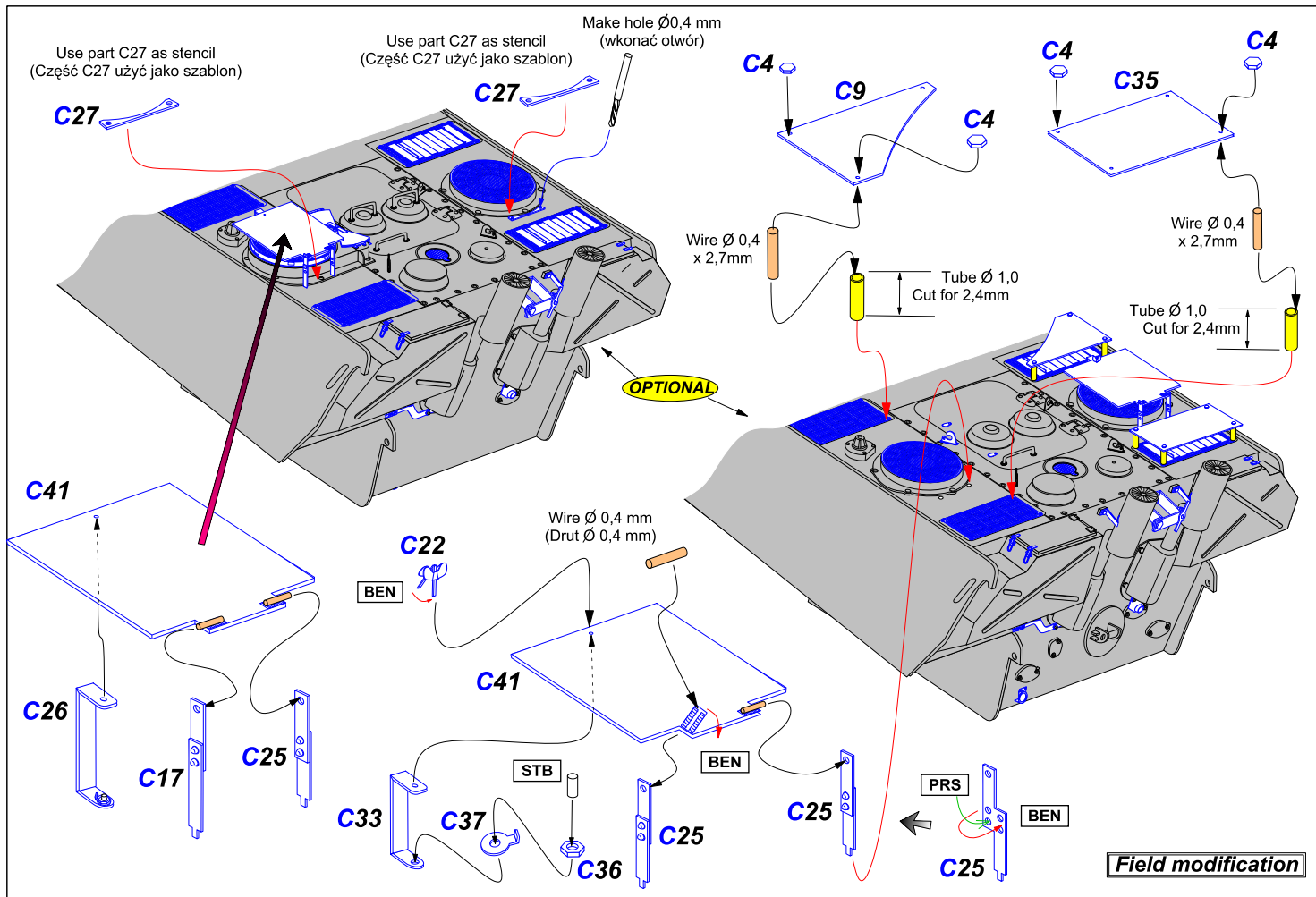

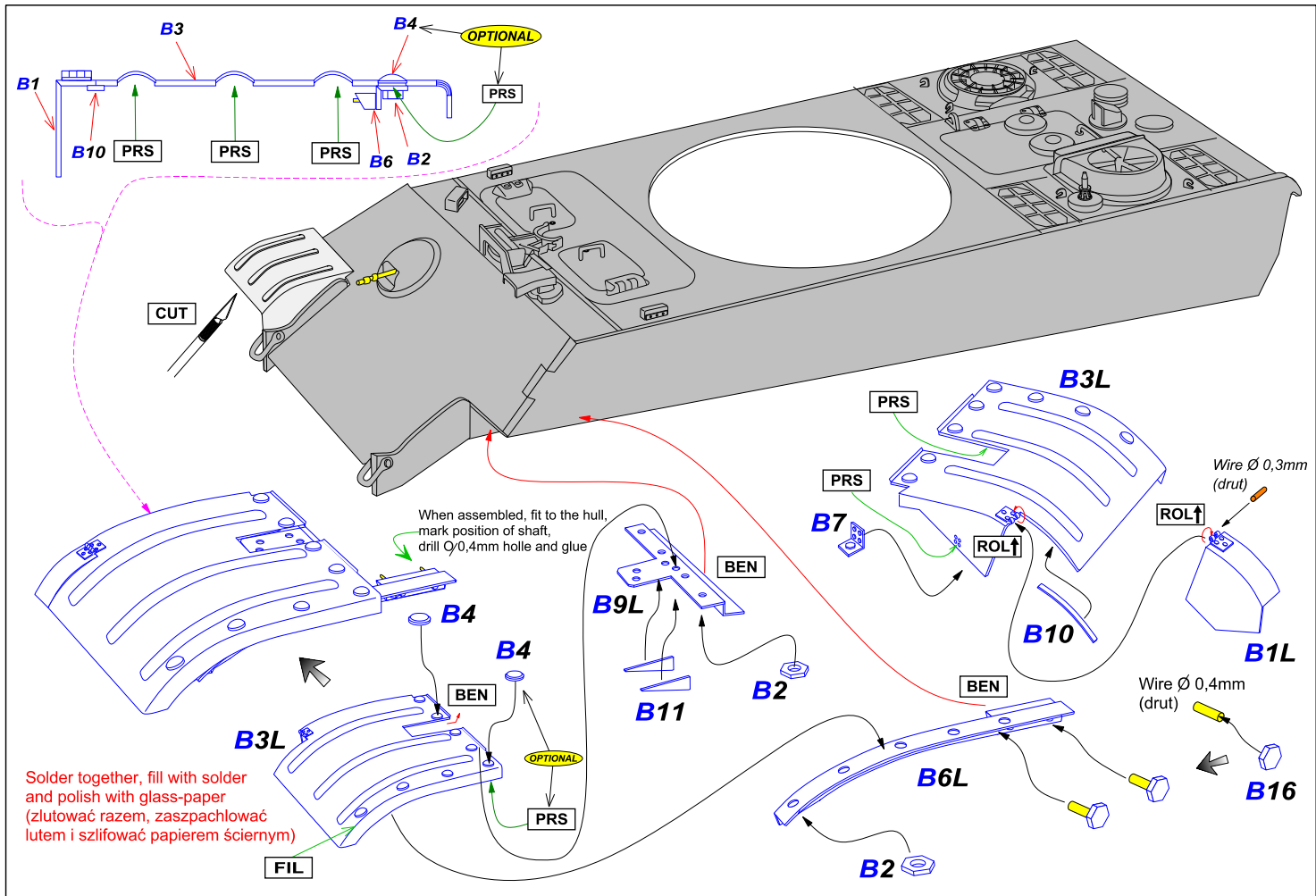

Solder together, fill with solder and polish with glass-paper (złutować razem, zaszpachlować lutem i szlifować papierem ściernym)

When assembled, fit to the hull, mark position of shaft, drill Q=0,4mm hole and glue

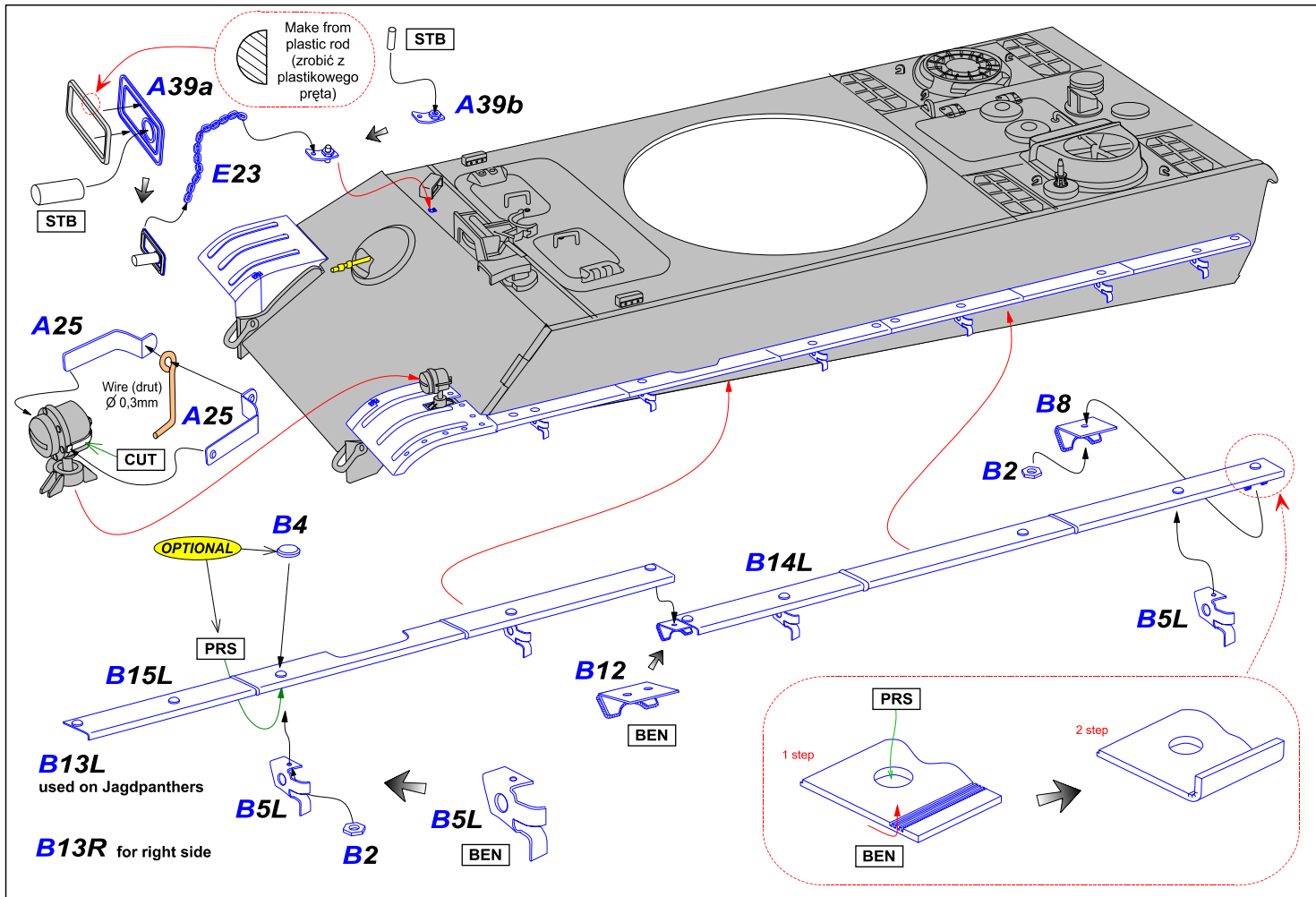

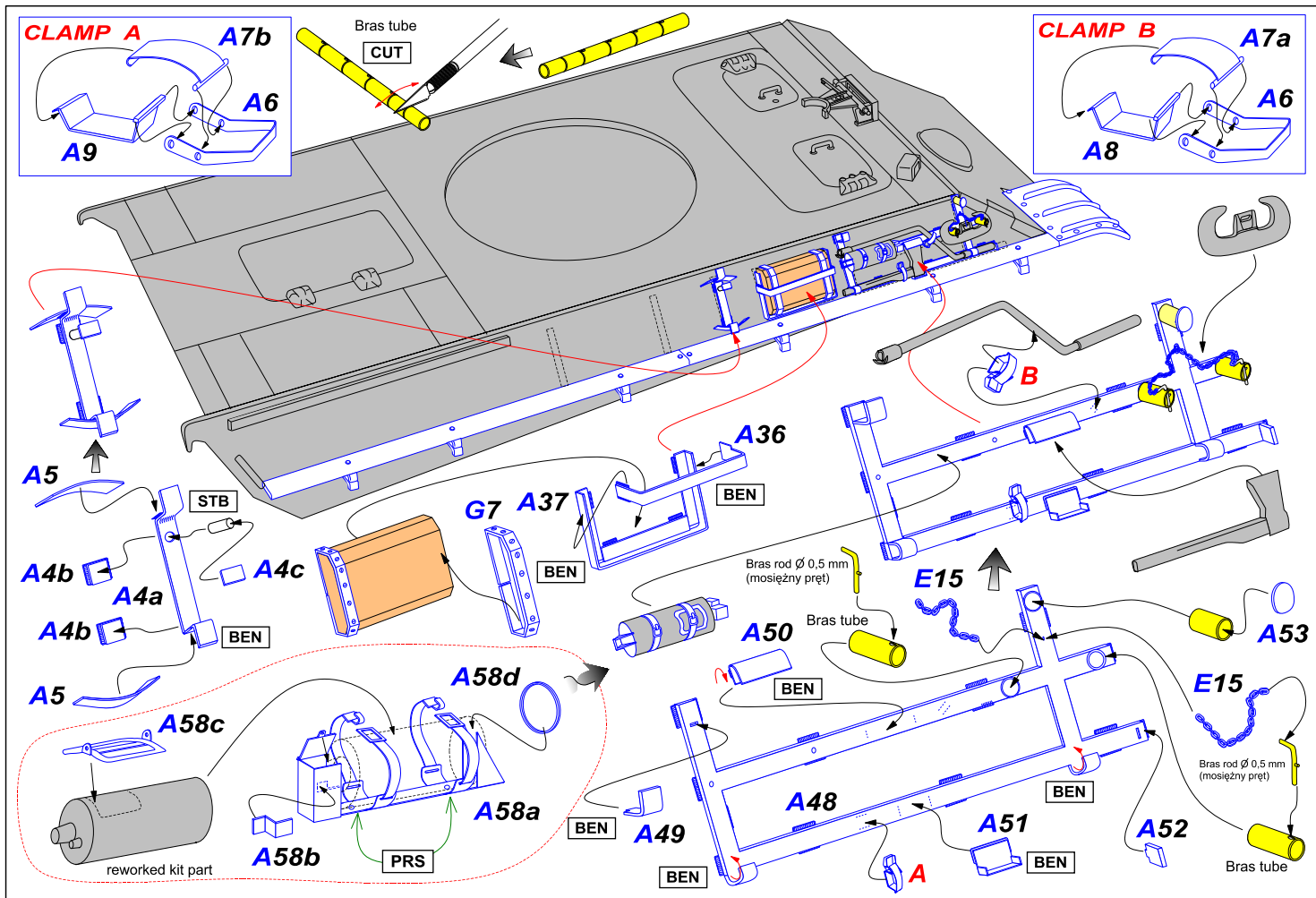

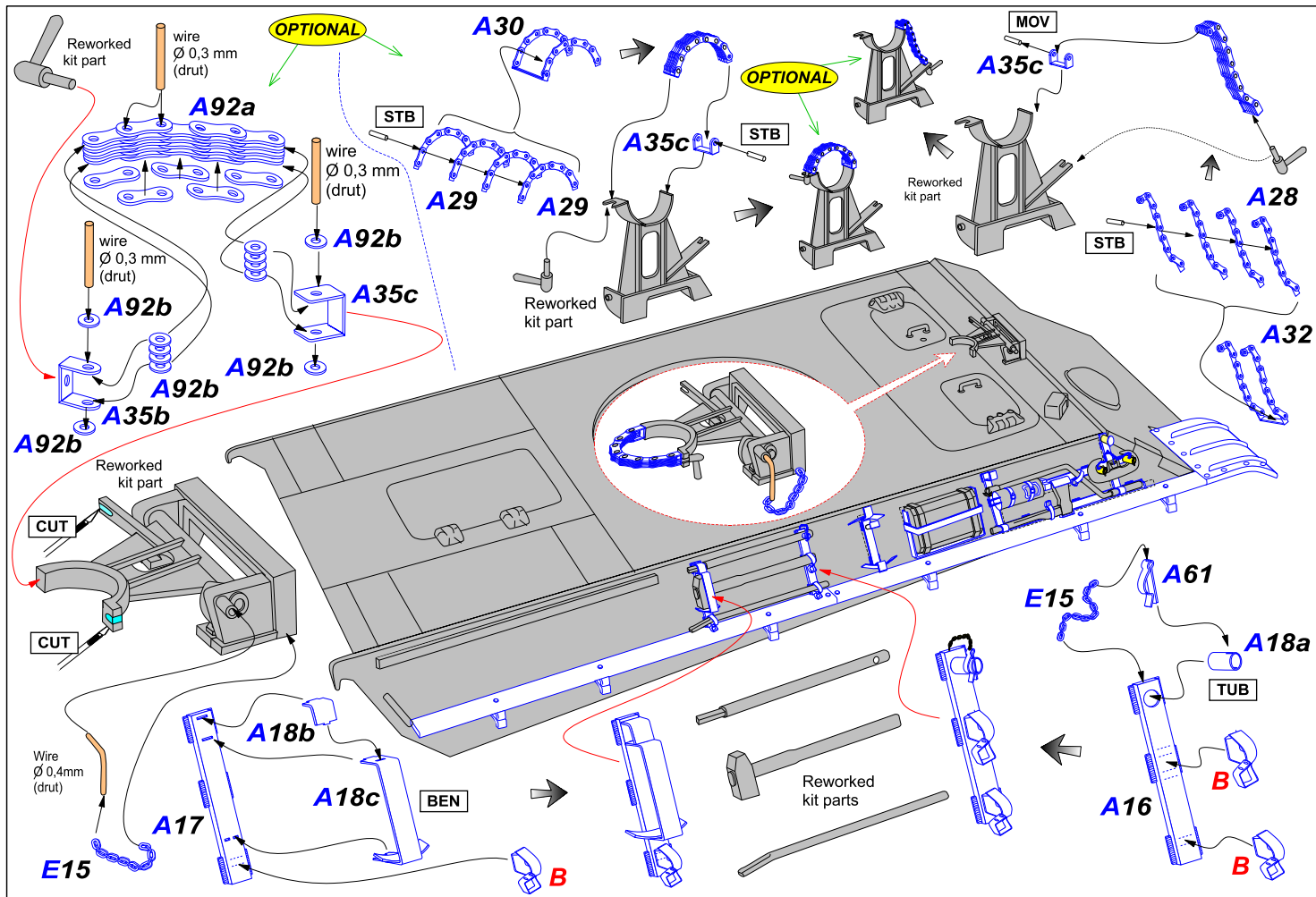

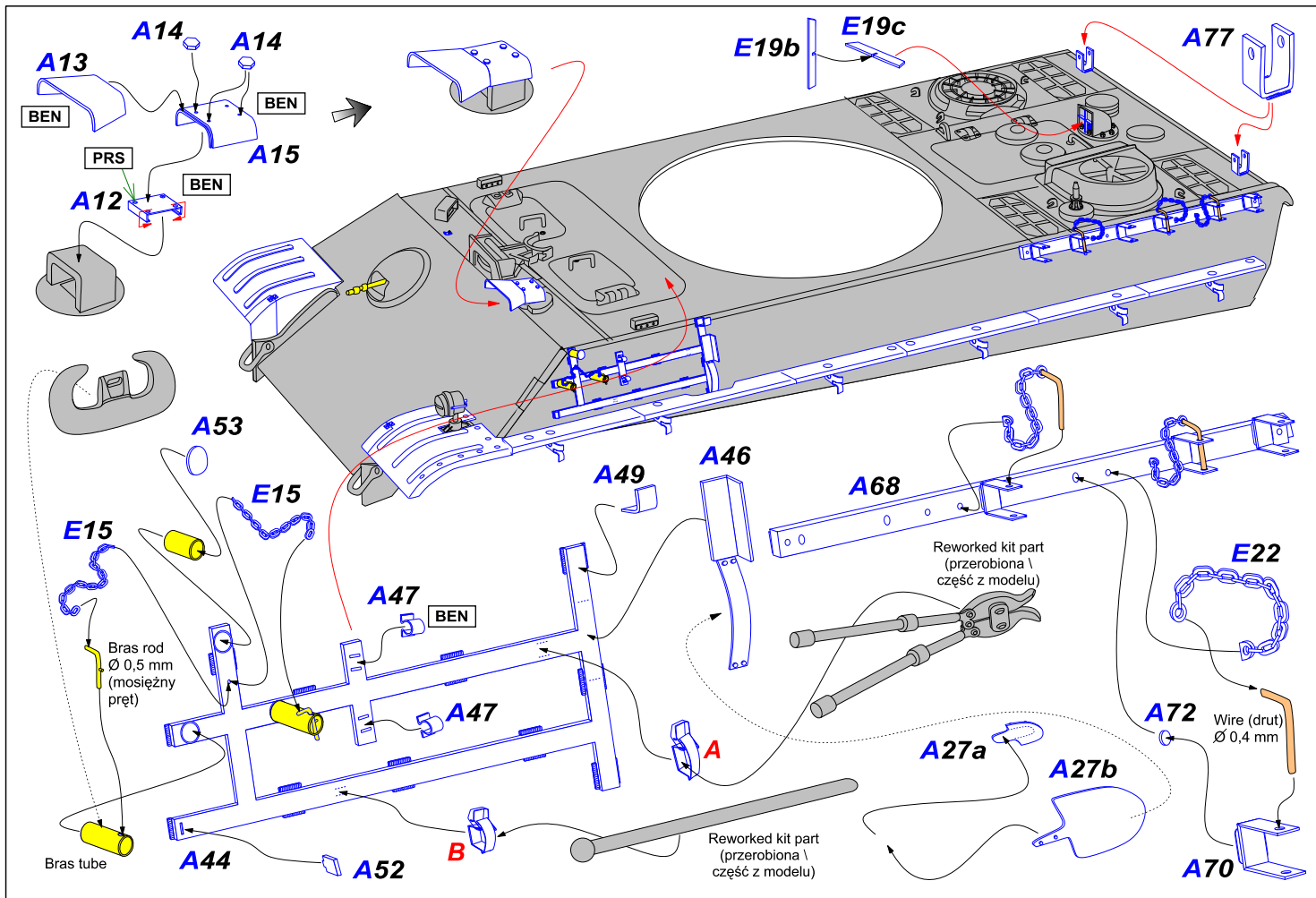

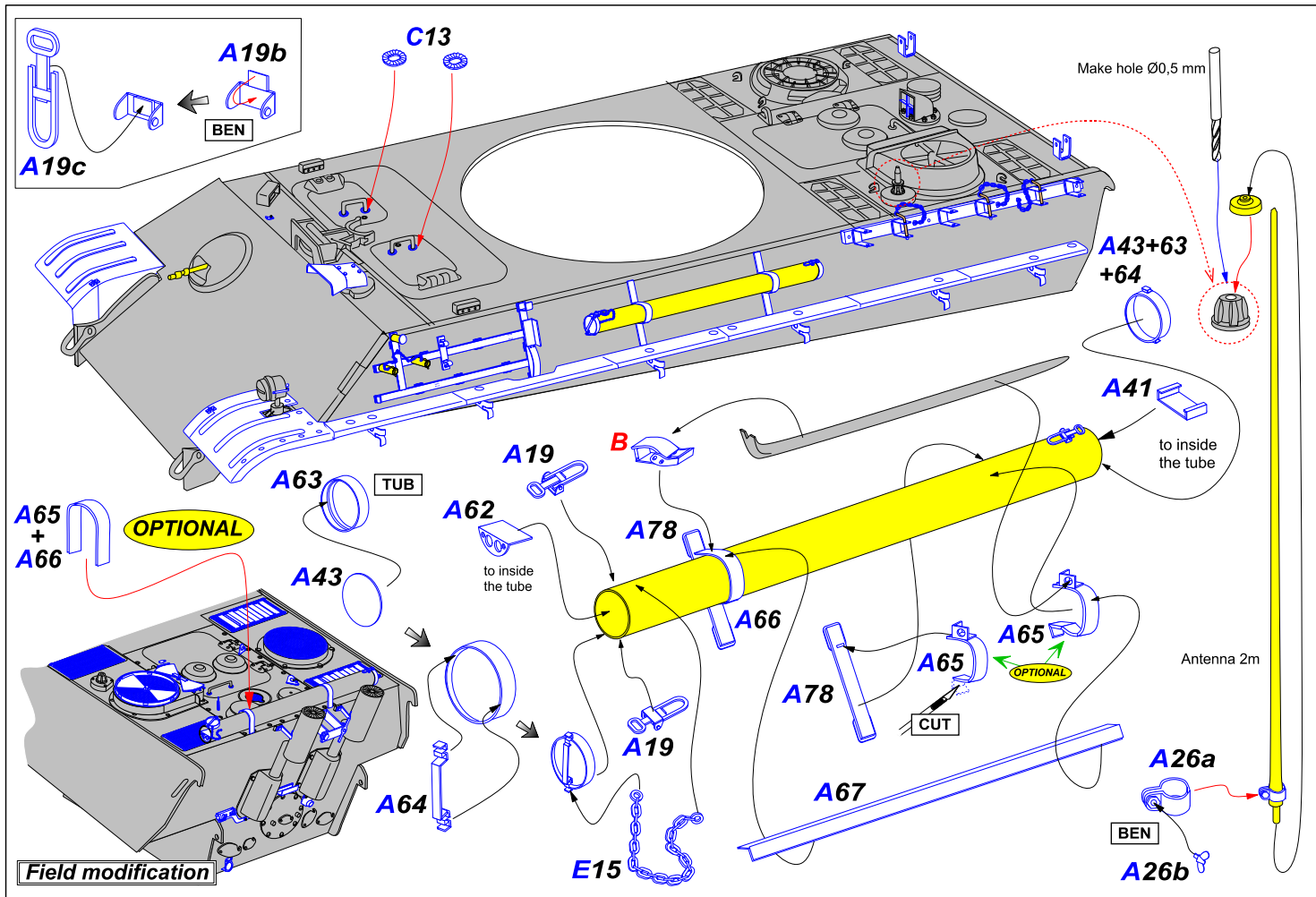



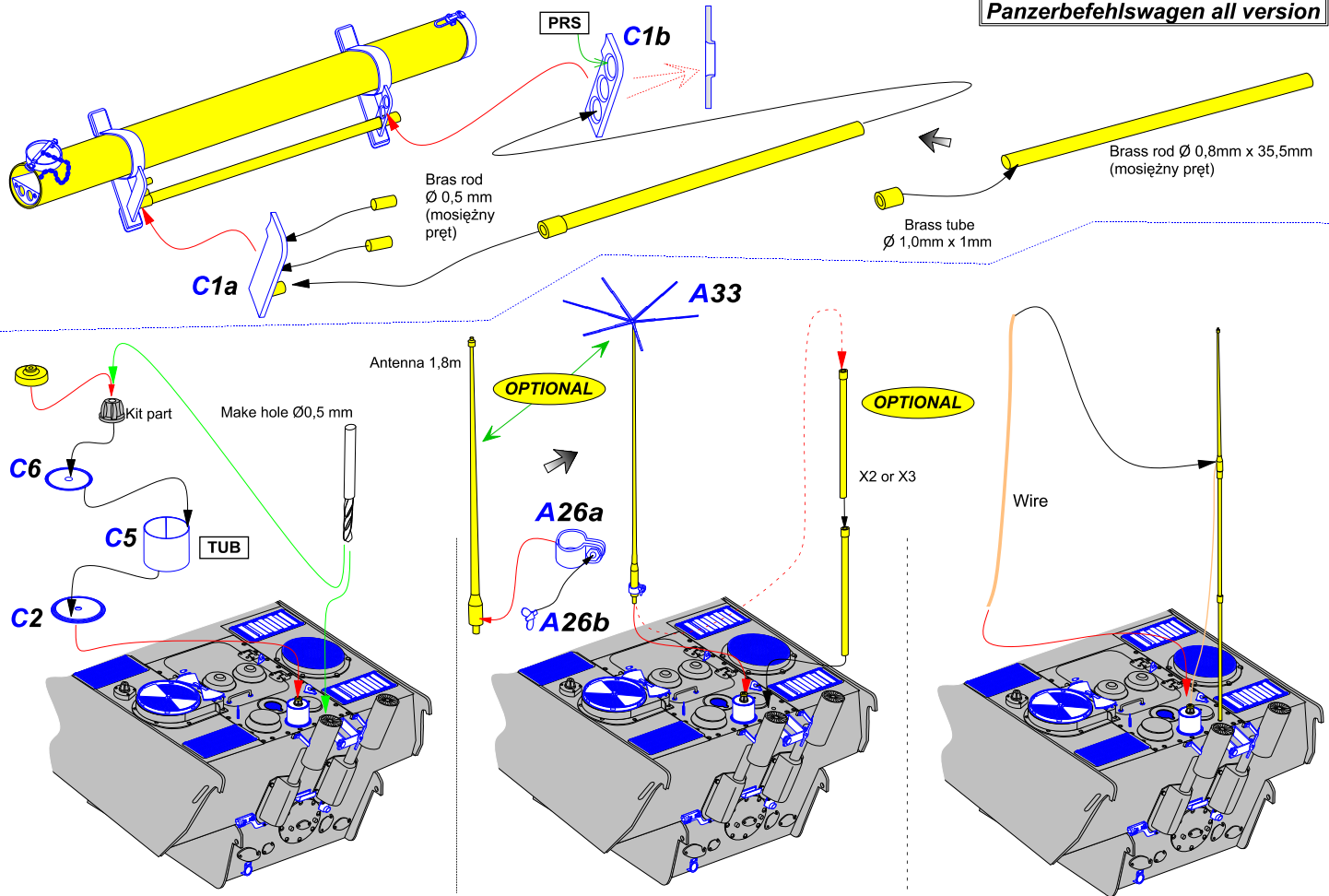

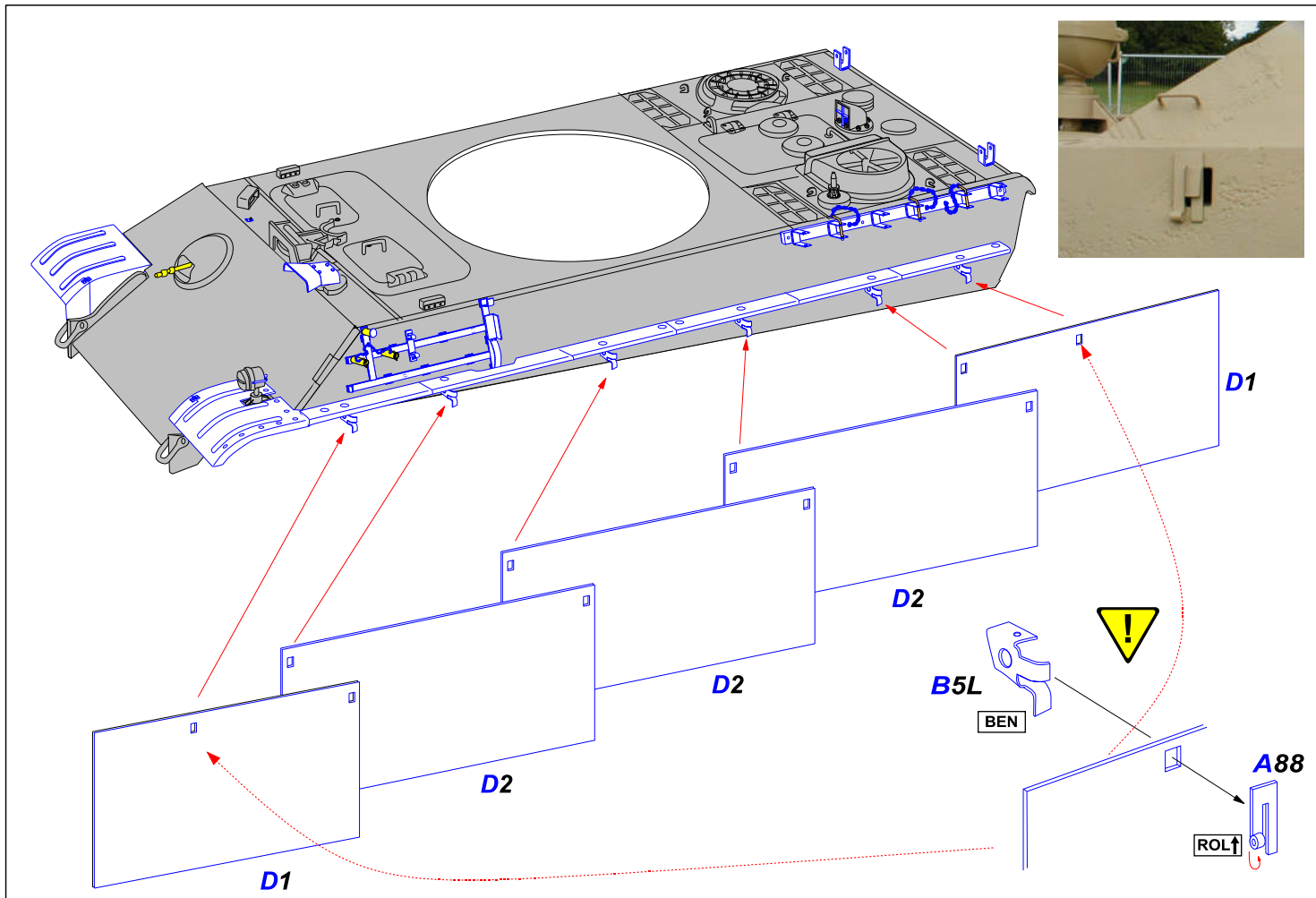

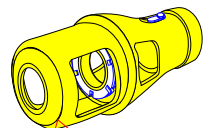
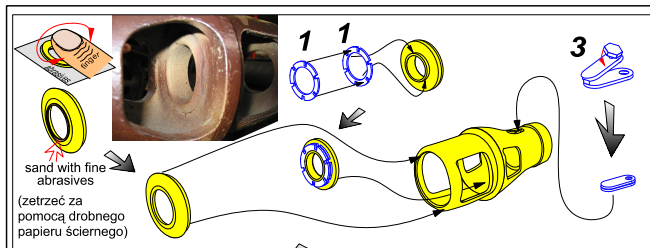

Fill with putty or solder  
then sand with fine  
abrasives

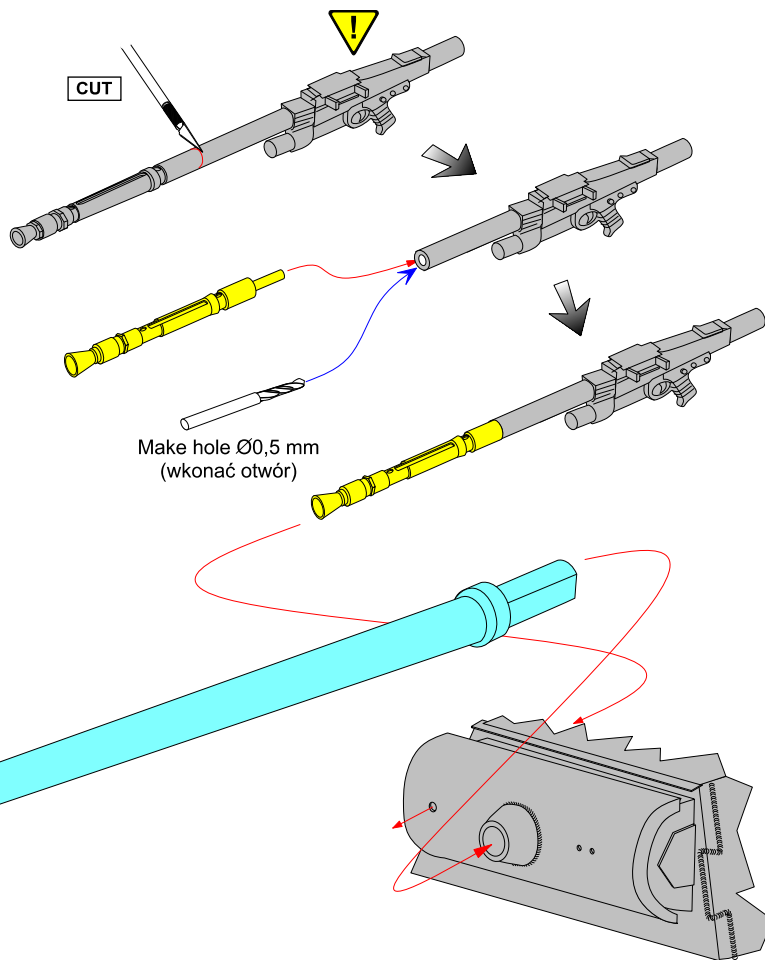
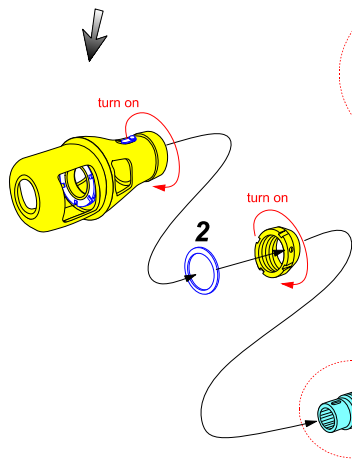

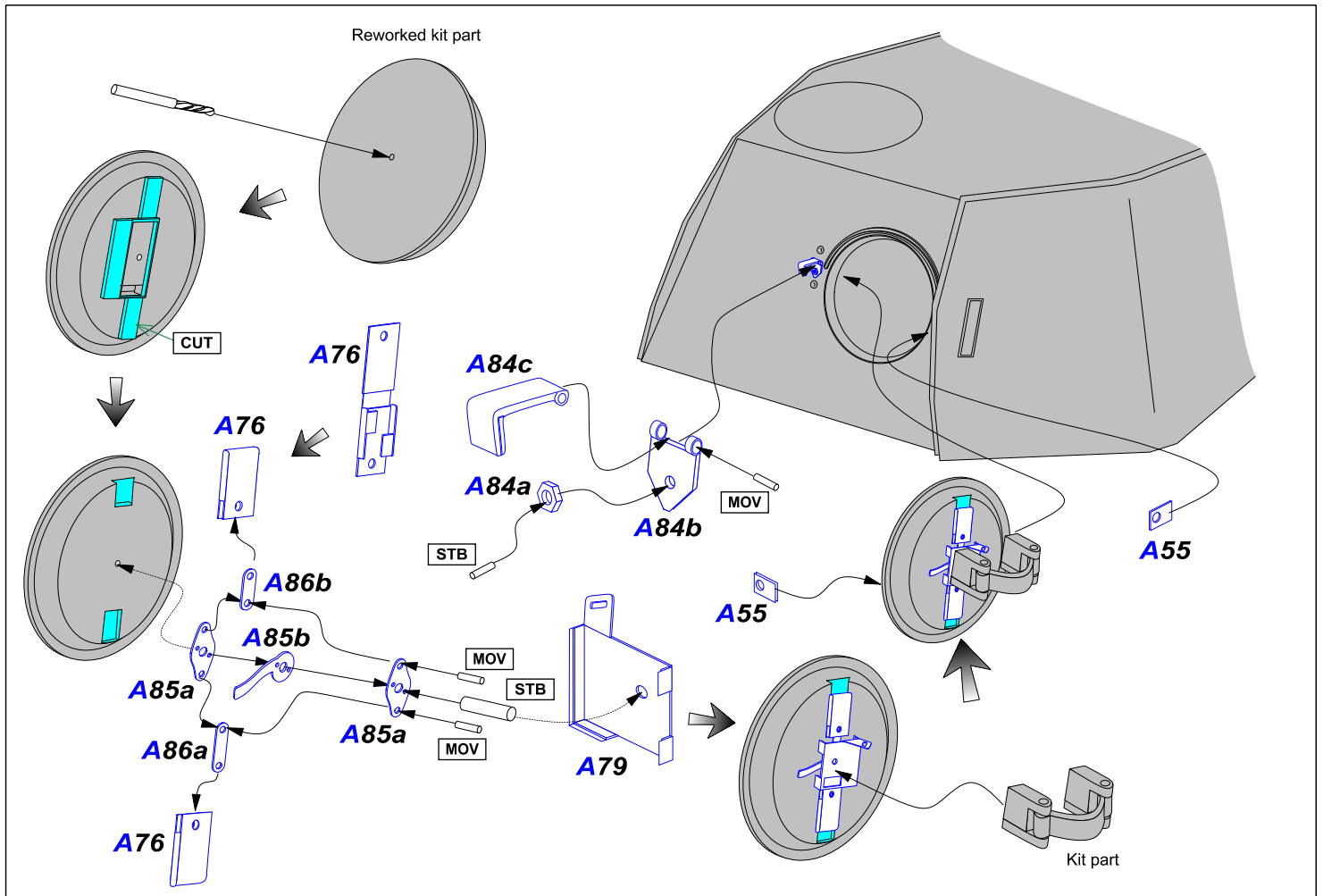

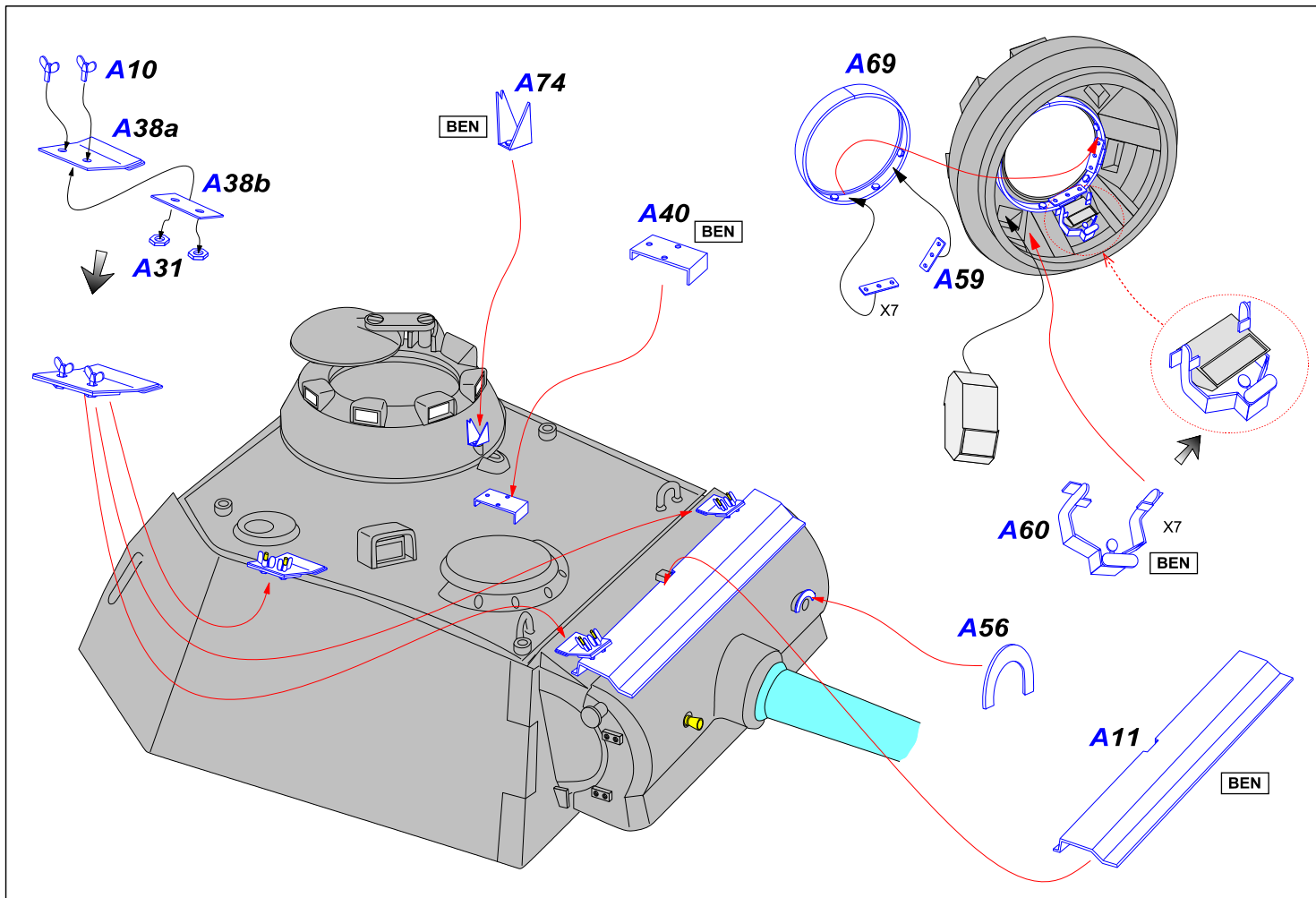

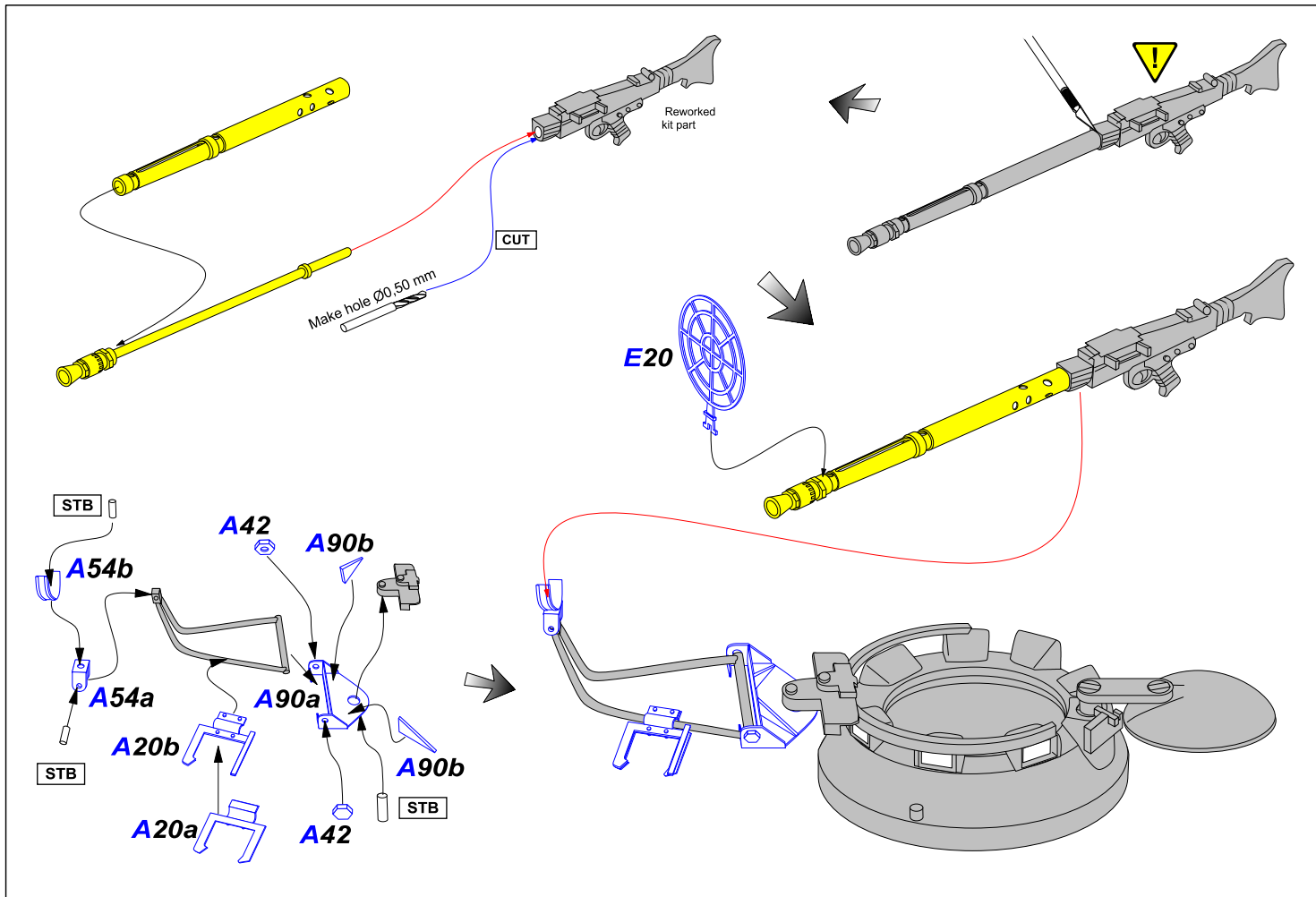

Make hole  $\varnothing 0,5$  mm and then light cavity  $\varnothing 1,1$  mm (wykonać otwór a następnie lekkie wgłębienie)

Use part F3 as stencil and mark holes (Część F3 użyć jako szablon do zaznaczenia otworów)

