

P-35

HCI552 • 1:48 • USAAC Fighter

One of the most famous U.S. fighters of the 1930's! Kit features: • detailed cockpit • landing gear • authentic markings.

L'un des plus fameux chasseurs dans les années 30! Particularités du kit: • l'intérieur détaillé • train d'atterrissage très détaillé • moulage précis • les marques authentiques.

Als eines der bekanntesten Jagdflugzeuge der 30er Jahre! Der Bausatz enthält: • detailliertes Cockpit und Fahrwerk • fein eingravierte Details • authentische Abziehbilder.

Uno dei caccia più famosi degli anni 1930! Caratteristiche del modello: • carlinga dettagliata e carrello di atterraggio • dettagli incisi • decals autentici.

Uno de los más famosos aviones de combate de la década de 1930! Características del kit: • se detallan la cabina del piloto y el aterrizador • marcas auténticas.

 cyanoacrylate glue coller cyanoacrylate Cyanoacrylate kleben incollare cyanoacrylate pegar cyanoacrylate	 cut couper schneiden tagliare cortar	 bend plier sich biegen piegare doblar	 file / sand poncer verspachteln levigare lijar	 weight a laster Gewicht zavorra lastre	 drill or pierce percer bohren forare agujerear	 x2 two deux zwei due dos
 painting instructions mode d'emploi Anleitungen der Farben istruzioni per la verniciatura instrucciones sobre la pintura	 caution! attention! vorsichten! attenzione! atención	 alternative en option Alternativ alternativo alternativa	 cement coller kleben incollare pegar	 paint peindre bemalen verniciare pintar	 decal decalcomania Abziehbild decalcomania calcomanias	 no! no! nein! no! ¡no!



Read This Before You Begin!

- study the assembly drawings
- each plastic part is identified by number
- check the fit of each piece before cementing
- do not use too much cement to join parts
- model may be painted to match box illustration

Lisez Ce Qui Suit Avant De Commencer Le Montage!

- étudier les schémas d'assemblage
- chaque pièce plastique porte un numéro d'identification
- contrôler que chaque pièce soit bien conforme avant de la coller à sa place
- utilisez uniquement une colle spéciale pour polystyrène
- le modèle peut être peint conformément aux illustrations de la boîte

Vor Zusammenbau lesen sie bitte!

- studiere die Bauanleitung
- die Plastikteile sind gekennzeichnet durch ihre Nummern
- vor dem Kleben prüfe ob die Teile zusammenpassen können
- benutze nicht zuviel Klebstoff
- die Bemalung des Modells kann auf dem Becketbild zeigen

1

Cockpit Assembly / Assemblage de L' Interieur

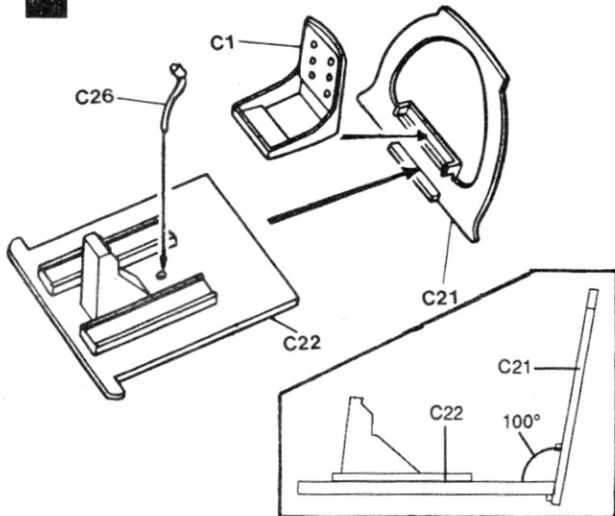

2

Propeller Assembly / Assemblage de Helice

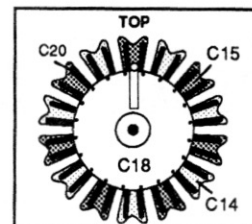
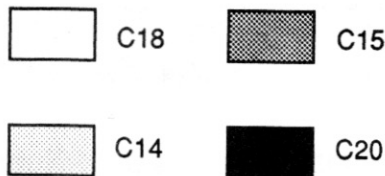
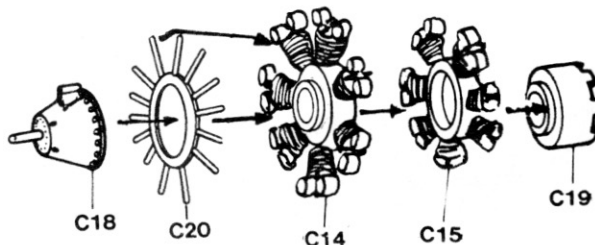

3

Fuselage Assembly / Assemblage du Fuselage

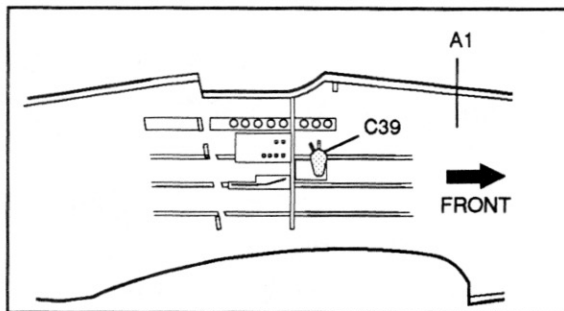
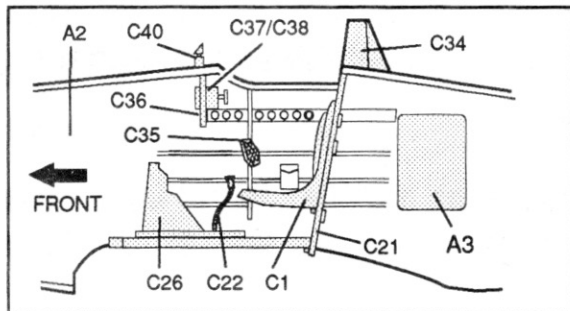

Possible machine gun configurations.

1. 0.30 in./ 7.62mm X2 (C37/38)
2. 0.50 in./12.7 mm X2 (C37/38)
3. 0.30 in./ 7.62mm X1 (C37)
0.50 in./12.7 mm X1 (C38)

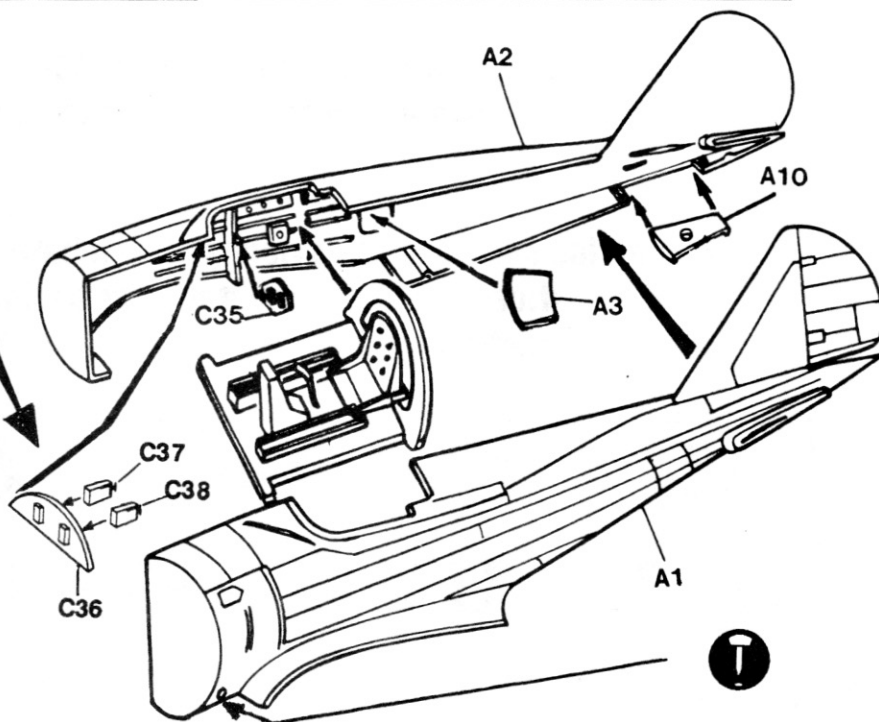
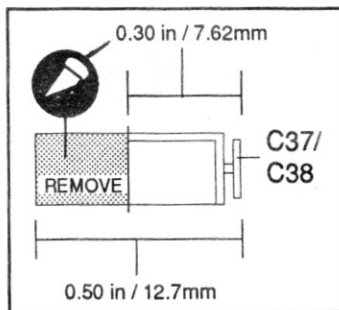

4

Wing Assembly / Assemblage des Ailes

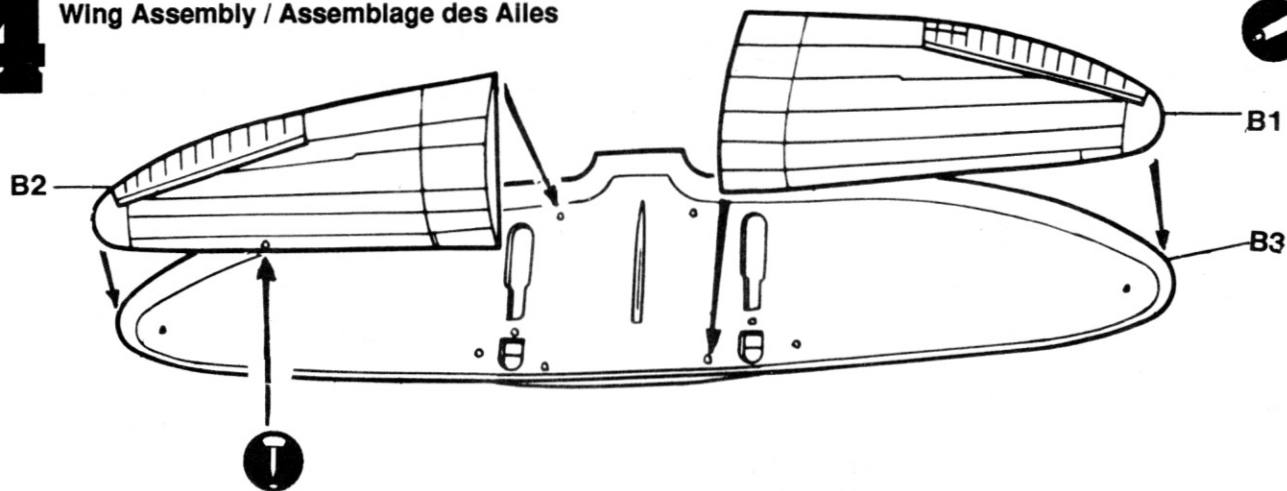

5

Wing, Fuselage & Canopy Assembly / Assemblage Ailes, Fuselage & Partie Verriere

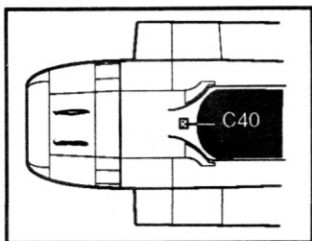
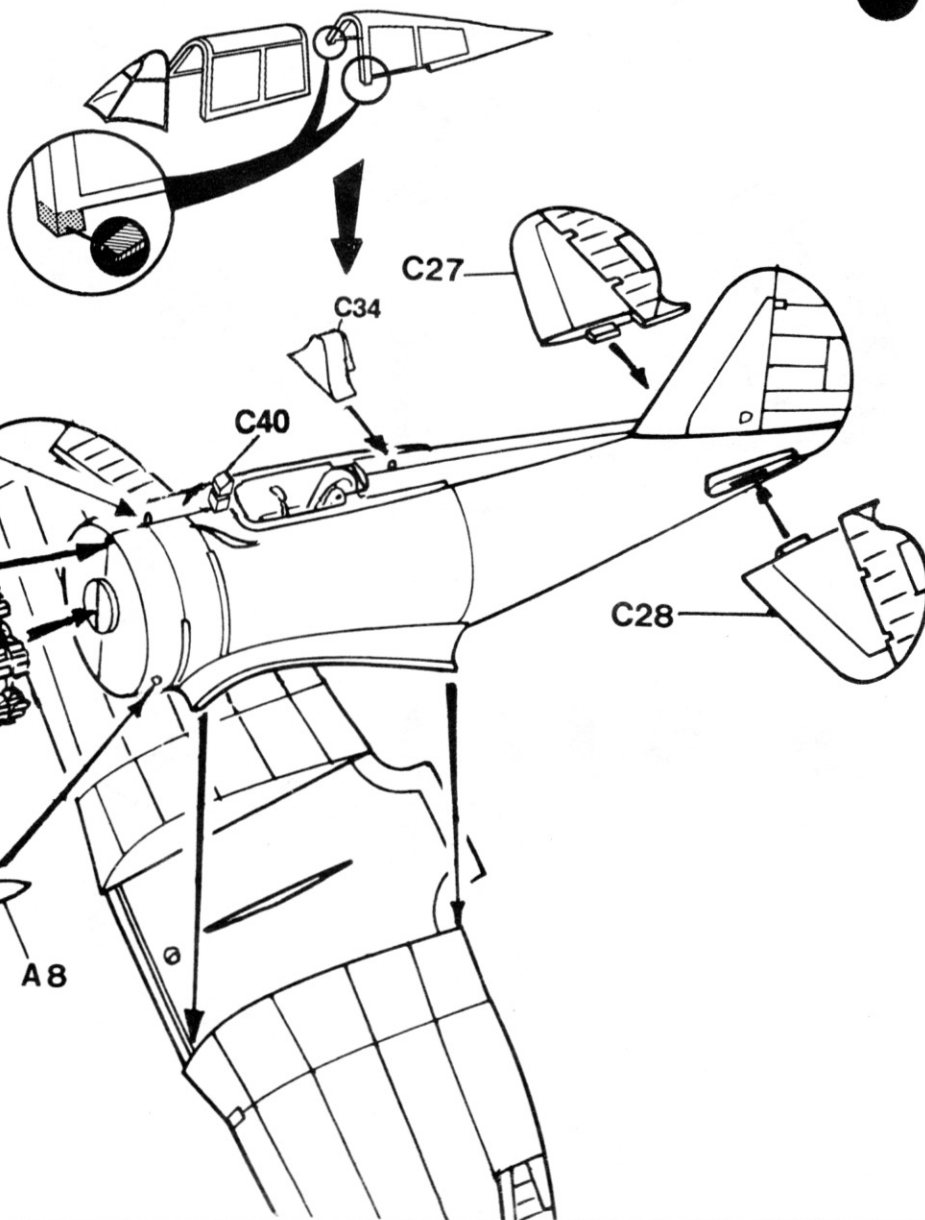
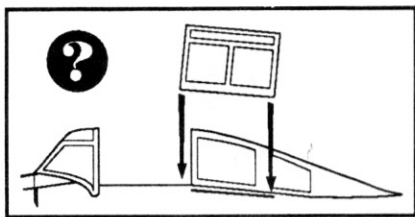

6

Landing Gear Assembly / Train D' Atterrissage



Add Doors After Mounting Legs

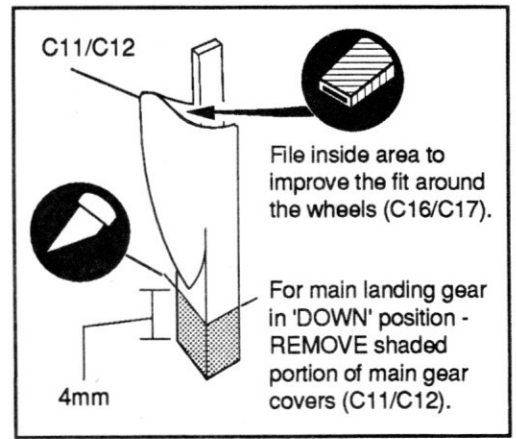
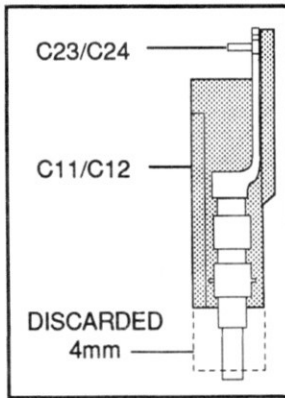
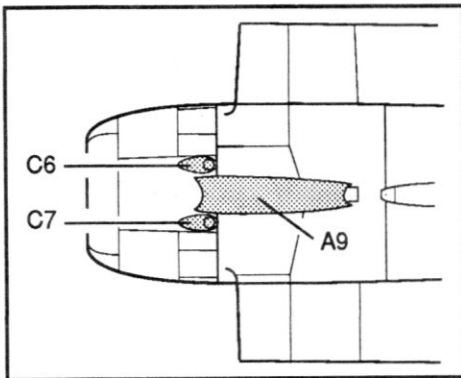
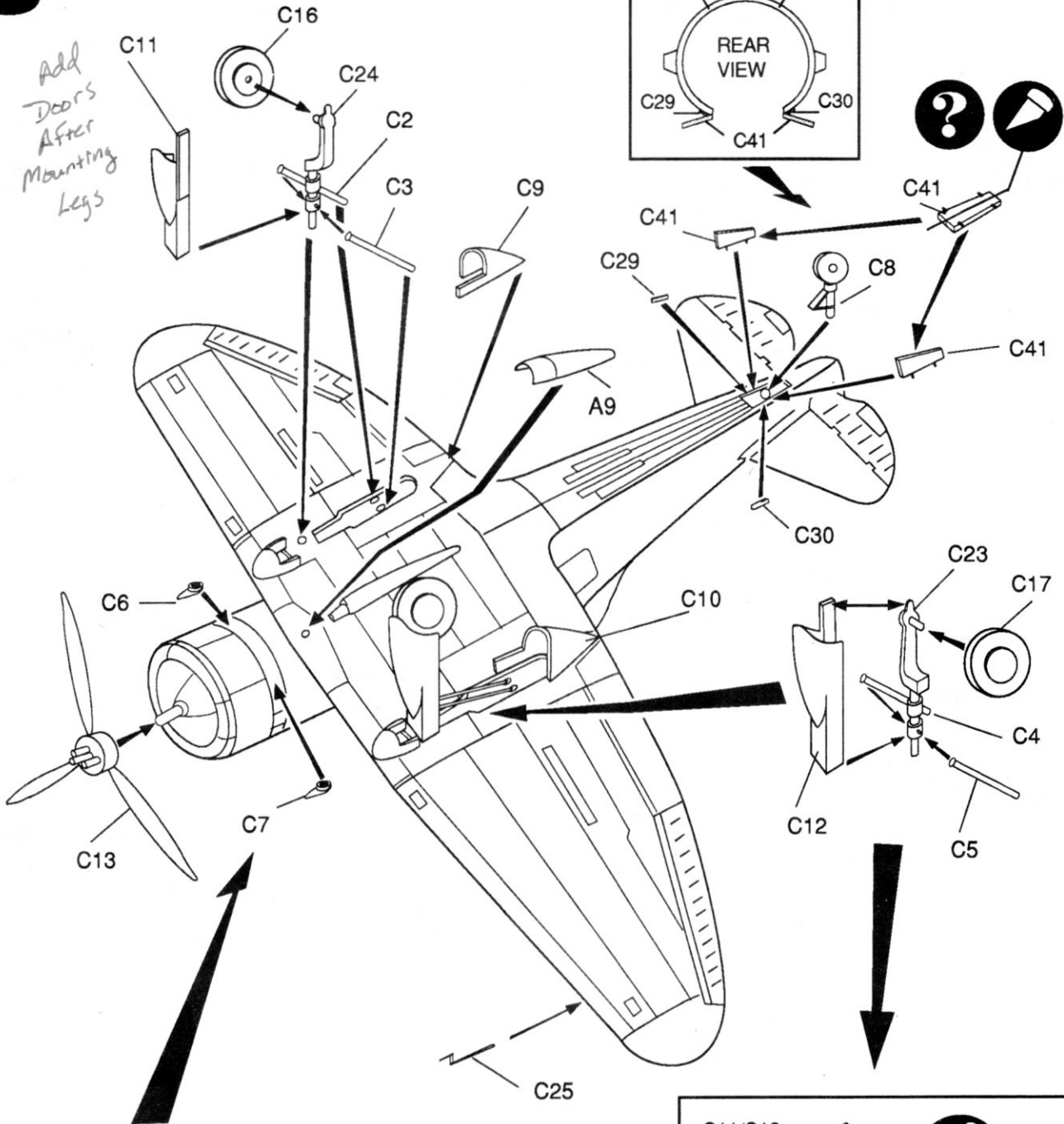
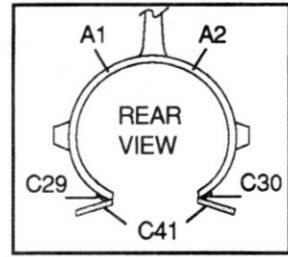

Seversky P-35

Markings • Appliques



paint
peindre
bemalen
verniciare
pintar

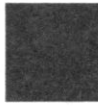

FS37038
black
noir
Schwarz
negro
negro



FS17875
white
blanc
Weiß
bianco
blanco

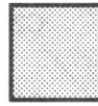

FS?????
aluminium
aluminium
Aluminium
alluminio
aluminio



decal
decalcomania
Abziehbild
decalcomania
calcomanías

USAAC, 17th Pursuit Sqn., 1939

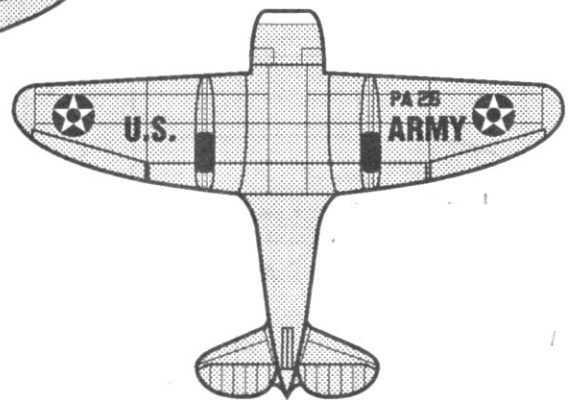
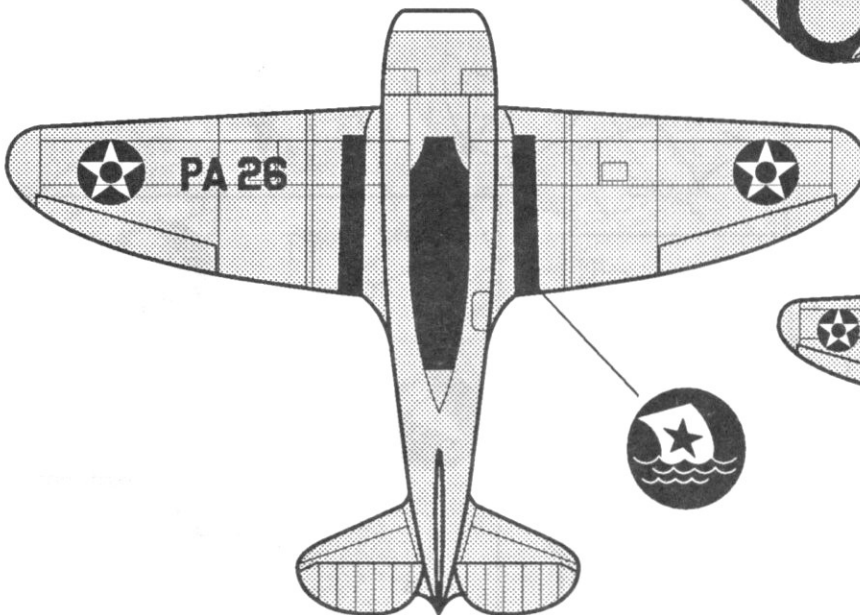
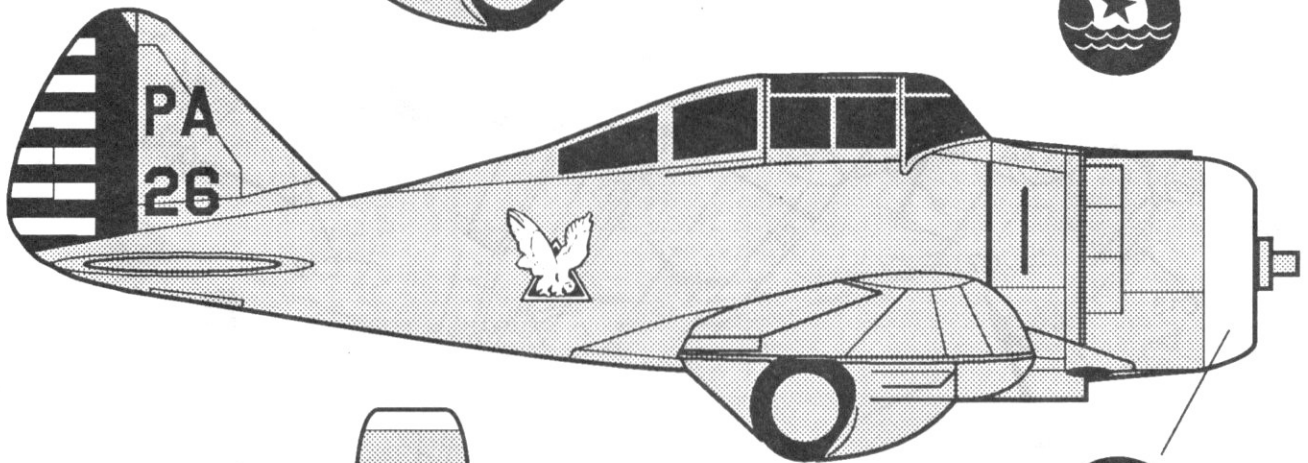
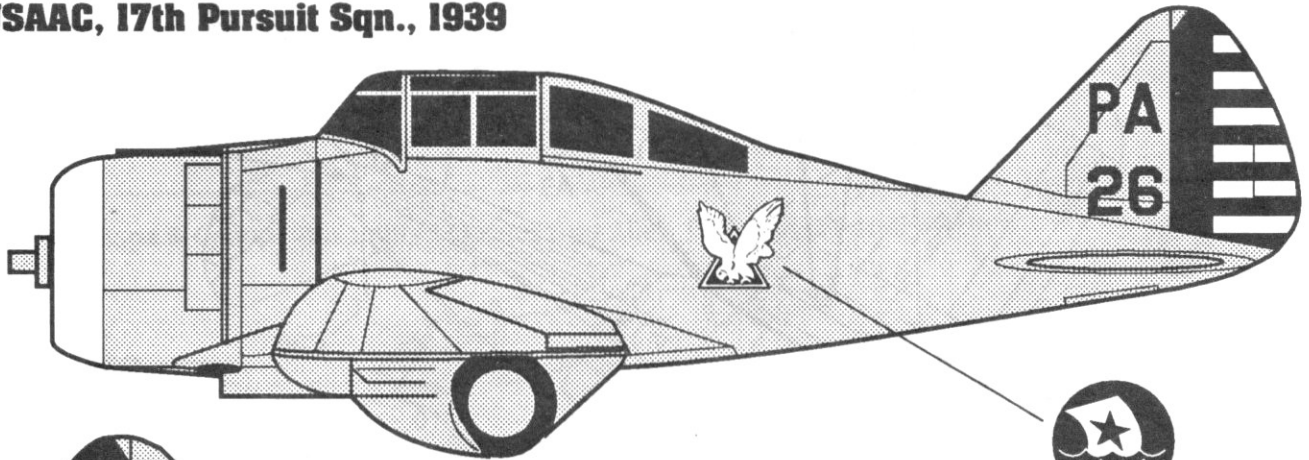

Seversky P-35

Markings • Appliques



paint
peindre
bemalen
verniciare
pintar

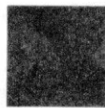

FS37038
black
noir
Schwarz
negro
negro

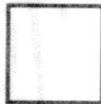

FS17875
white
blanc
Weiß
bianco
blanco

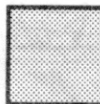

FS?????
aluminium
aluminium
Aluminio
alluminio
aluminio



decal
decalcomania
Abziehbild
decalcomania
calcomanías

USAAC, 94th Pursuit Sqn., 1938

