

**MONOGRAM**

KIT 5820

# BLUE ANGELS' F-18 HORNET

MONOGRAM MODELS, INC. Des Plaines, IL Copyright ©1987. All rights reserved. Made in U.S.A.

5820-0201

1/48 SCALE

MASSTAB 1:48

ESCALA 1/48

SCHAAL 1:48

1/48 ECHELLE

SKALA 1/48

SCALA 1/48

In 1946, the U.S. Navy's crack flight demonstration team, the Blue Angels, was formed. Since then the planes used by the team have been standard versions of contemporary combat types, modified only by the removal of weapons and related equipment, and the addition of smoke generators.

Since their first demonstrations, over forty years ago, the Angels have flown in seven production fighter types. Beginning with the Grumman F6F Hellcat these have included the Navy's first jet combat fighter, the Panther, and the impressive Phantom II. For a short while, the Angels even performed with the unique Vought F7U-1 Cutlass tailless fighter. In 1957, they began using the supersonic Grumman F11F Tiger, and this plane served them well for eleven years, and then they were exchanged for the powerful Phantom IIs.

For longevity, however, the little A-4 Skyhawk holds the record, twelve years of faithful service. But even this little "Hot Rod" has reached the end of its tenure with the team and in 1987, its successor, the sleek McDonnell Douglas F/A-18 Hornet, has donned the distinctive blue and gold uniform of the famous team.

The selection of the Hornet is in keeping with the concept of the Blues. It's the most modern fighter in the Navy's inventory, and the demonstrations are developed around the combat capability of the airplanes. As has been so often stated by the Navy, these are not just dare-devil pilots out for a thrill, but dedicated Naval Airmen demonstrating many of the tactical maneuvers used by the Navy during actual combat missions.



OPTIONAL PARTS  
BAUTEILE NACH WAHL  
PREZAS OPCIONALES  
KEUZE-ONDERDELEN  
PIECES EN OPTION  
VALTRIN DESAR  
PARTI FACOLTATIVE



REMOVE AND THROW AWAY  
ENTFERNEN (ABFALL)  
QUITE Y TIRE  
VERWILDEREN EN WEGGOEDEN  
A RETIRER ET JETER  
AVLAGSNAS OCH MAKULLERAS  
RIMOVATI ED ELIMINA



DECAL (DIP IN WATER)  
ABZIEHBLD  
DECALCOMANIA (MOJE DOU AGUA)  
TRANSFERS (IN WATER DOPEN)  
DECALCOMANIE (A PLONGER DANS L'EAU)  
DECAL (DOPPAS - VATTEN)  
DECALCOMANIA (IMMERGI IN ACQUA)



REPEAT SEVERAL TIMES  
ARBEITSGANG MEHRMALS WIEDERHOLEN  
REPETA VARIAS VECES  
ENIGE KEREN MEERHALEN  
A REPETER PLUSSIGURS FOIS  
ARBEITSMOMENT SOM UPPREPAS  
RIPETI DIVERSE VOLTE

If you have any problems building this model, call our modeling tips hotline at: **(800) 833-3570**

Every effort has been made to create and manufacture a model kit that is the finest available. If a part may be missing, please write to:

**Monogram Models, Incorporated**  
Consumer Service Department  
395 North Third Avenue  
Des Plaines, Illinois 60016

Be sure to include the kit number, part number, description, and your return address.

**READ THIS BEFORE YOU BEGIN**

- Study the assembly drawings.
- Each plastic part is identified by a number.
- Check the fit of each piece before cementing in place.
- Do not use too much cement to join parts.
- Use only cement for polystyrene plastic.
- Model may be painted to match photos on box.
- Allow paint to dry thoroughly before handling parts.
- Scrape paint from areas to be cemented.
- For better paint and decal adhesion, wash the plastic parts in a mild detergent solution. Rinse and let air dry.

**ALLGEMEINE HINWEISE**

- Die Anordnung der Bauteile ist aus den Zeichnungen der Anleitung ersichtlich.
- Jedes Plastikteil ist durch eine Nummer gekennzeichnet.
- Die Teile vor dem Verkleben ungeleimt zusammenhalten, um ihren Passsitz zu prüfen.
- Klebstoff nicht zu dick auftragen.
- Nur Modellbaukleber für Polystyrol verwenden.
- Man kann das Modell nach den fotos auf der schachtel anstreichen.
- Bemalte Teile vor der Weiterverwendung gut trocknen lassen.
- Die Farbe muss von allen späteren Klebestellen abgeschabt werden.
- Damit die Farbe und die Abziehbilder besser kleben, sind die Plastikteile in einer milden Seifenlauge zu waschen. Dann abspülen und an der Luft trocknen lassen.

**LEA ESTO ANTES DE EMPEZAR**

- Estudie los dibujos de ensamblaje.
- Cada pieza de plástico se identifica por un número.
- Verifique que cada pieza encaje bien antes de pegar en posición.
- No use demasiado pegamento para unir las piezas.
- Use únicamente pegamento para plástico de poliestirina.
- El modelo puede pintarse de acuerdo con las fotografías de la caja.
- Permita que se seque la pintura completamente antes de tocar las piezas.
- Raspe la pintura de las superficies que serán pegadas.
- Para una mejor fijación de la pintura y de las calcomanías, lávense las piezas plásticas en una solución de detergente suave. Enjuáguese y déjense secar al aire.

**LEES DIT ALVORENS TE BEGINNEN**

- Bestudeer de bouwtekening.
- Elk plastic onderdeel is genummerd.
- Controleer de passing van elk deel vóór het lijmen.
- Gebruik niet te veel lijm.
- Alléén lijm voor polystyreen plastic gebruiken.

- Men kan model verven zoals aangeduid op de doos.
- Laat de verf van de te verwerken delen steeds goed drogen.
- Verwijder de verf van te lijmen oppervlakken.
- Zodat de verf en etiketten beter zullen plakken, was de plastieke delen in een milde seep oplossing. Spoel en laat in de openlucht opdrogen.

**LISEZ CE QUI SUIT AVANT DE COMMENCER LE MONTAGE**

- Etudier les schémas d'assemblage.
- Chaque pièce plastique porte un numéro d'identification.
- Contrôler que chaque pièce soit bien conforme avant de la coller à sa place.
- N'utilisez pas trop de colle pour réunir les pièces.
- Utilisez uniquement une colle spéciale pour polystyrène.
- Le modele peut être peint conformément aux photos sur la boîte.
- Laissez sécher la peinture complètement, avant de manipuler les pièces.
- Grattez la peinture sur les surfaces devant être collées.
- Pour assurer la meilleure adhésion possible de la peinture et des décalcomanies, lavez les pièces de plastique avec une légère solution savonneuse. Rincez et laissez sécher à l'air.

**LAS DET HAR INNAN DU BORJAR BYGGA**

- Studera monteringskisserna.
- Alla plastdelar har identifikationsnummer.
- Kolla noga att delarna passar före limningen.
- Stryk inte för mycket lim på delarna.
- Använd endast lim för polystyren-plast.
- Modellen kan målas enligt fotona på kartongen.
- Låt färgen torka ordentligt före limningen.
- Skrapa bort färgen på de ytor som ska limmas.
- För bättre vidhäftning av färg och dekalmarken rengör plastdelarna i en mild tvättmedelslösning. Skölj och låt lufttorka.

**DA LEGGERE PRIMA DI INIZIARE**

- Studia le illustrazioni.
- Ogni pezzo è identificato da un numero.
- Controlla l'incastro di ogni pezzo prima di incollarlo.
- Non usare troppa colla per unire i pezzi.
- Adopera solamente colla per materie plastiche.
- Il modello si può dipingere seguendo le fotografie sulla scatola.
- Aspetta che la vernice sia completamente asciutta prima di maneggiare le parti.
- Asporta la vernice dai punti dove applicherai la colla.
- Per una migliore aderenza di vernice e decalcomanie, lavare le parti in plastica in soluzione detergente non abrasiva. Risciacquare e lasciar asciugare all'aria.

<b>A</b>	FLAT BLACK	SCHWARZ	NEGRO	ZWART	NOIR	SVART	NERO
<b>B</b>	DARK GREEN	DUNKELGRÜN	VERDE OSCURO	DONKERGRÖEN	VERT FONCE	MÖRKGRÖN	VERDE SCURO
<b>C</b>	FRENCH BLUE	BLAU	AZUL	BLAUW	BLEU	BLÅ	AZZURRO
<b>D</b>	BRIGHT RED	ROT	ROJO	ROOD	ROUGE	RÖD	ROSSO
<b>E</b>	GUNMETAL	METALLIC	METALICO	METALLIEK	METALLIC	METALLGLANS	METALLICO
<b>F</b>	OLIVE DRAB	OLIVGRÜN	ACITUNADO	OLIJFGRÖEN	VERT OLIVE	OLIVBRUN	VERDE OLIVA SCURO
<b>G</b>	DARK GULL GRAY	GRAU	GRIS	GRUJS	GRIS	GRÅ	GRIGIO
<b>H</b>	YELLOW	GELB	AMARILLO	GEL	JAUNE	GUL	GIALLO
<b>J</b>	SATIN WHITE	WEISS	BLANCO	WIT	BLANC	VIT	BIANCO
<b>K</b>	DARK TAN	HELLBRAUN	MARRON CLARO	LICHT BRUIN	MARRON CLAIR	LJUSBRUN	MARRONE CHIARO

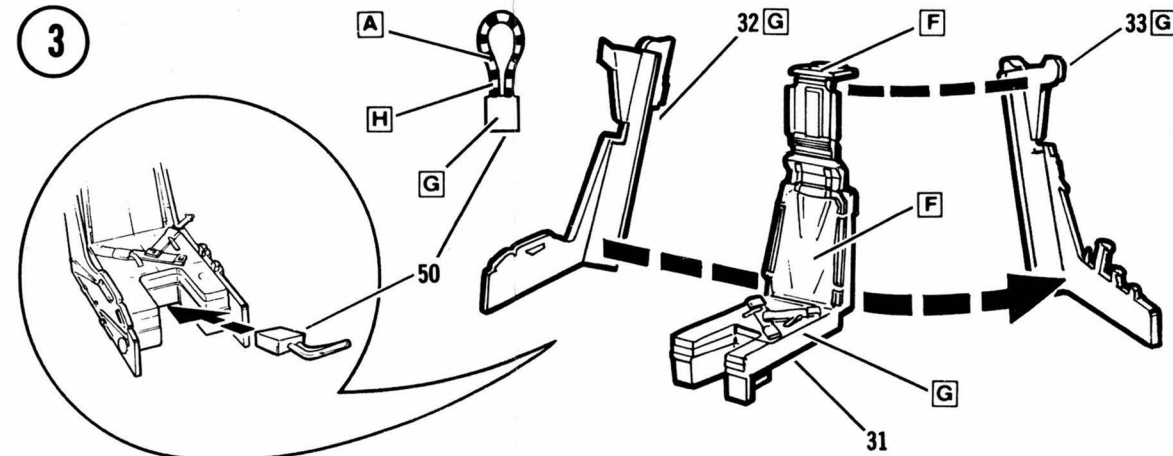
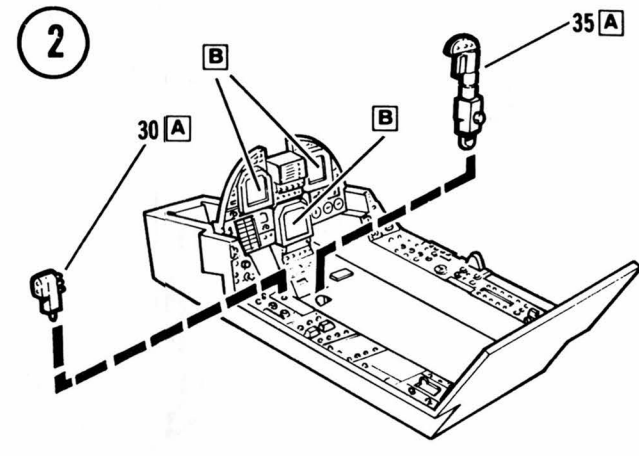
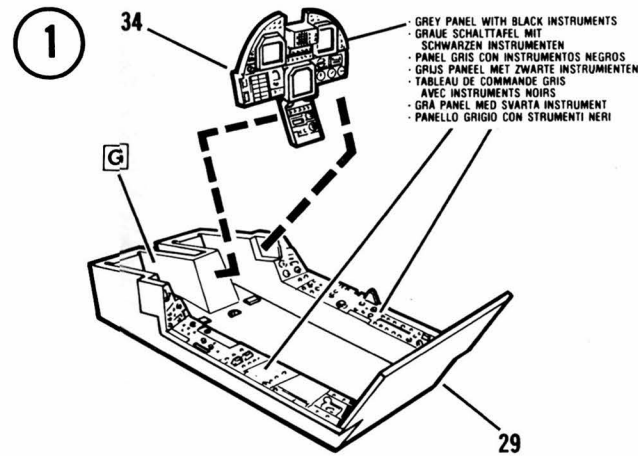

CUT OUT STRAP FOR SEAT ASSEMBLY  
 DER RIEMEN IST ZUM ZUSAMMENBAU DES SITZES AUSZUSCHNEIDEN  
 RECORTESE EL CINTURON PARA EL ARMADO DEL ASIENTO  
 KNIP UIT RIEM VOOR MONTAGE VAN ZITPLAATS  
 DECOUPER LA CEINTURE POUR LE MONTAGE DU SIEGE  
 KLIPP UT SÄKERHETSÅLTET FÖR SITSMONTERINGEN  
 RITAGLIARE CINTURA PER MONTAGGIO SEDILE

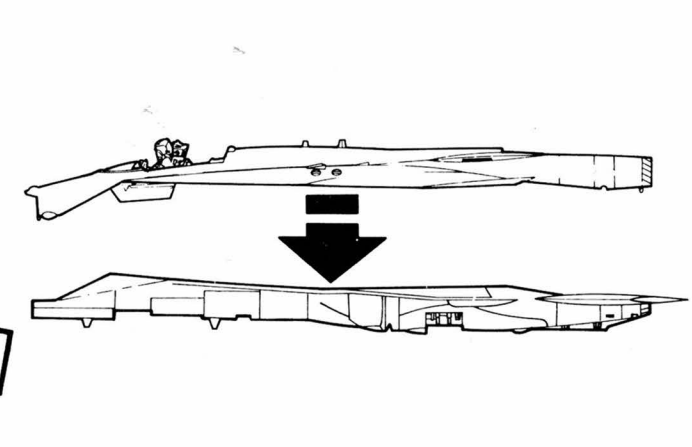
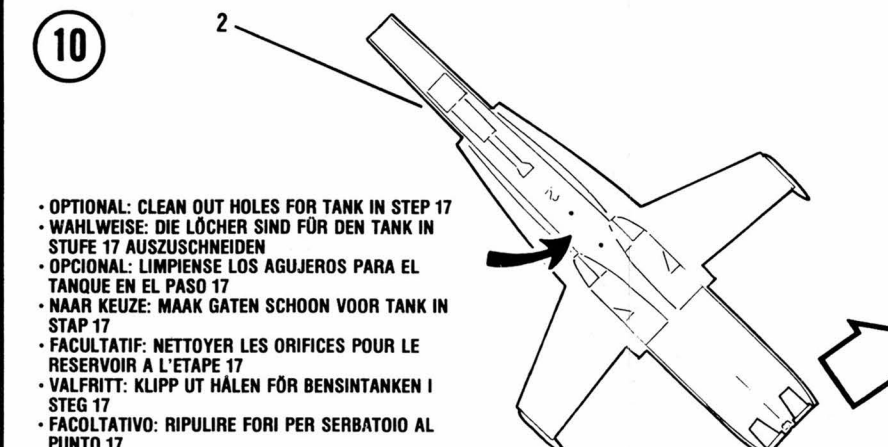
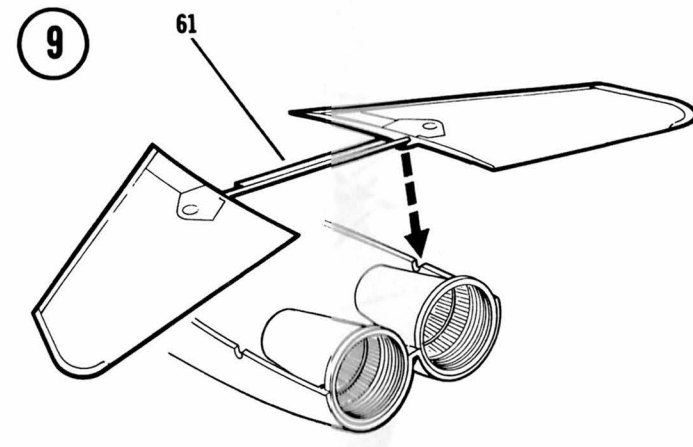
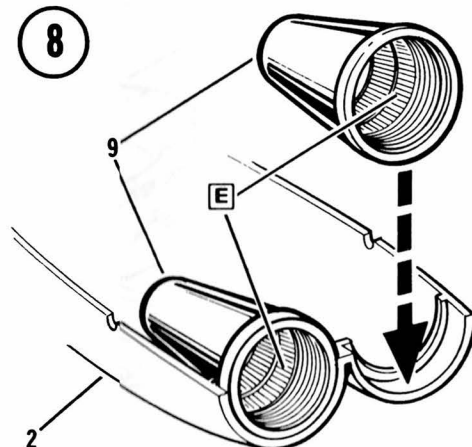
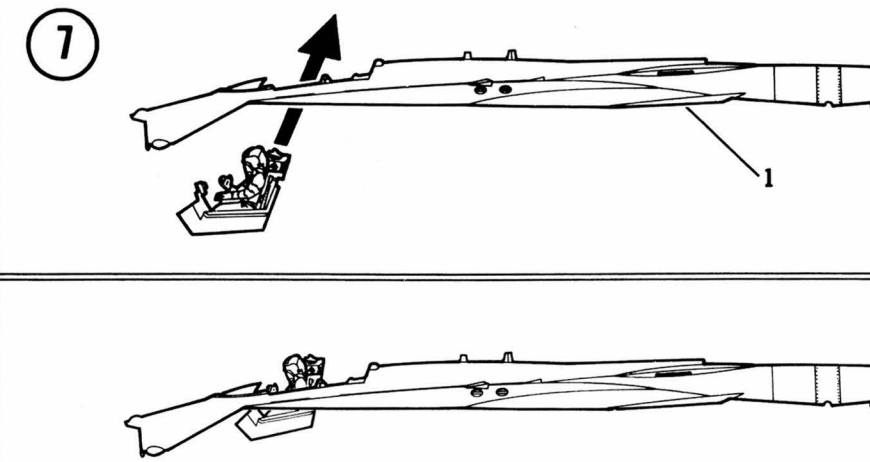
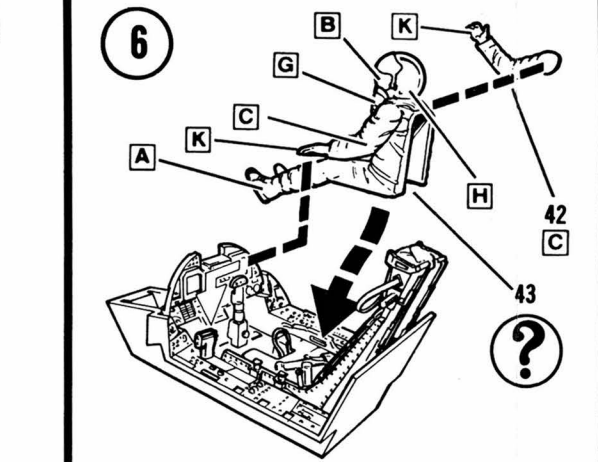
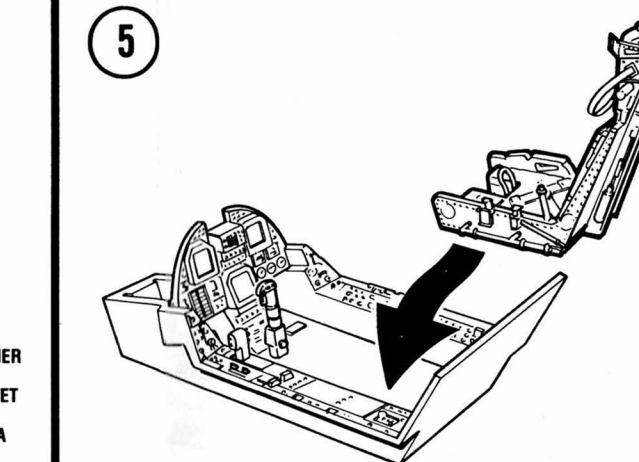
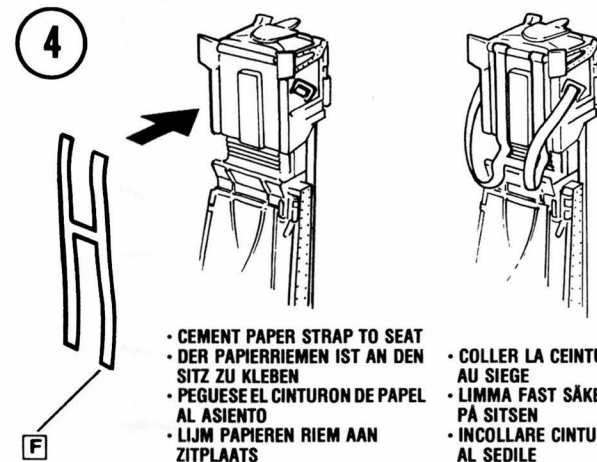

OPTIONAL: CLEAN OUT HOLES FOR TANK IN STEP 17  
 WAHLWEISE: DIE LÖCHER SIND FÜR DEN TANK IN STUFE 17 AUSZUSCHNEIDEN  
 OPCIONAL: LIMPIENSE LOS AGUJEROS PARA EL TANQUE EN EL PASO 17  
 NAAR KEUZE: MAAK GATEN SCHOON VOOR TANK IN STAP 17  
 FACULTATIF: NETTOYER LES ORIFICES POUR LE RESERVOIR A L'ETAPE 17  
 VALFRITT: KLIPP UT HÅLEN FÖR BENSINTANKEN I STEG 17  
 FACOLTATIVO: RIPULIRE FORI PER SERBATOIO AL PUNTO 17

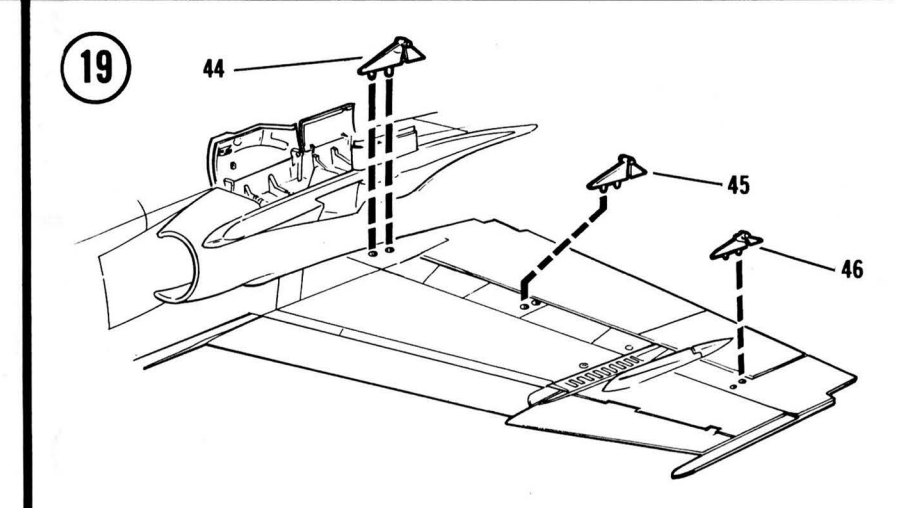
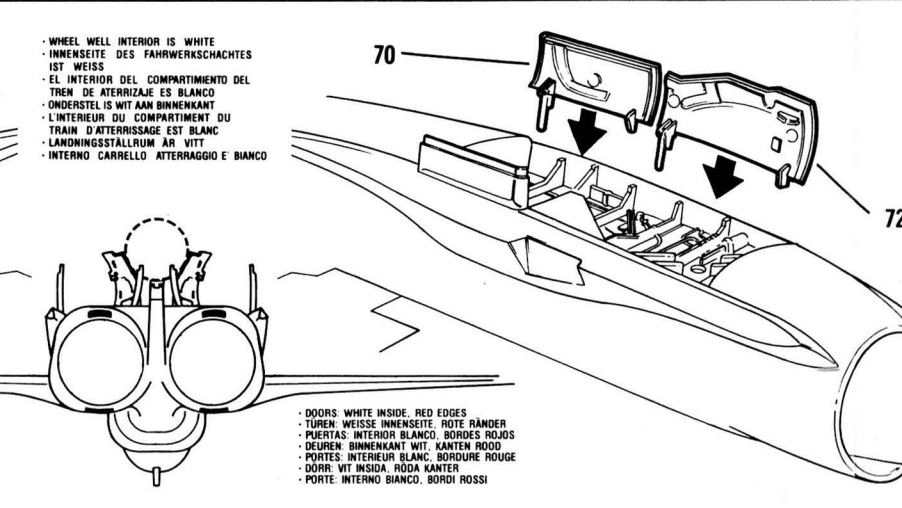
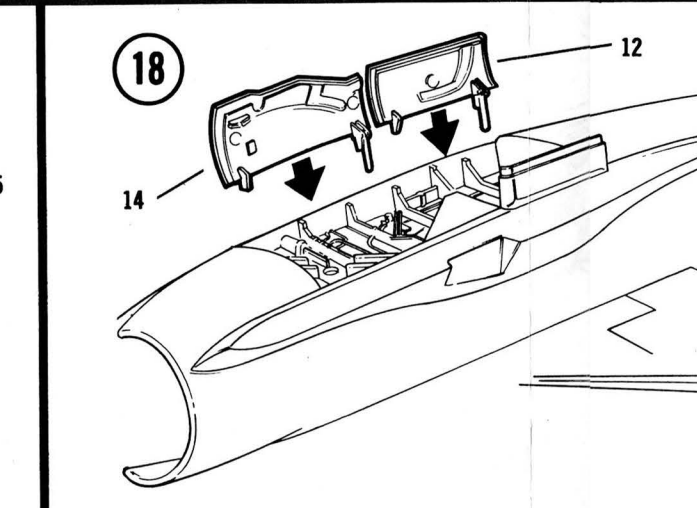
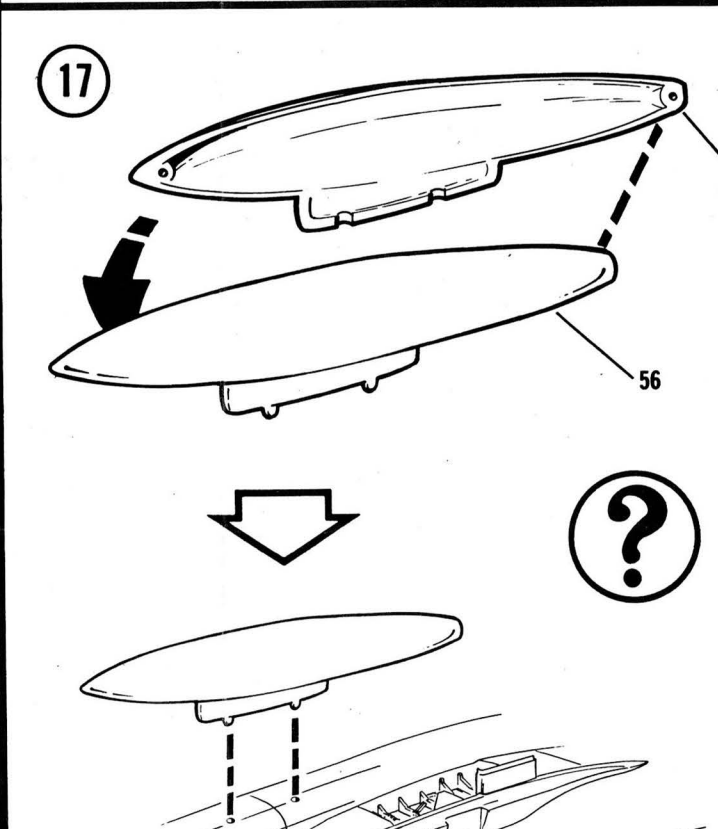
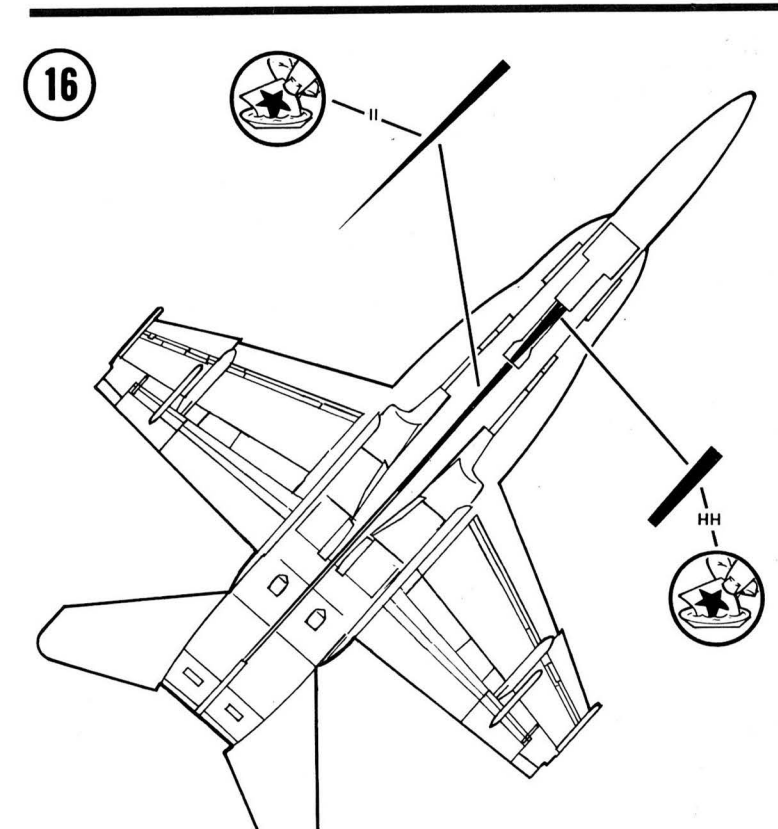
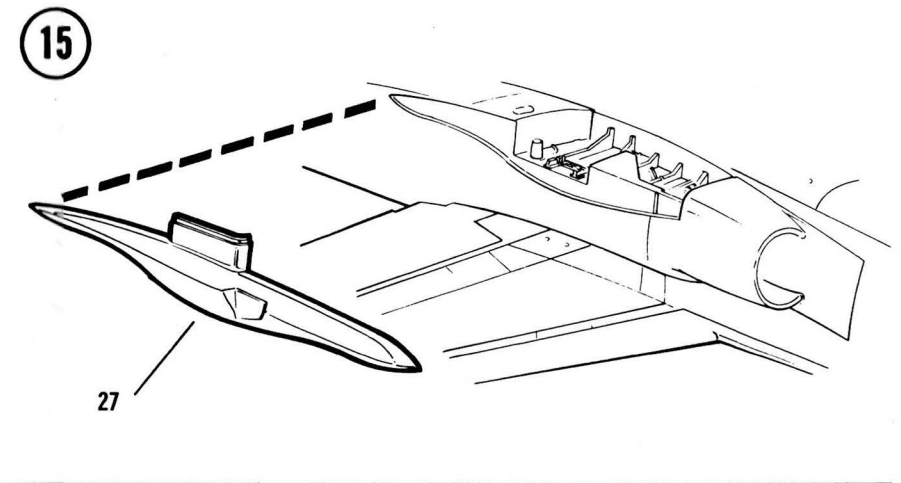
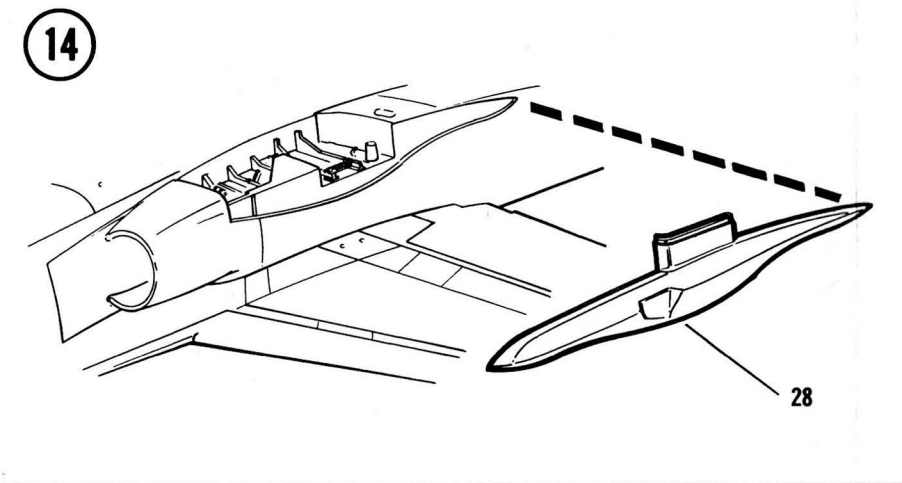
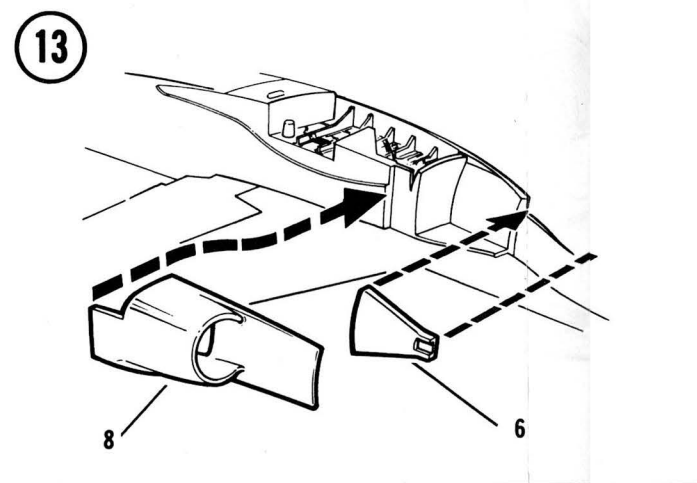
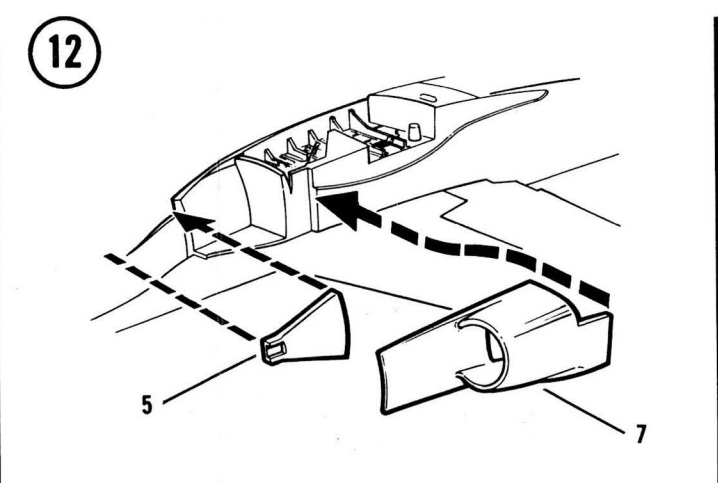
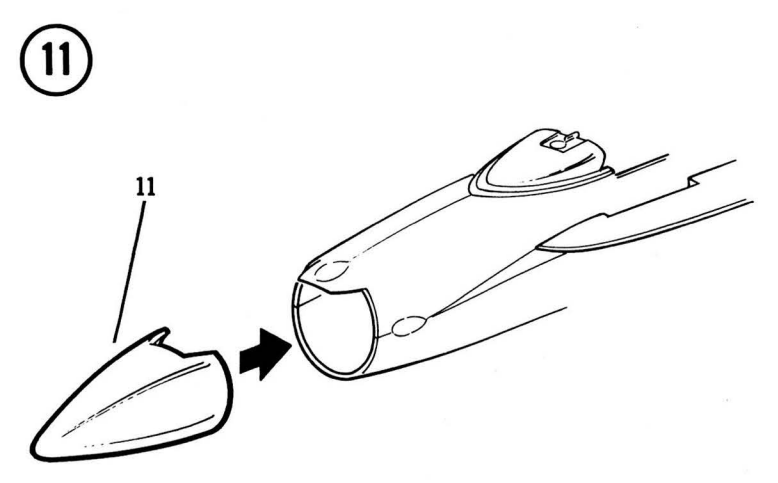

• NOW ADD DECAL IF YOU DO NOT PAINT MODEL  
 • FALLS DAS MODELL NICHT ANGESTRICHEN WIRD, SOLL DAS ABZIEHBILD JETZT ANGEBRACHT WERDEN  
 • AHORA APLIQUESE LA CALCOMANIA SI NO SE PINTA EL MODELO  
 • DOE NU HET ETIKET EROP IN GEVAL U HET MODEL NIET VERFT  
 • MAINTENANT APPoser LA DECALCOMANIE SI VOUS NE PEIGNEZ PAS LA MAQUETTE  
 • SÄTT PÅ DEKALMÄRKET NU OM MODELLEN INTE SKA MALAS  
 • ORA AGGIUNGERE DECALCOMANIA SE NON SI DIPINGE IL MODELLO

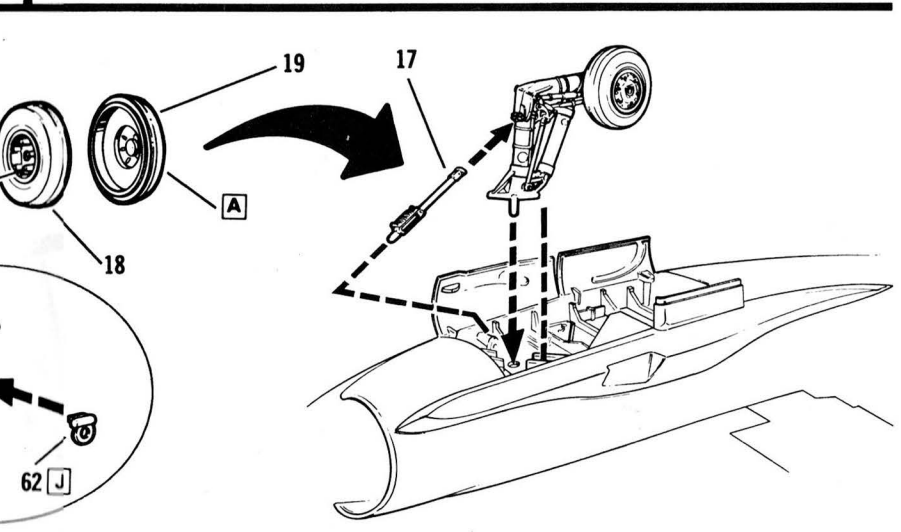
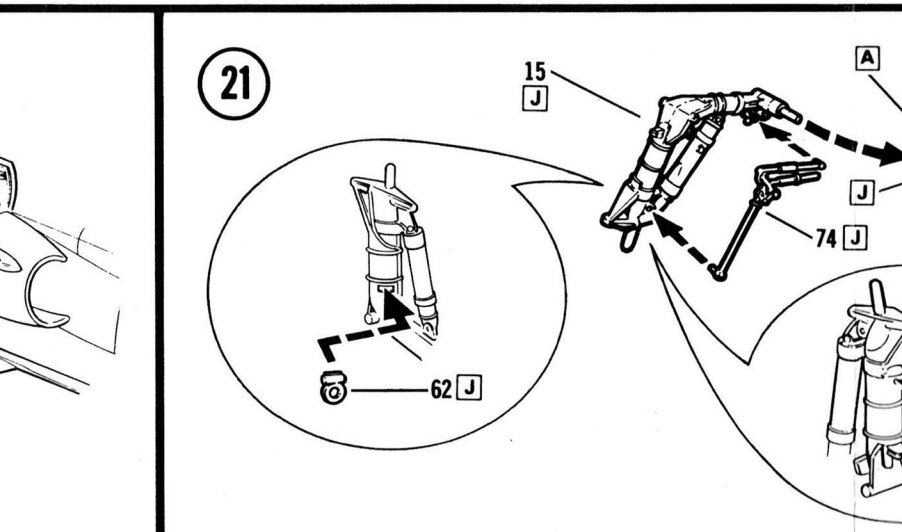
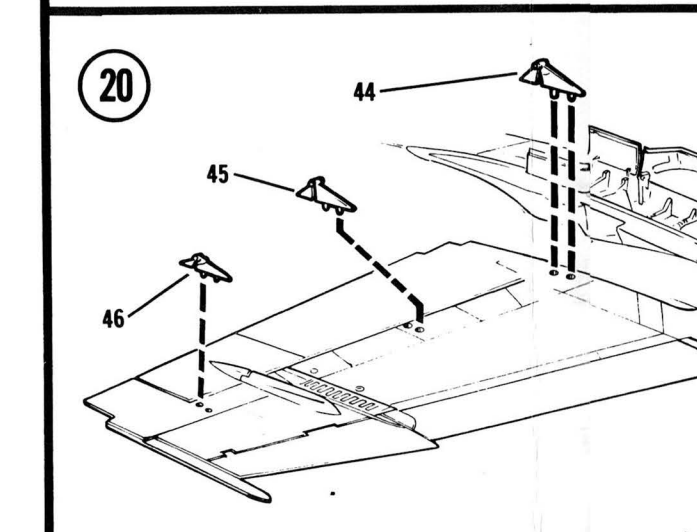



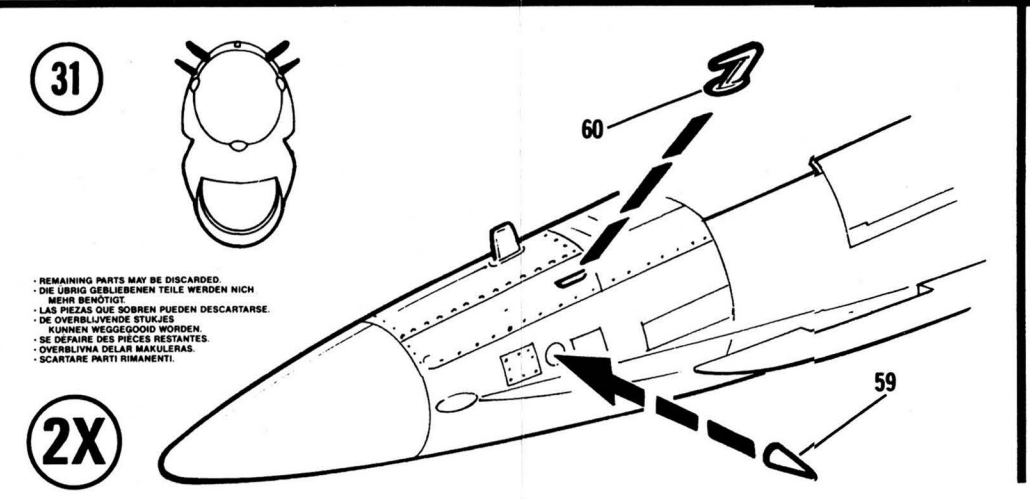
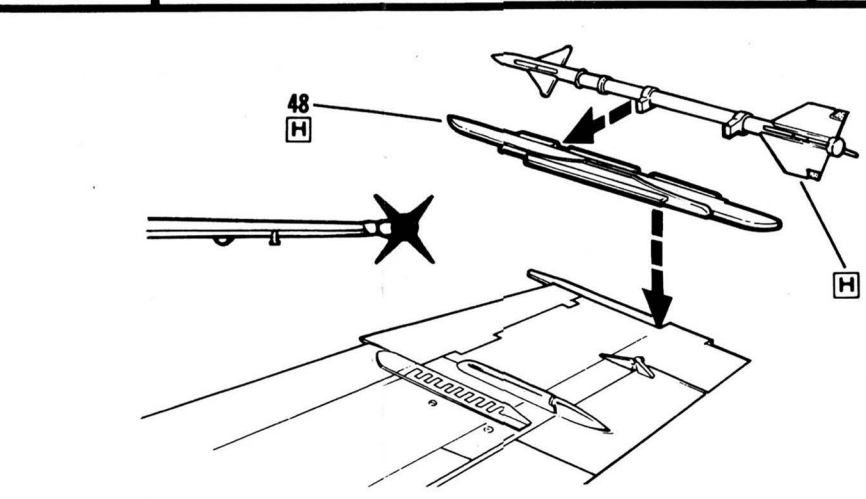
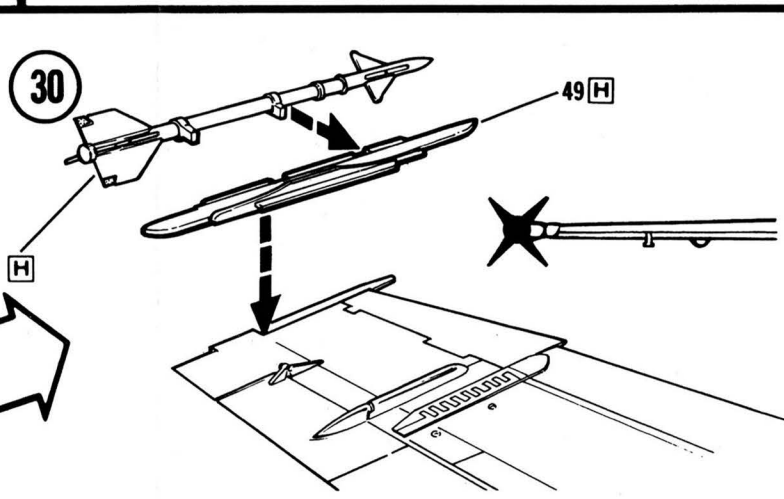
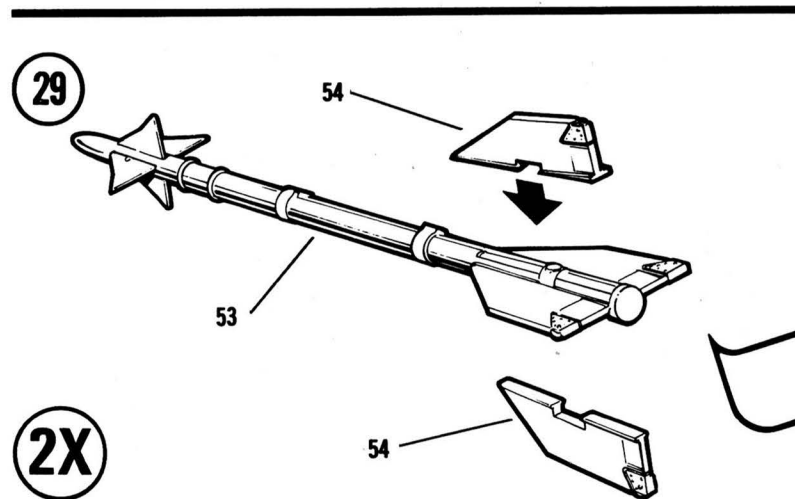
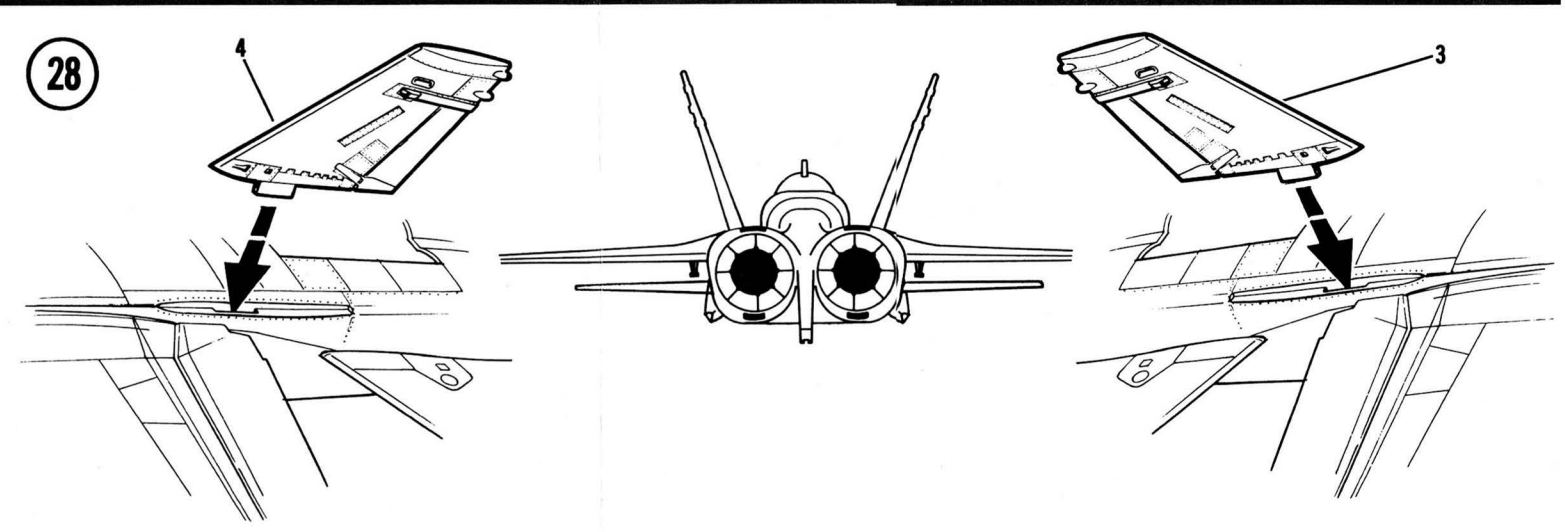
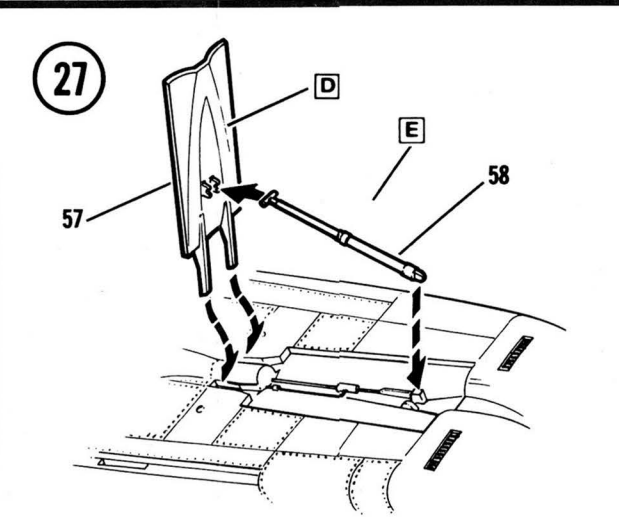
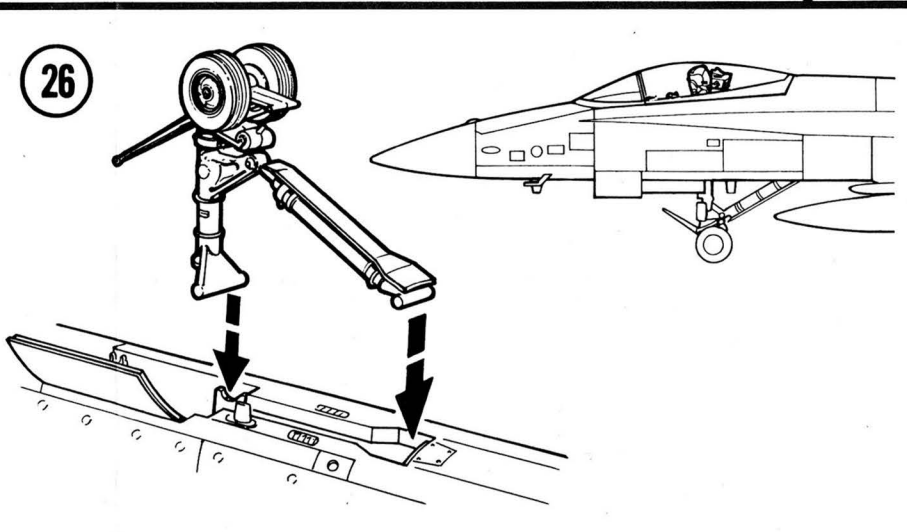
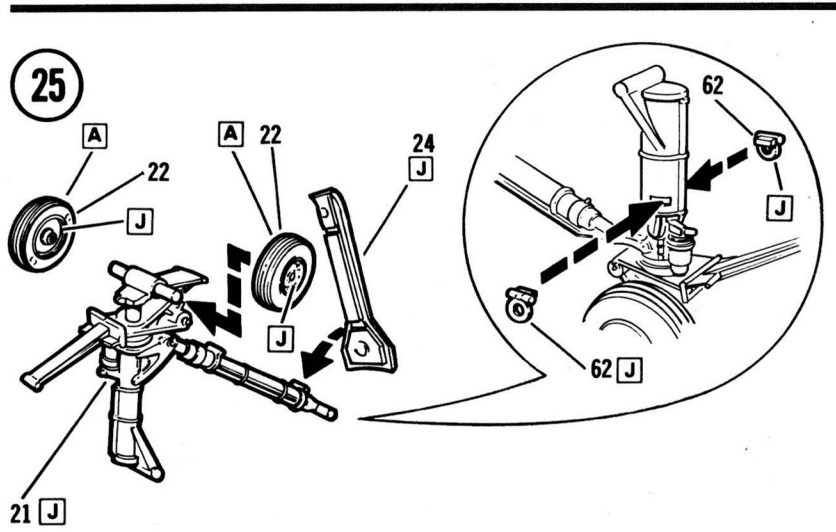
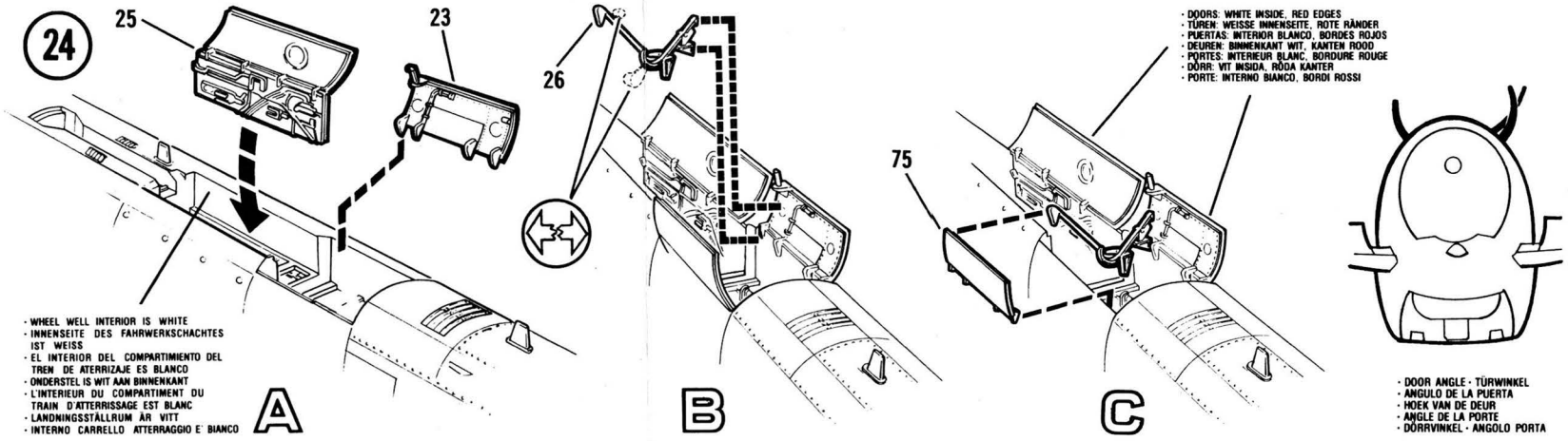
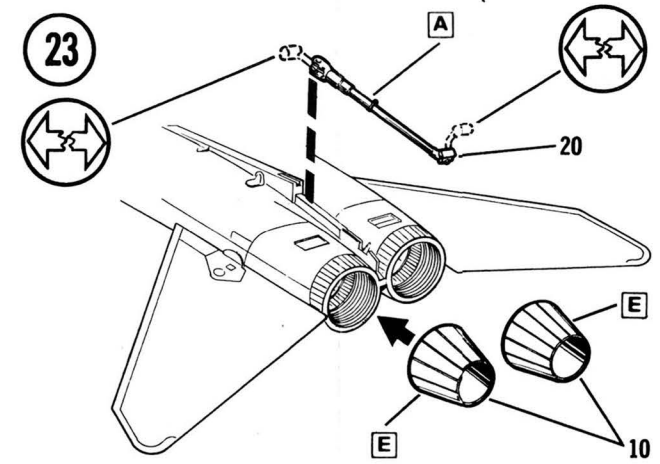
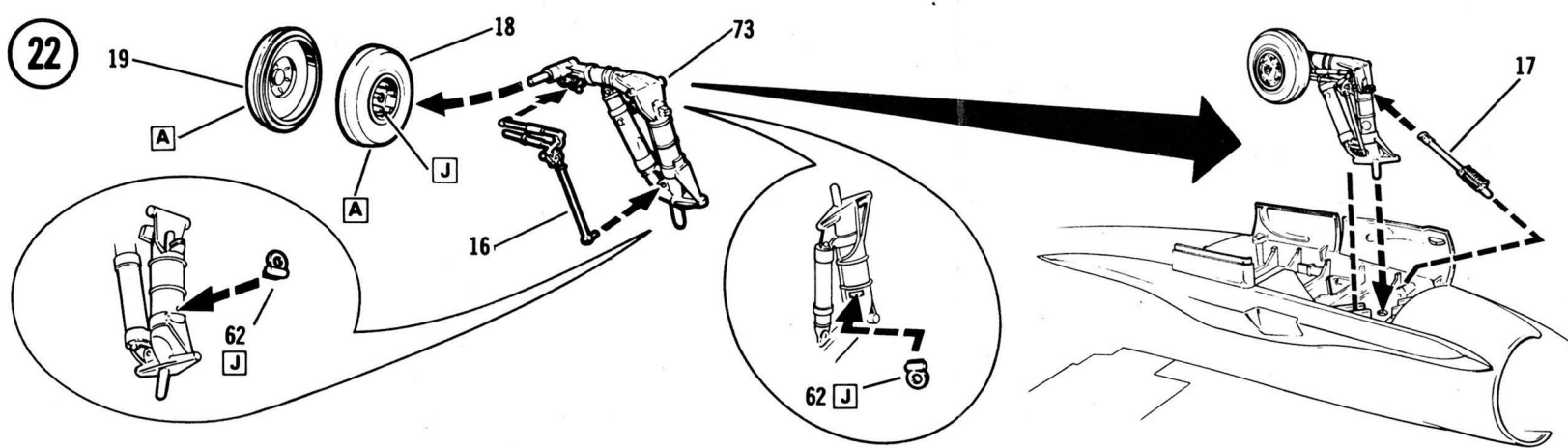

**BLUE ANGELS' F-18 HORNET**  
KIT 5820

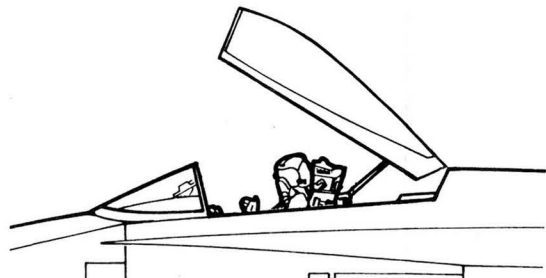
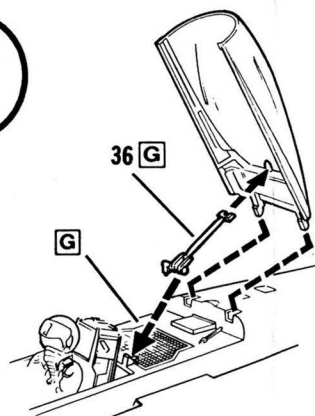
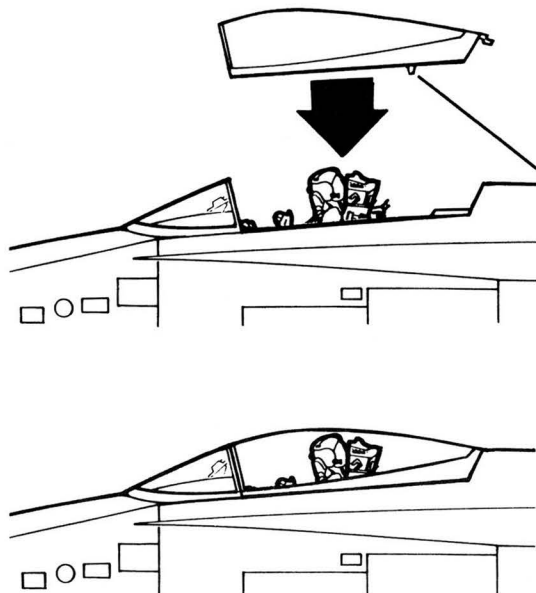
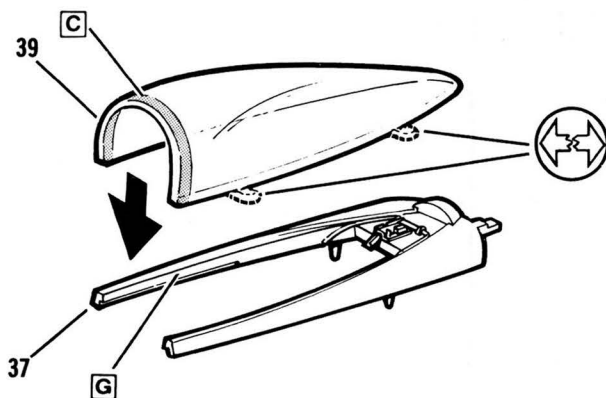
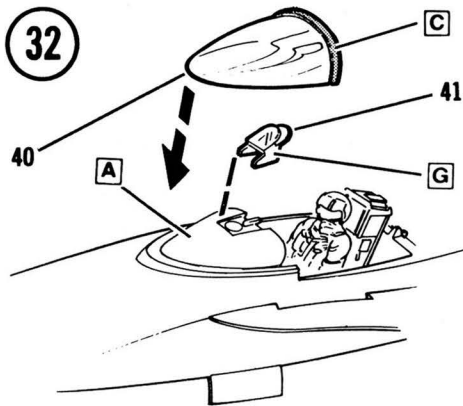

- CANOPY DETAIL—MASK ENTIRE CANOPY WITH A DULL FINISH ACETATE MENDING TAPE. CAREFULLY CUT THE TAPE FROM AREAS TO BE PAINTED. PAINT THE EXPOSED PARTS AND ALLOW TO DRY. REMOVE THE REMAINING TAPE.
- FÜR DAS KUPPELDACH—DAS GESAMTE KUPPELDACH MIT MATTEM AZETATKLEBSTREIFEN VERKLEIDEN. DEN KLEBSTREIFEN SORGFÄLTIG VON DEN ZU STREICHENDEN FLÄCHEN ABSCHNEIDEN. DIE FREIEN TEILE STREICHEN UND TROCKNEN LASSEN. DEN ÜBRIGEN KLEBSTREIFEN ENTFERNEN.
- DECORACION DE LA CARLINGA—CUBRIR ENTERAMENTE LA CARLINGA CON LA CINTA DE PEGAR DE COLOR ACETATO APAGADO. RECORTE CUIDADOSAMENTE LA CINTA. DE LAS AREAS A SER PINTADAS. PINTÉ LAS PARTES QUE QUEDEN EXPUESTAS Y DEJE SECAR. RETIRE LA CINTA DE PEGAR.
- DETAILLE VAN KOEPELDAK—BEDEK DE GEHELE KOEPELDAK MET DOF GLANZENDE ACETATE VERSTEL BAND. KNIP DE BAND MET ZORG UIT VAN DE TE VERVEN OPPERVLAKTEN. VERF DE NIET BEDEKTE DELEN EN LAAT ZE DROGEN. VERWIJDER DE OVBRLIJFENDE BAND.

- FINITION DE LA VERRIERE—COUVRIR ENTIEREMENT LA VERRIERE AU MOYEN DE RUBAN ADHESIF D'ACETATE MAT. DEGAGEZ LES ZONES A PEINDRE EN DECOUPANT LE RUBAN AVEC SOIN. PEINDRE LES SURFACES DEGAGEES ET LAISSER SECHER. ENLEVER LE RUBAN RESTANT.
- HUVDEKORERING—MASKERA HELA HUVEN MED EN MATTBEHANDLAD ACETATE LAGNINGSTEJP. SKÅR FÖRSIKTIGT BORT TEJPEN FRÅN OMRADEN SOM SKALL MÅLAS. MÅLA DE FRILAGDA YTORNA OCH LÅT TORKA. TA BORT KVARVARANDE TEJP.
- DETTAGLIO CALOTTA—MASCHERARE O'INTERA CALOTTA CON UN NASTRO IN ACETATO A FINITURA OPACA. RITAGLIARE ACCURATAMENTE IL NASTRO DALLE AREE DA DITINGERE. DITINGERE LE PARTI ESPOSTE E LASCIAR ASCIUGARE. TOGLIERE IL NASTRO RIMANENTE.



ACKNOWLEDGEMENT - THIS ACCURATELY DETAILED MODEL WAS DESIGNED FROM AUTHENTIC DRAWINGS AND PHOTOGRAPHS  
TECHNICAL INFORMATION WAS SUPPLIED BY McDONNELL DOUGLAS CORPORATION, ST. LOUIS, MISSOURI.

