

GERMAN HEAVY TANK
Pz.Kpfw. VI, Ausf.E (Sd.Kfz. 181)
Tiger I
Middle production version
-Basic set

Niemiecki ciężki czołg Tiger I, pośrednia wersja
 - zestaw podstawowy
 1/16 scale update fit to Hobby Boss

ABER

16 050

WWW.ABER.NET.PL

Made in Poland © 2013

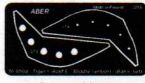
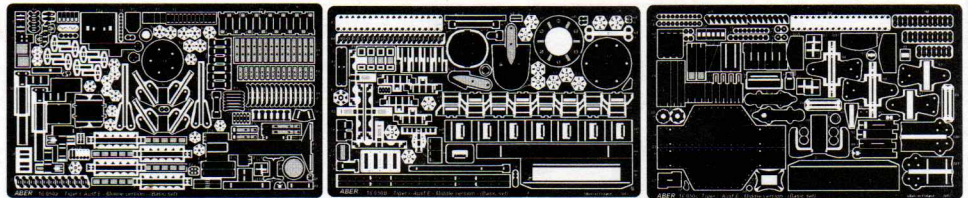

Brass rod 1mm

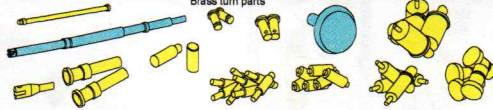

Brass turn parts

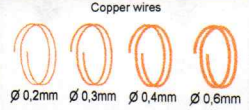

Copper wires

Ø 0,2mm Ø 0,3mm Ø 0,4mm Ø 0,6mm

WARNING
 Any unauthorized copying, producing and reproducing of ABER company products, or any part thereof, is strictly prohibited and any such action establishes liability for a civil action and may give rise to criminal prosecution.

Please note that, for purpose of improvement ABER sets designs are subjects to change without notice.
 Proszę mieć na uwadze fakt, że zestawy ABER mogą ulec zmianie ze względu na ulepszenia, bez powiadomienia.

OSTRZEŻENIE
 Jakiegokolwiek kopiowanie, produkowanie i reprodukcja wyrobów firmy ABER bez zezwolenia, w całości lub części jest surowo zabronione. Powyższe działania powodują powstanie odpowiedzialności cywilnej oraz mogą spowodować wszczęcie postępowania karnego.

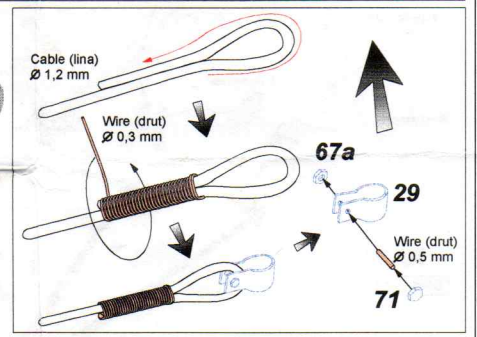
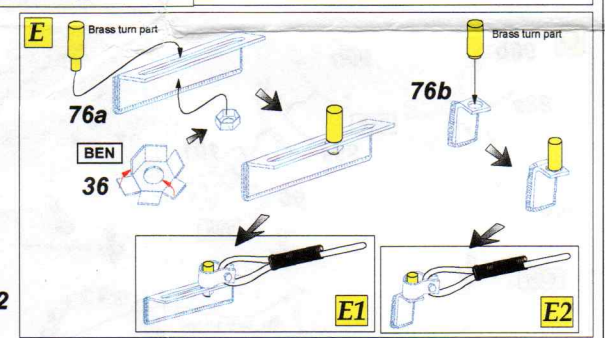
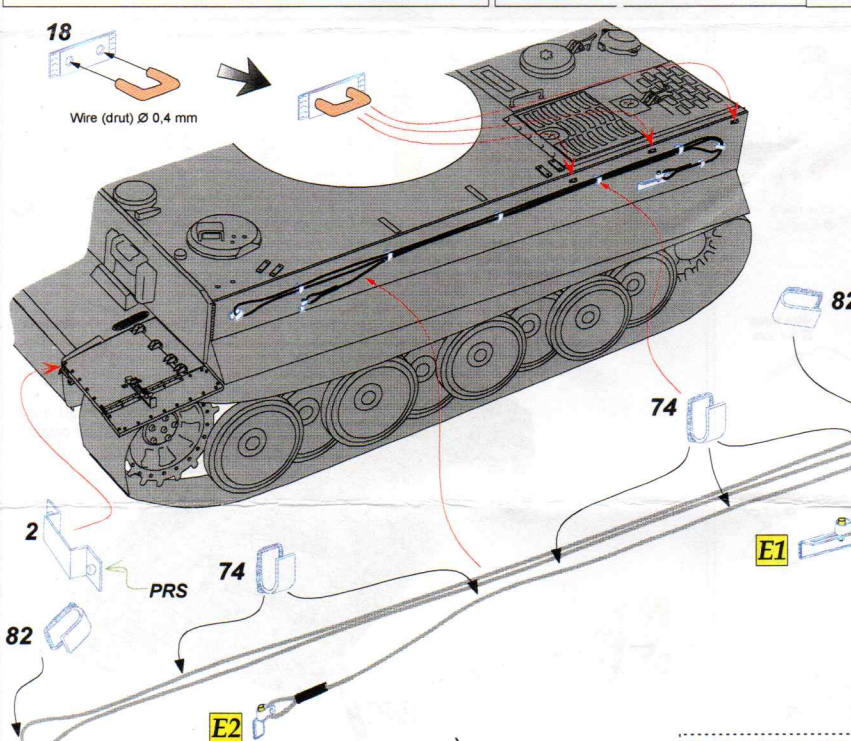
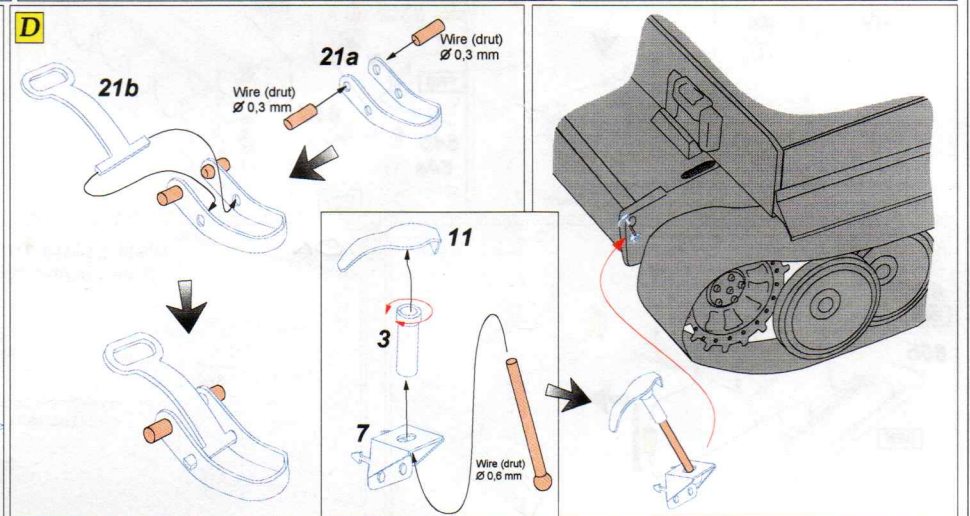
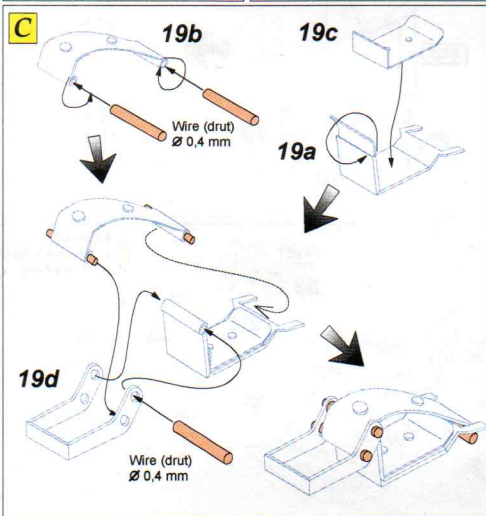
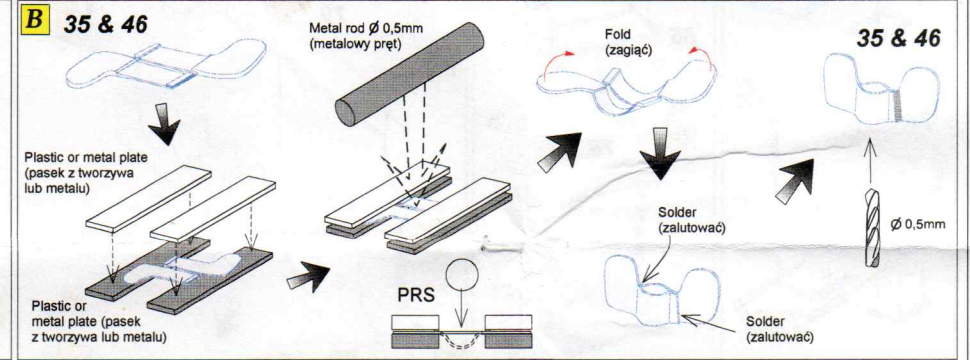
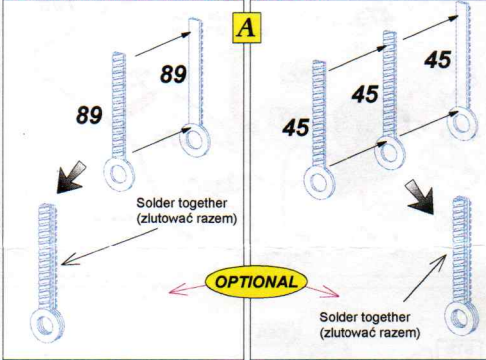

We advise that better method to join metal to metal is soldering. Use ABER soldering solution AF20 (doradzamy łączenie części metalowych za pomocą lutownia. Zastosuj nasz topnik AF20)

- Separately sold (oddzielnie w sprzedaży):
- 16 004 -Front fenders Tiger I, Ausf.E (Early/Late version)
 - 16 006 -Side fenders Tiger I, Ausf.E (Early/Late version)
 - 16 007 -Exhaust covers Tiger I, Ausf.E (Early/Late version)
 - 16 012 -8,8 cm Tiger I A/T Ammo with box
 - 16 032 -German 2 meter standard Antenna
 - 16 051 -Rear fenders Tiger I, Ausf.E (Late version)
 - 16 L-03 - German barrel for tank machine gun MG 34 with Panzermantel

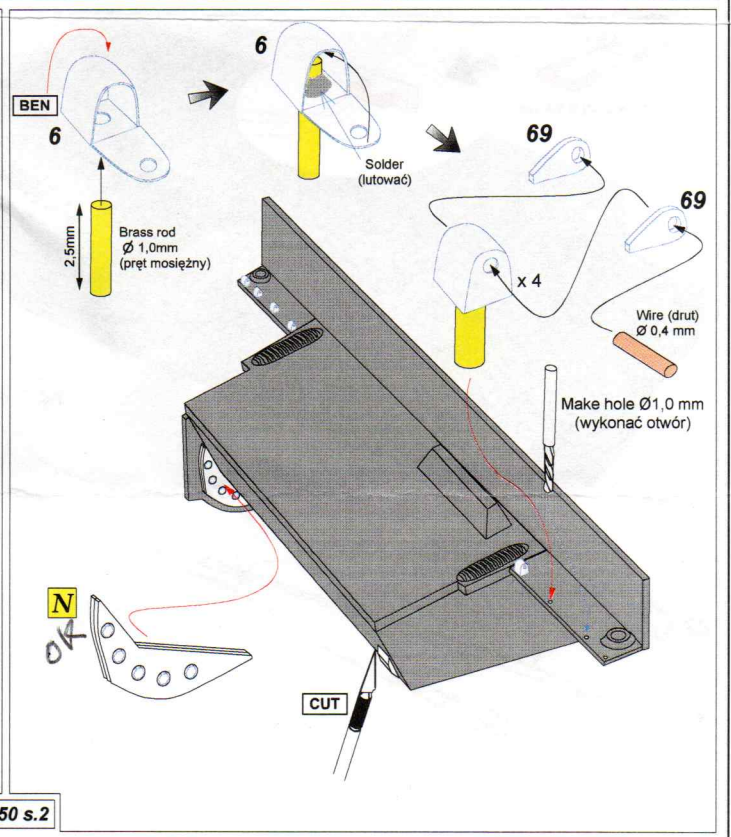
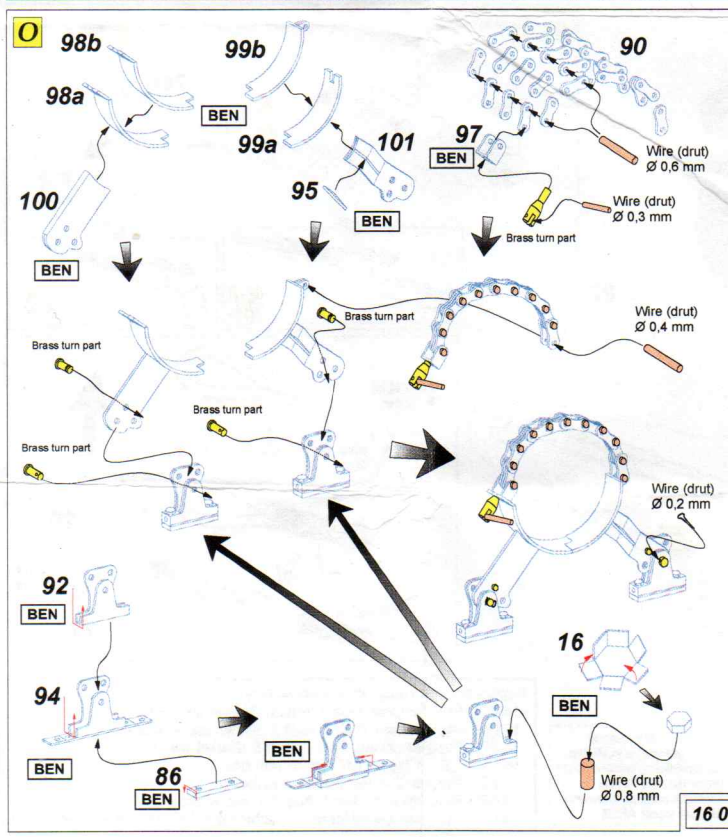
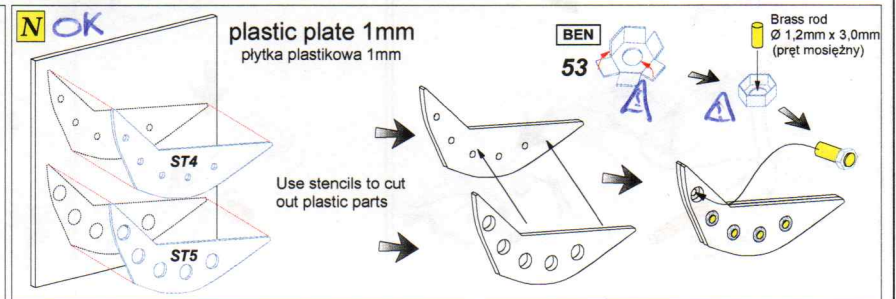
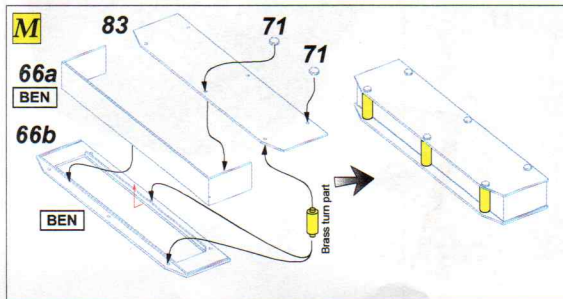
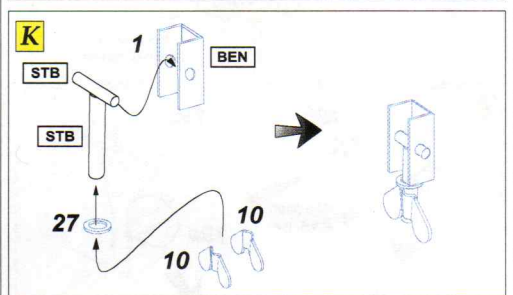
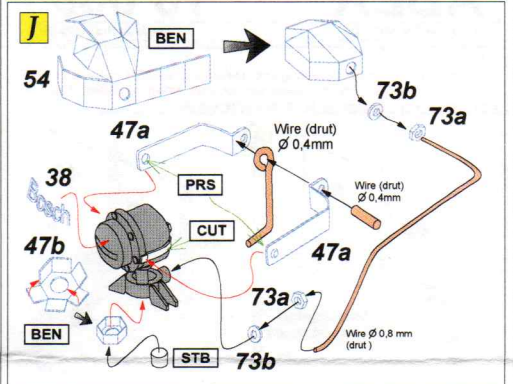
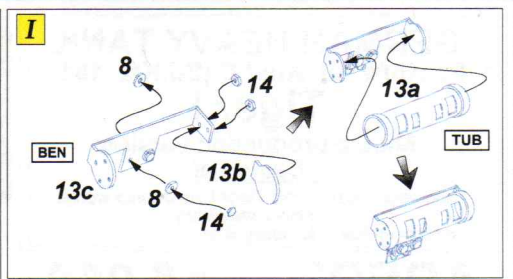
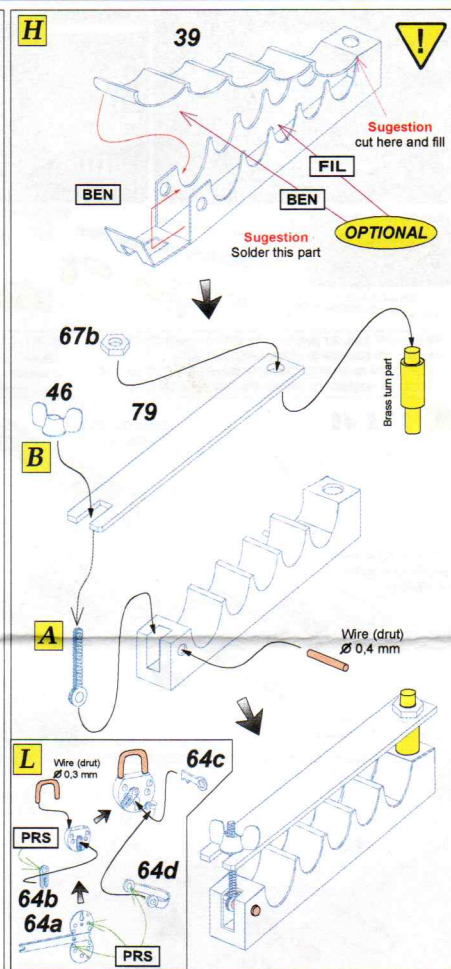
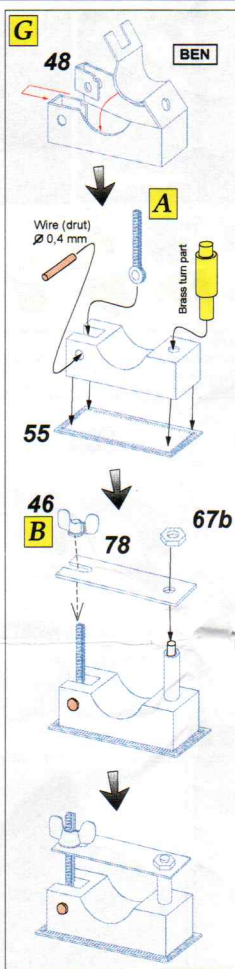
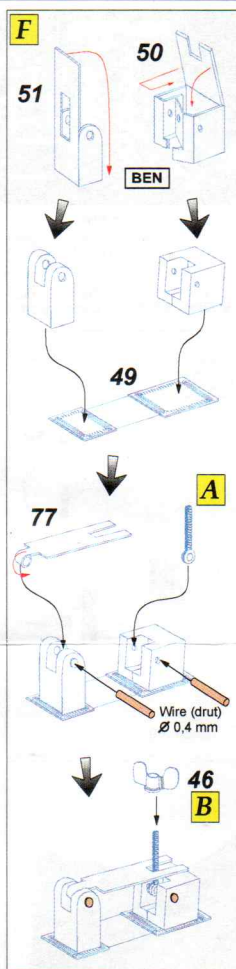

P 57c PRS

Make form wooden block
(wykonać z drewna)

57a Wire (drut) \varnothing 0,5 mm PRS

57c BEN PRS

D 57d BEN

57b BEN

87 PRS

Q 62c PRS

Wire (drut) \varnothing 0,4 mm

62b

62c

62f PRS

62e

62a

24b

62d

C

R 44 BEN

20

C

BEN

S

C

28

24a BEN

T

C

17

41a

41b PRS

U **C** 56

24b BEN

56

V 43B 72 PRS 72

43M

43G

43K

43I

43E BEN

43L

43H BEN

43A

43C

43F

43D

Wire (drut) \varnothing 0,5mm

Wire (drut) \varnothing 0,3mm

67b

Wire (drut) \varnothing 0,5mm

Reworked kit part (przerobiona część z modelu)

W 85b PRS 81a

85d

85c

80b

9

9

32

TUB

80a

80c

80d

85a

85e

85c

85d

81c

84

BEN

Wire (drut) \varnothing 1,0 mm

Wire (drut) \varnothing 0,4 mm

Wire (drut) \varnothing 1,0 mm

Reworked kit part (przerobiona część z modelu)

X Brass turn parts

68a

68b

35 B

68b

35 B

Y 30

31

75a

35 B

37b

37a

37b

33

Wire (drut) \varnothing 0,4 mm

Wire (drut) \varnothing 0,4 mm

16 050 s.3

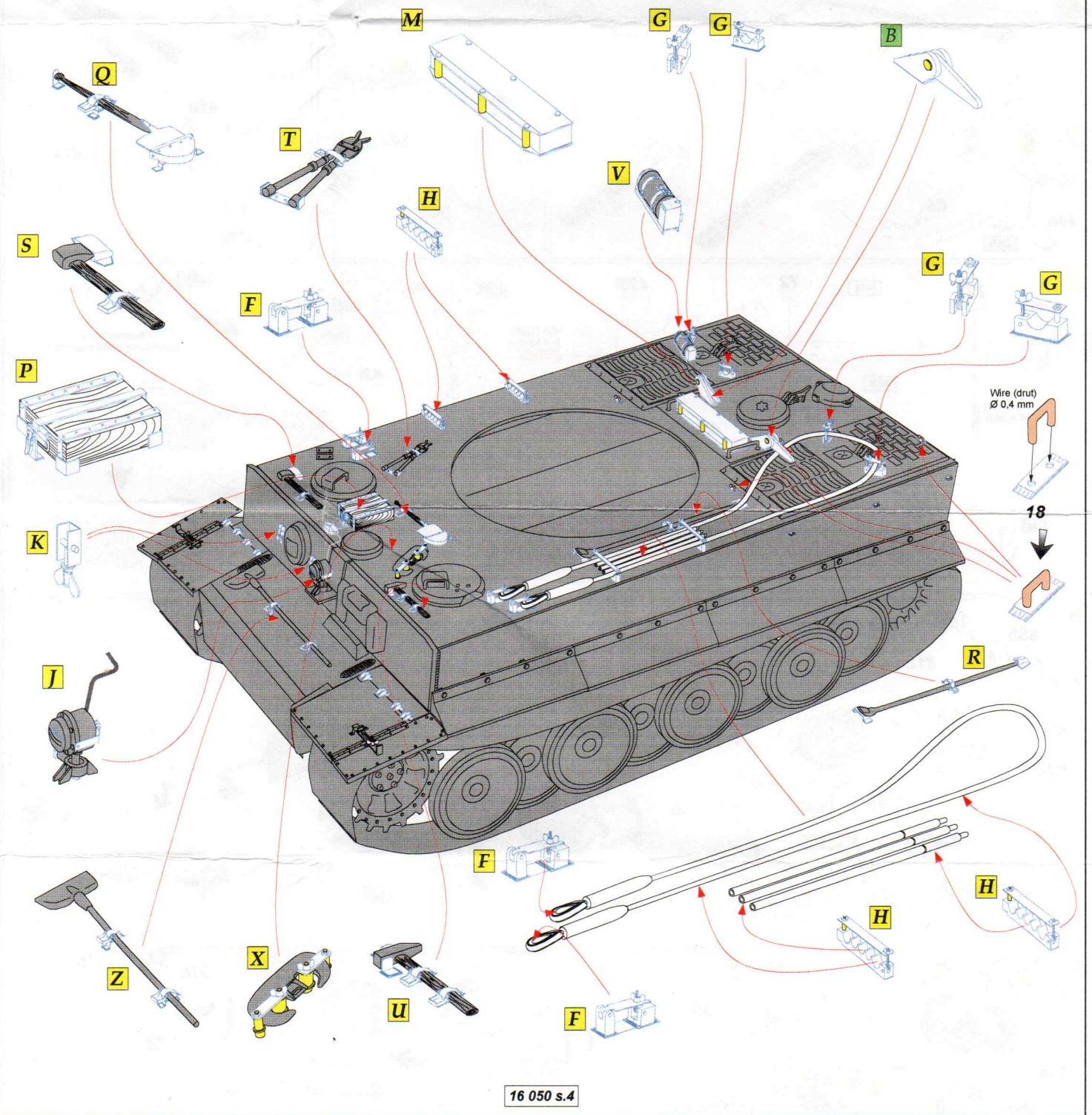
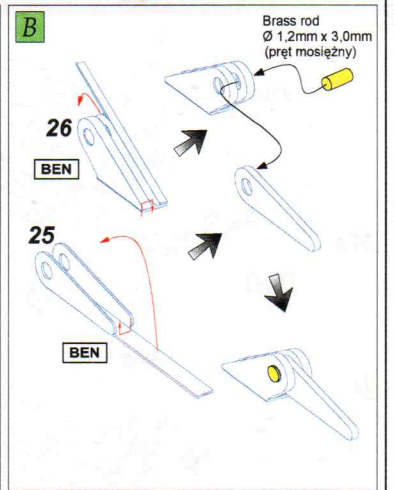
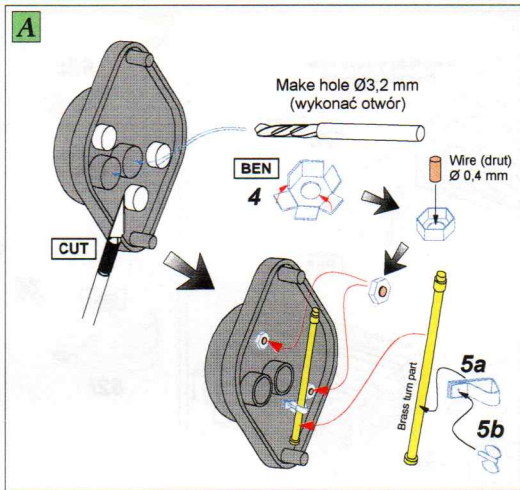
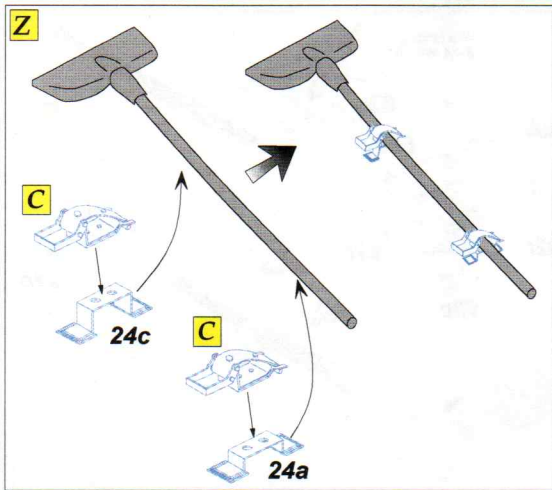

A3

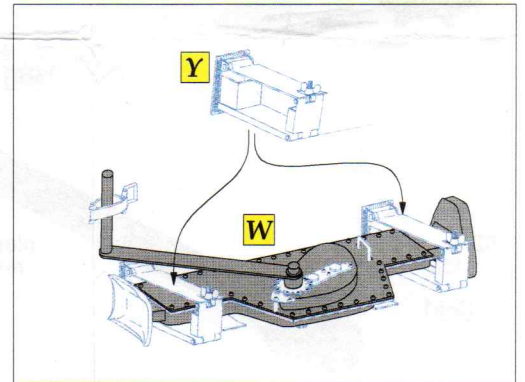
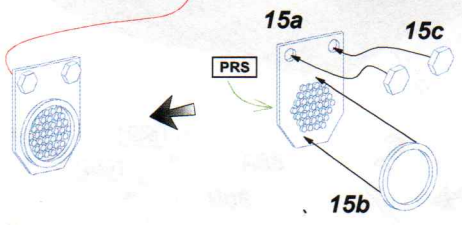
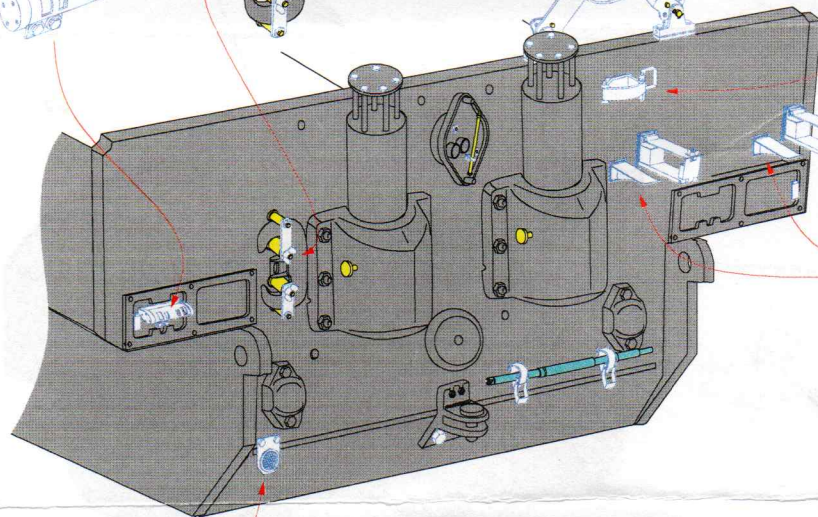
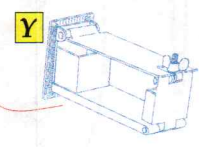
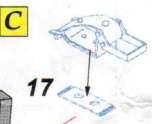
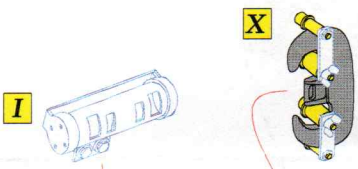
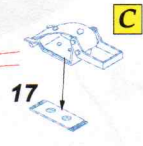
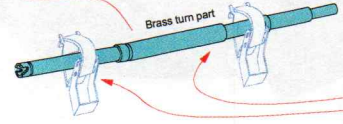
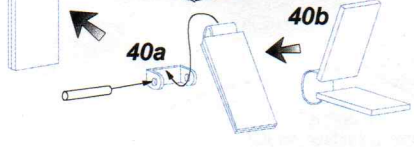
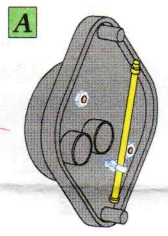
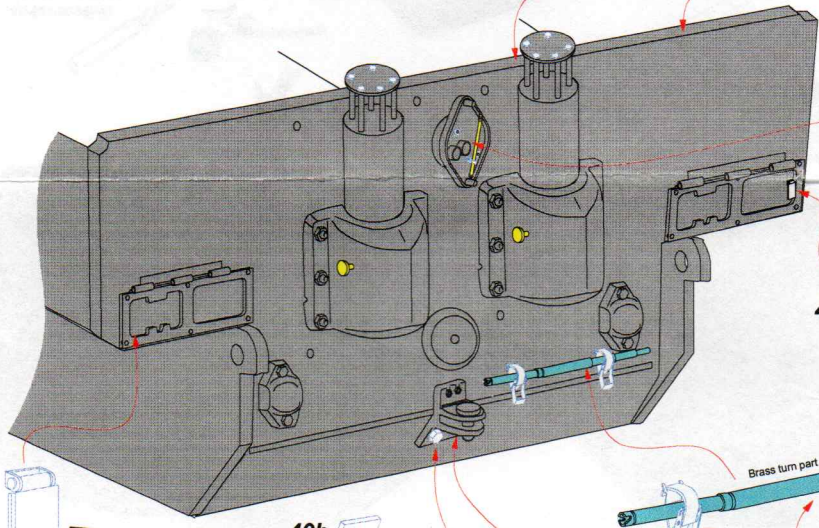
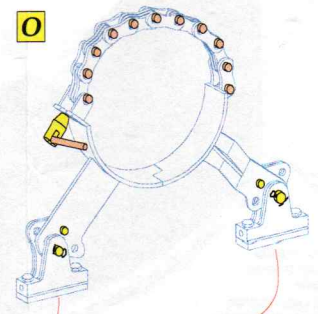
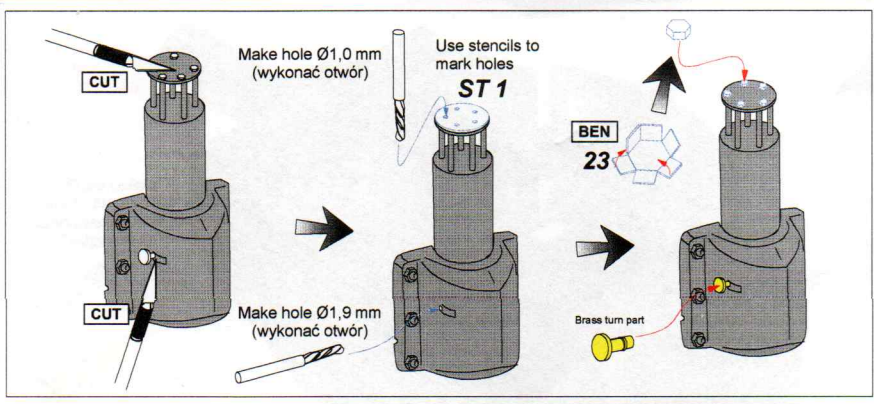

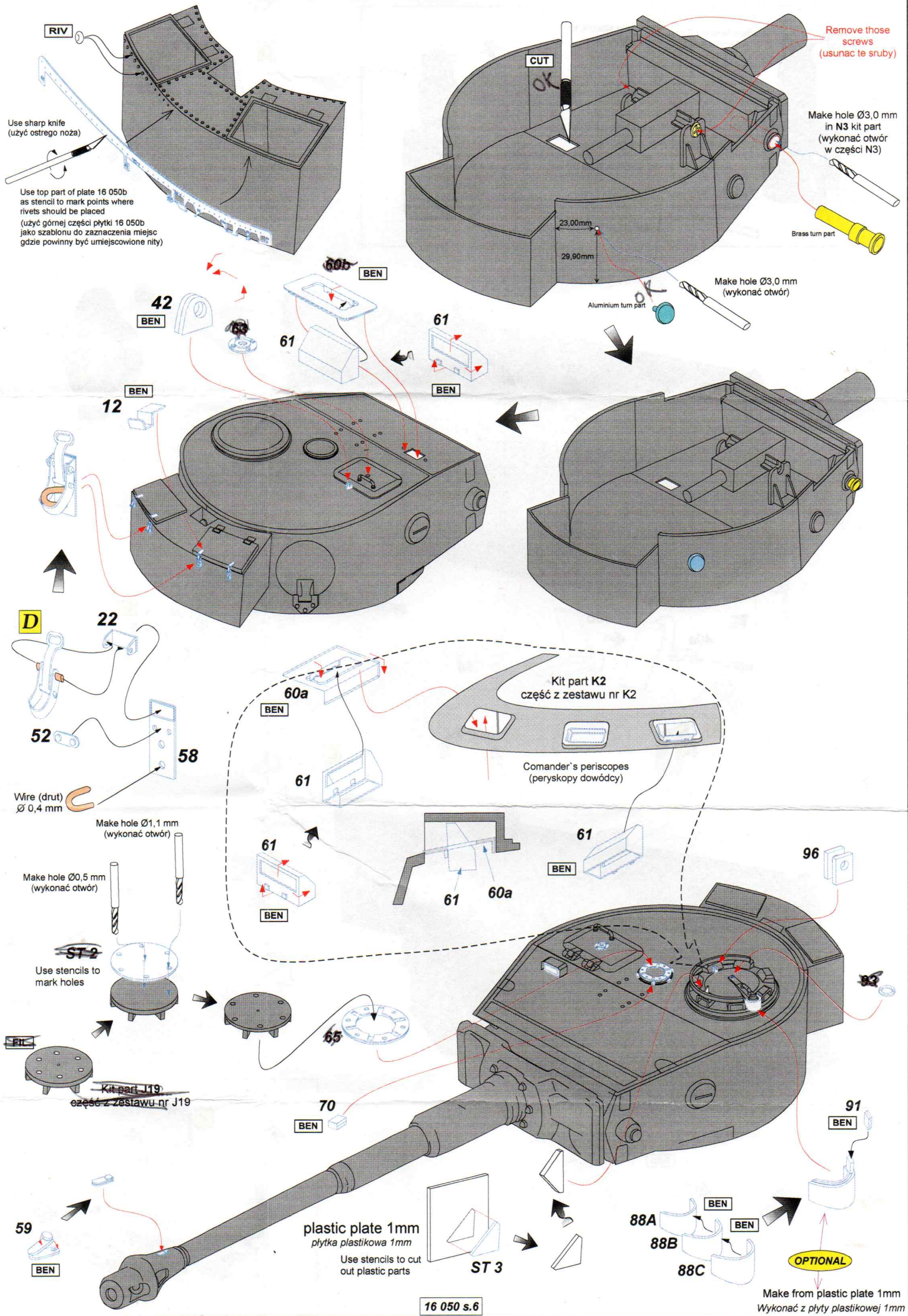

Remove those screws (usunac te sruby)

Make hole Ø3,0 mm in N3 kit part (wykonać otwór w części N3)

Brass turn part

Make hole Ø3,0 mm (wykonać otwór)

Aluminium turn part

Kit part K2 część z zestawu nr K2

Comander's periscopes (peryskopy dowódcy)

RIV

Use sharp knife (użyć ostrego noża)

Use top part of plate 16 050b as stencil to mark points where rivets should be placed (użyć górnej części płytki 16 050b jako szablonu do zaznaczenia miejsc gdzie powinny być umieszczone nity)

42 BEN

60b BEN

61 BEN

12 BEN

D

22

52

58

Wire (druć) Ø 0,4 mm

Make hole Ø1,1 mm (wykonać otwór)

Make hole Ø0,5 mm (wykonać otwór)

ST 2

Use stencils to mark holes

Kit part J19 część z zestawu nr J19

60a BEN

61 BEN

61 BEN

61

60a

61 BEN

96

70 BEN

91 BEN

59 BEN

plastic plate 1mm płytka plastikowa 1mm

Use stencils to cut out plastic parts

ST 3

88A BEN

88B BEN

88C

OPTIONAL

Make from plastic plate 1mm Wykonać z płytki plastikowej 1mm