

Acknowledgements:

We would like to express our gratitude to Tom Cooper and Leon Manucherians for their kind assistance provided during the preparation of this decal sheet.

Recommended references:

- *"Les Tigres du Shah"* by Farzad Bishop and Tom Cooper, in *"Le Fana de l'Aviation"* N° 418 & N° 419. Editions Larivière 2004.
- *"La Guerre Iran-Irak - les combats aeriens"* by Farzad Bishop, Tom Cooper and Brig. Gen. Ahmad Sadik. *"Avions hors série"* N° 22 & N° 23, Editions Lela Presse 2008.
- *"Iranian Aviation Revue"* N° 2 & N° 3, Top Kit Publishing 2010.
- *"IRIAF 2010 - The Modern Iranian Air Force"* by Tom Cooper, Babak Taghvaei and Liam F. Devlin, Harpia Publishing 2010.

Recommended model kits:

1/48: AFV Club, Monogram, Revell
 1/72: Italeri, Revell, Trumpeter, Airfix

Color and marking notes:

The IRIAF F-5E/F fleet wears faded standard Asia Minor camouflage as applied on delivery. During the long service years, maintenance markings were reduced to a minimum and now only very few stencils can be seen on the airframes.

Weapon load:

The standard combat load of IRIAF F-5Es and Fs consisted in a centreline fuel tank and 2 AIM-9P AAMs. For CAS missions 4 BLU-27 napalm tanks were also frequently used early during the war against Iraqi ground formations, but were largely replaced by 4 Mk.82SE bombs with Snakeye retarding fins during later stages of the conflict. Sometimes 4 LAU-3 unguided rocket pods were also carried.

		Humbrol	Model Master
A	Dark Green FS34079	116	1710
B	Dark Brown FS 30140	186 + 119 75% + 25%	1701 + 1742 75% + 25%
C	Sand FS 30400	63 + 34 90% + 10%	2021
D	Light Grey FS 36622	28	1733
E	Tan FS 30219	119	1742
F	Radome Black FS 27038	85	1597
G	White FS 27875	130	1596
H	Aluminium	27002	1401
I	Steel	27003	1405

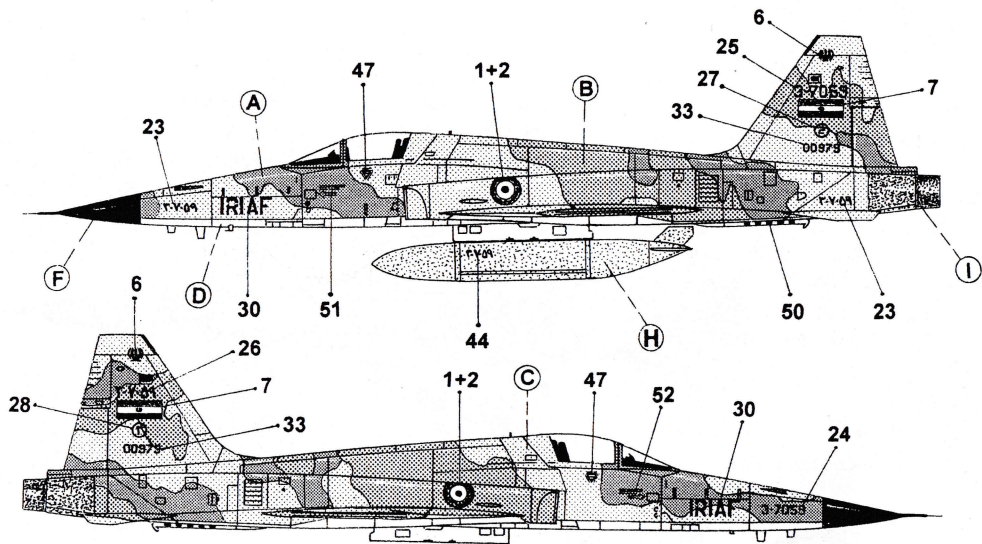

1 F-5E 73-00939 / 3-7059, 21st TFS, Islamic Iranian AF, TFB.2 Tabriz, 1984.
 This Tiger II was credited with at least 3 victories during the Iran-Iraq War. It was also the favourite mount of Col. Javadpour, who downed 2 IrAF Su-20s when flying this jet. For most of the war, IRIAF F-5Es were relegated to air-to-ground missions, but, in June 1986, Col. Javadpour managed to intercept and damage an Iraqi MiG-25PDS returning from a mission deep within Iranian airspace.

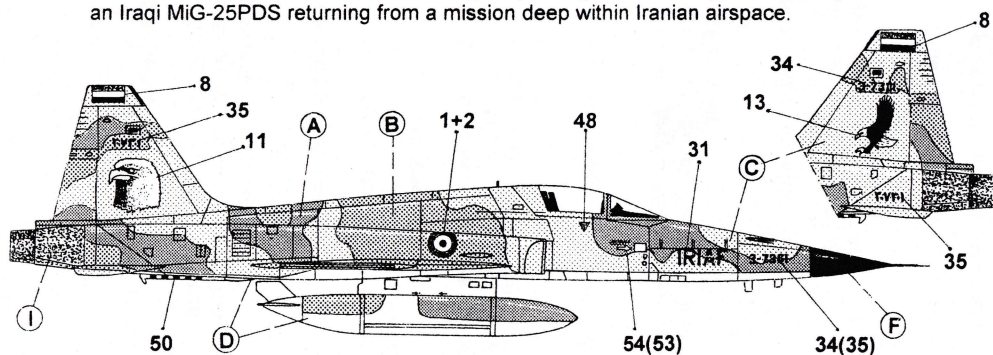

2 F-5E 3-7301, 41st TFS, Islamic Iranian AF, TFB.4 Vahdati, 2010.
 The oldest F-5E in Iranian service and an Iran-Iraq War veteran, 3-7301 was stored for more than 15 years and returned to service after an overhaul in 2007. Squadron markings, in form of a bald eagle head, were applied on the starboard tail side of the 41st TFS F-5Es in October 2009.

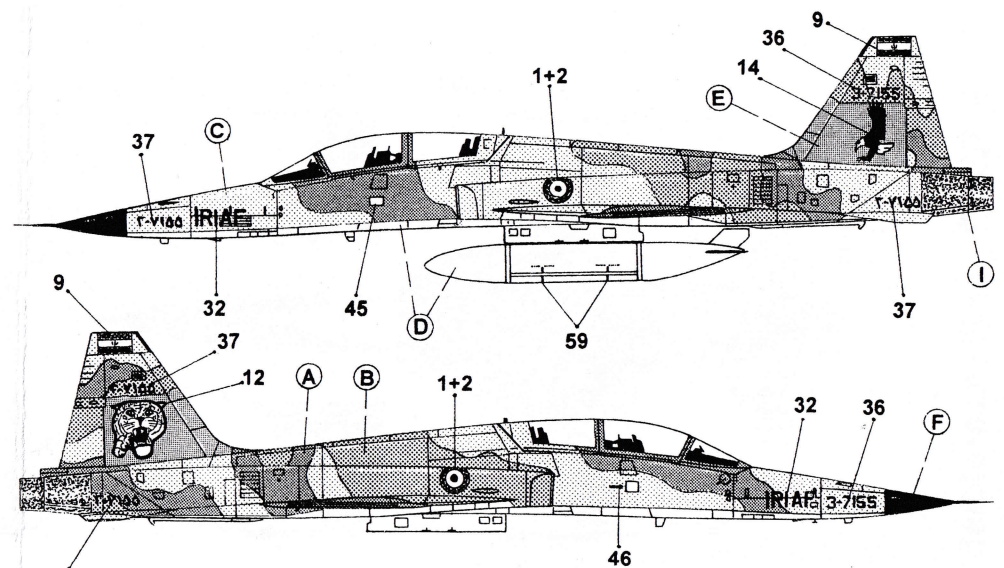

3 F-5F 75-00682 / 3-7155, 43rd TFS, Islamic Iranian AF, TFB.4 Vahdati, 2010.
 3-7155 was only the second F-5F build for Iran, The jet flew dozens of combat missions during the Iran-Iraq War and served with the 41st TFS from 1976 until 2009, when it was reassigned to the 43rd TFS. The 43rd TFS nickname being "The Tigers", all the units F-5E and Fs now wear tiger head insignia on the starboard side of their fins.

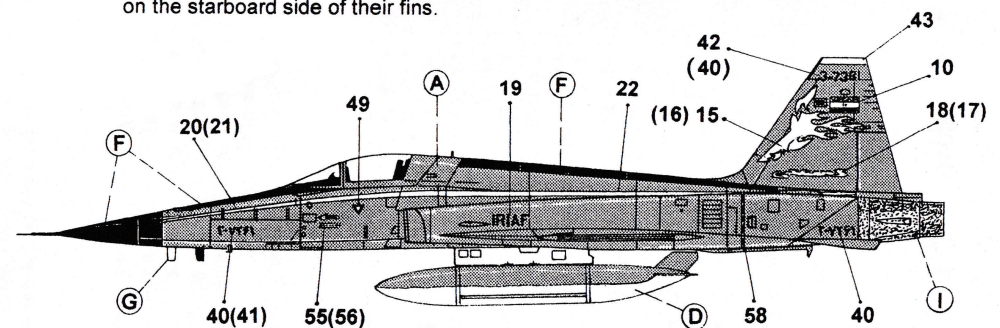

4 F-5E Azarakhsh 3-7361, 41st TFS, Islamic Iranian AF, TFB.4 Vahdati 2010.
 3-7361 is one of the few F-5Es modified under Project Azarakhsh, launched in the 1990s by HESA with the intention of upgrading the aircraft's cockpit layout, fire control system, avionics and armament. The most noticeable external differences are the deletion of the starboard nose gun as well as RWR antennas and chaff/flares dispensers on the rear fuselage.