

GERMAN WWII LIAISON PLANE 1:48 SCALE PLASTIC KIT



eduard

intro

ProfiPACK



The BFW Company (latter Messerschmitt A.G.) designed the Messerschmitt Bf 108 Taifun in 1934. The original design was for a light tourist double seater, developed for the German team taking part in the 1934 international air race Challenge. Even though the Challenge wasn't a great success for the Bf 108 as the best German pilot Theo Osterkamp only came in fifth, the RLM still ordered 32 Bf 108s.

The production of the improved version, the Bf 108B, was set-up in November 1935. The B version was redesigned to be a four-seater with a new Argus As 10C engine. The Bf 108B was a very modern light aircraft with an all-metal airframe, retractable undercarriage, adjustable propeller, and with excellent flight characteristics. The Bf 108 took part in many air races and record flights and the first foreign pilot who tested the Bf 108 was Charles Lindberg. He said that it was one of the world's best aircraft in its class.

The military version of the Taifun was the Bf 108B-2 and was acquired by the Luftwaffe in 1939. It was widely employed during the war years by all operational Luftwaffe units as a light liaison aircraft. In 1941 the new version, the Bf 108D, replaced the B version on the production line. An Argus As 10R engine powered the D version and included the new Argus automatically adjustable propeller and improved fuel assembly. The production was transferred to France in 1942, where 170 Bf 108D were completed before the liberation of France in 1944. French production continued after the war where another 115 aircraft under the name of "Nord 1000" were manufactured.

In total 626 military Taifuns, versions B-2 and D-1, were produced except at least 180 civilian or export version Bf 108 B-0 and B-1. The Luftwaffe employed most of them, but many other air forces used this fine and popular aircraft. The Hungarian AF had 8 Taifuns, both the Italians and Rumanians had 3, the USSR bought two and Switzerland and Yugoslavia had 12 each. One aircraft was used in Chile, one or two in Japan and one was in Australia. The Bulgarian AF had 6 and at least one was in Spain. One Bf 108B-1, coded XC44, was operated by the US embassy in Berlin. Two Bf 108B-1s were flown by the German embassy in London but the RAF confiscated these two aircraft in 1939. After the war, one Bf 108B-2 was flown in Czechoslovakia, two in Poland, one in Denmark and one in Sweden. Some 115 Bf 108Ds (Nord 1000) were used by the French AF and Navy until the late 50's. Many of the surviving Taifuns were flown a long time after the war, and some of them are still in airworthy condition today.

intro

Messerschmitt Bf 108 Taifun byl zkonstruován firmou BFW, konstrukčním týmem pod vedením ing. Williho Messerschmitta v roce 1934. Letoun původně vznikl jako lehká turistická dvousedadlovka pro německý reprezentační tým, účastníci se mezinárodních závodů Challenge 1934. Ačkoliv tento závod nebyl pro Bf 108 úspěšný, RLM objednalo u BFW výrobu 34 letadel.

Produkce vylepšené verze Bf 108B byla zahájena v listopadu 1935. Konstrukce byla celkově zvětšena, stroj byl nyní čtyřmístný a dostal nový motor Argus As 10C. Bf 108B byl velmi moderní lehký letoun, s celokovovou konstrukcí, zatahovacím podvozkem a stavitelnou vrtulí, s vynikajícími letovými charakteristikami. Díky svým vynikajícím výkonům dosáhl Bf 108B na konci třicátých let řady úspěchů v mezinárodních závodech a rekordních letech. První zahraniční pilot, testující Bf 108B byl Charles Lindberg, který ho označil za nejlepší letadlo této třídy na světě.

Vojská verze byla Bf 108B-2, přijata do výzbroje Luftwaffe v roce 1939. Bf 108 byl používán po celou válku prakticky všemi operačními jednotkami Luftwaffe jako lehký spojovací a kurýrní letoun. V roce 1941 byla verze B nahrazena ve výrobě novou verzí D. Ta byla poháněna motorem Argus As 10R s novou automaticky stavitelnou vrtulí Argus. Měla také upravenou palivovou instalaci. V roce 1942 byla výroba převedena do Francie, kde bylo až do osvobození v roce 1944 vyrobeno 170 Bf 108D. jejich výroba pokračovala i po válce produkcí 115 strojů značených Nord 1000. Celkem bylo vyrobeno 626 kusů vojenských verzí Bf 108B-2 a D-1, mimo to ještě nejméně 180 civilních strojů verze B-0 a B-1. Většinu z nich používala Luftwaffe, typ byl ovšem používán i v řadě dalších zemí. 8 Taifunů mělo maďarské letectvo, 3 Italské, 3 Rumunské, dva stroje zakoupil SSSR, 12 Švýcarsko, 12 Jugoslávie. Jeden stroj byl v Chile, jeden nebo dva v Japonsku, jeden v Austrálii. 6 Bf 108 mělo bulharské letectvo, nejméně jeden stroj byl ve Španělsku. Jeden Bf 108B-1, značený XC-44 byl zakoupen vládou USA pro vojenského přídělence v Berlíně. Dva Bf 108B-1 byly používány německým velvyslanectvím v Londýně. Tyto dva stroje byly v roce 1939 zabaveny a používány RAF. Po válce byl jeden Bf 108B-2 používán v Československu, dva v Polsku, po jednom v Dánsku a ve Švédsku. Asi 115 Nordů 1000 létalo ve Francii. Ovšem po celém světě létalo ještě dlouho po válce mnoho přeživších Taifunů, z nichž mnohé jsou dodnes v letuschopném stavu.

ATTENTION



UPOZORNĚNÍ



ACHTUNG



ATTENTION



注意



Carefully read instruction sheet before assembling. When you use glue or paint, do not use near open flame and use in well ventilated room. Keep out of reach of small children. Children must not be allowed to suck any part, or pull vinyl bag over the head.



Před započatím stavby si pečlivě prostudujte stavební návod. Při používání barev a lepidel pracujte v dobře větrané místnosti. Lepidla ani barvy nepoužívejte v blízkosti otevřeného ohně. Model není určen malým dětem, mohlo by dojít k požití drobných dílů.

INSTRUCTION SIGNS * INSTR. SYMBOLS * INSTRUKTION SINNBILDEN * SYMBOLES * 記号の説明

OPTIONAL
VOLBABEND
OHNOUTOPEN HOLE
VYVRTAT OTVORSYMMETRICAL ASSEMBLY
SYMETRICKÁ MONTÁŽNOTCH
ZÁREZREMOVE
ODRÍZNOUTAPPLY EDUARD MASK
AND PAINT
POUŽÍ EDUARDS MASK
NABARVIT

PARTS



DÍLY



TEILE



PIÈCES



部品

PLASTIC PARTS

A>

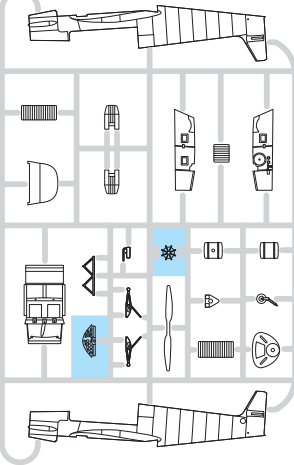

B>

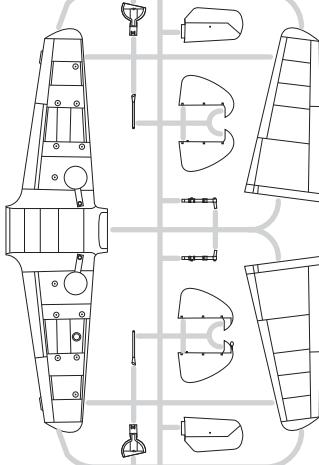

C>

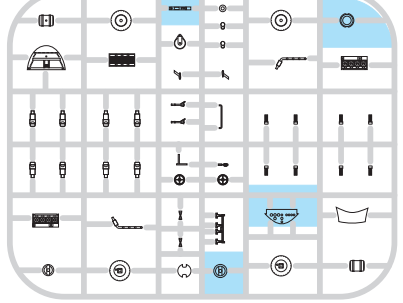

D>

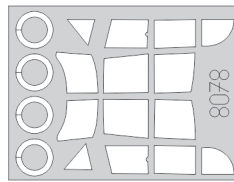
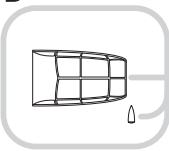
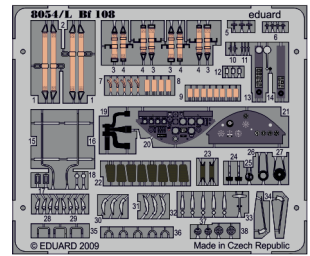
PE - PHOTO ETCHED
DETAIL PARTS

-Parts not for use. -Teile werden nicht verwendet. -Pièces à ne pas utiliser. -Tyto díly nepoužívejte při stavbě. - 使用しない部品

COLOURS



BARVY



FARBEN



PEINTURE



色

GSI Creas (GUNZE)			
AQUEOUS	Mr.COLOR		
H 2	C2	BLACK	
H 4	C4	YELLOW	
H 8	C8	SILVER	
H 11	C62	WHITE	
H 12	C33	FLAT BLACK	
H 33	C81	RUSSET	
H 34		CREAM YELLOW	
H 36	C15	DARK GREEN	RLM70
H 37	C43	WOOD BROWN	RLM79
H 47	C41	RED BROWN	
H 51		GRAY	
H 65	C18	BLACK GREEN	RLM70
H 66	C19	SANDY BROWN	RLM79
H 67	C115	LIGHT BLUE	RLM65

AQUEOUS	Mr.COLOR		
H 88	C36	DARK GRAY	RLM74
H 89	C37	GRAY	RLM75
H 70	C60	GRAY	RLM02
H 77	C137	TIRE BLACK	
H 303	C303	GREEN	
H 308	C308	GRAY	
H 406		CHOCOLATE BROWN	
H 413	C113	YELLOW	RLM04
H 417	C117	LIGHT BLUE	RLM76
H 420	C420	OLIVE GREEN	RLM80
Mr.METAL COLOR			
MC218		ALUMINIUM	
MC219		BRASS	
Mr.COLOR SUPER METALLIC			
SM06		CHROME SILVER	

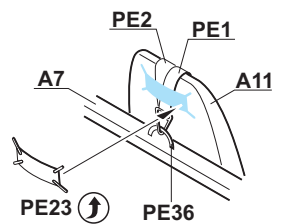
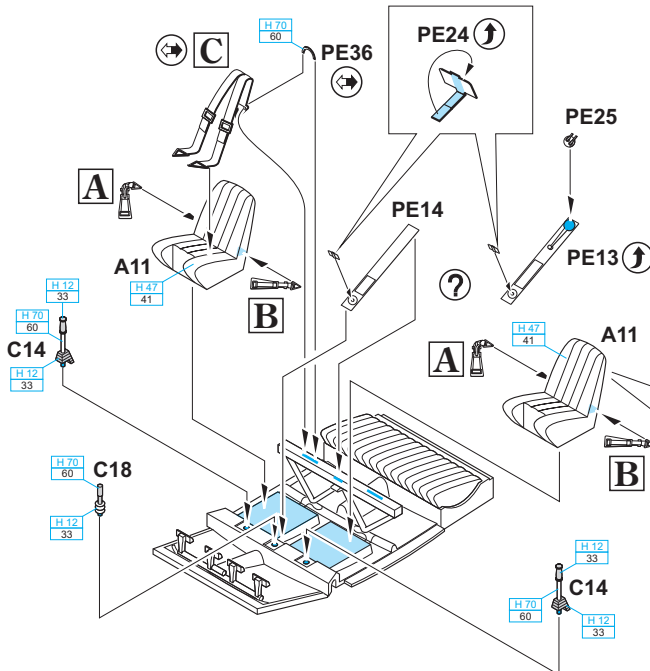
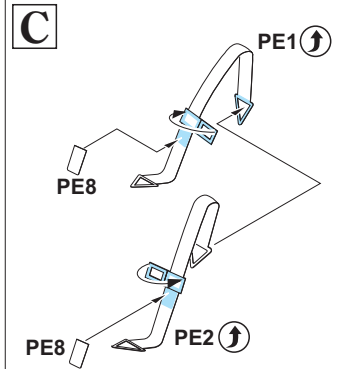
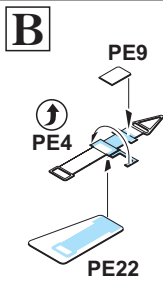
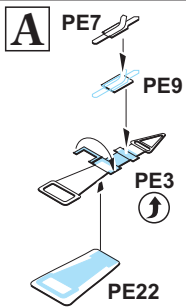
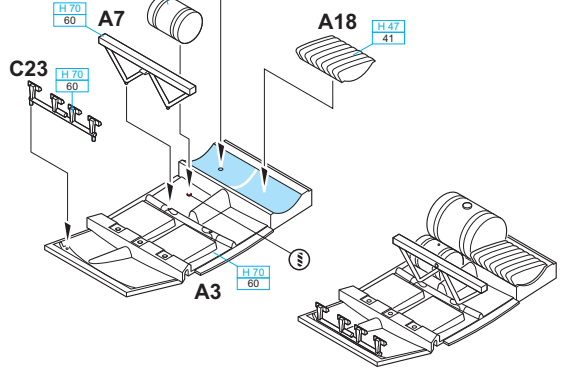
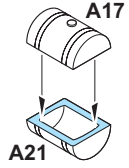
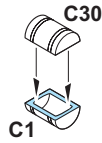
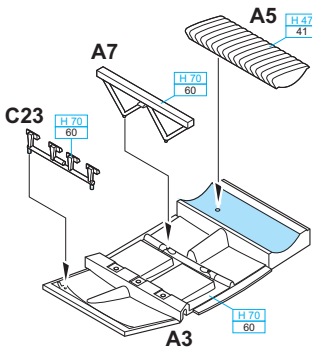

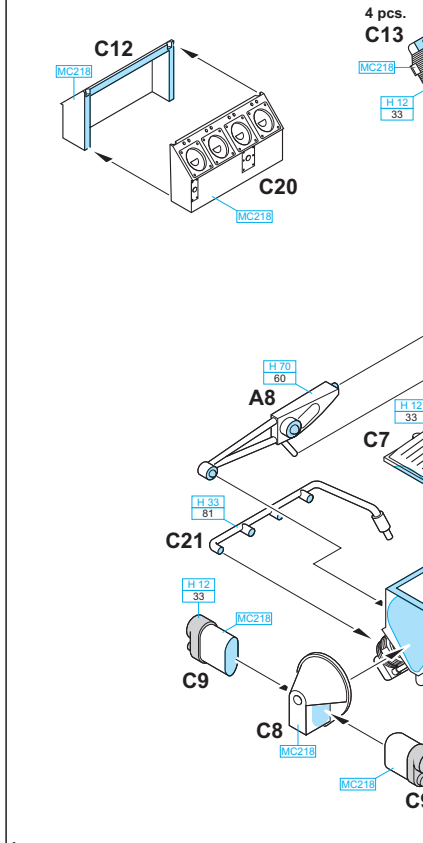
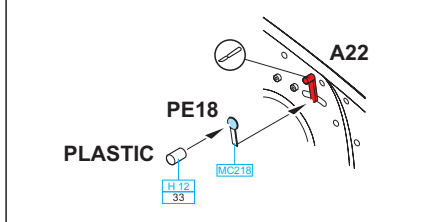
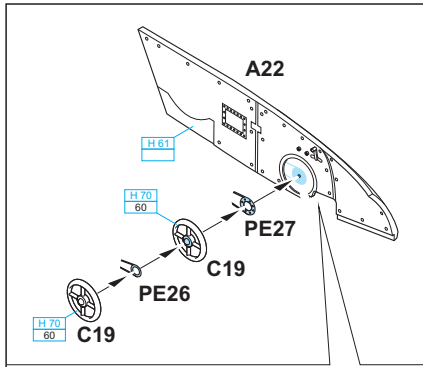

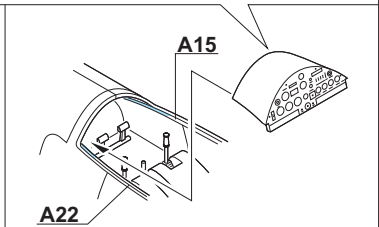
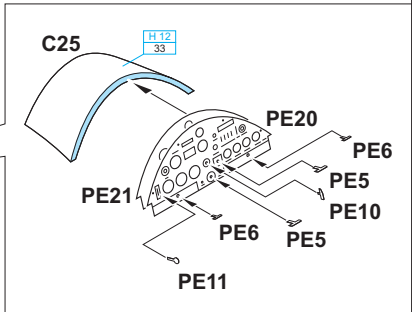
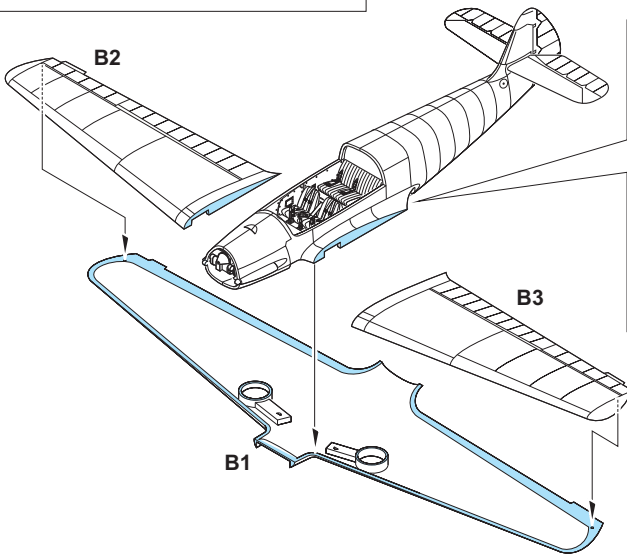
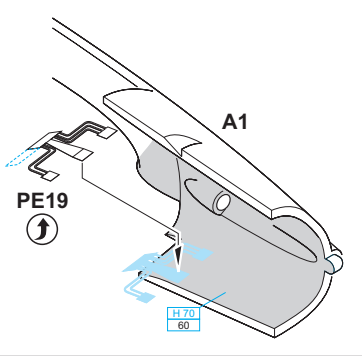
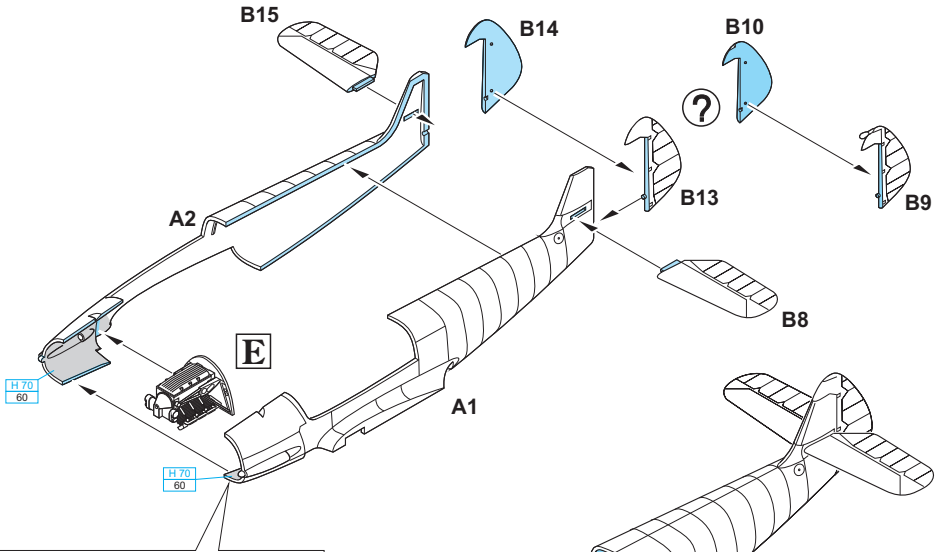

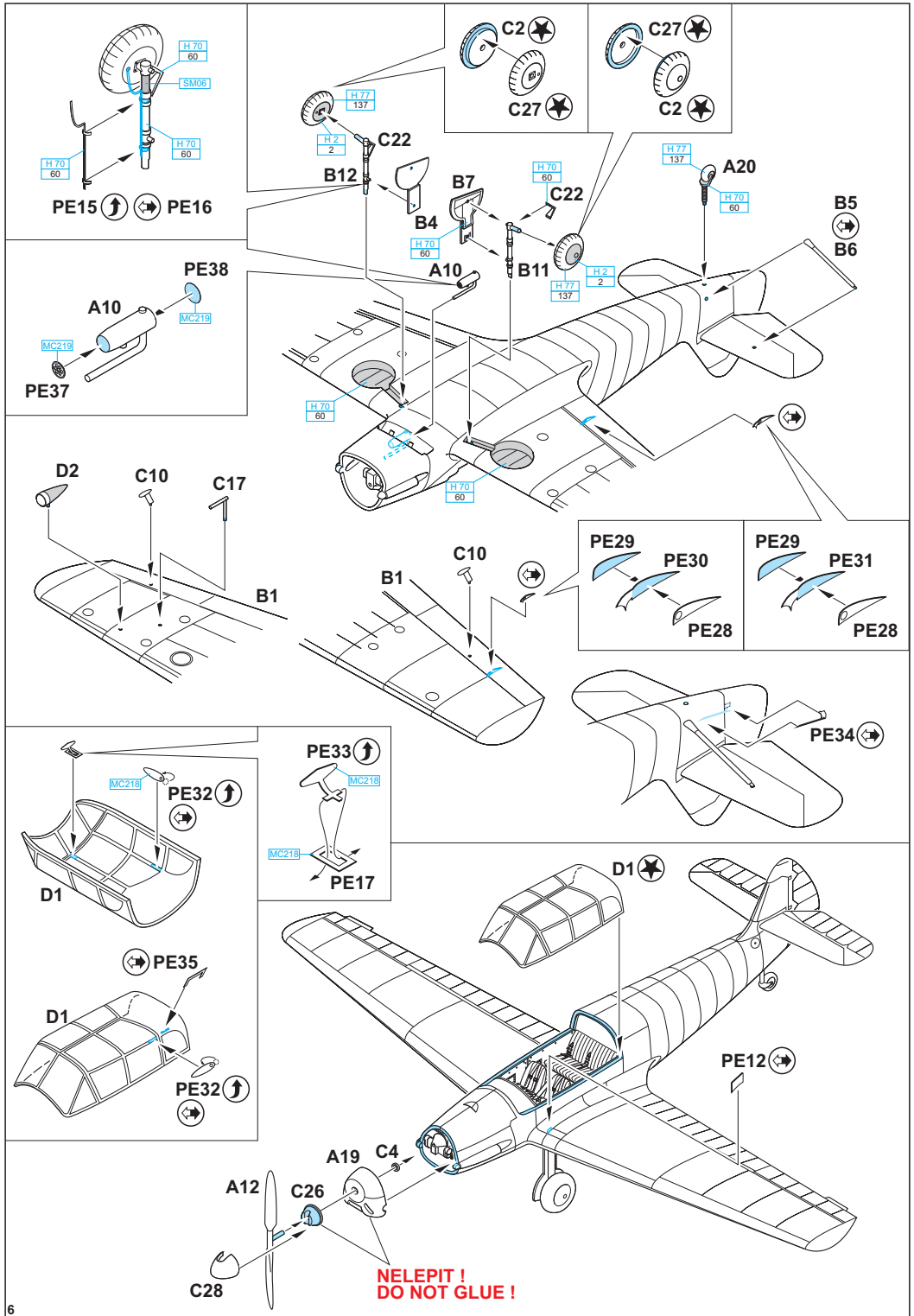

2 pcs.
C2

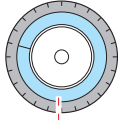

2 pcs.
C27

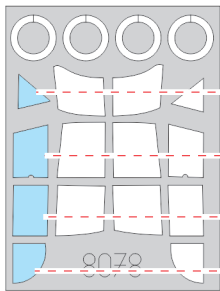
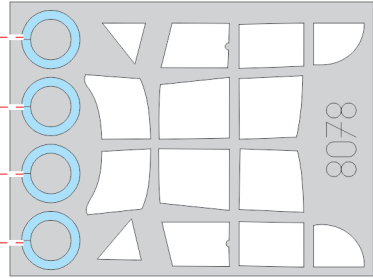
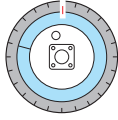

D1

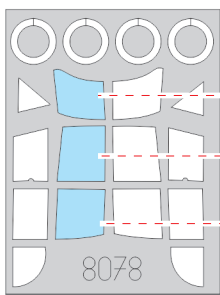
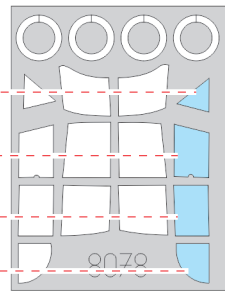
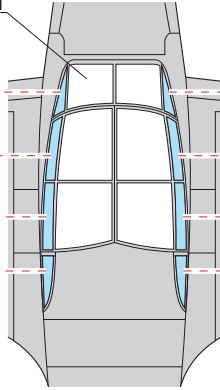

D1

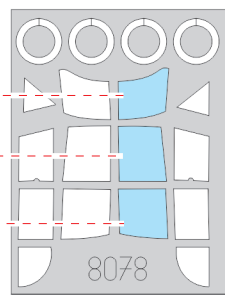
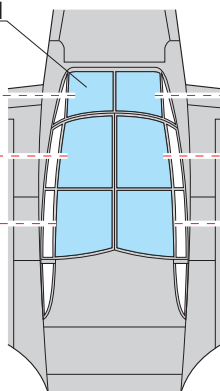

A Sonderkommando Blaich, Libya 1942

Sonderkommando Blaich, named after its Commander Hptm. Theo Blaich, was employed with He 111 in Libya during 1942. This liaison plane also belonged to their fleet. Taifun KG+EM was modified for service in tropical environment and also received a tropical camouflage comprised of a sand color camouflage scheme with green spots on the upper surfaces. The most interesting operation of this unit has been a successful bomb raid on the Allied fuel storage facility in For Lamy on January 22, 1942, in which a partial role also played this depicted plane.

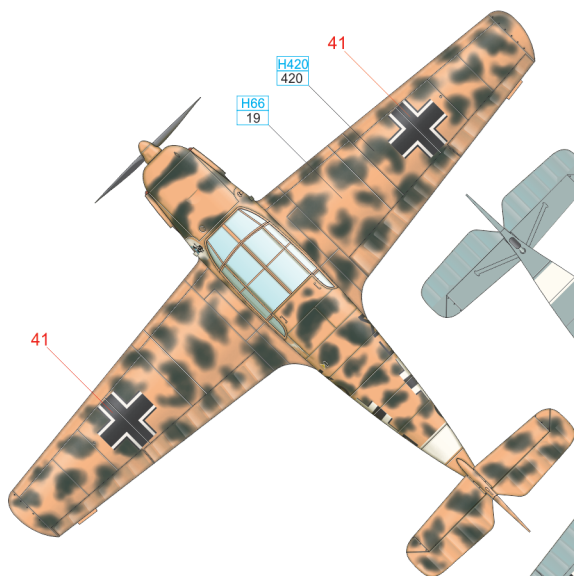
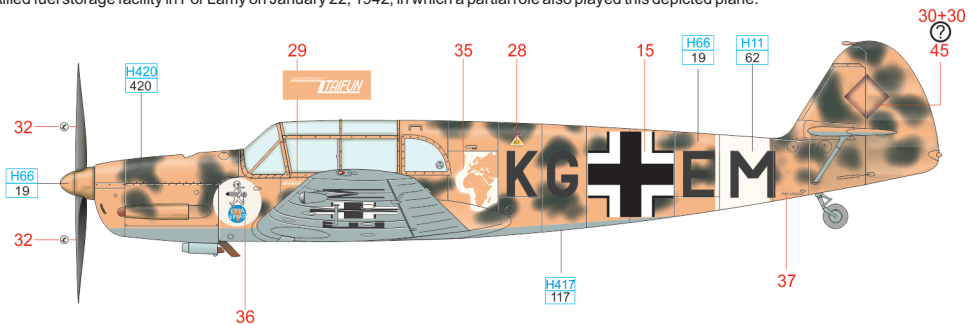

ČESKOU VERZI TEXTU NALEZNETE NA
www.eduard.com/s/8078

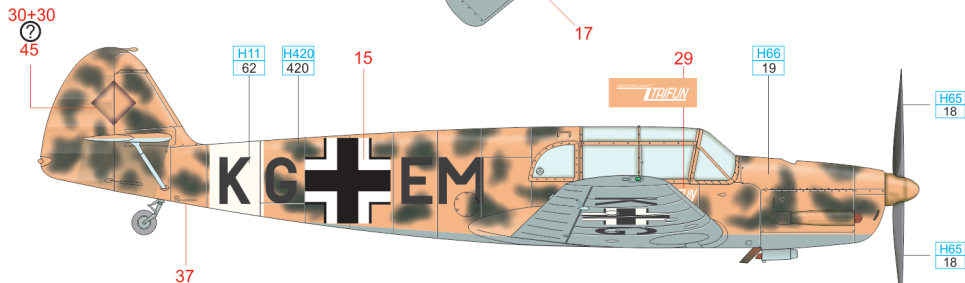
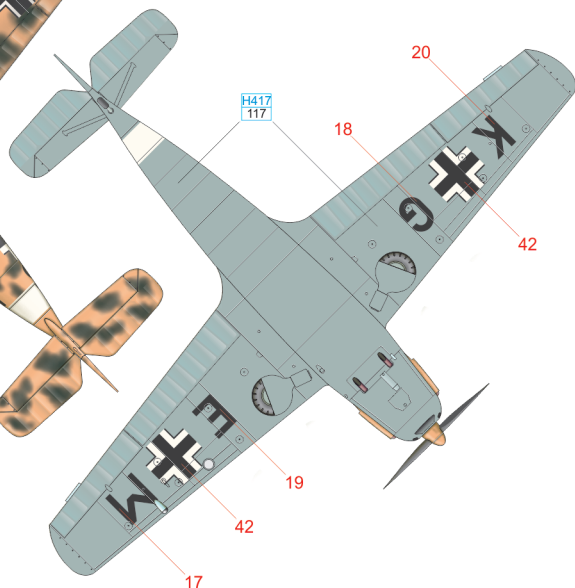

WHITE	H11 62	RLM 70	H65 18
RLM 76	H417 117	RLM 79	H66 19
		RLM 80	H420 420

C Germany, September, 1939

The German pre-war colors were used to camouflage this Taifun. Upper surfaces are painted RLM 61, RLM, 62 and RLM 63 colors, the undersides are RLM 65. The new camouflage was painted over the original factory colors thus the stenciling is not visible.

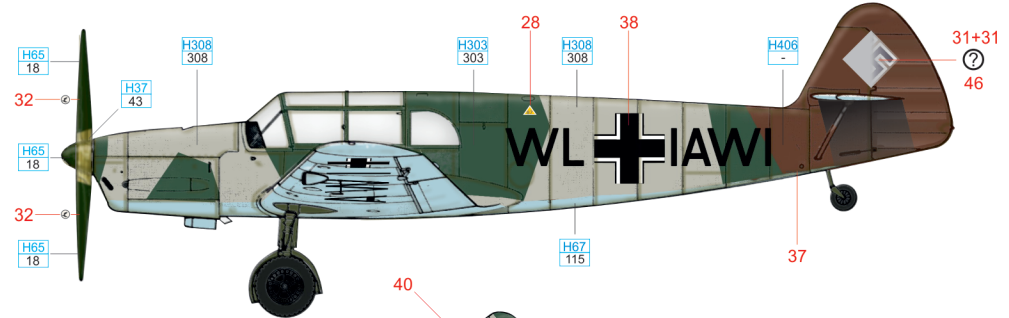

ČESKOU VERZI TEXTU NALEZNETE NA www.eduard.com/s/8078

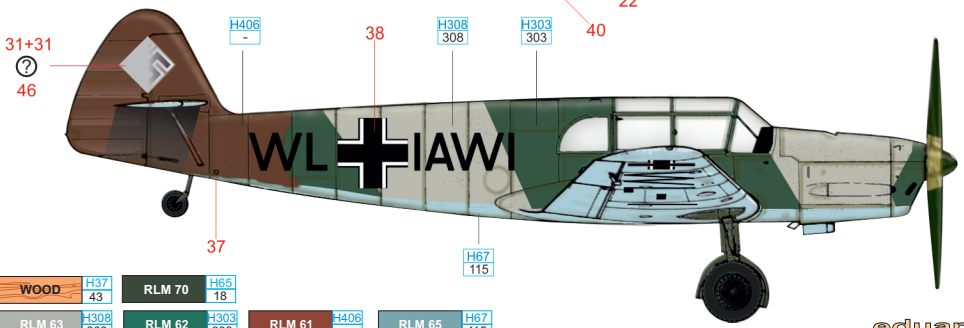
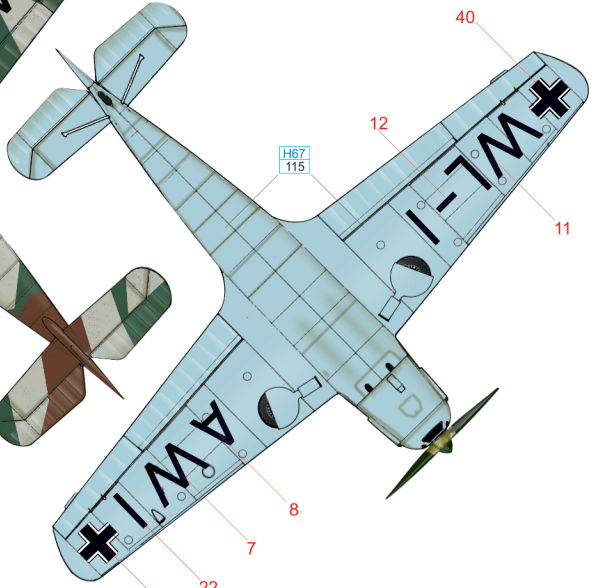
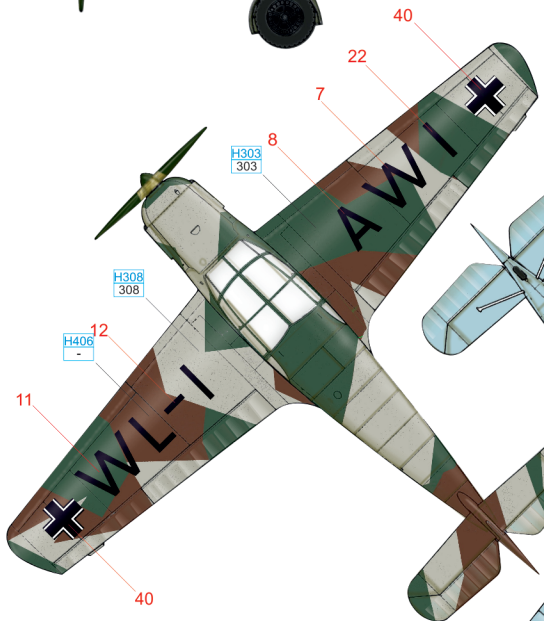

WOOD	H37 43	RLM 70	H65 18
RLM 63	H308 308	RLM 62	H303 303
	H406 -	RLM 61	H67 115
		RLM 65	H67 115

D Hungary, 1942 -1944

Very unusual camouflage scheme was painted on this aircraft. The RLM 74, 75 and 76 colors prescribed for fighter aircraft were used. This aircraft probably served in Hungary on on the Eastern front. The code letters ZS are either oversprayed or scraped off.

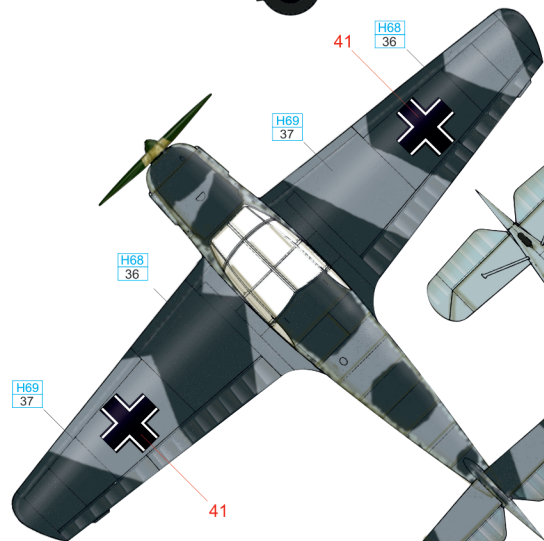
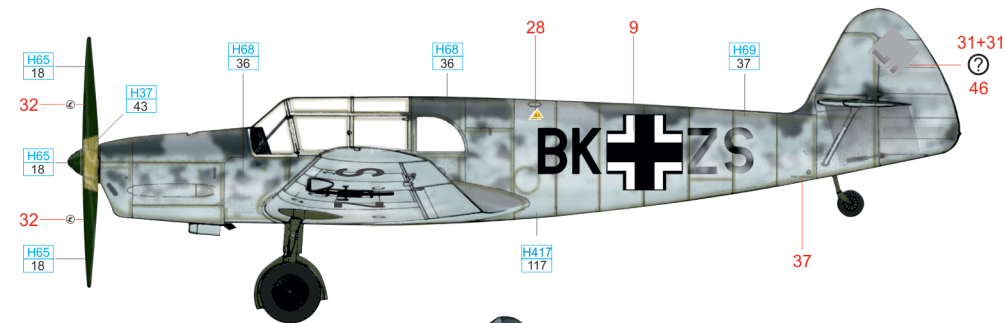

ČESKOU VERZI TEXTU NALEZNETE NA
www.eduard.com/s/8078

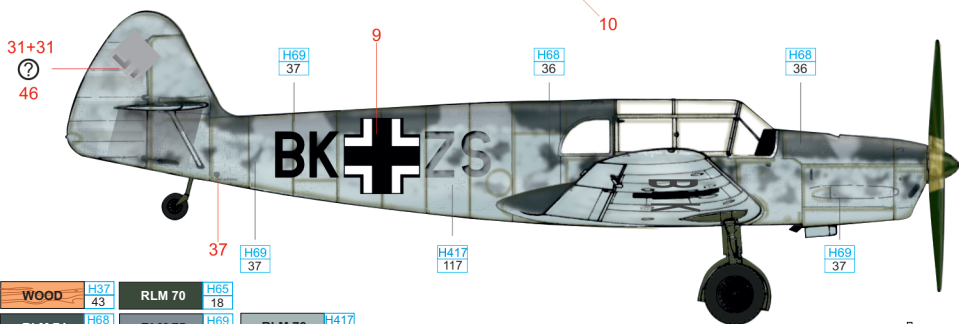
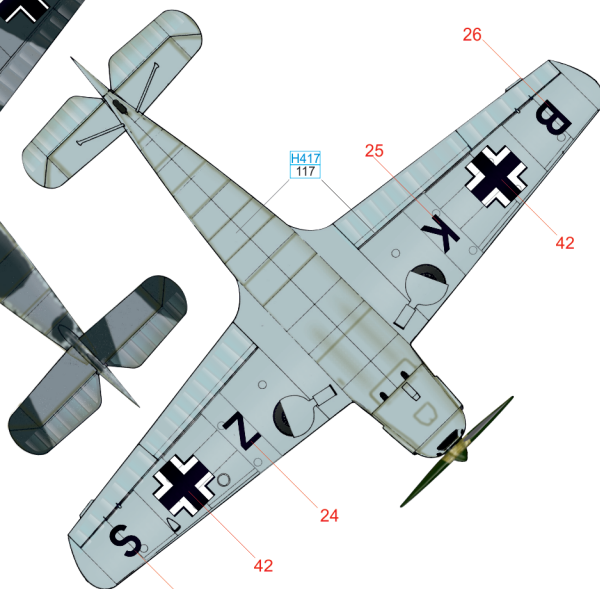

WOOD	H37 43	RLM 70	H65 18
RLM 74	H68 36	RLM 75	H69 37
		RLM 76	H417 117

E Eastern Front, 1942 – 1943

The camouflage scheme consists of RLM 70 and 71 on upper surfaces and RLM 65 on lower surfaces. The upper surfaces are overpainted with white splotches. The white is sprayed over the other parts of national insignia.

