

GERMAN V-1 FIESELER FI 103 RE-4 PILOTED FLYING BOMB 1/35 SCALE 德軍V-1 FI103 RE-4載人飛彈(單座)



By 1942 the Luftwaffe could no longer bomb England due to RAF air superiority, yet the RAF was able to bomb German cities at will. This led the Germans to develop their Vergeltungswaffe, or vengeance weapons. The first of these was the Fieseler Fi-103, a small jet powered flying bomb developed in 1943 and ready for service in mid-1944. The V-1 was normally launched by a steam catapult from a fixed firing ramp, but as the launch sites were overrun by ground forces, some were air launched from Heinkel He111 bombers. The V-1 carried an 850kg warhead to a maximum range of 250 kilometers at a speed of 630 km/h. The first weapons were launched against London in June 1944, a few days after the Allied D-Day landings in France. Over 10,500 V-1's were launched during the war, but of these only about 2,500 hit their targets, the rest were intercepted or crashed due to mechanical failure. The Japanese were given plans of the V-1 and they built a piloted version, the Kawanishi Baika, but this was not ready for use by war's end.

Information by Philip Greenwood

Aufgrund der britischen Luftüberlegenheit konnte die deutsche Luftwaffe ab 1942 England kaum noch bombardieren, während im Gegenzug die RAF über Deutschland ziemlich freie Hand hatte. Dieses brachte die Ingenieure 1943 auf die Idee zur Entwicklung der Fieseler Fi-103, einer relativ kleinen Düsenangetriebenen Flügelbombe, welche dann ab Mitte 1944 eingesetzt wurde. Der als V-1 (V=Vergeltungswaffe) bekannte Marschflugkörper wurde von Dampfgetriebenen Katapulten gestartet. Nachdem diese von alliierten Bodentruppen überrannt wurden, benutzte man HE-111 Bomber als „Starthilfe“. Die V-1 trug einen 850 kg schweren Sprengkopf mit knapp 600 km/h bis zu 250 km weit. Im Juni 1944, kurz nach den Landungen in der Normandie, gingen die ersten V-1 in London nieder. Von den hergestellten 10500 Stück trafen ca. 2500 das jeweils vorgegebene Zielgebiet, welches ein Radius von 12 km hatte. Nachdem die Japaner die Pläne der V-1 erhalten hatten, bauten sie eine eigene bemannte Version, welche jedoch bis Kriegsende nicht einsatzbereit war.

© Translation Michael Knoblich Academy Europe

V-1(Fi103)飛彈是世界上第一種巡航式導彈。德軍將V-1飛彈發射陣地集中建在朝向英國的法國海岸。1944年6月13日德軍V-1飛彈發射部隊(第155高炮團)開始向英國本土發動了攻擊。至同年9月4日,德軍向英國東南部地區共發射了8600多枚V-1導彈,其中射向倫敦的約5000枚,但真正打到倫敦的不到一半。而且大多數飛彈造成的傷亡不大,只有少數飛彈打到了人口密集區才造成較嚴重傷亡和損失。直至1945年的1月初,對英國目標發射的飛彈總數達10,500枚左右。約有175枚V-1被改裝成載一名飛行員的飛彈,它的代號為“賴興貝格”。這種飛彈是準備用一架亨克爾He111轟炸機載到空中後再從其下部發射出去。“賴興貝格”飛彈駕駛員在將飛彈對準目標後即跳傘脫離飛彈。但是,儘管進行過多次試驗和訓練,有人駕駛的V-1飛彈始終未用於實戰。

ILLUSTRATION 圖示說明:

CORRECT METHOD FOR APPLYING DECALS : HINWEISE ZUM ANBRINGEN DER DECALS :

正確使用水貼紙的方法:

1. Clean model parts surface with wet cloth. Entsprechende Stellen am Modell feucht reinigen.
將需要貼上水貼之部位表面擦乾淨。
2. Cut out the decal parts and dip them in cold water for 15 ~20 seconds. Decal ausschneiden und für 15-20 Sek. ins Wasser legen.
將所需之貼紙剪下泡在清水裏約15至20秒。
3. Place it on correct position of the model kit. Decal an der richtigen Stelle auflegen.
將濕透之貼紙取出置放於正確之位置旁。
4. Slide off the decal from the base paper on to the model kit surface with a cotton stick. Decal mit Wattestäbchen festhalten und Papier darunter wegziehen.
用棉花棒輕推貼紙表面使其從底紙滑出至模型表面之正確位置。
5. When decal get dry then complete. Decal mit Papiertuch andrücken und trocknen.
待其自然乾透後即完成。

ICON INSTUCTION: 圖標說明:



Open Hole
Loch bohren
鑽孔



Remove
Abtrennen
切除



2 Sets needed
Vorgang wiederholen
同樣的製作二組



Bend
Biegen
曲折



Optional
Auswahl
可以選擇採用



Apply Decal
Decal anbringen
貼上水貼紙



Instant Glue For Metal
Sekundenkleber verwenden
瞬間接著劑,金屬用



Fill Hole
Verspachteln
把孔填平



Do not cement
Nicht kleben
不用粘合

COLOR SUGGESTION: FARBTABELLE: 塗裝指引:

Color 塗料表	Gunze Sangyo	Hobby Color	Humbrol	Tamiya
German Gray Deutsch Grau 德國灰	H-32	C-40	92	XF-63
Dark Green Dunkelgrün 深綠色	H-36	C-17	30	XF-61
Light Blue Hell Blau 淺藍色	H-67	/	/	XF-23or AS-5
Field Grey Feldgrau 原野灰	H-48	C-52	/	XF-65
Burnt Iron Metall brüniert 燒鐵色	H-76	C-61	/	/
Tire Black Reifenschwarz 輪胎黑	H-77	C-137	85	/
Steel Stahl 黑鐵色	H-18	C-28	53	/
Semi-Gloss Black Schwarz Seidenmatt 半光黑色	/	C-82	/	/
Silver Silber 銀色	H-8	J-8	11	X-11
Neutral Grey Neutralen Grau 中灰色	H-53	C-13	/	XF-53
Flat Brown Matt Braun 消光啡色	H-17	/	62	XF-10
Aluminium Aluminium 鋁色	/	/	56	XF-16
Buff Büffelleder 淺黃色	/	/	/	XF-57

READ BEFORE ASSEMBLING: VOR ZUSAMMENBAU LESEN: 組裝必讀:

- Carefully Study instruction before assembling. Anleitung studieren und verständlich machen. 組裝前請閱讀清楚製作指引。
- Keep plastic model glue and tools away from children. Kleber, Farben, Werkzeuge und Plastiktüten von Kindern fernhalten. 膠水,油漆及工具勿讓小孩接觸。
- Do not use cement or paint near open flame or sparks. Kleber/Farbe nicht in Nähe von offenen Flammen. 膠水及油漆勿接觸火種。
- Do not work in closed room. Nur in ausreichend belüfteten Räumen arbeiten. 勿在密封地方製作模型。

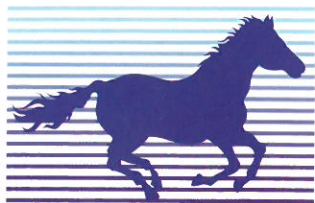

BRONCO

Bronco models

Copyright©2008

Made in China

中國製造



No use parts
不要部件

ⓑ x1

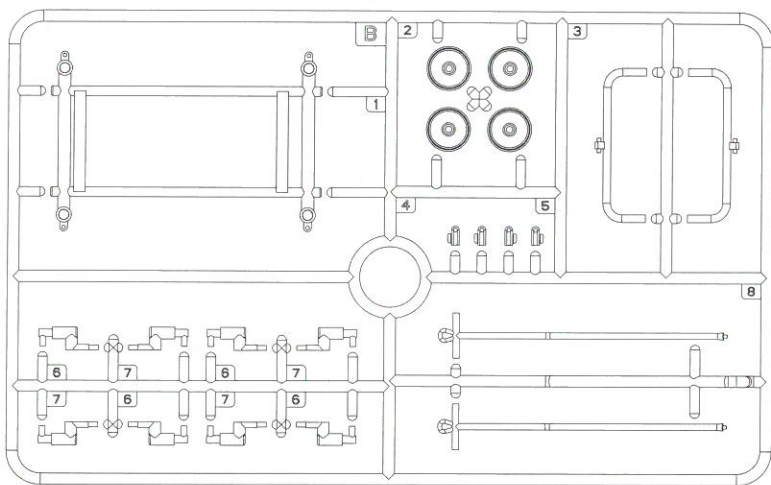

ⓒ x1

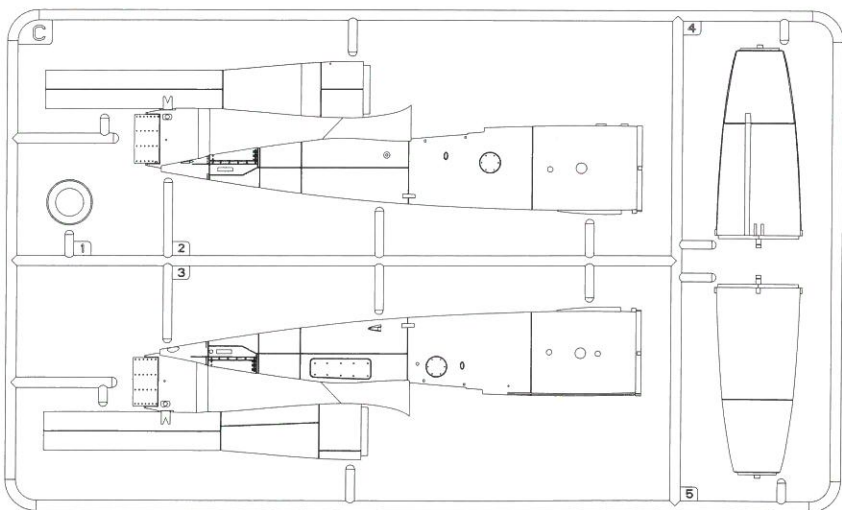

Ⓕ x1

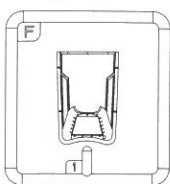

ⓓ x1

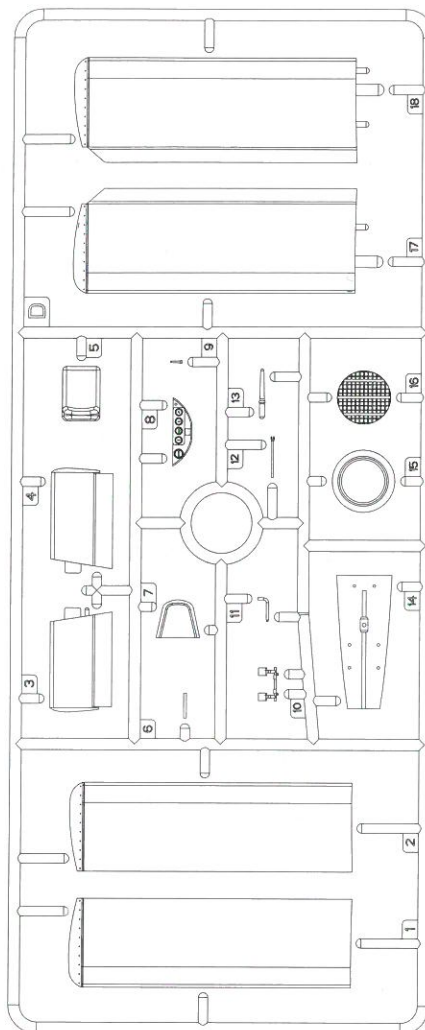

Ⓟ x1

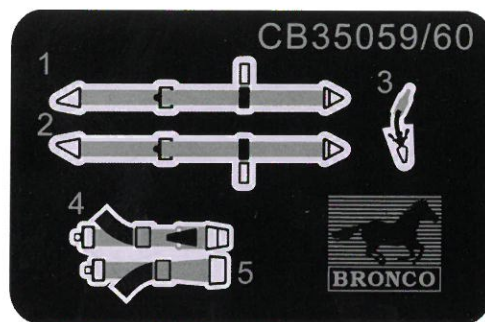
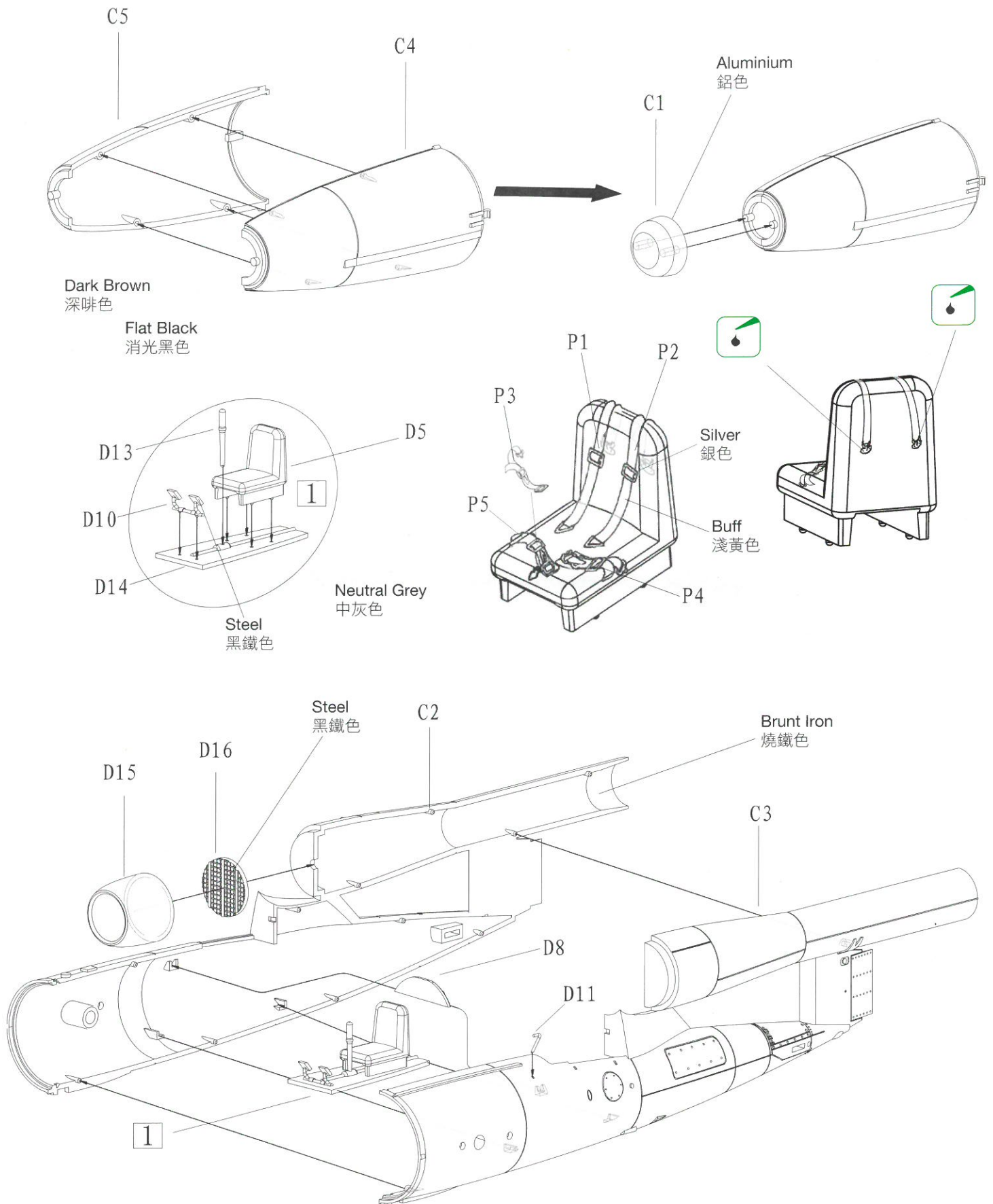

ILLUSTRATION 圖示說明:



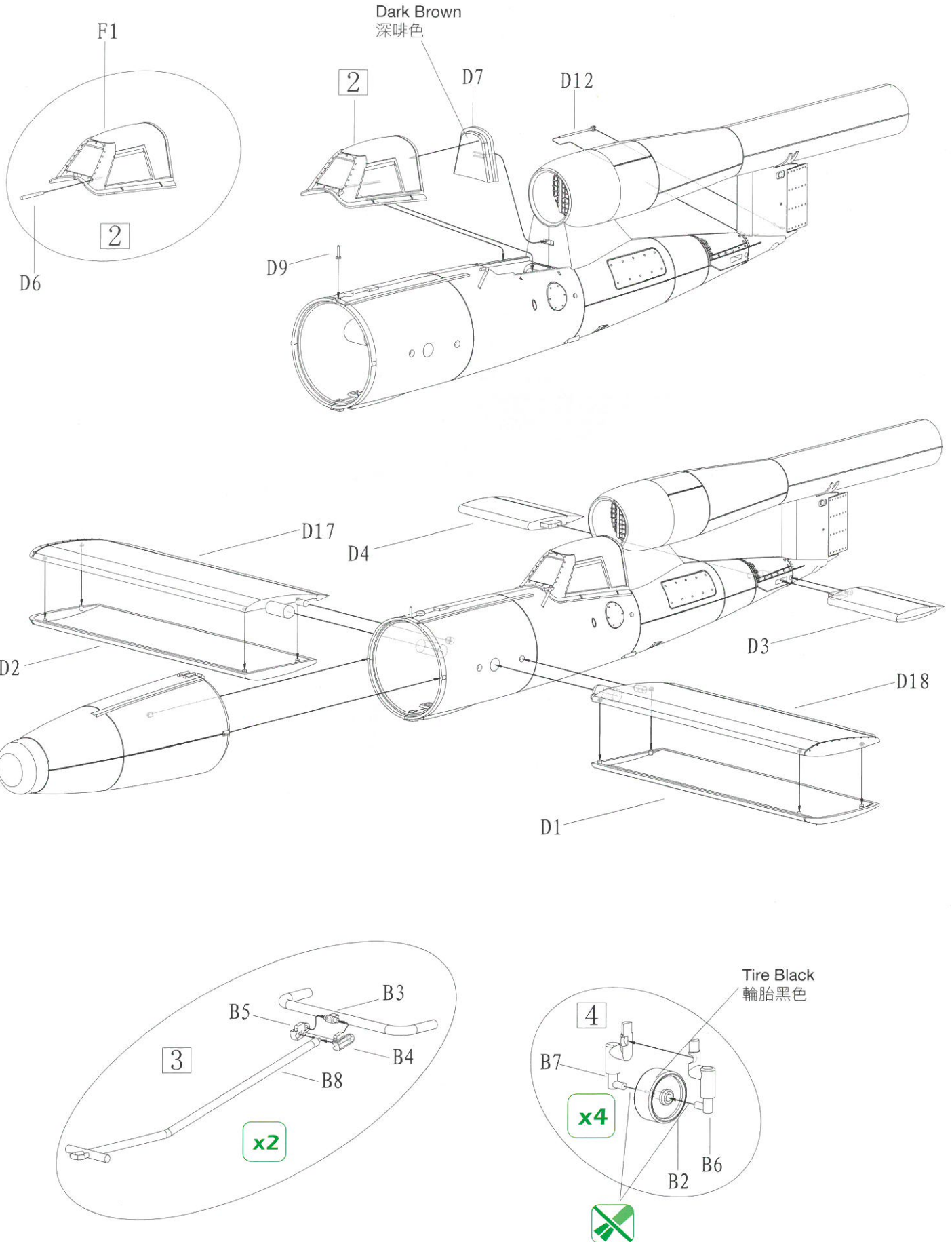
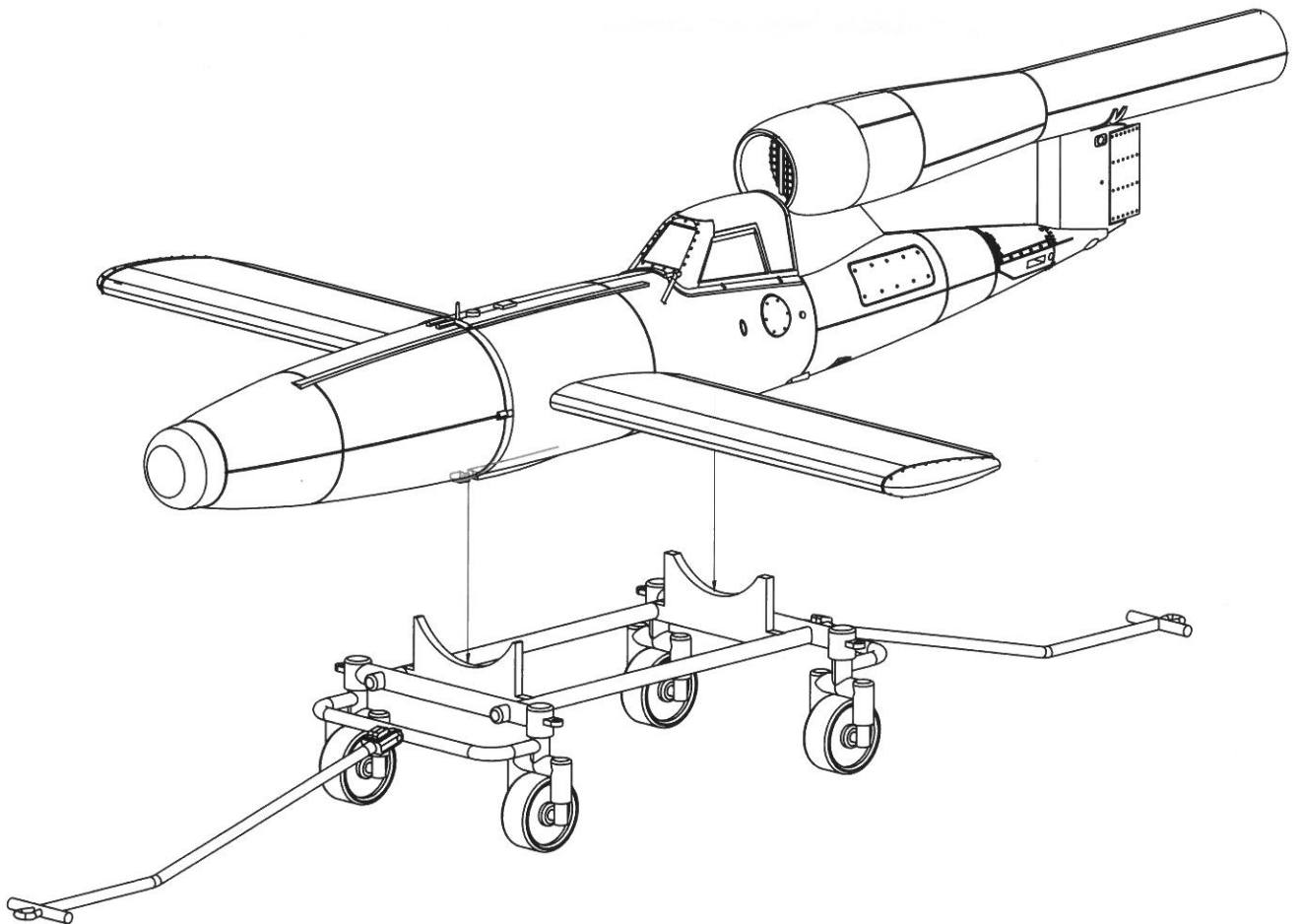
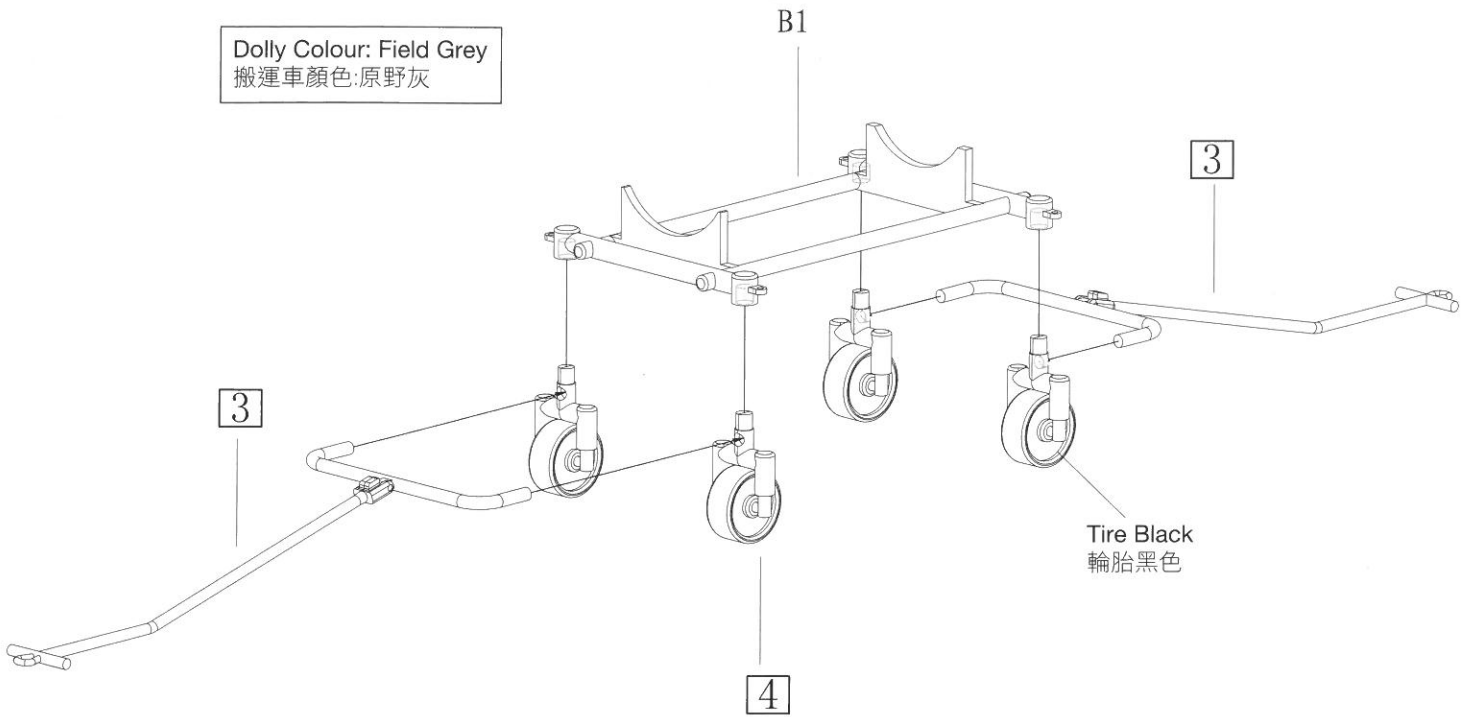
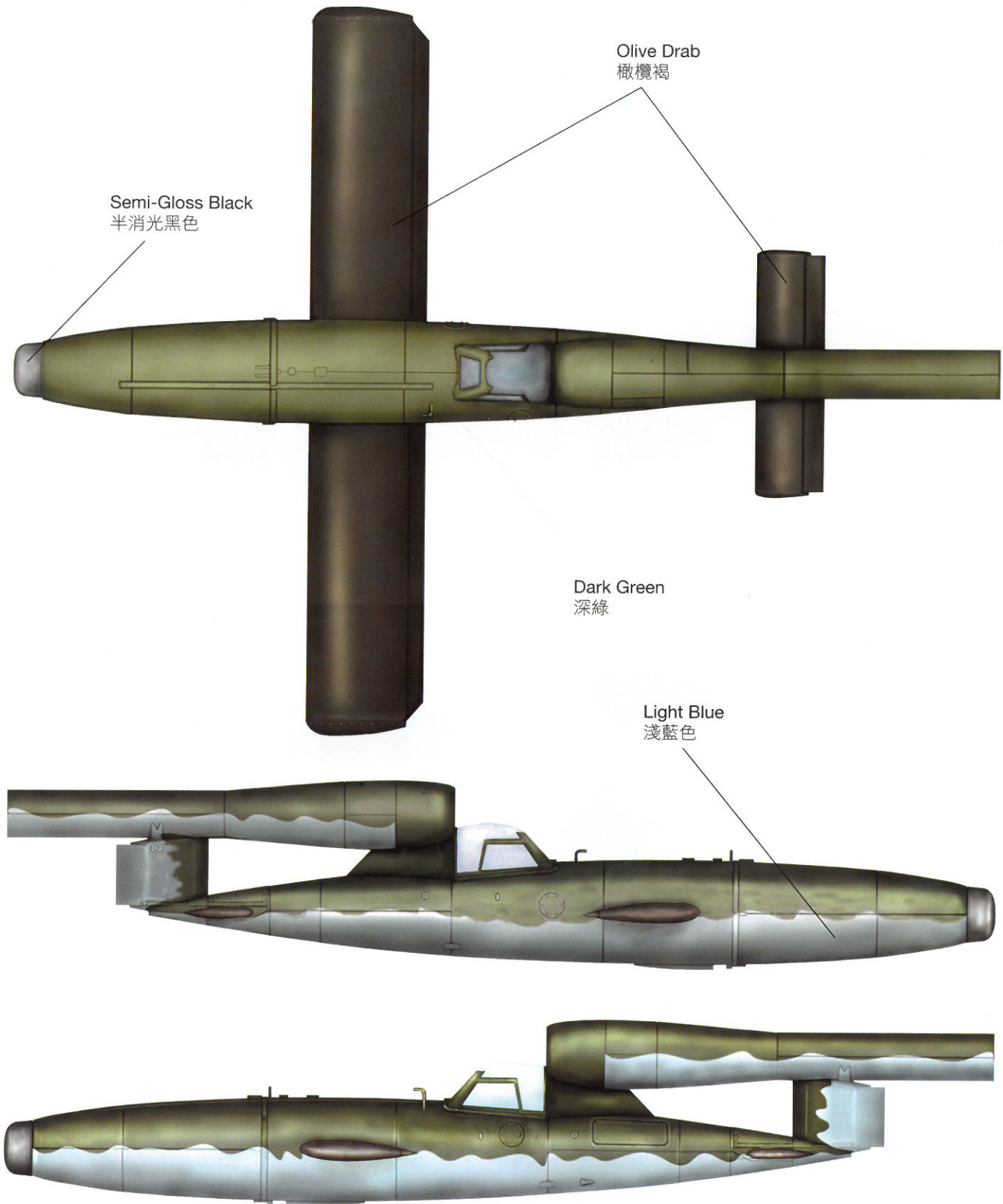

ILLUSTRATION 圖示說明:

Dolly Colour: Field Grey
搬運車顏色:原野灰



Oprion 1 -V1 Fi103 Re-4 (Planned Camouflage)
計畫中的迷彩



Camouflage Scheme: Upper Surface(Dark Green)
Under Surface(Light Blue)
迷彩顏色: 上半部(深綠色);下半部(淺藍色)

DECAL & COLOUR GUIDE 水貼及塗色指示:

Option 2 -V1 Fi103 Re-4 Captured by British Troops at Rechlin, Germany, May., 1945

1945年5月在德國雷希林地區被英軍擄獲之V1 Fi103 Re 單座載人飛彈

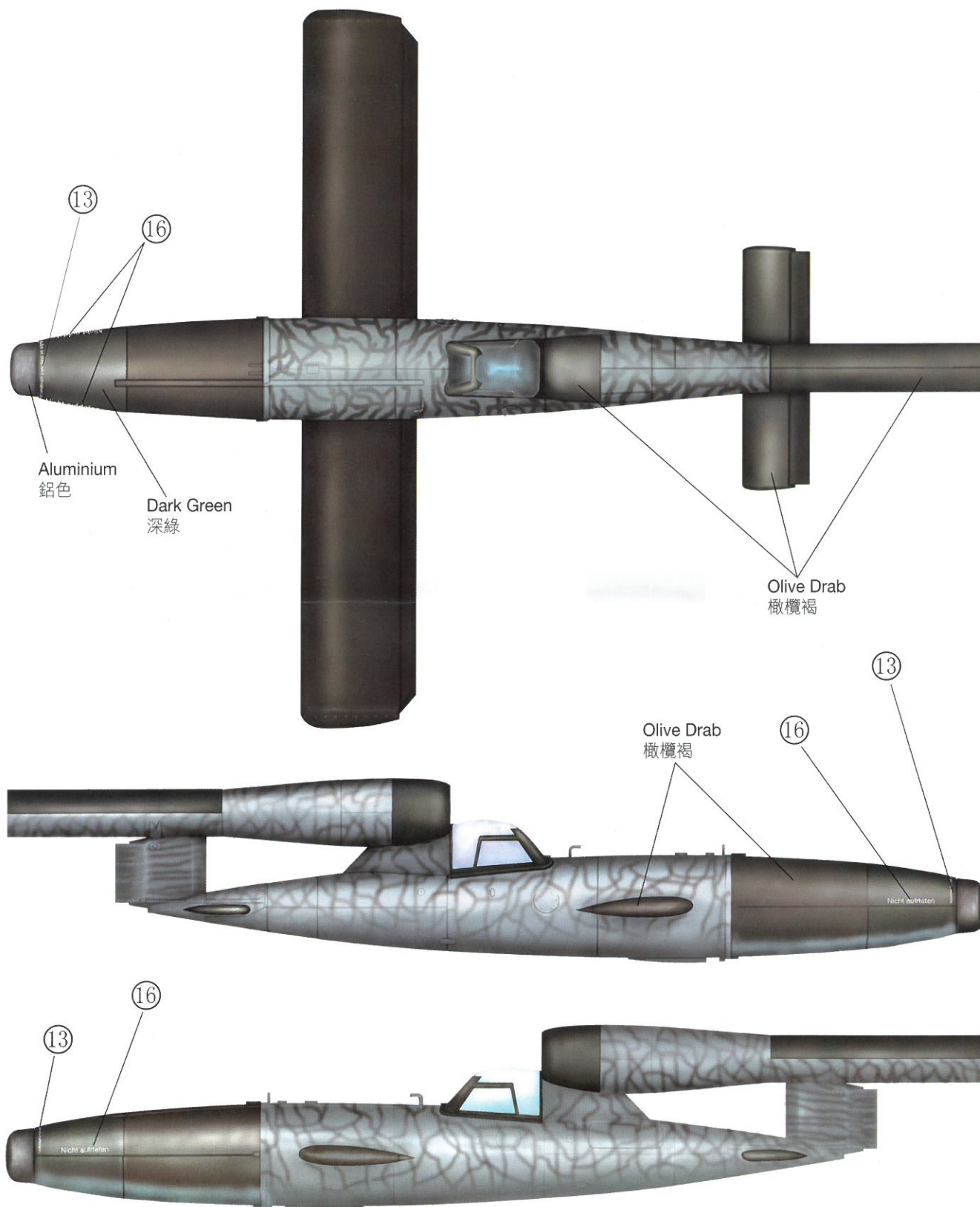

Camouflage Scheme: Upper Surface-Light Blue with Bark Green Stripe
Under Surface-Light Blue

迷彩顏色: 上半部(淺藍色外加深綠色條狀紋); 下半部(淺藍色)