

## NÁVOD / INSTRUCTION

# Fiat G.55A "Post War Service"

GB

Three Italian companies had test flown their new modern fighter prototypes during 1942. Except Aermacchi C.205 and Reggiane Re 2005 it was the Fiat G.55. All three aircraft were powered by DB 605 engines and later by license built version RA 1050 Tifone. All three aircraft were accepted by Regia Aeronautica but Fiat G.55 was addressed as the main fighter aircraft. Even German Luftwaffe was interested in new Fiat fighter.

The first prototype, serial number MM491, took off on 30th April 1942. Later, two additional prototypes were built and together with the initial series of 12 preproduction aircraft (ser. no. MM91053 to 91064) were designated Serie 1 Sotoserie 0. The armament of these aircraft consisted of one 20mm cannon Mauser MG 151/20 firing through the hollow propeller's shaft and four nose mounted 12.7mm SAFAT machine guns. The final armament of subsequent aircraft of both Sotoserie 0 and Serie 1, consisted of two wing mounted cannons and two machine guns mounted above the engine. Independently from the armament changes particular aircraft were produced with two different types of fin.

The first aircraft were deployed within Regia Aeronautica. New aircraft were successful, particularly when fighting with P-38 Lightnings. When the Armistice was signed Centaures were seized for Luftwaffe during the German occupation of Italy. Also, Fiat Company in Torino was seized by Wehrmacht. The earlier halted production was later started again and several aircraft were handed over to Luftwaffe. Eventually, the rest of the produced aircraft was passed on to Italian National Republic's Air Force (Aeronautica Nazionale Repubblicana). Within ANR these aircraft participated in heavy fights against allied bombers with fighter escorts. Initially, Centauros had been assigned to the Squadriglie Complementare Caccia „Montefusco“ (later to revere fallen commander renamed „Montefusco-Bonet“). Later on Centauros were also assigned to 2° Gruppo Caccia that went through heavy fights and later was re-equipped by Bf 109s. The rest of the Fiat G.55s was concentrated with 1° Gruppo Caccia. This unit fought successfully, but with heavy losses, against the overwhelming numbers of American and British aircraft until August of 1944. On 10th August 1944 the test pilot S. Agostini deserted to Allied territory in one Fiat G.55. He had another passenger in his cockpit, British intelligence agent F. Gentile. This action had intensified the tense relation between Germany and Italy. Subsequently on 25th August, during Phoenix operation Germans occupied Italian airfields and disarmed ANR. 1° Gruppo Caccia's Fiat G.55s stationed at Vicenza airfield were stripped off propellers and eventually scraped as so the new machines in Torino. 107 Fiat G.55s were produced during the war. The production was started again after the war in 1946. Both Fiat G.55A (single seater) and G.55B (double seater) were produced for Italian, Argentinean, Egyptian and Syrian air forces. Both Egyptian and Syrian aircraft participated in fights against new Israel state.

Wingspan: 11.85 m, Length: 9.37 m, Max Speed: 620 km/h at 8000m, Climb to 7000m: 8 min and 34s, Service Ceiling: 13000 m, Range: 1050 km

CZ

V průběhu roku 1942 zalétaly tři italské firmy prototypy moderních stíhaček. Kromě Aermacchi C.205 a Reggiane Re 2005 šlo o Fiat G.55 Centauro. Všechny tři byly poháněny motorem DB 605 nebo později jeho licenční verzí RA 1050 Tifone. Do výzbroje byly vybrány všechny tři stroje, ale Fiat G.55 byl vybrán jako základní stíhačka Regia Aeronautica. Mimo to o nový Fiat projevila zájem i Luftwaffe.

První prototyp MM491 vzletl 30. dubna 1942, posléze byly postaveny další dva prototypy. Ty, stejně jako prvních dvanáct kusů z první výrobní série označované Serie 1 Sotoserie 0 (MM91053-91064) měly výzbroj složenou z kanónu Mauser MG 151/20 ráže 20 mm v ose vrtule a čtyř kulometů SAFAT ráže 12,7 mm v přidi. Další stroje jak Sotoserie 0, tak Serie 1 nesly definitivní výzbroj složenou ze dvou kanónů v křídle a dvou kulometů nad motorem. Nezávisle na výzbroji dostávaly jednotlivé kusy dva typy svislých ocasních ploch.

Prvé stroje byly nasazeny v rámci útvarů Regia Aeronautica. Nové stíhačky si úspěšně vedly hlavně v bojích proti stíhačkám P-38 Lightning. Po uzavření příměří se spojenci byly Centaury zabaveny pro Luftwaffe při obsazení Itálie Němci. Stejně tak byl obsazen německými vojsky závod Fiat v Turíně. Zastavená výroba byla později obnovena, několik kusů převzala Luftwaffe, ale nakonec veškeré vyrobené Fiaty G.55 byly předány letectvu Italské Národní Republiky (Aeronautica Nazionale Repubblicana). V řadách ANR se účastnily těžkých bojů proti bombardovacím svazům doprovázených stíhačkami. Centaury byly nejprve nasazeny u Squadriglie Complementare Caccia „Montefusco“ (na památku velitele padlého v boji byla později přejmenována na „Montefusco-Bonet“). Později byly dodány Centaury také 2° Gruppo Caccia, které prošlo těžkými boji a posléze bylo přezbrojeno na Bf 109. Zbýlé Fiaty G.55 byly soustředěny u 1° Gruppo Caccia. Tato jednotka bojovala úspěšně, ale také s poměrně vysokými ztrátami proti přesile amerických i britských letounů až do srpna 1944. 10. srpna 1944 uletěl ke spojencům s Fiatem G.55 zkušební pilot S. Agostini. V kabině s ním přeletěl ke spojencům i agent britské rozvědky F. Gentile. Úlet zkomplikoval napjaté vztahy mezi Němci a Italy. Němci při akci Phoenix 25.8. 1944 obsadili italská letiště a odzbrojili letectvo ANR. Fiatům G.55 1° Gruppo Caccia byly na letišti Vicenza odmontovány vrtule a později byly zničeny, stejně jako nové stroje v Turíně. Během války bylo vyrobeno 107 kusů Fiatu G.55. Po válce byla v roce 1946 výroba obnovena a pro Italské, Argentinské, Egyptské a Syrské letectvo byly vyráběny jak jednomístné Fiaty G.55A, tak dvómístné Fiaty G.55B. Egyptské a Syrské letouny zasáhly do bojů proti státu Izrael.

Rozpětí: 11,85 m, délka: 9,37 m, max. rychlost: 620 km/h ve výšce 8 000 m, výstup do 7 000 m: 8 min a 34 s, dostup: 13 000 m, dolet: 1 050 km

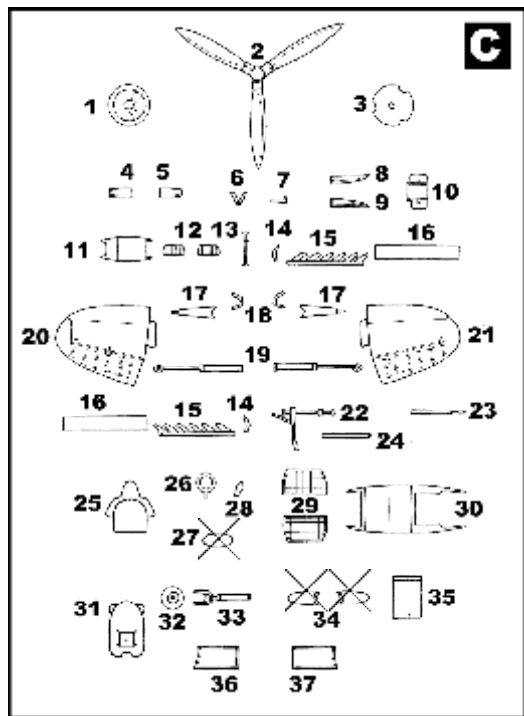
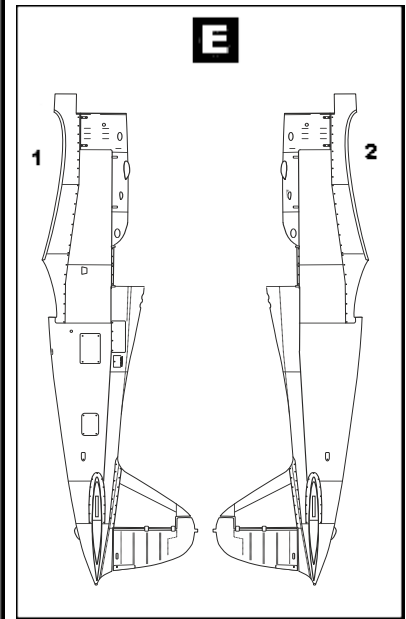
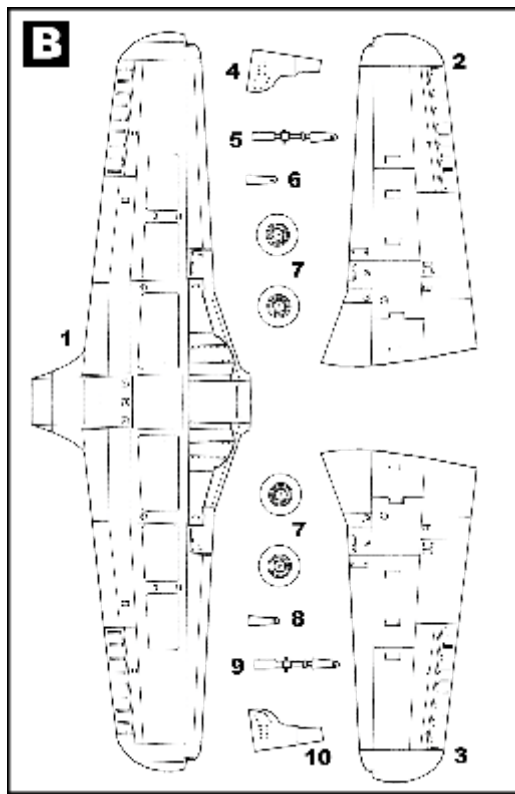
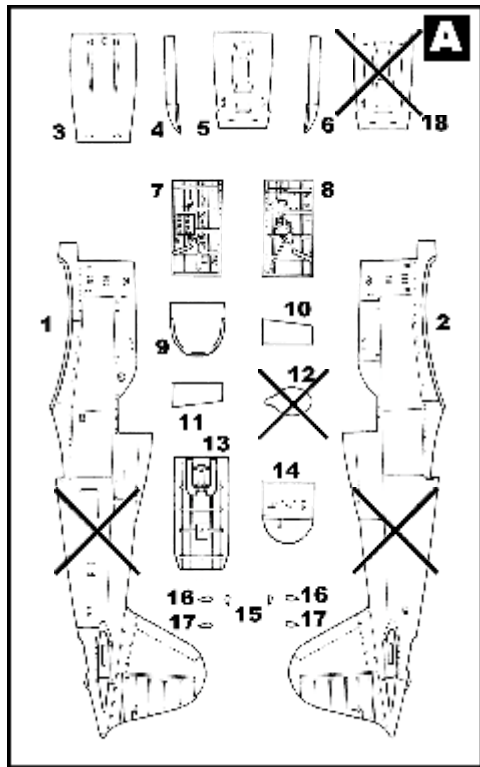
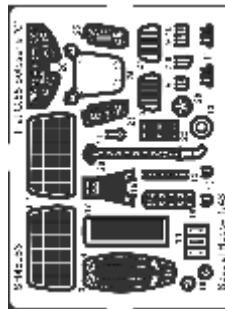
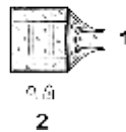

PHOTO-ETCHED PARTS (PP)



CLEAR PARTS (CP)



FILM (F)



POLYURETHAN PARTS (PUR)

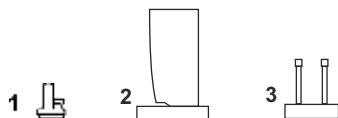

Volba  
Optional  
Nachleihen  
Option



Odstřezit  
Remove  
Entfernen  
Detacher



Lepidlo na kov  
Glue for metal  
Metallkleber  
Colle a metal



Občitek  
Decal  
Abziehbilder  
Decalque



Barva  
Color  
Farben  
Poudre



Clear fix

Barvy GUNZE/ GUNZE Colour No.

A	Základová/Primer	H312/C312
B	Černá/Black	H12/C33
C	Rezavá/Rust	H33
D	Bílá sněhová/White Snow	H21/C69
E	Pneu. sedlá/Tyre Black	H77/C137
F	Tmavý kov/Dark Iron	MC214
G	Hliník/Aluminium	H8/C8
H	Kůže/Leather	H17/C29
I	Chromová/Chrome	I59
J	Ocel, šedá/Steel Grey	H75/C25
K	Žlutá/Yellow	H4/C4
L	Stříbrná/Silver	H8/C8
M	Plátno/Linen	H85/C45
N	Písková/Sand	H79/C39
O	Hnědá/Brown	H37/C43
P	Sv. modrá/Light blue	H323/C323

1

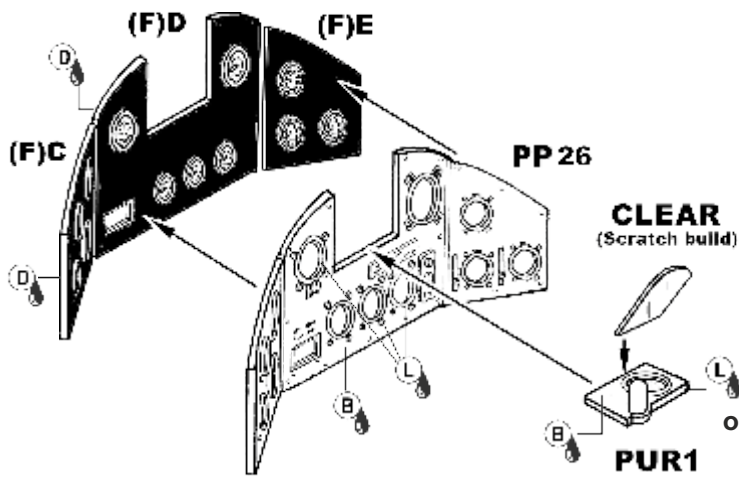

2

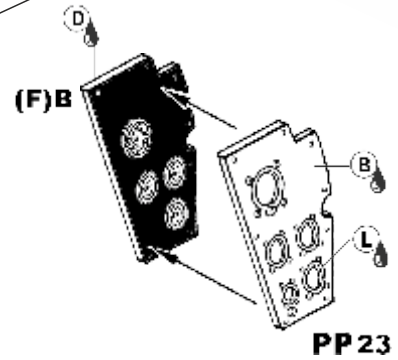

3

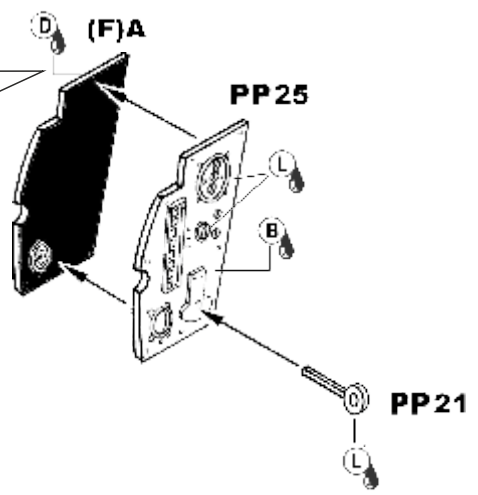

4

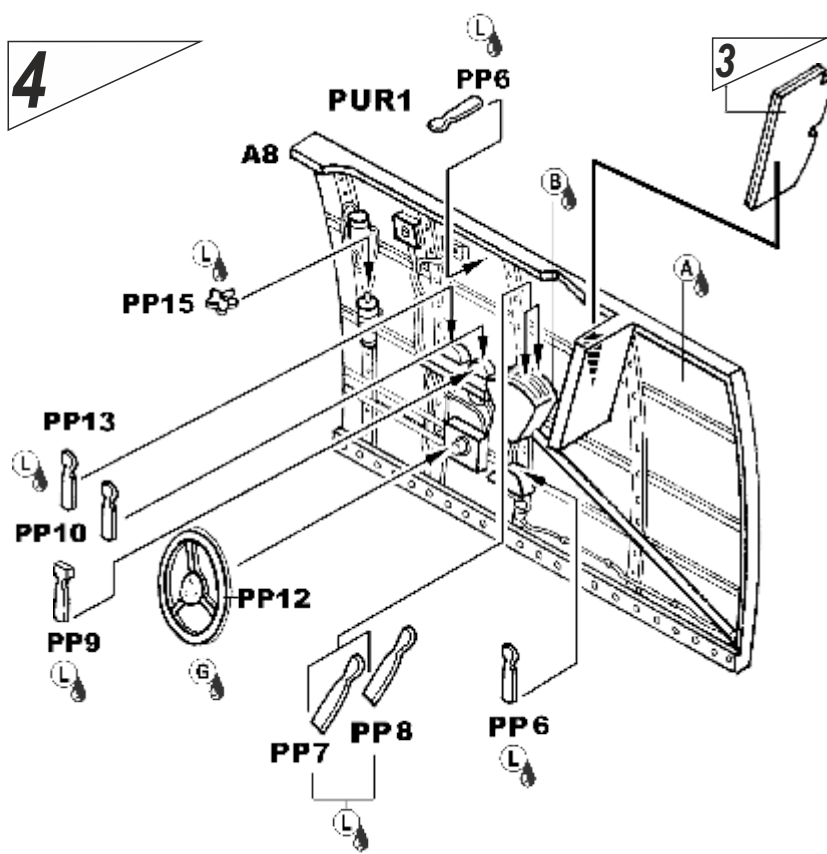

5

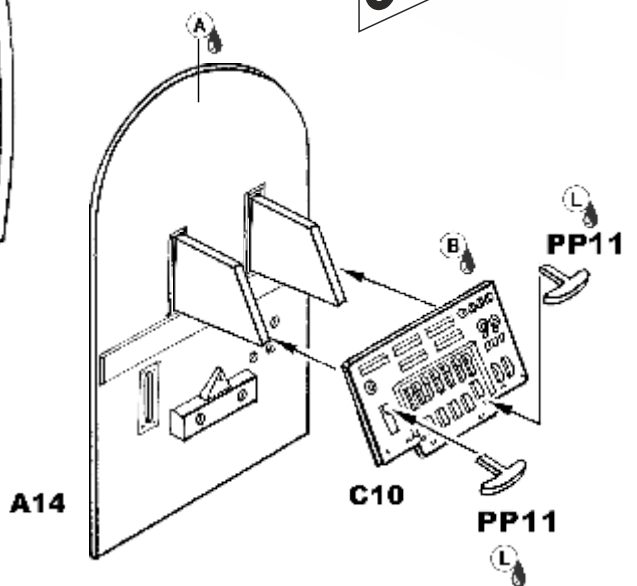

6

7

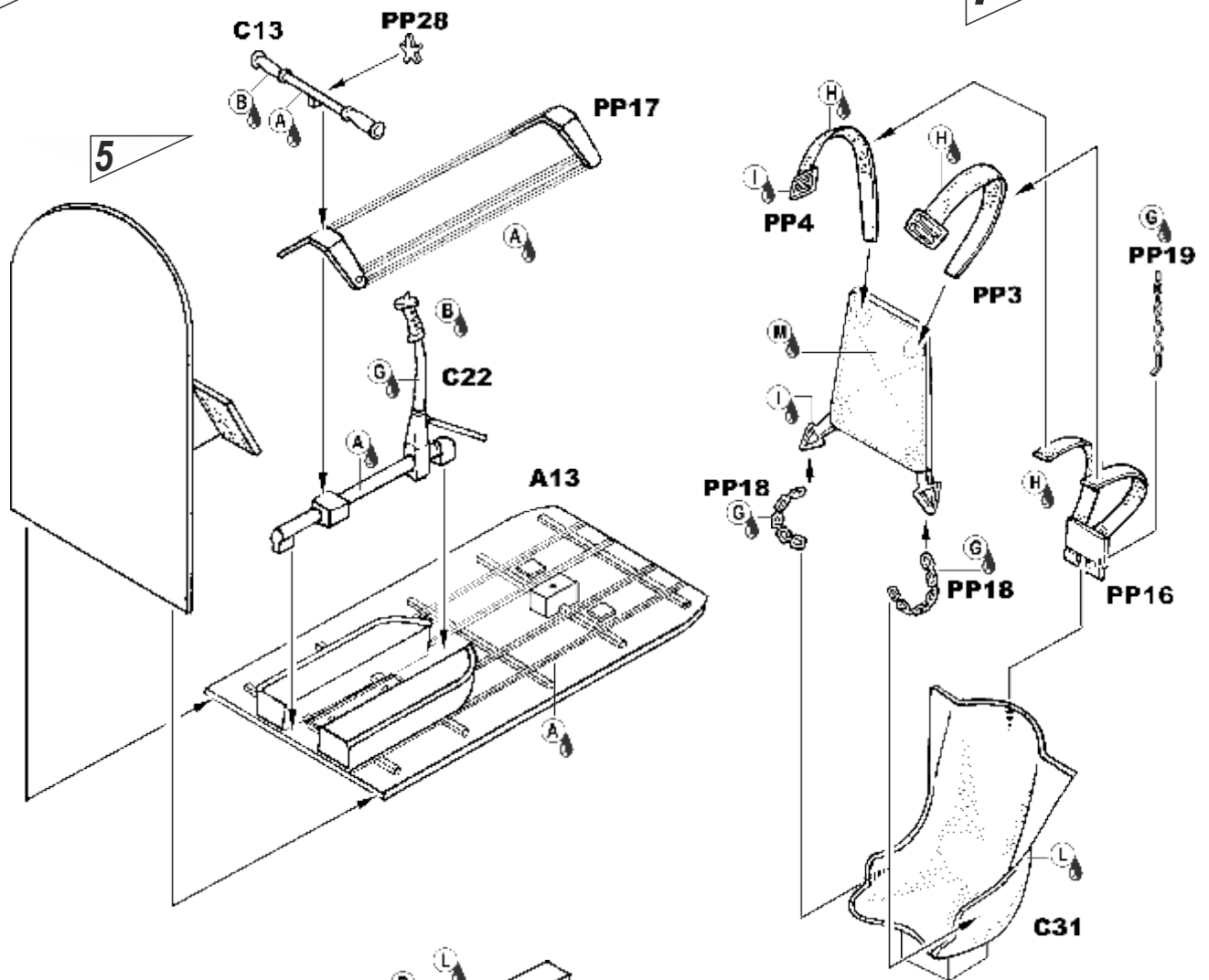

8

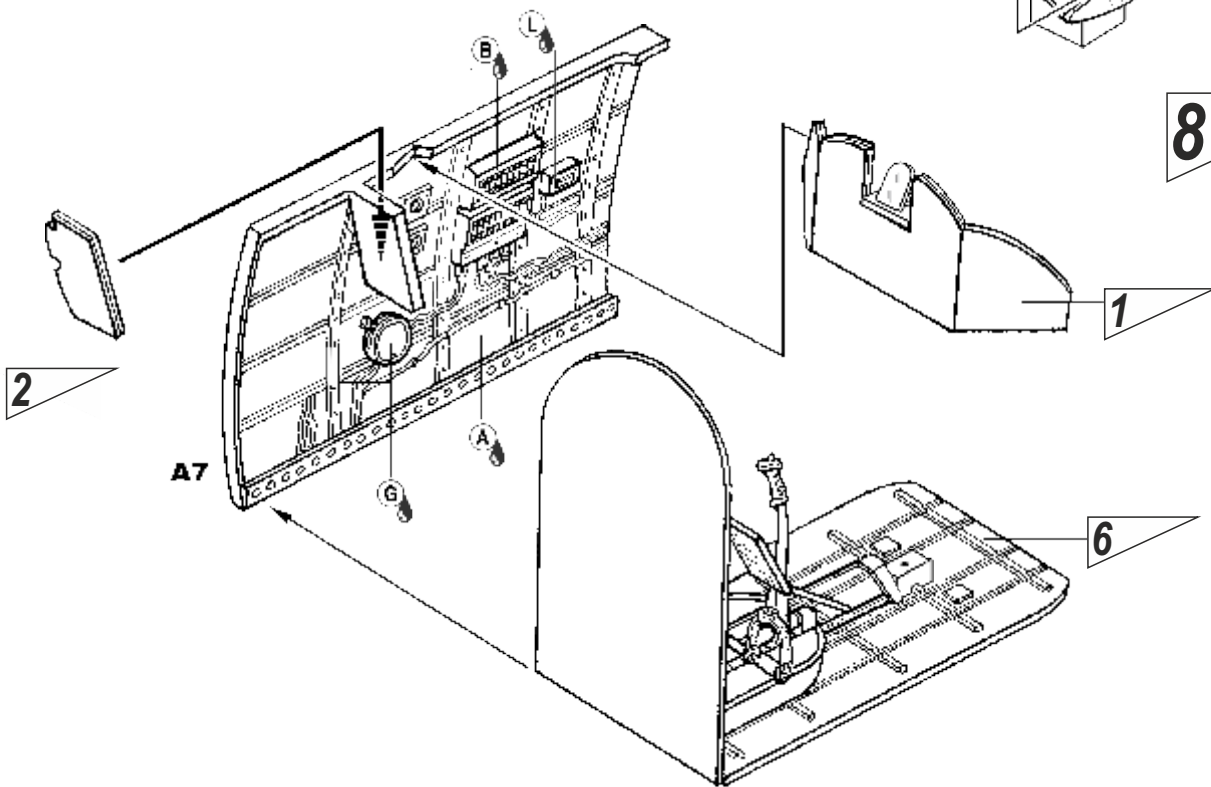

9

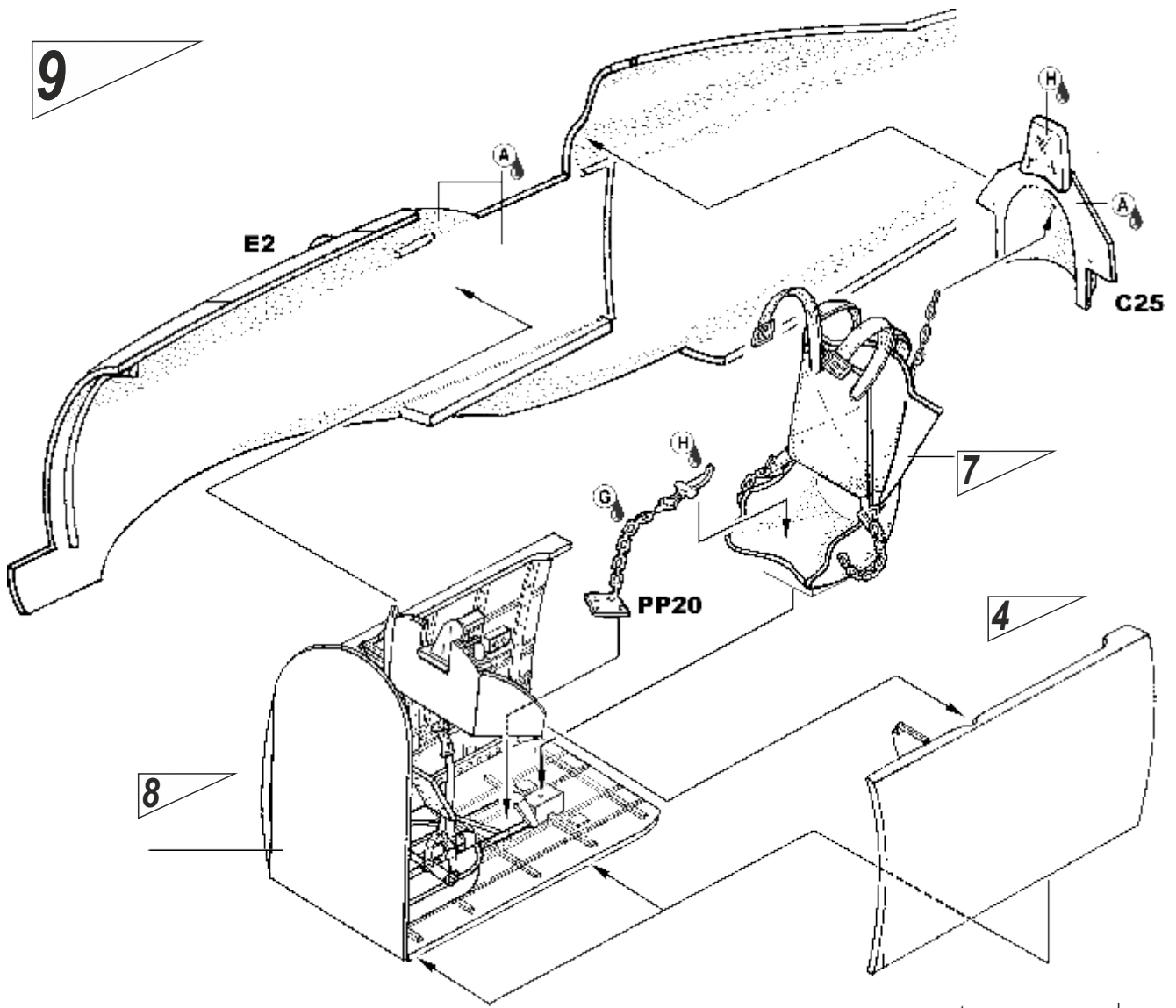

10

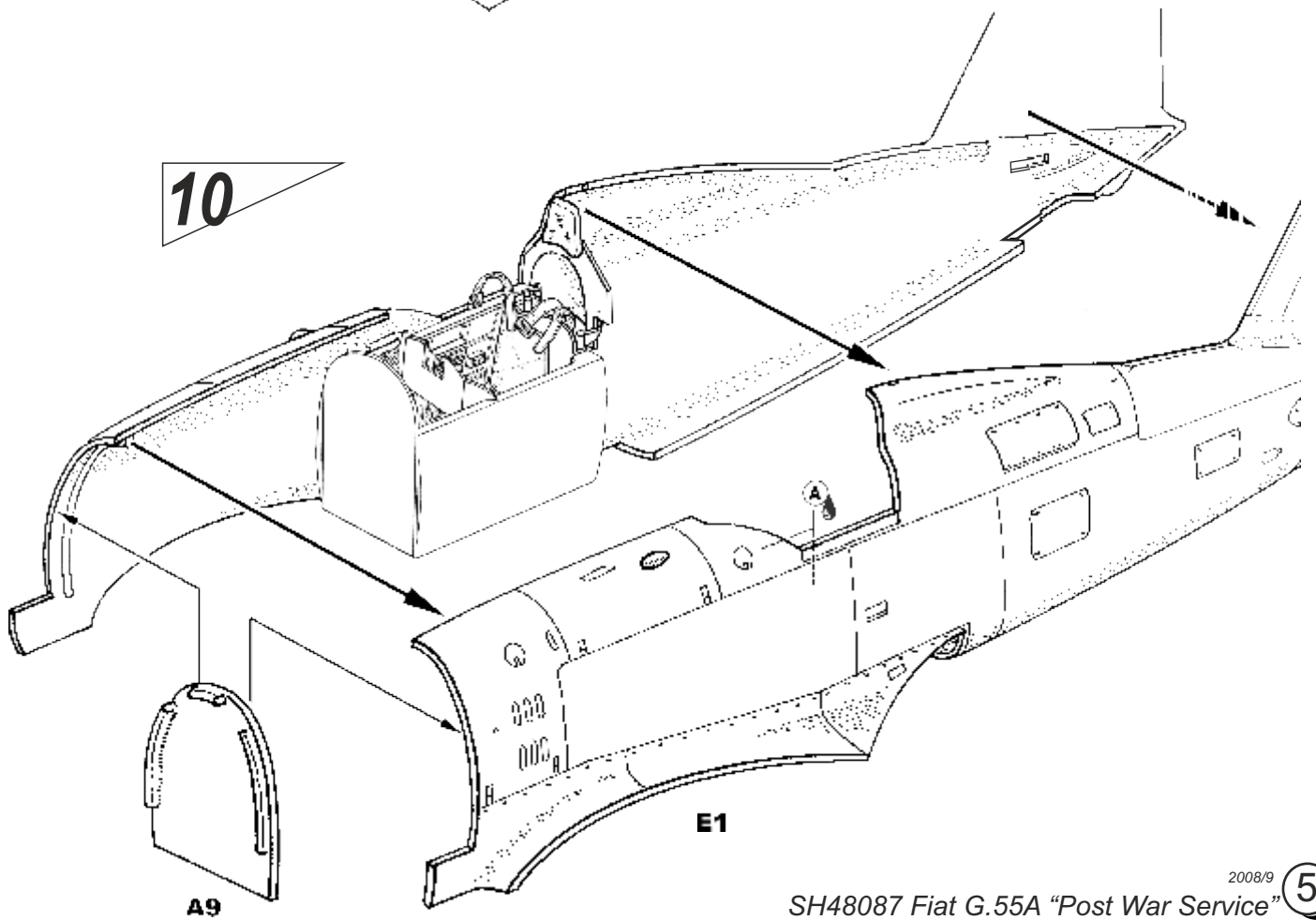

12

Glue together and drill a hole for tail wheel strut

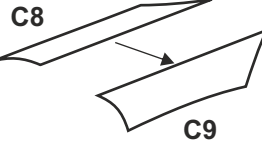
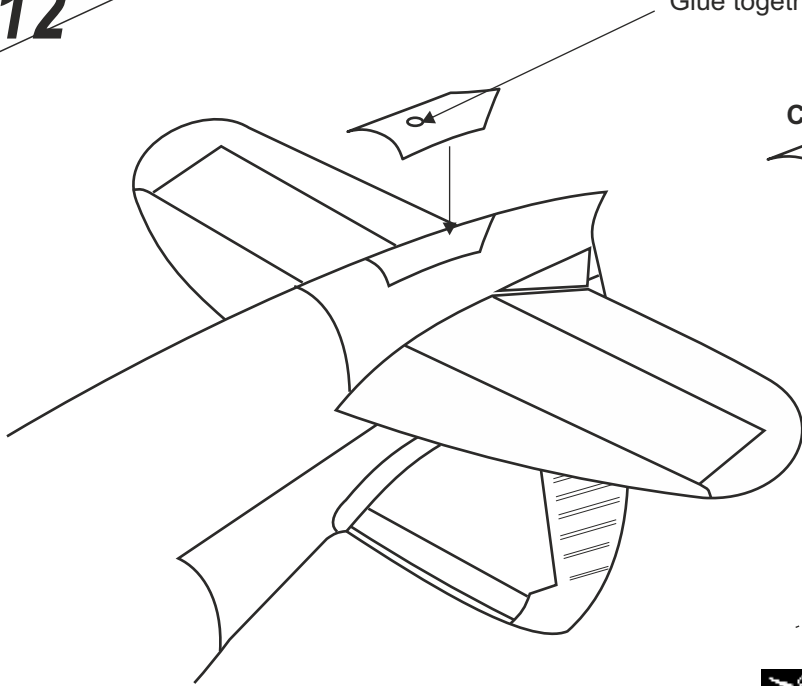

11

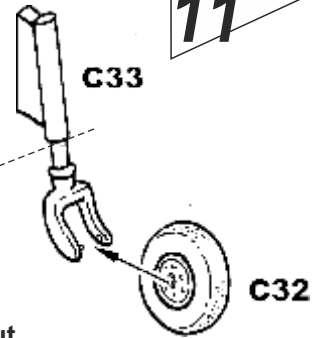

cut the tail wheel strut according to dimensions

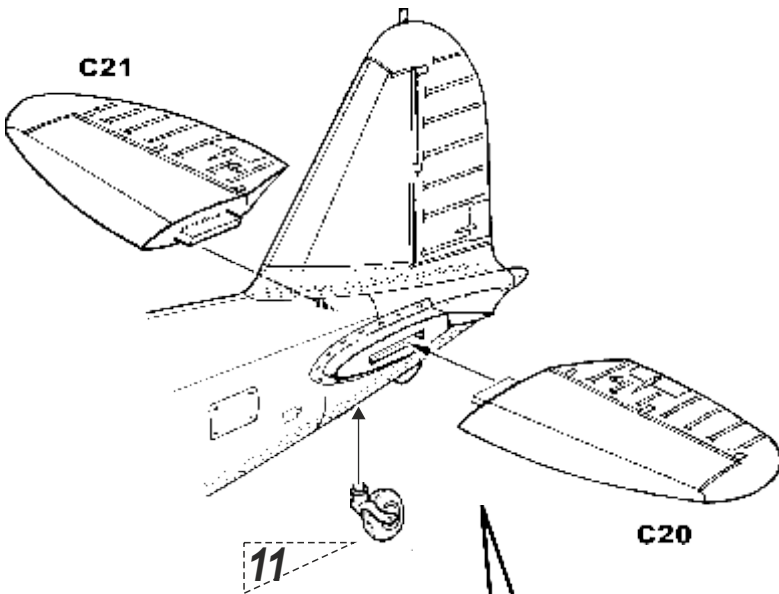

13

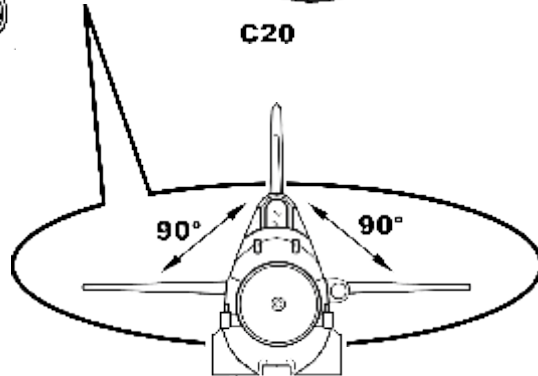

14

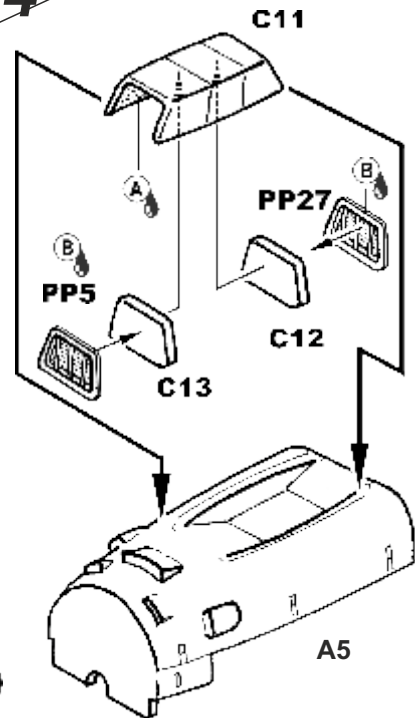

16

camo B,C  
PUR 2

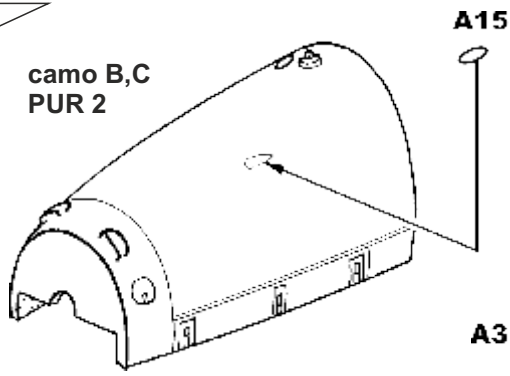

only camo A

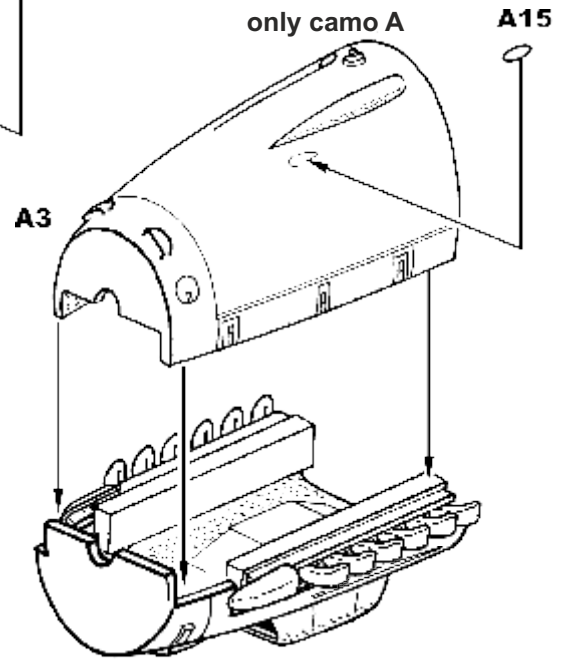

15

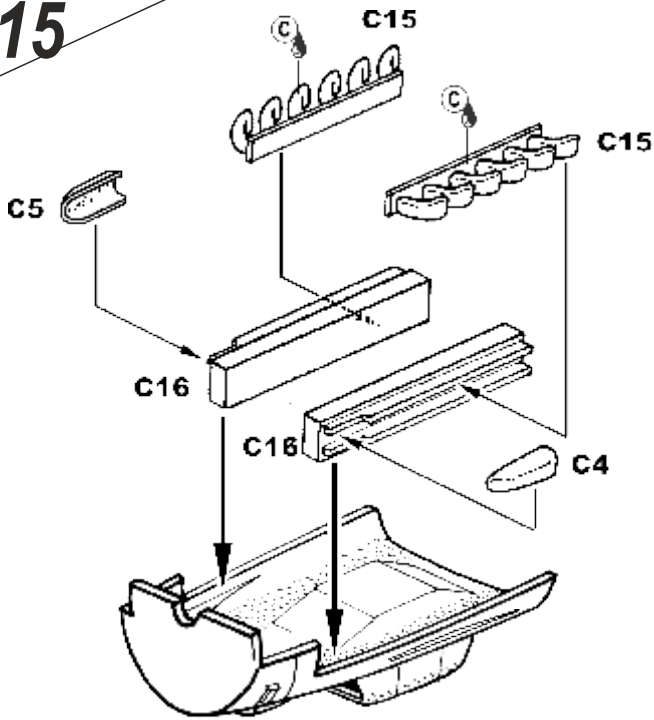

17

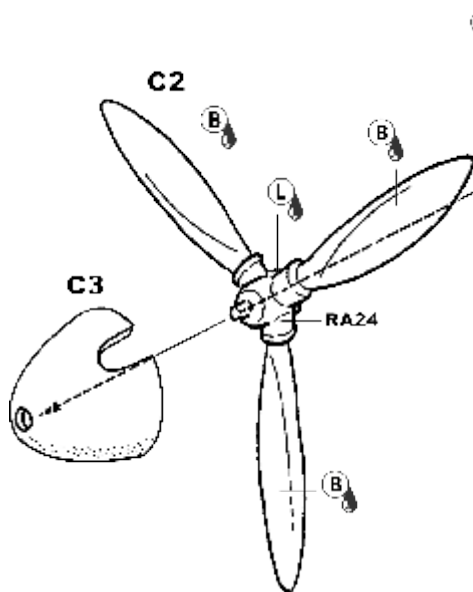
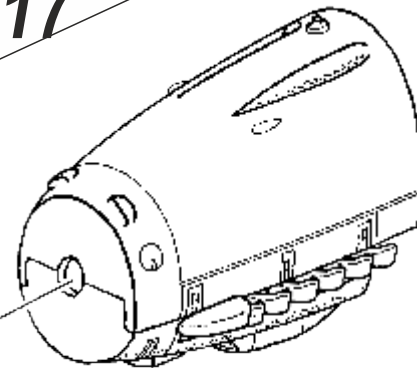

A15

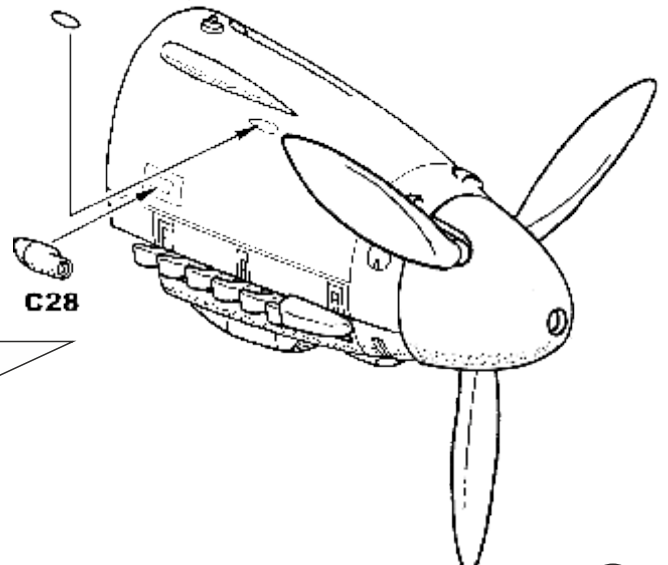

18

19

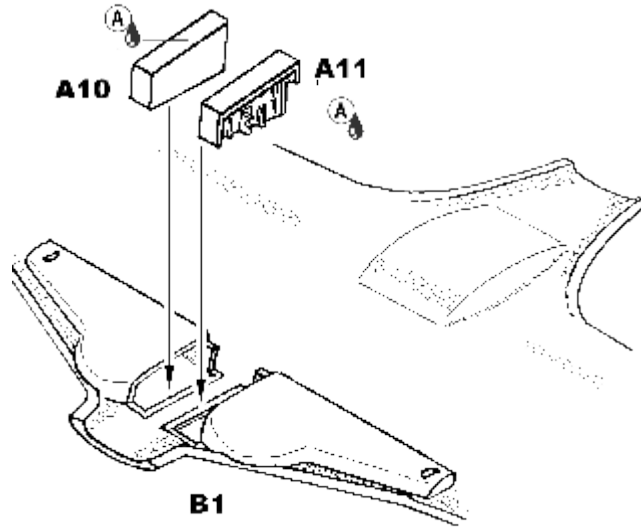

20

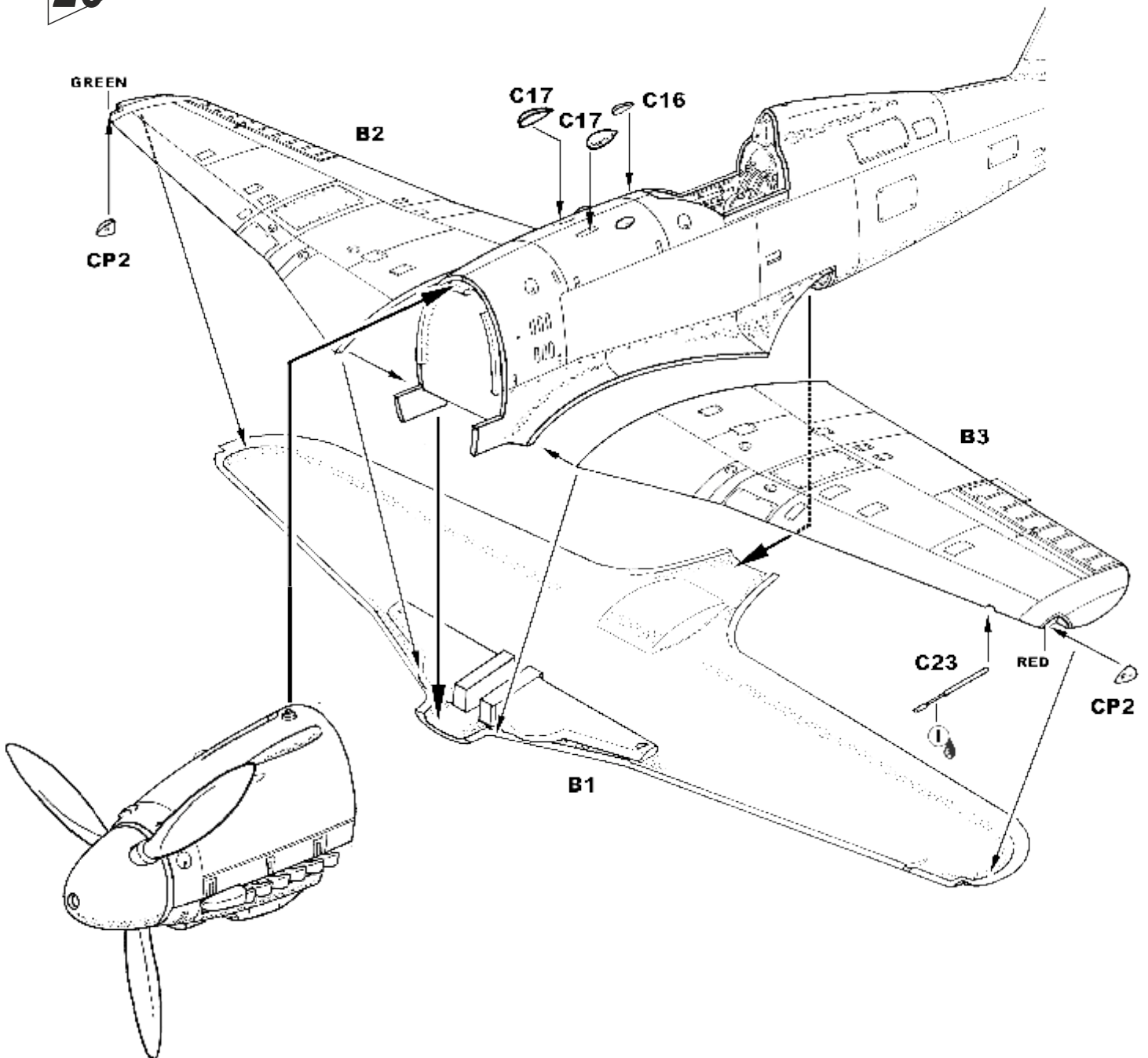



21

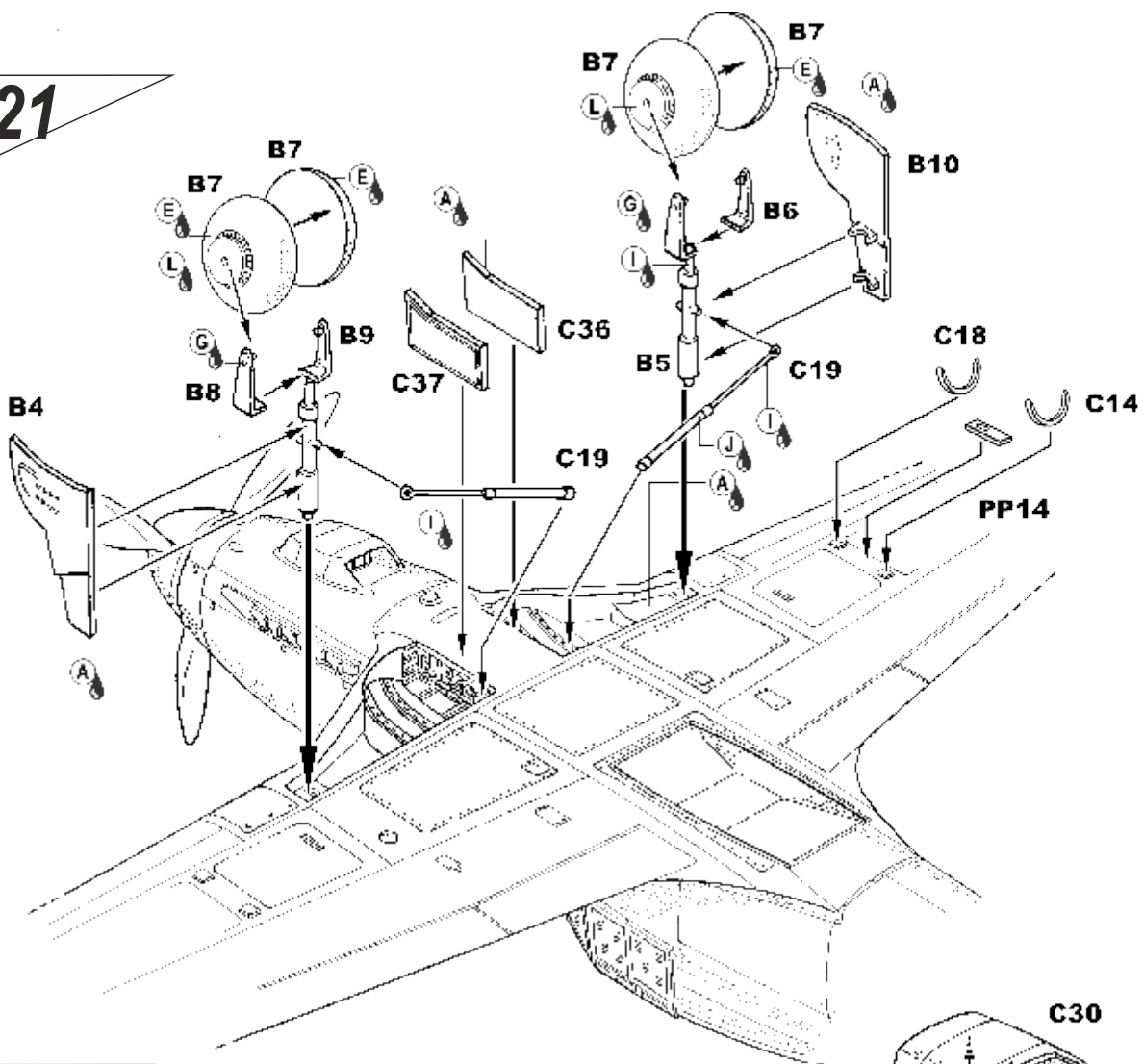

22

