

eduard

LIMITED



HRÁBĚ SU-25K

Instruction sheet

1/48

11176-NAV1



Carefully read instruction sheet before assembling. When you use glue or paint, do not use near open flame and use in well ventilated room. Keep out of reach of small children. Children must not be allowed to suck any part, or pull vinyl bag over the head.



Před započítím stavby si pečlivě prostudujte stavební návod. Při používání barev a lepidla pracujte v dobře větrané místnosti. Lepidla ani barvy nepoužívejte v blízkosti otevřeného ohně. Model není určen malým dětem, mohlo by dojít k požití drobných dílů.

INSTRUCTION SIGNS * INSTR. SYMBOLS * INSTRUKTION SINNBILDEN * SYMBOLES * 記号の説明



OPTIONAL
VOLBA



BEND
OHNOUT



SAND
BROUSIT



OPEN HOLE
VYVRTAT OTVOR



SYMETRICAL ASSEMBLY
SYMETRICKÁ MONTÁŽ



REMOVE
ODŘÍZNOUT



REVERSE SIDE
OTOČIT



APPLY EDUARD MASK
AND PAINT
POUŽÍT EDUARD MASK
NABARVIT

PLEASE CHECK THE LATEST VERSION OF THE INSTRUCTIONS ON www.eduard.com

PARTS



DÍLY



TEILE



PIÈCES



部品

PLASTIC PARTS

A>

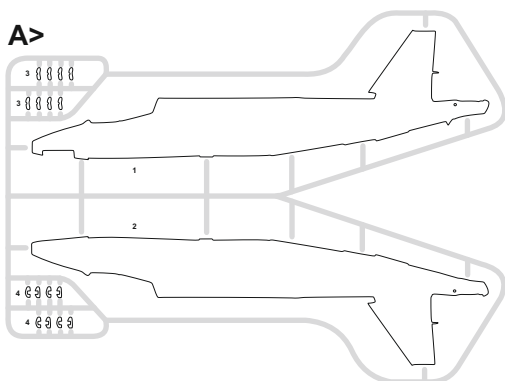

B>

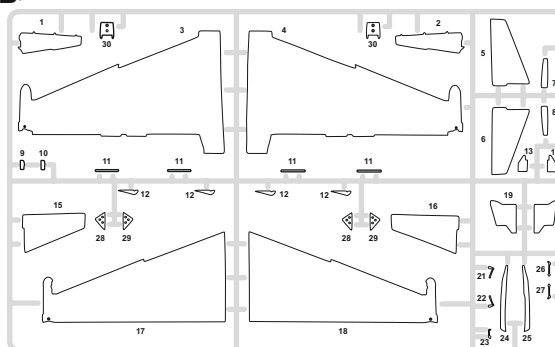

E> 2 pcs.

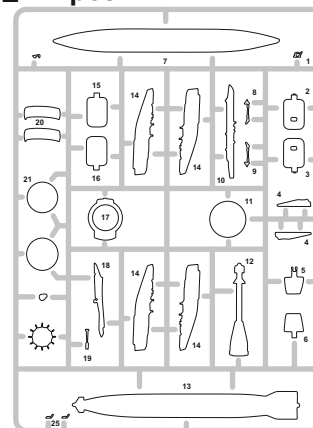

H> 4 pcs.

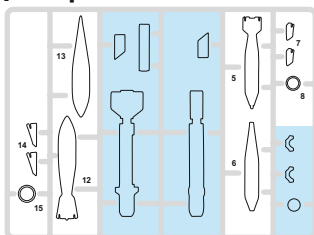

K> 4 pcs.

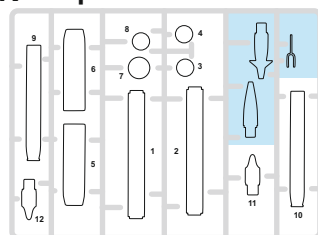

D>

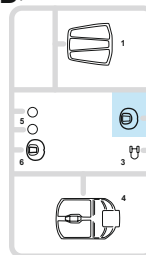

C>

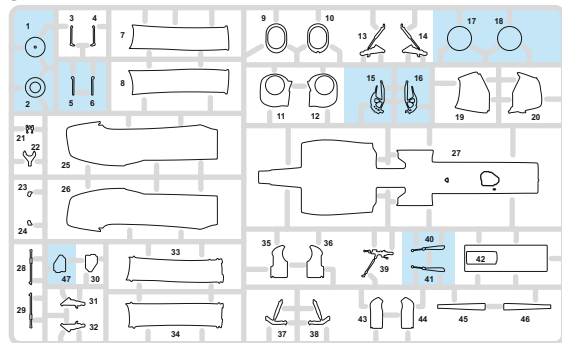

F>

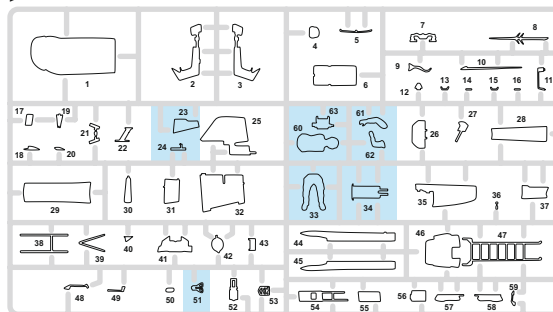

RP - RESIN PARTS



2 pcs.

2 pcs.



R13



R8



R6



R7



2 pcs.

R12



R4



R5



R11

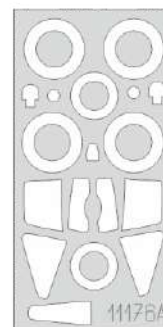
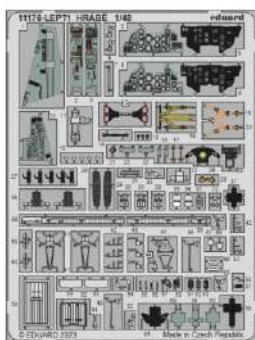

PE - PHOTO ETCHED DETAIL PARTS

eduard
MASK

-Parts not for use. -Teile werden nicht verwendet. -Pièces à ne pas utiliser. -Tyto díly nepoužívejte při stavbě. - 使用しない部品

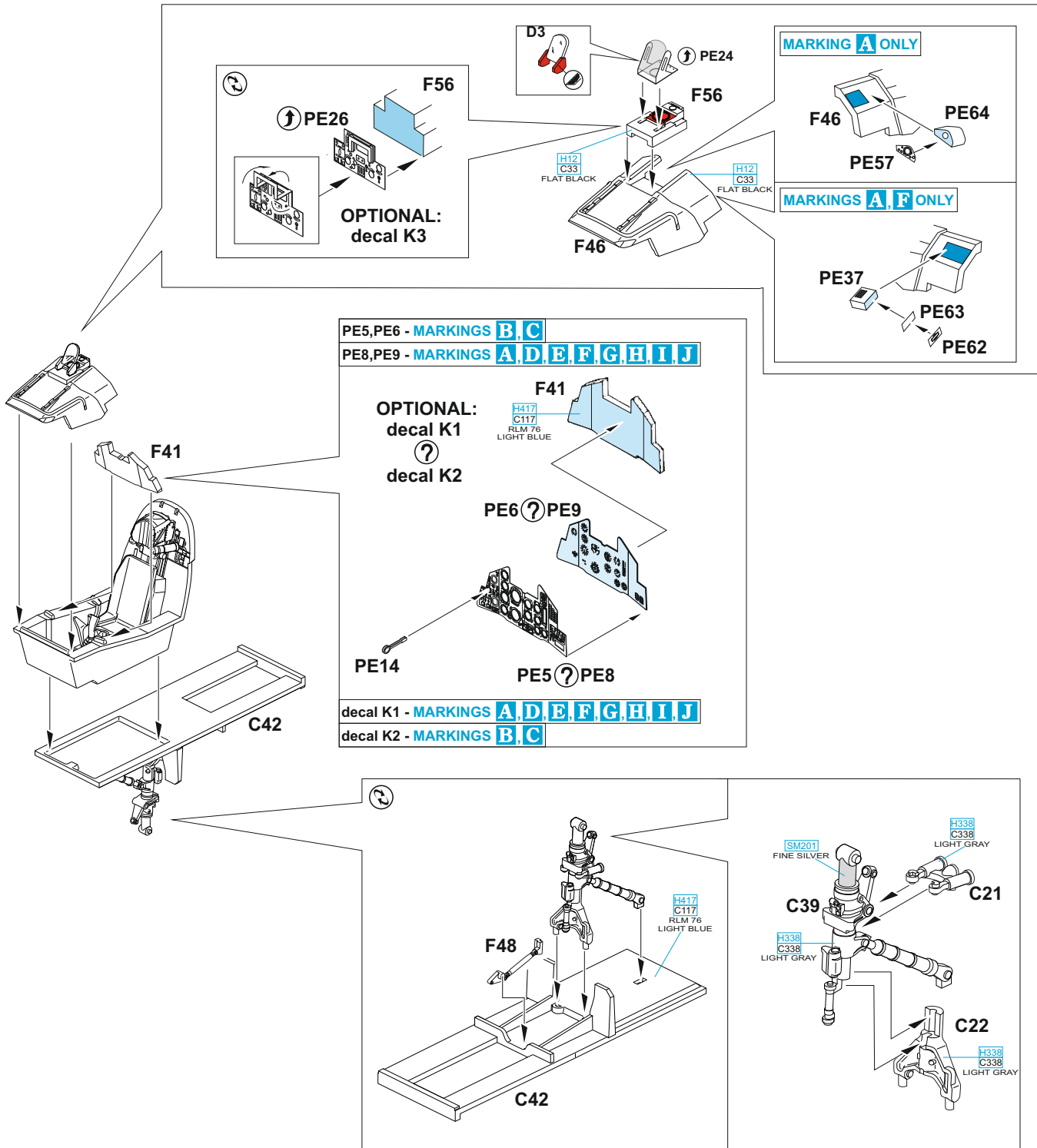
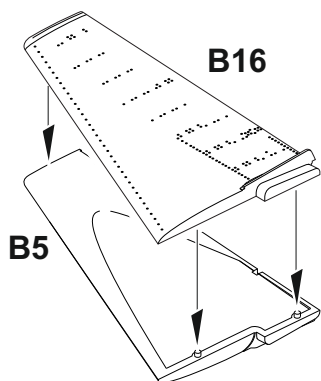
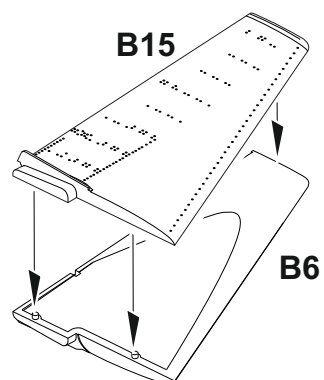
A**B****C**

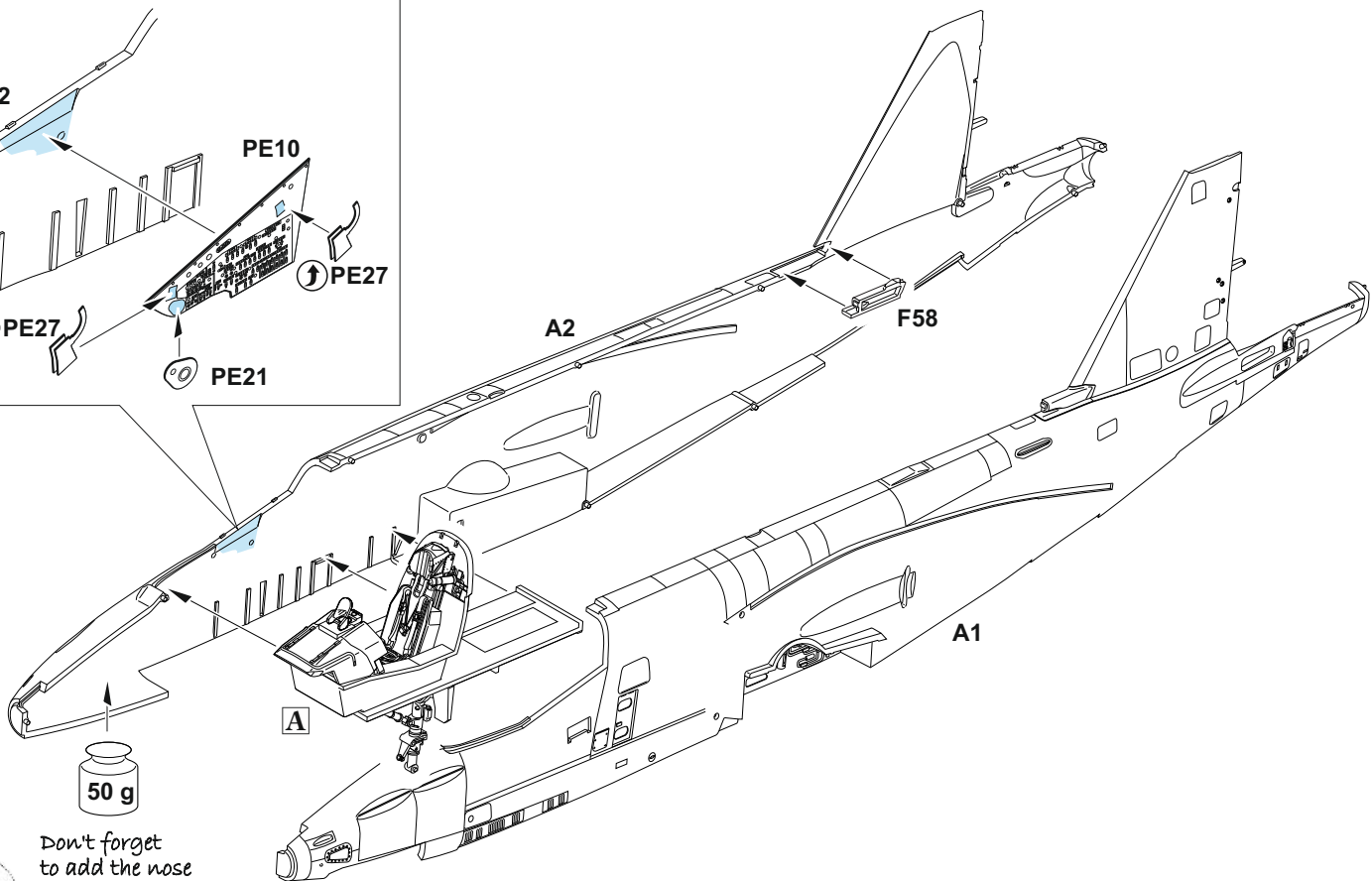
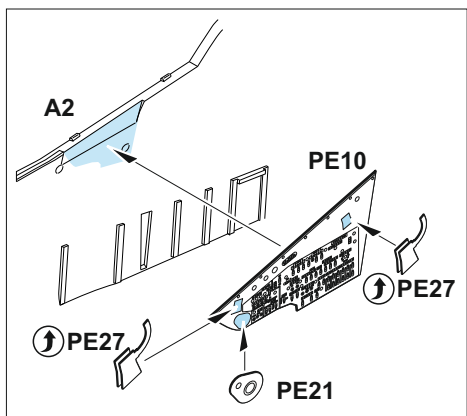
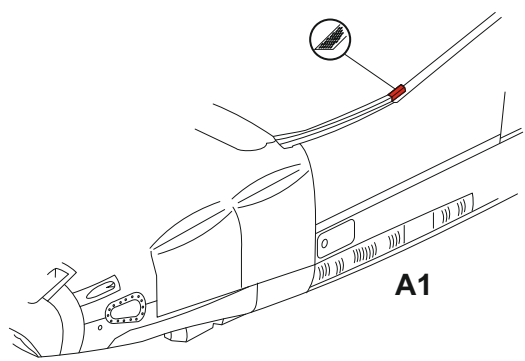
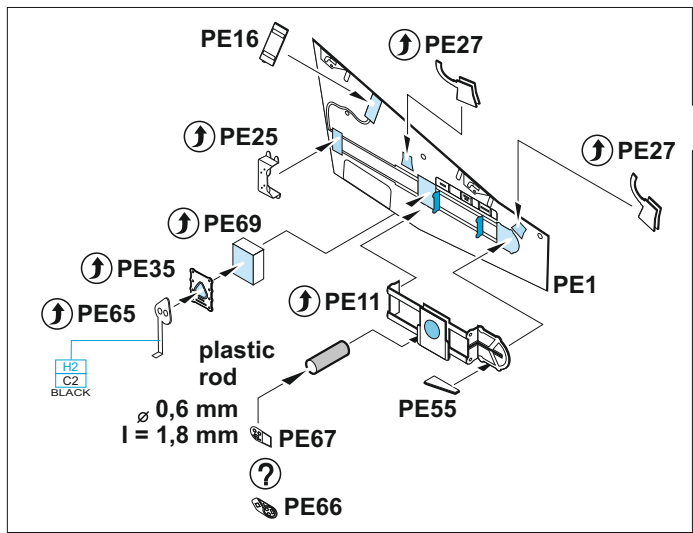
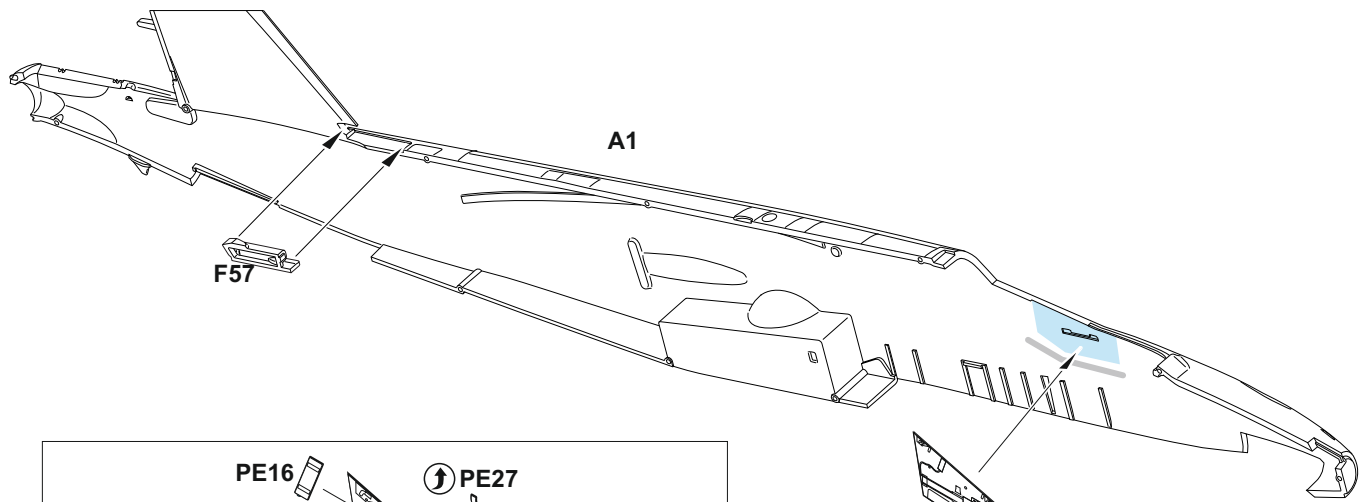

50 g
 Don't forget to add the nose weight balance!



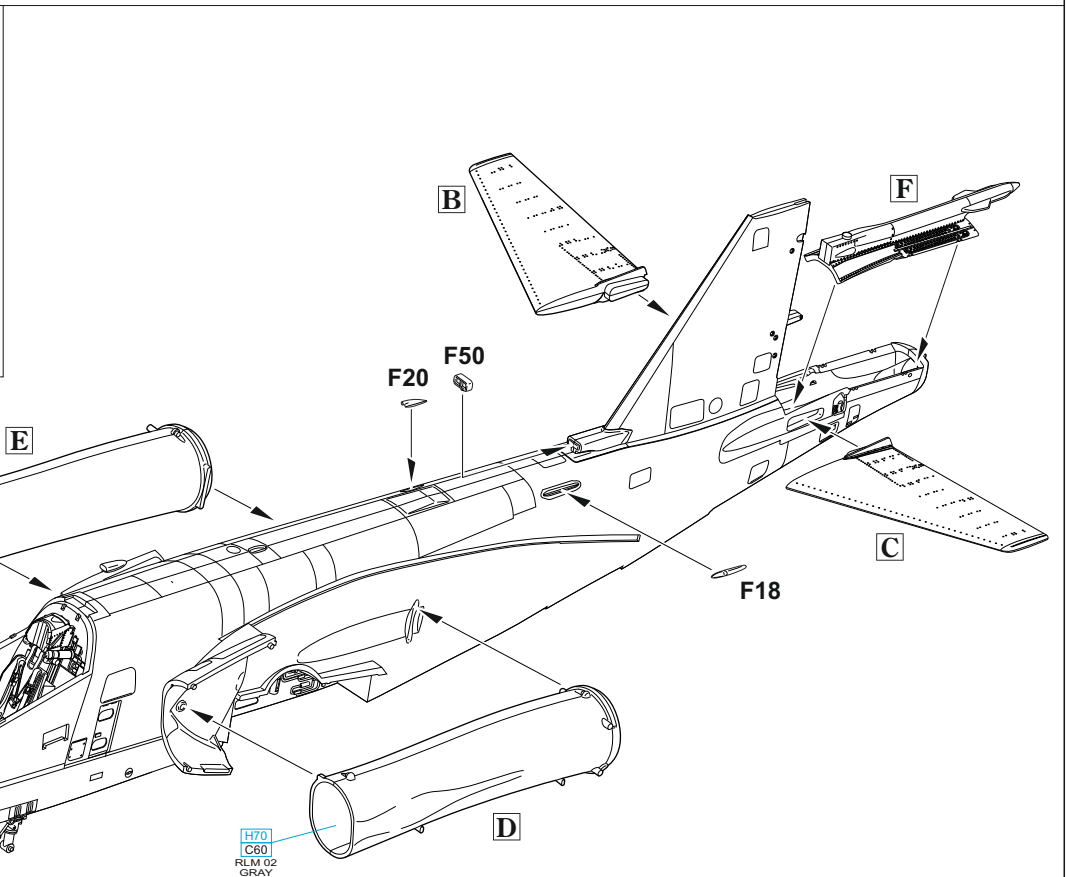
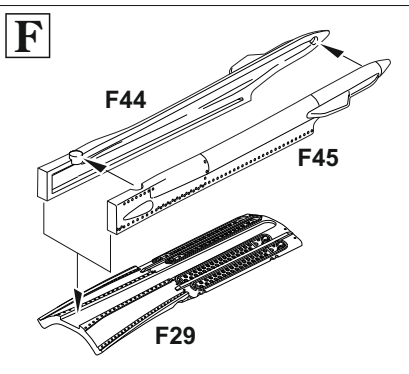
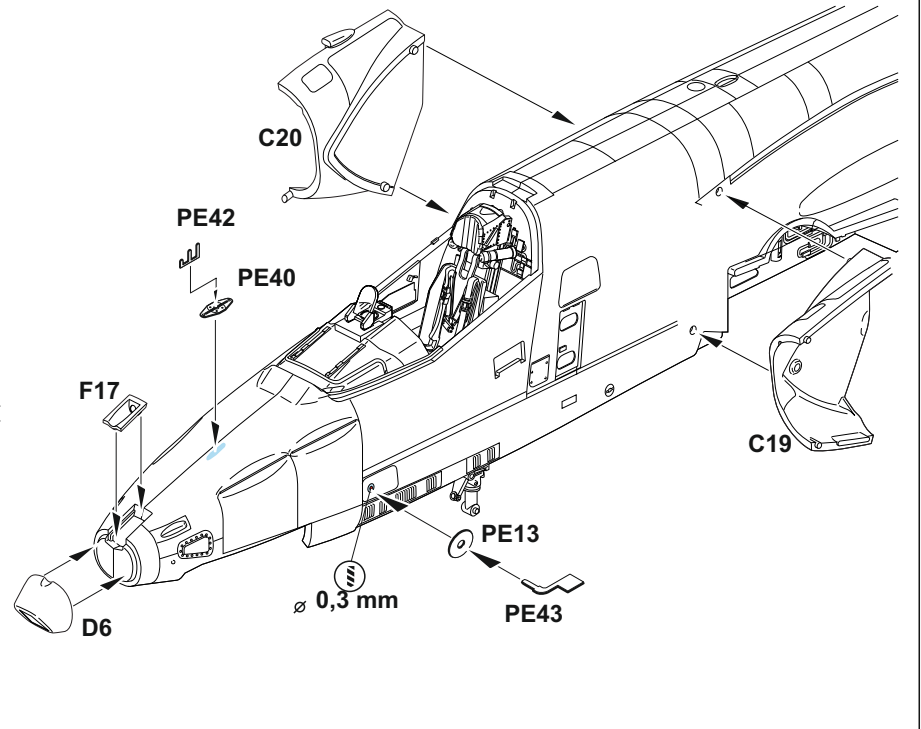
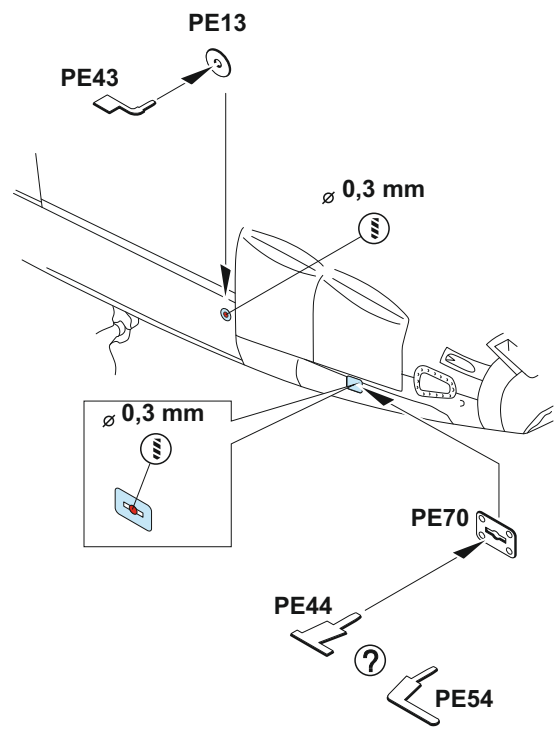
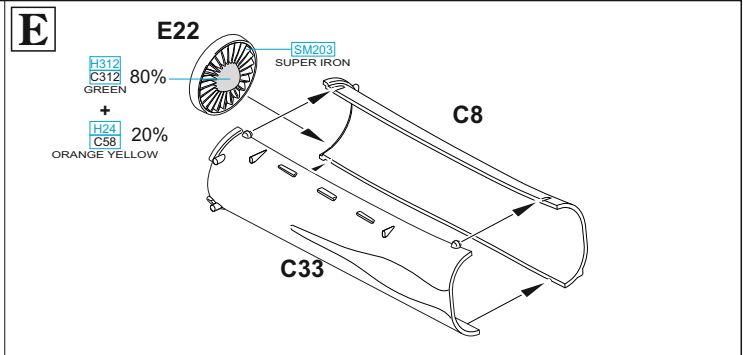
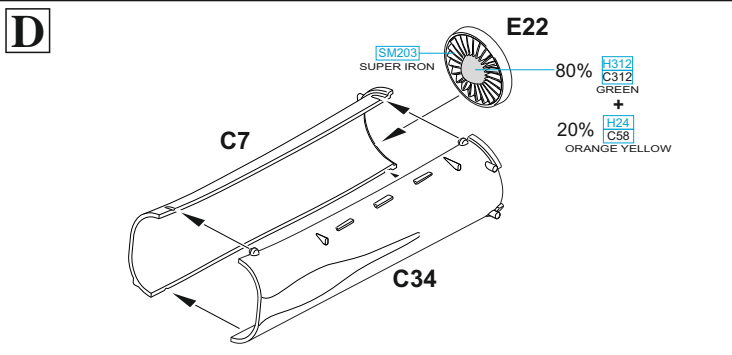

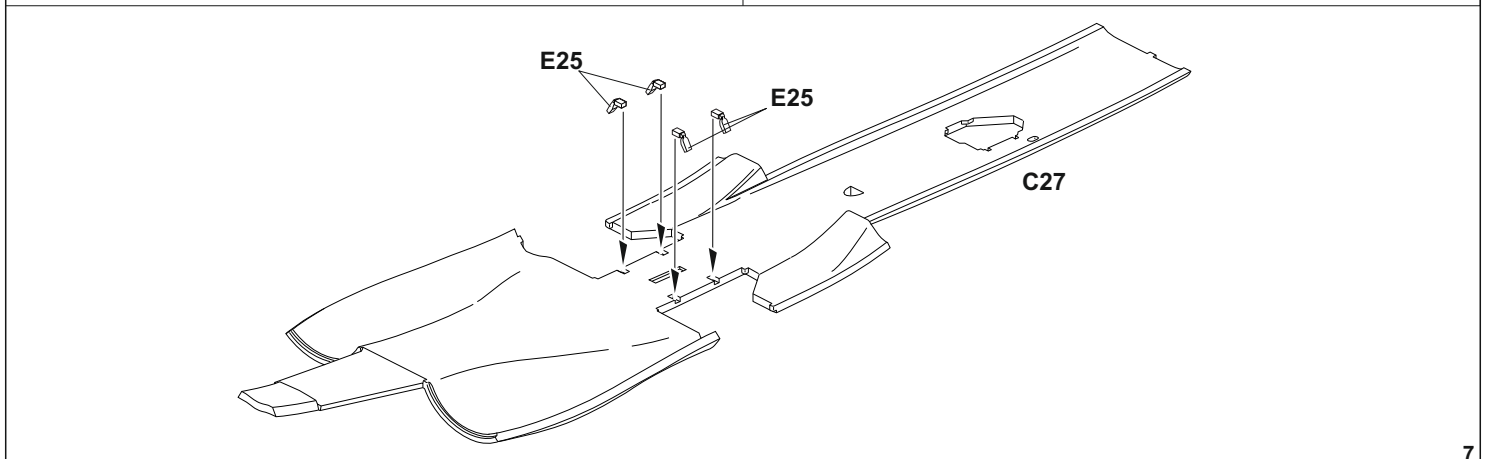
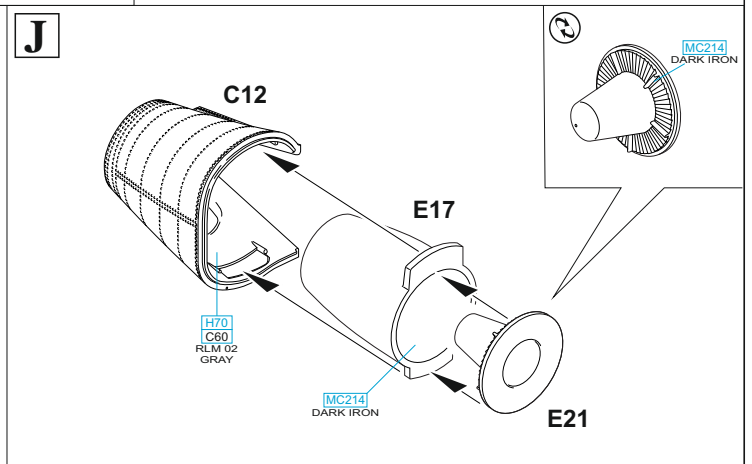
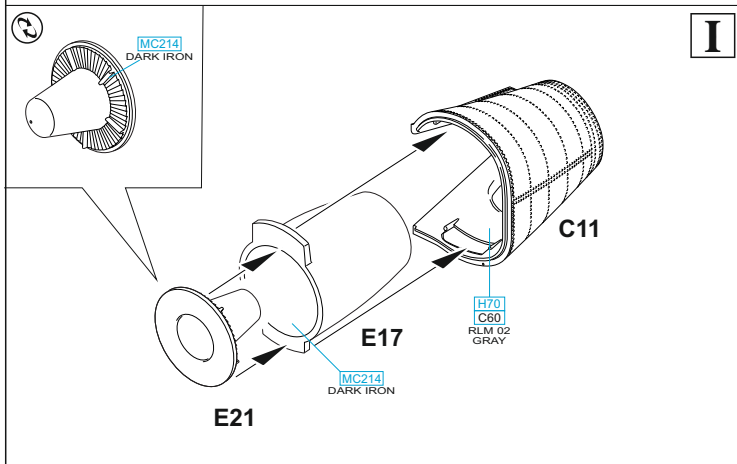
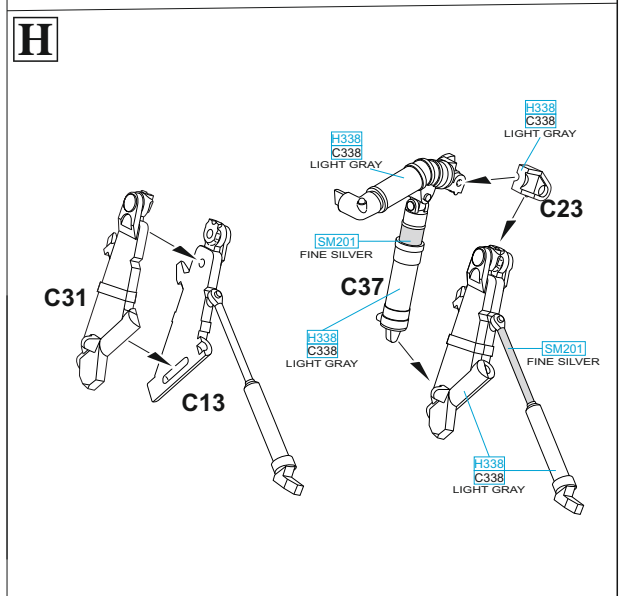
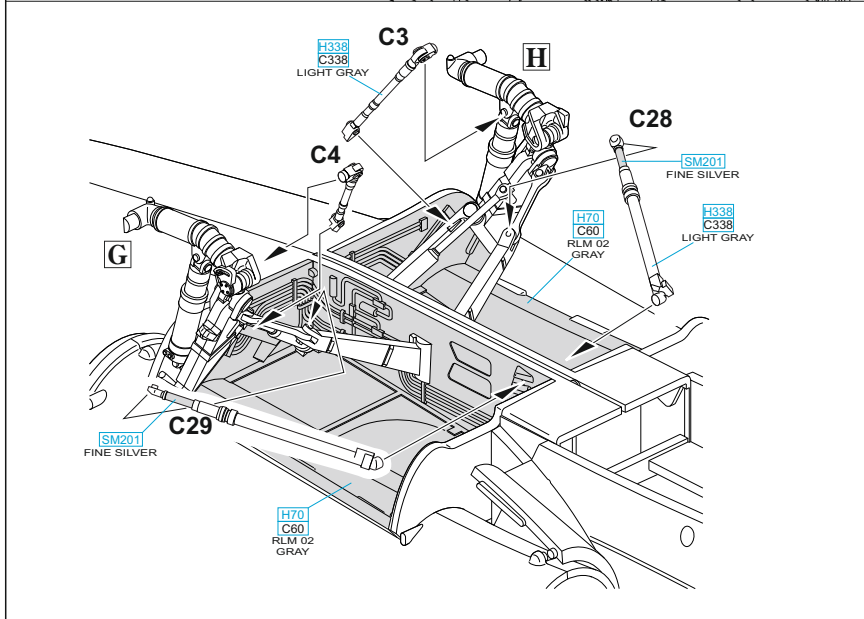
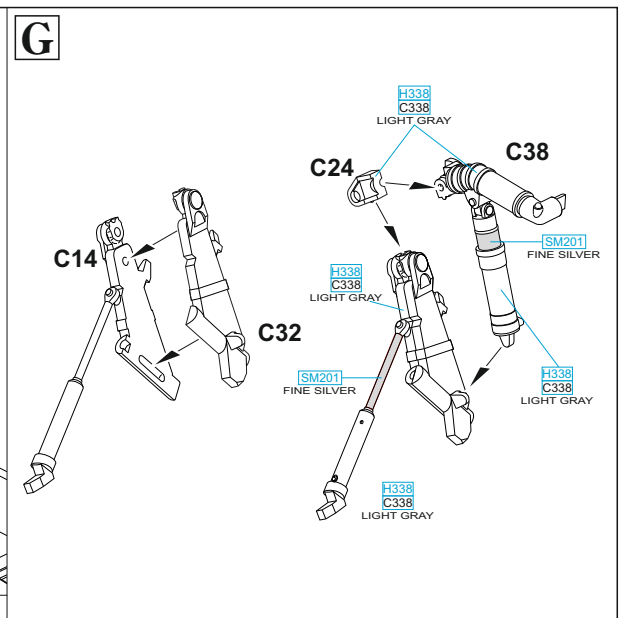
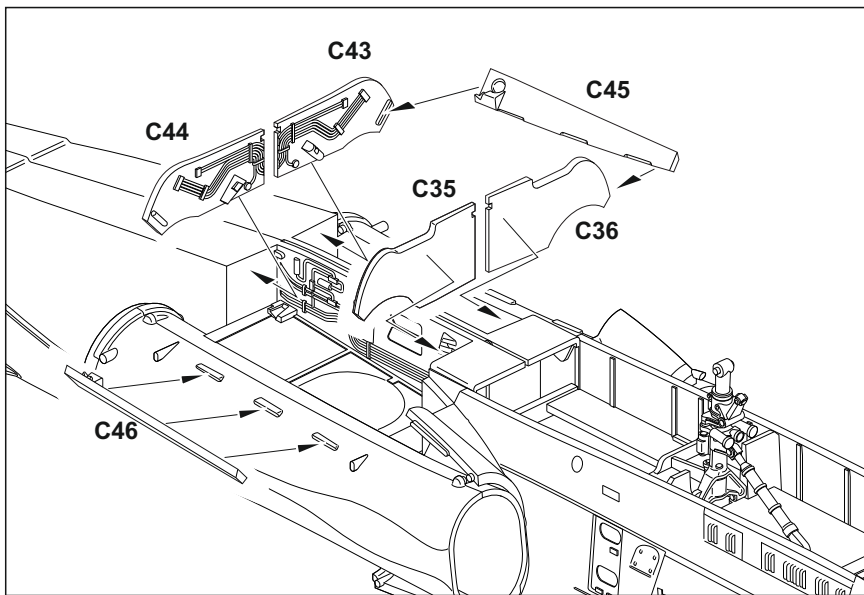

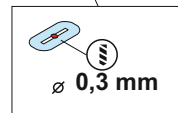
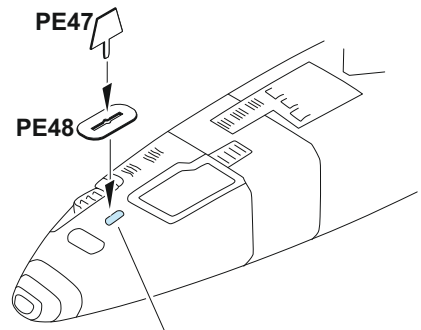
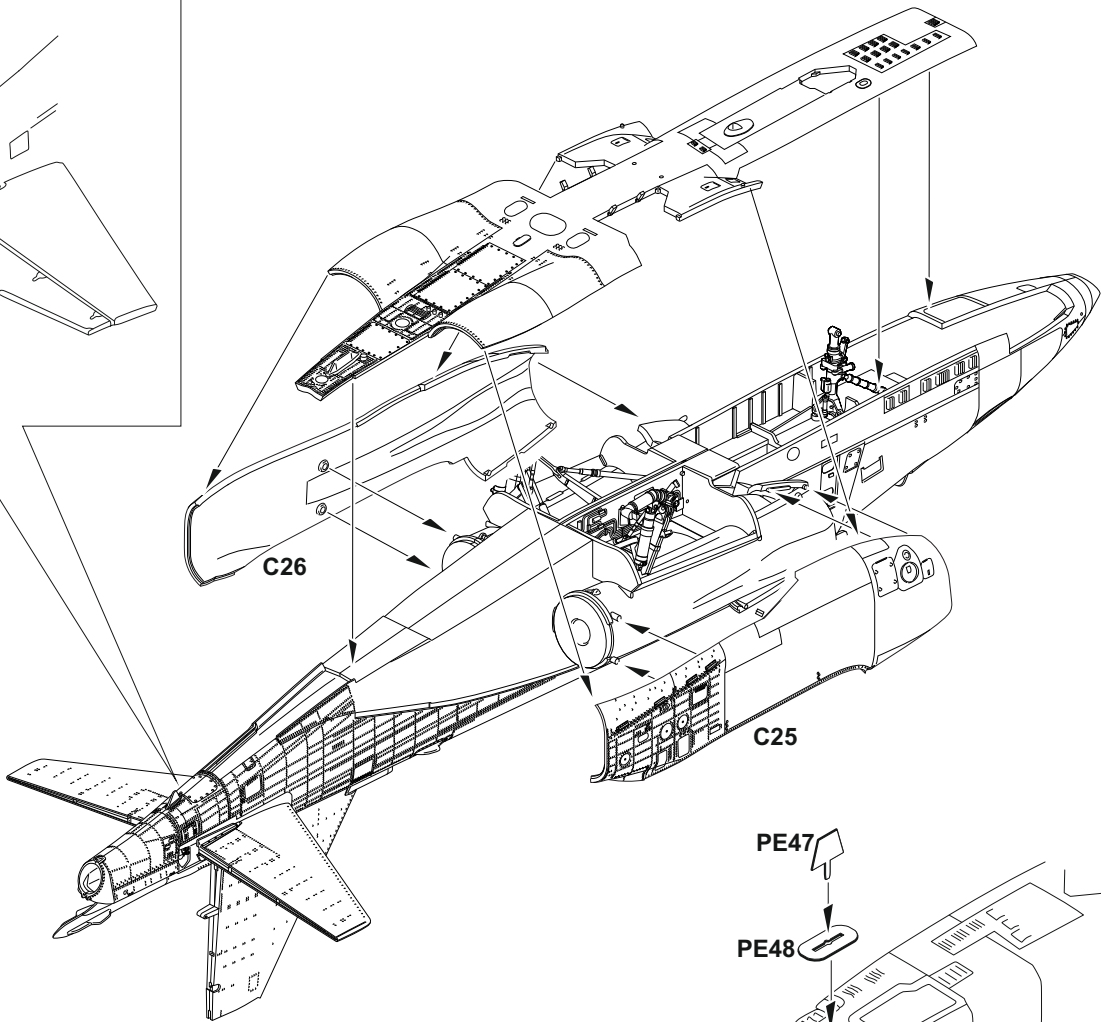
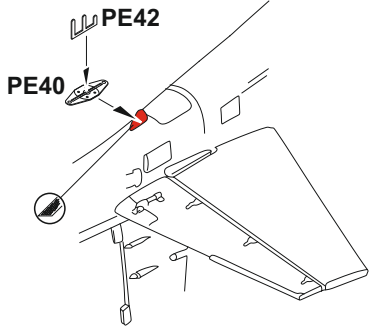

K

F52, F53 - MARKINGS **A, D, E, F, J**
R11 - MARKINGS **B, C, G, H, I**

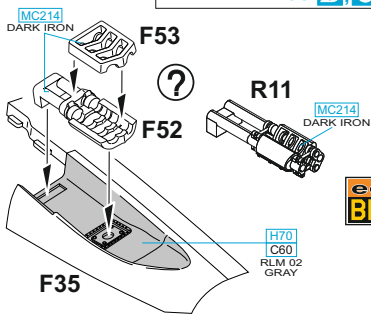

eduard
BRASSIN

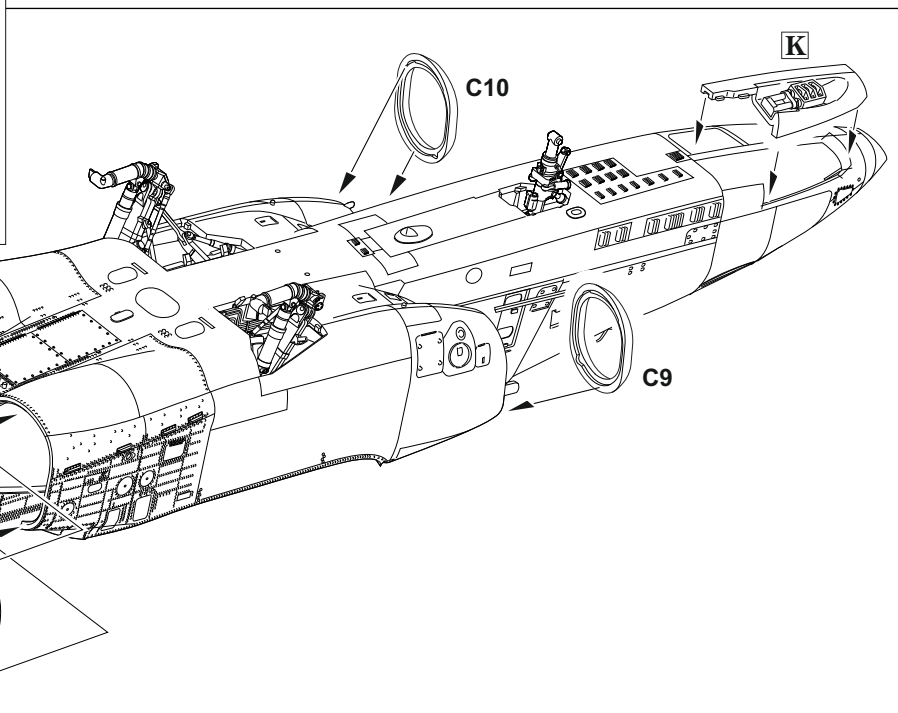

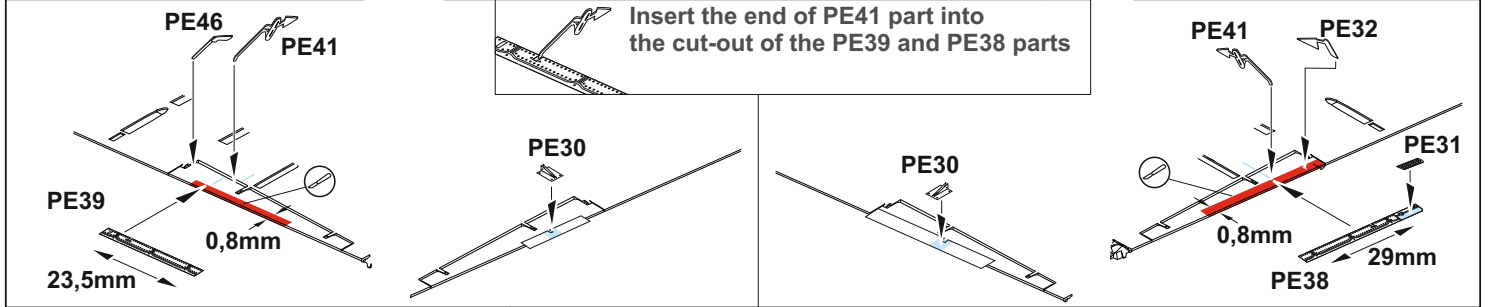
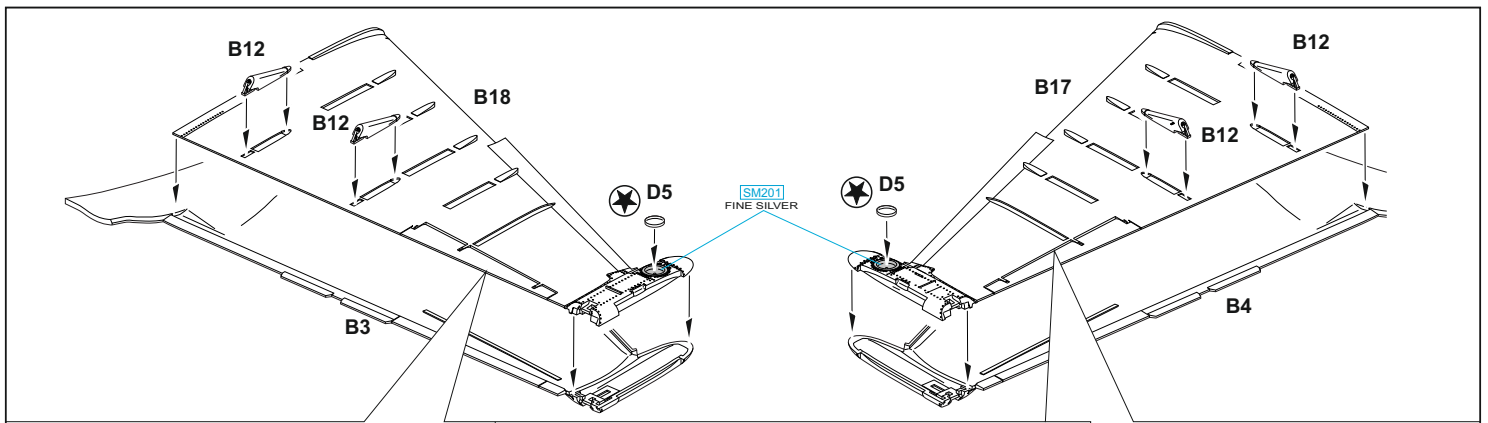

L MARKINGS **A, D, E, F, G, H, I, J** ONLY

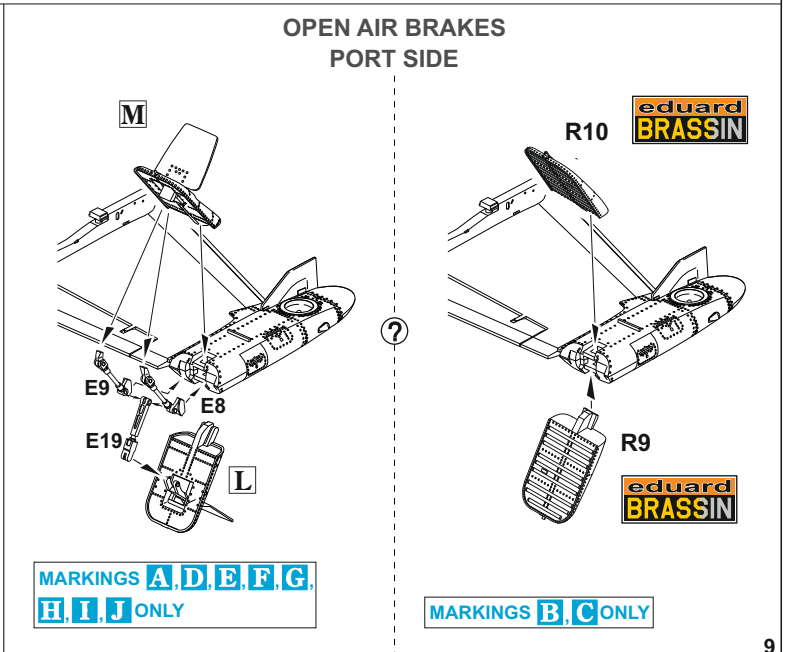
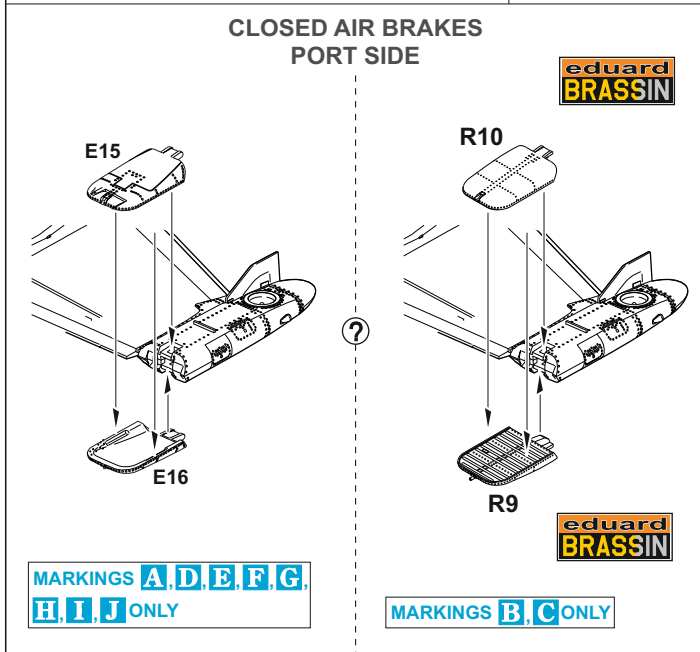
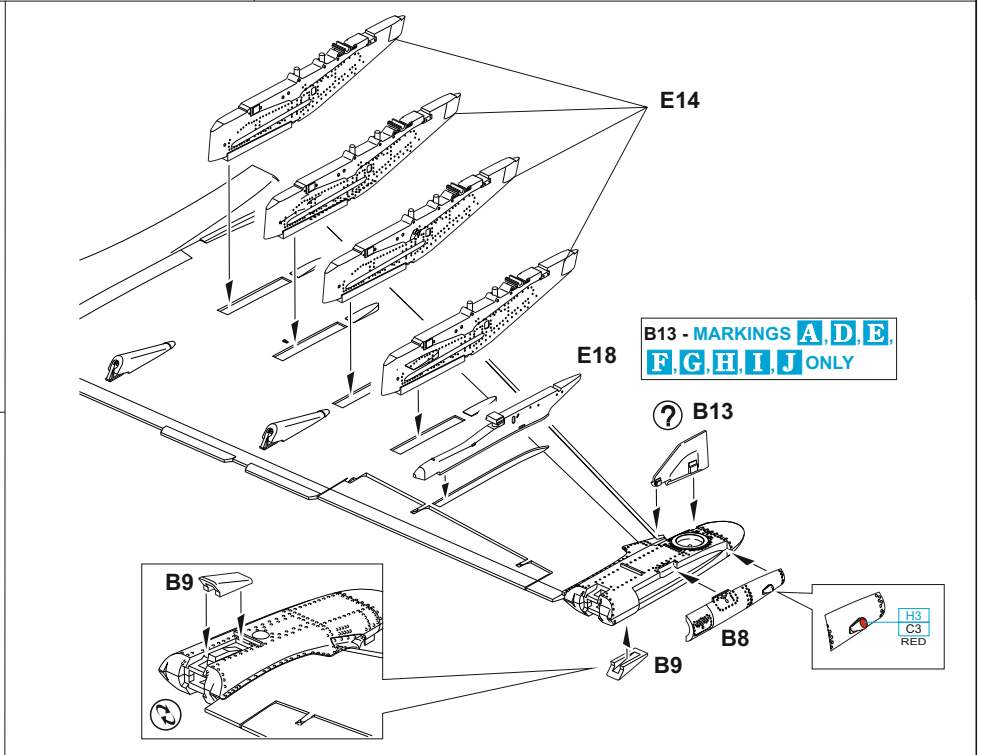
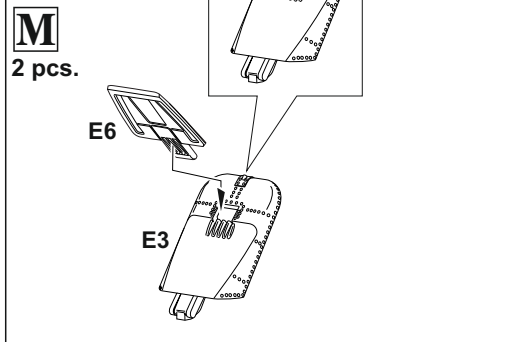
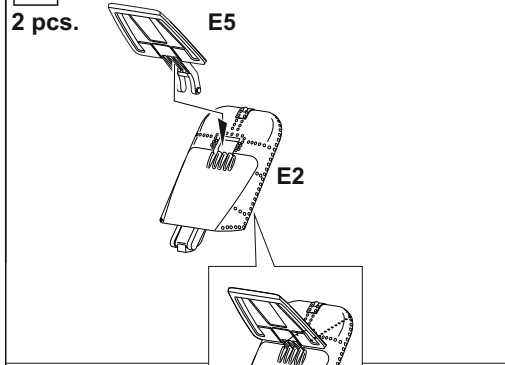

CLOSED AIR BRAKES
STARBOARD SIDE

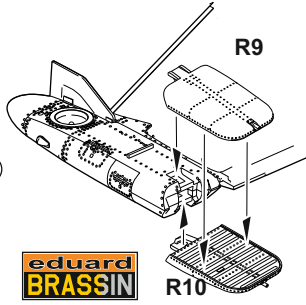
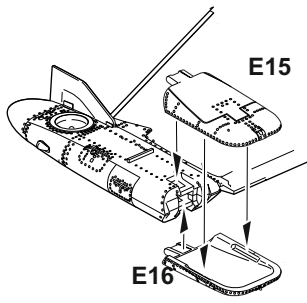

MARKINGS **A, D, E, F, G,**
H, I, J ONLY

MARKINGS **B, C** ONLY

OPEN AIR BRAKES
STARBOARD SIDE

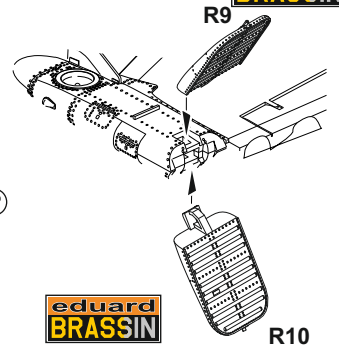
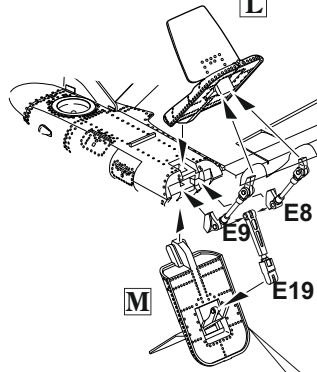

MARKINGS **A, D, E, F, G,**
H, I, J ONLY

MARKINGS **B, C** ONLY

B14 - MARKINGS **A, D, E,**
F, G, H, I, J ONLY

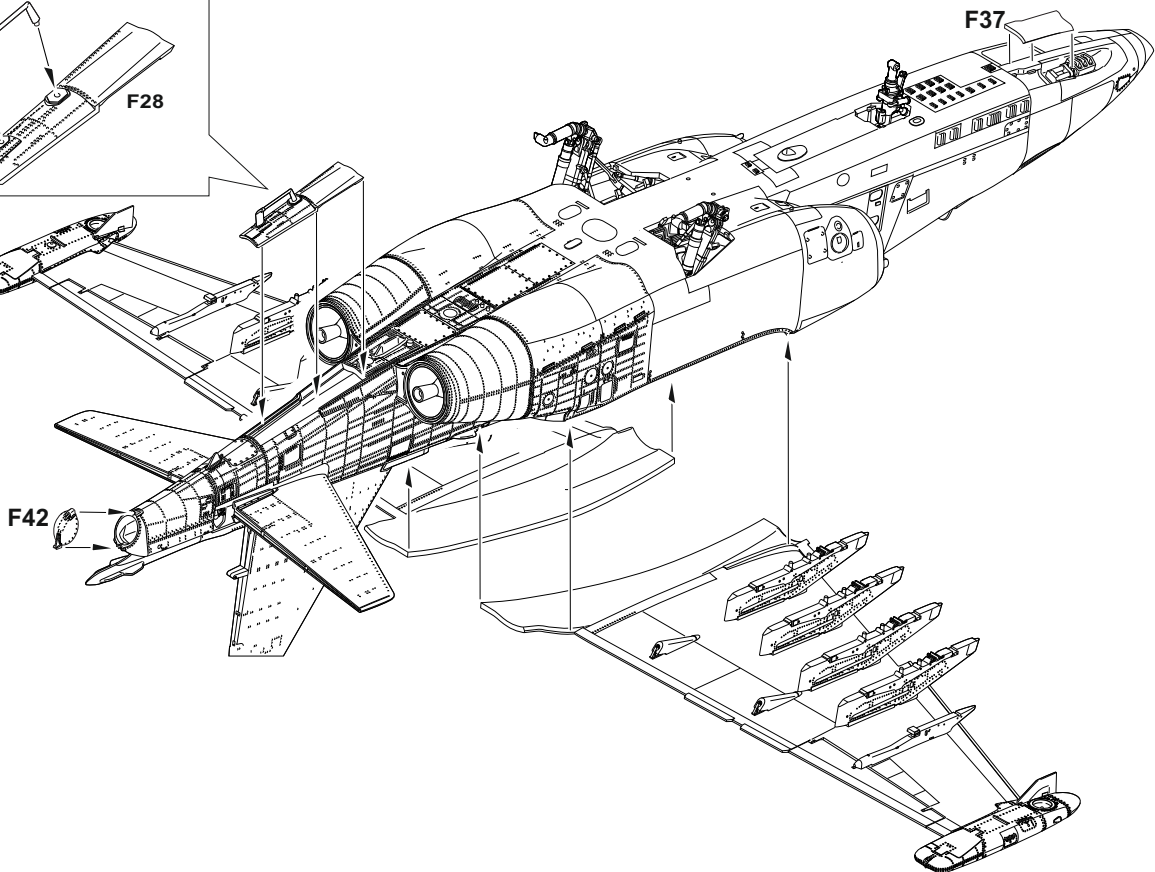
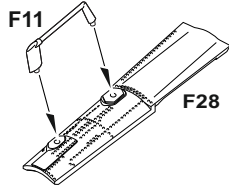
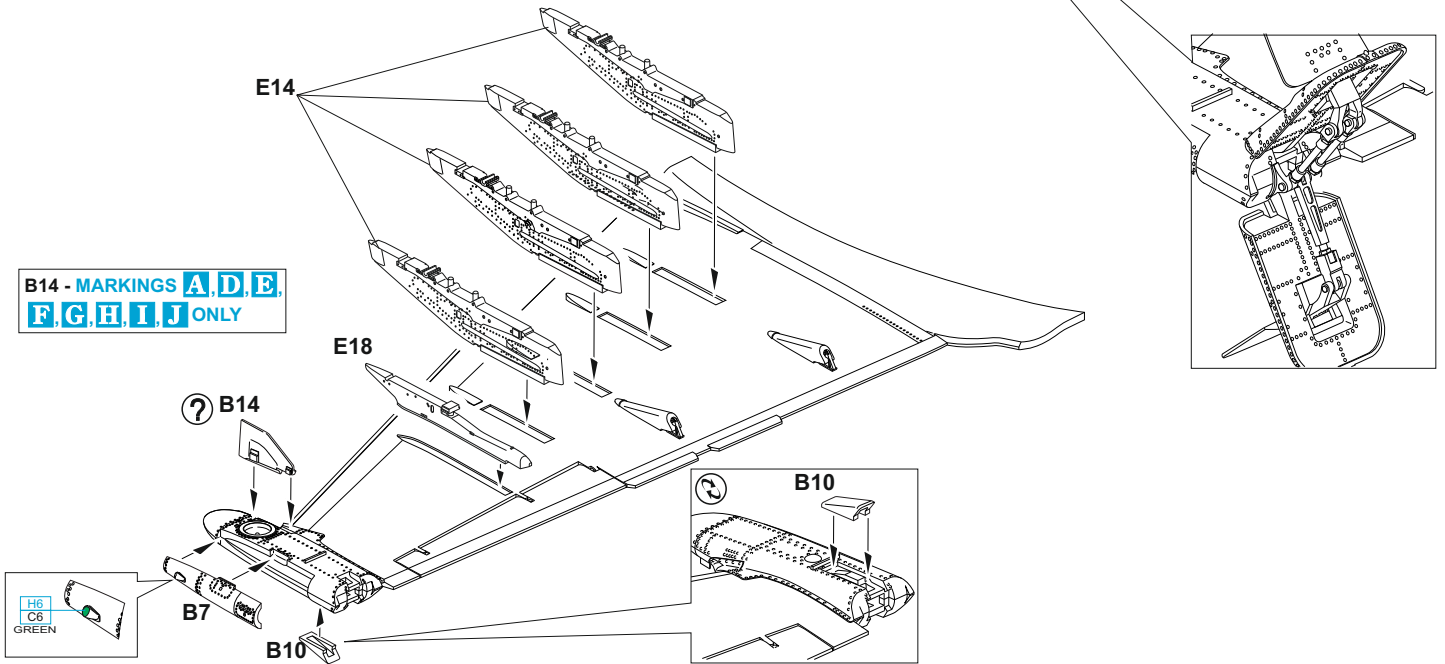

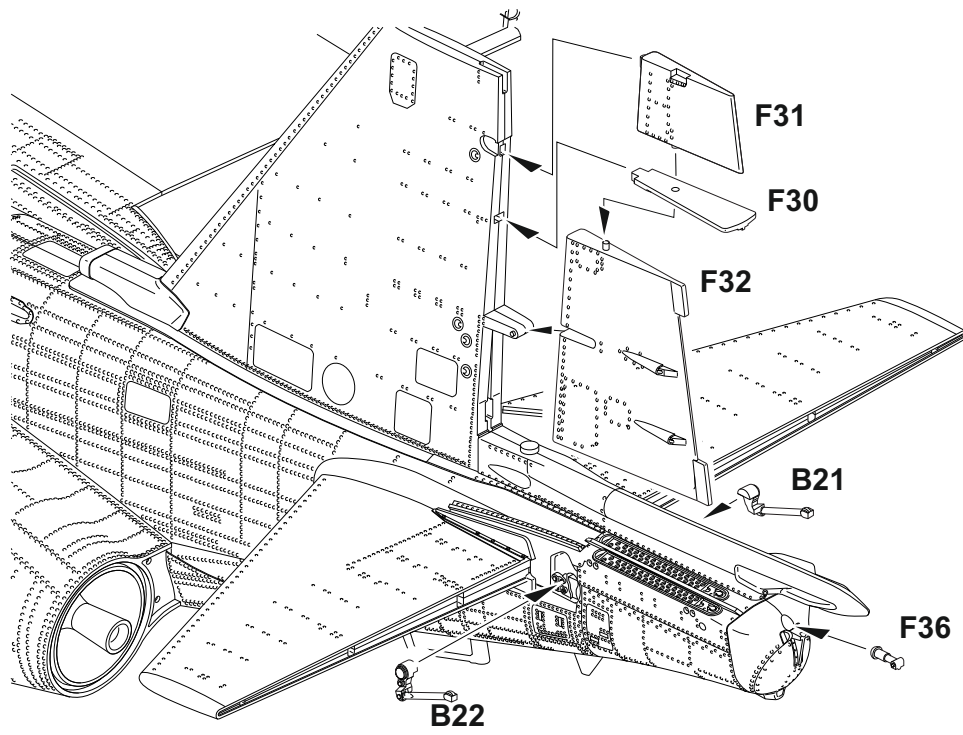

eduard
BRASSIN

R12

R12

eduard
BRASSIN

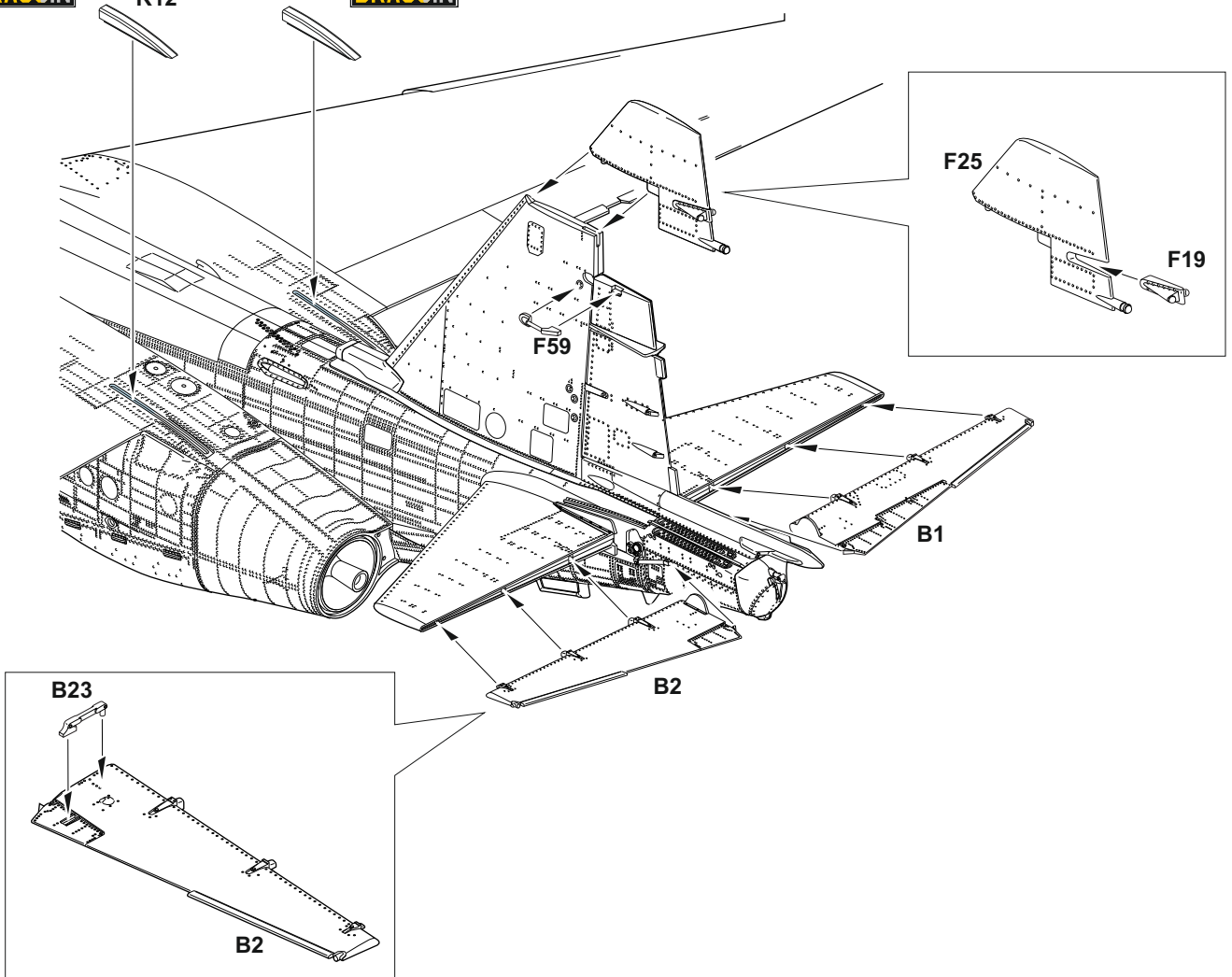

F25

F19

F59

B1

B2

B23

B2

eduard BRASSIN

R4 **R5**

H77 C137 TIRE BLACK

H26 C66 BRIGHT GREEN

R6 **R8**

H77 C137 TIRE BLACK

H26 C66 BRIGHT GREEN

H12 C33 FLAT BLACK

H26 C66 BRIGHT GREEN

H57 C73 AIRCRAFT GRAY

H77 C137 TIRE BLACK

PE51 **H26 C66 BRIGHT GREEN**

R8 - MARKINGS B, C ONLY

N **O** **P**

R5 **R4**

B26 **B20**

H70 C60 RLM 02 GRAY

B27 **B19**

H70 C60 RLM 02 GRAY

C30 **F49** **E26**

H70 C60 RLM 02 GRAY

H338 C338 LIGHT GRAY

N

B26 **B20**

H70 C60 RLM 02 GRAY

O

B27 **B19**

H70 C60 RLM 02 GRAY

Q

K11 **K12** **K10** **K9**

H33 C81 RUSSET

H12 C33 FLAT BLACK

H338 C338 LIGHT GRAY

R For painting of the external tanks follow the corresponding camouflage scheme

E7 **E13**

MARKINGS B, C

PE7 **PE58** **PE59** **PE68**

H12 C33 FLAT BLACK

MARKINGS A, D, E, F, G, H, I, J

PE23 **PE61** **PE58**

H26 C66 BRIGHT GREEN

H26 C325 GRAY

D1 **F22** **F26** **F13**

H26 C66 BRIGHT GREEN

F26

H325 C325 GRAY

"ES" marked decal for individual aircraft

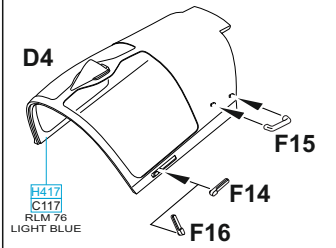
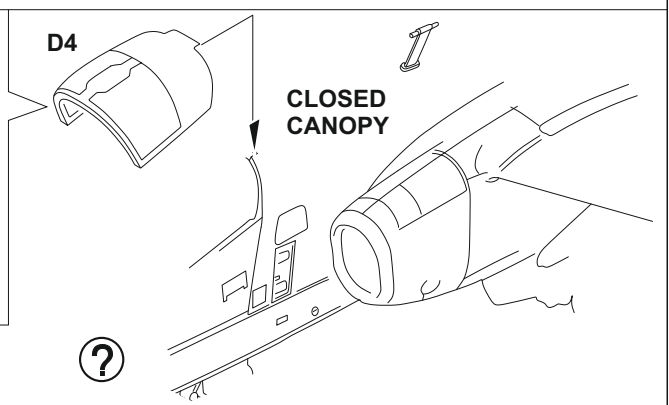
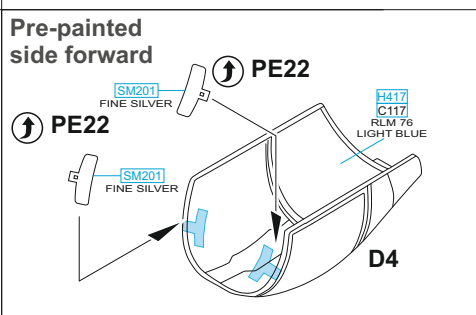
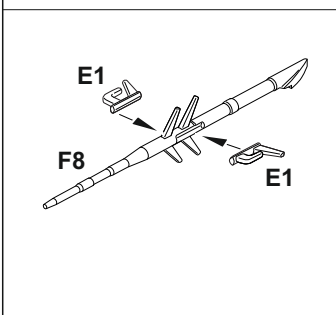
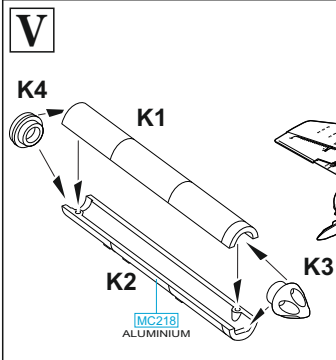
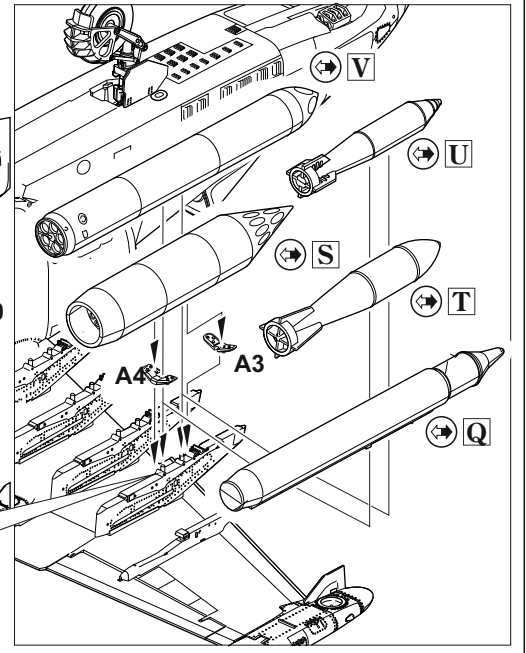
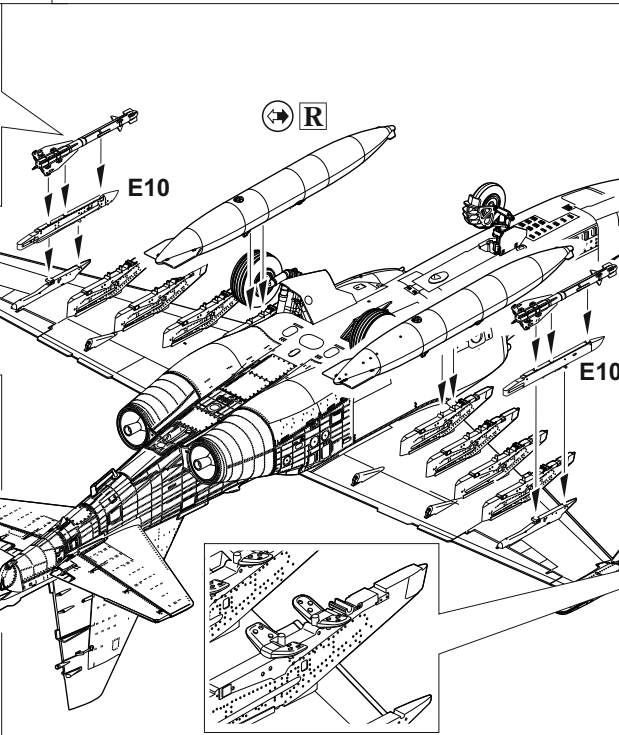
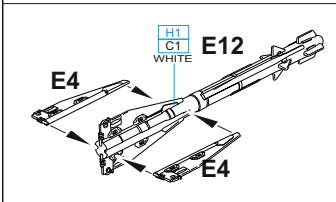
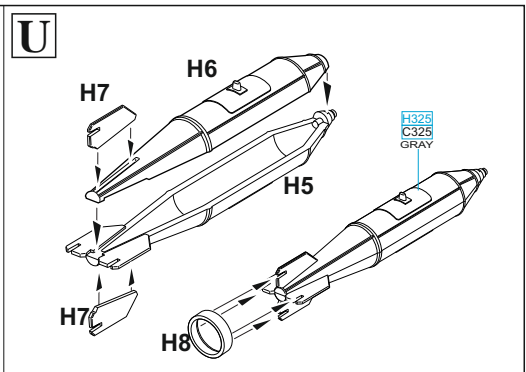
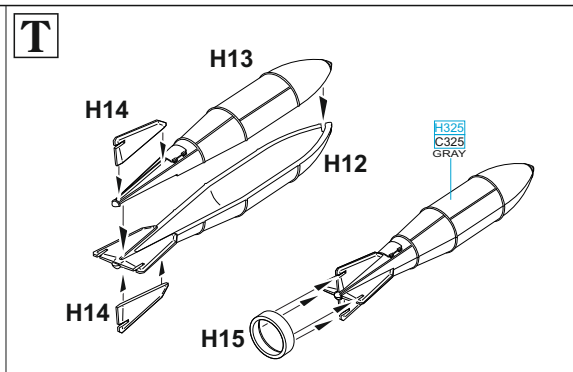
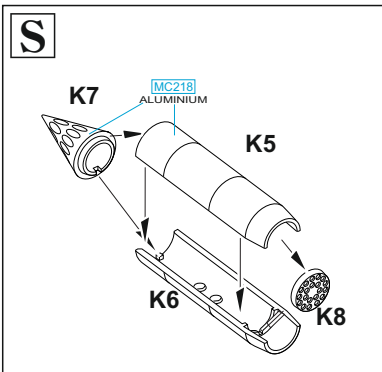

F5 - MARKINGS **A, D, E, F, G, H, I, J**
R13 - MARKINGS **B, C**

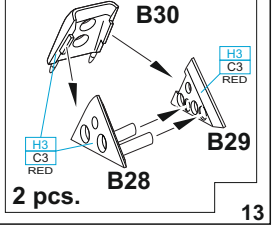
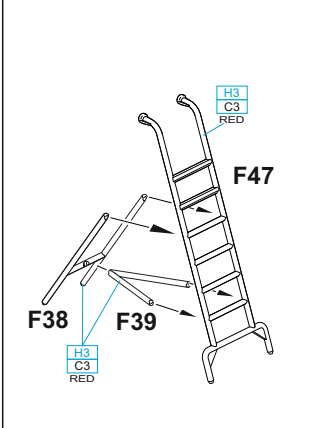
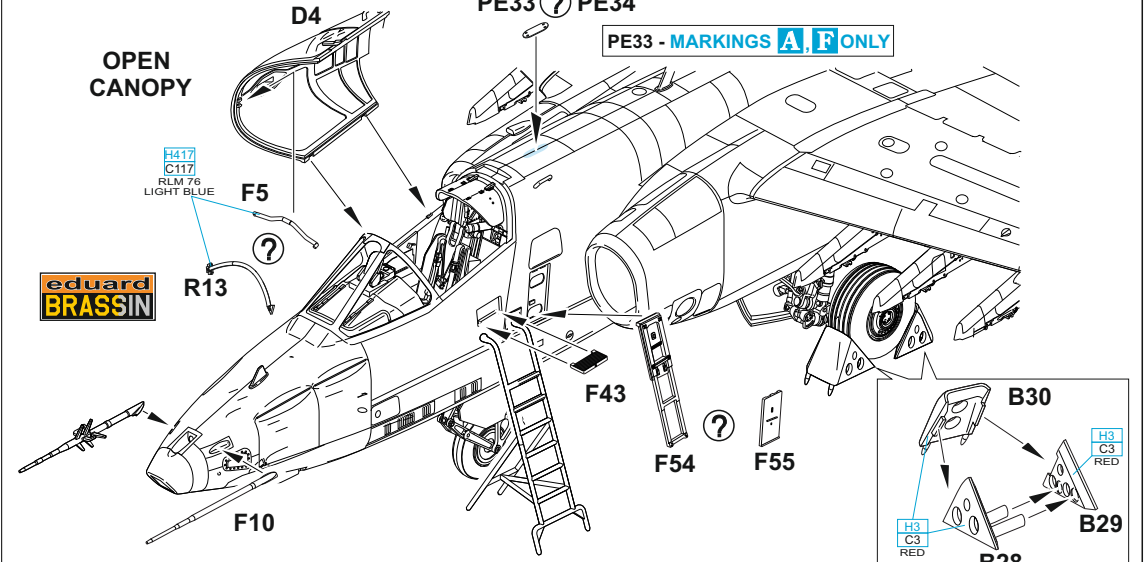

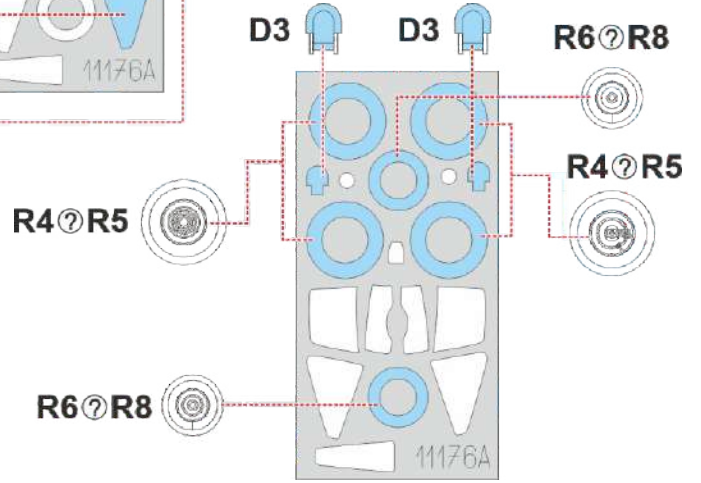
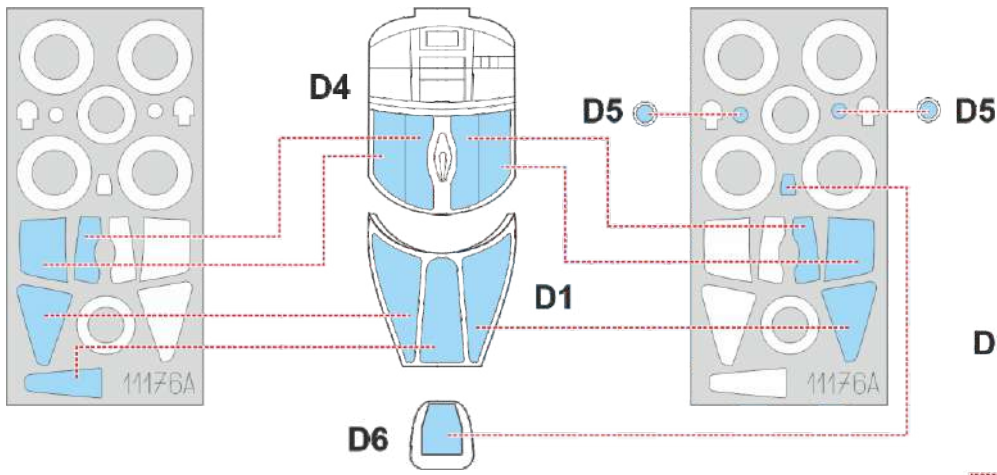

Su-25

PTB-800 – Russian stencils

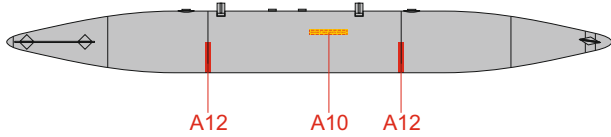
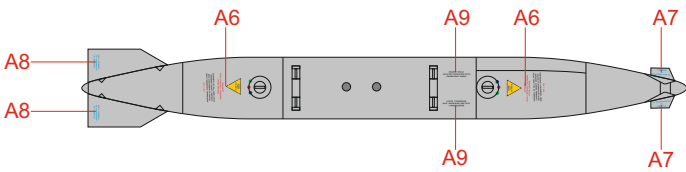
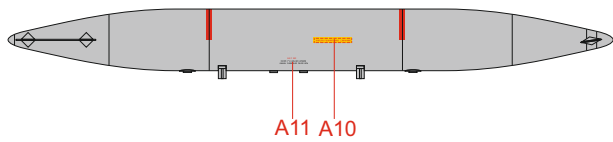

PTB-800 – Slovak stencils

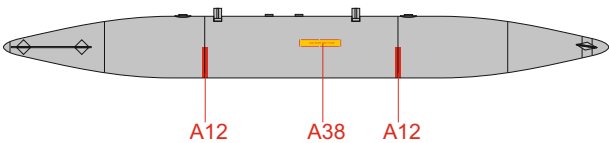
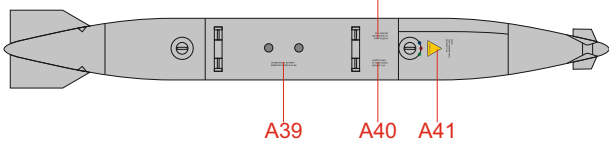
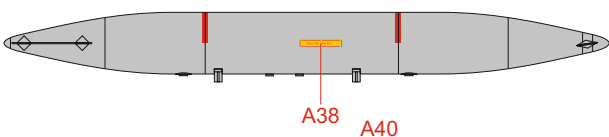

S-25 OFM

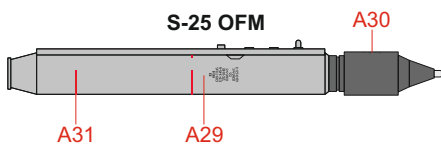

FAB 500 M62

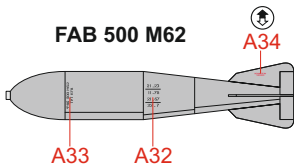

**RBK-250
PTAB-2.5**

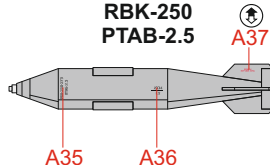

APU-60

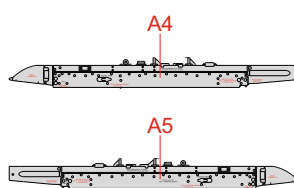

R-60

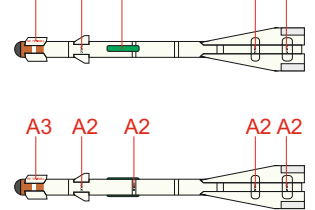

B-8

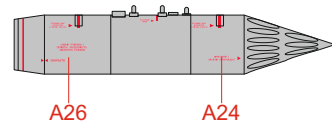
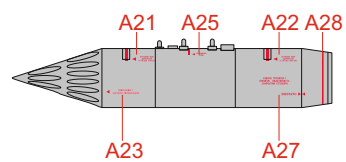

B-13

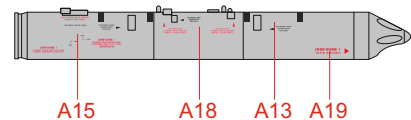
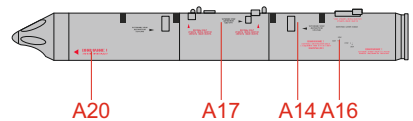

STENCILING POSITIONS

In the summer of 1991, the most interesting Czech Su-25K in terms of coloration was the aircraft number 9013. The unusual color scheme with a painting of a frog destroying a tank by a hammer was based on the NATO code name of Su-25: Frogfoot. Arpád Molnár was the main person behind this design, the drawing of the frog was made by Ladislav Váňa. The aircraft was made famous thanks to numerous displays flown by major František Tabačko and later also by kpt. Martin Hejra. The color job was done with basic grey primer. While yellow paint was bought in a local drugstore and brown and both greens were the colors used for camouflage paints of the aircraft shelters and other buildings on the air base. The drawing of the frog was done with Humbrol paints using a modeler spray gun.

ČESKOU VERZI TEXTU NALEZNETE NA

www.eduard.com

POD KATALOGOVÝM ČÍSLEM 11176

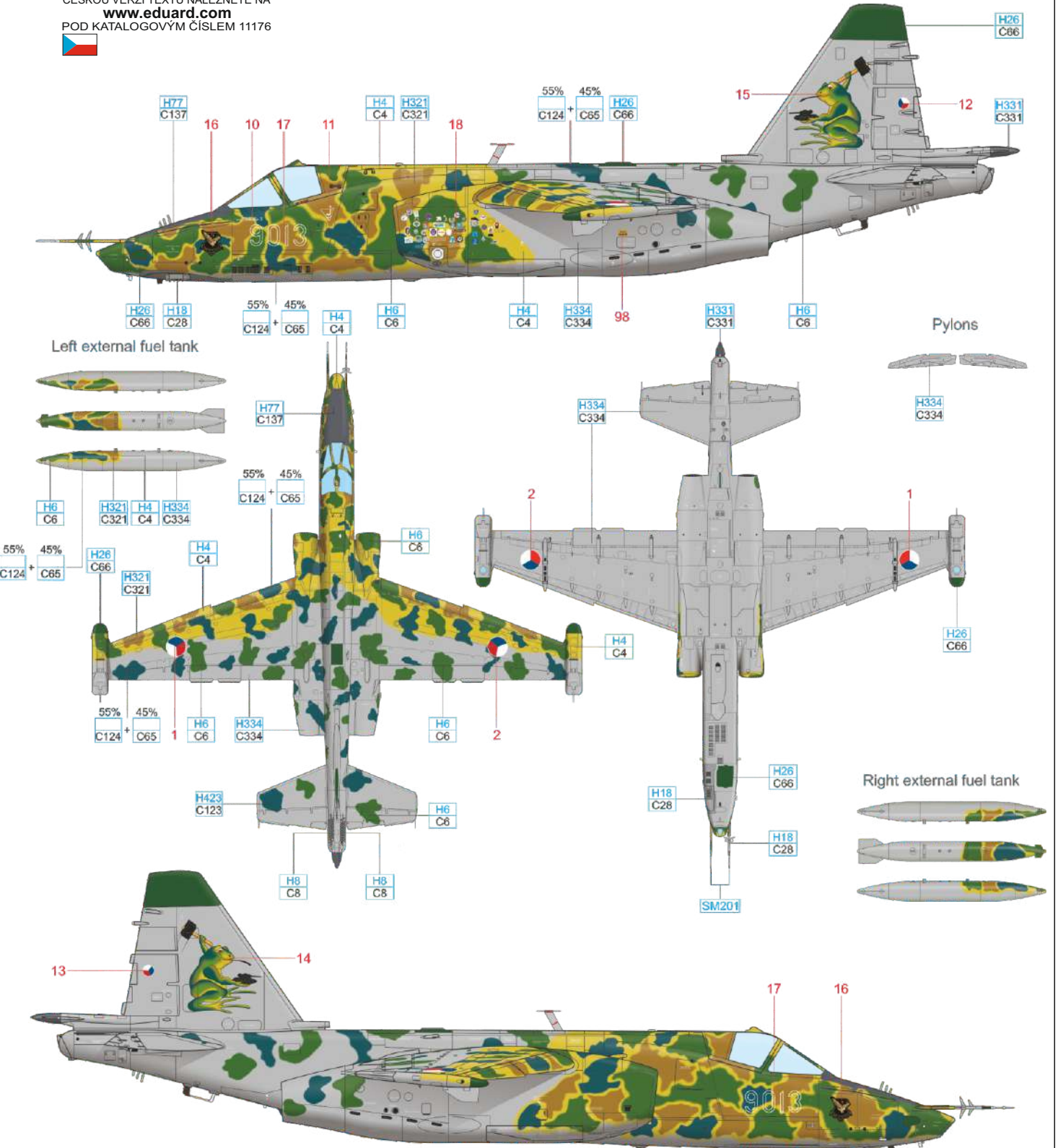

BRIGHT GREEN	H26	STEEL	H18	SILVER	H8	DARK SEAGRAY	H331	BRIGHT BLUE	C65	SUPER FINE SILVER 2	SM201
TIRE BLACK	H77	LIGHT GRAY	H334	YELLOW	H4	GREEN	H6	DARK GREEN	C124	LIGHT BROWN	H321
	C137		C334		C4		C6				C321

B 5007, 30 Fighter Bomber Regiment, Hradec Králové, Czechoslovakia, April 1984

One of the first delivery batch of eight Su-25Ks in their original form, i.e., with black fuselage numbers. The aircraft were delivered from the USSR with national insignia only, numbers were applied after acceptance by Czechoslovak Air Force. Aircraft of the series 5 and 6 were not equipped with lateral control boosters, i.e., control of the ailerons. Therefore, they were equipped with large trim tabs on the ailerons. The black fuselage numbers were difficult to read on the dark camouflage colors and were therefore outlined in white. Subsequently, they were painted in full white. While still with black number, the aircraft was shiny new and did not sport any signs of wear.

ČESKOU VERZI TEXTU NALEZNETE NA
www.eduard.com
 POD KATALOGOVÝM ČÍSLEM 11176

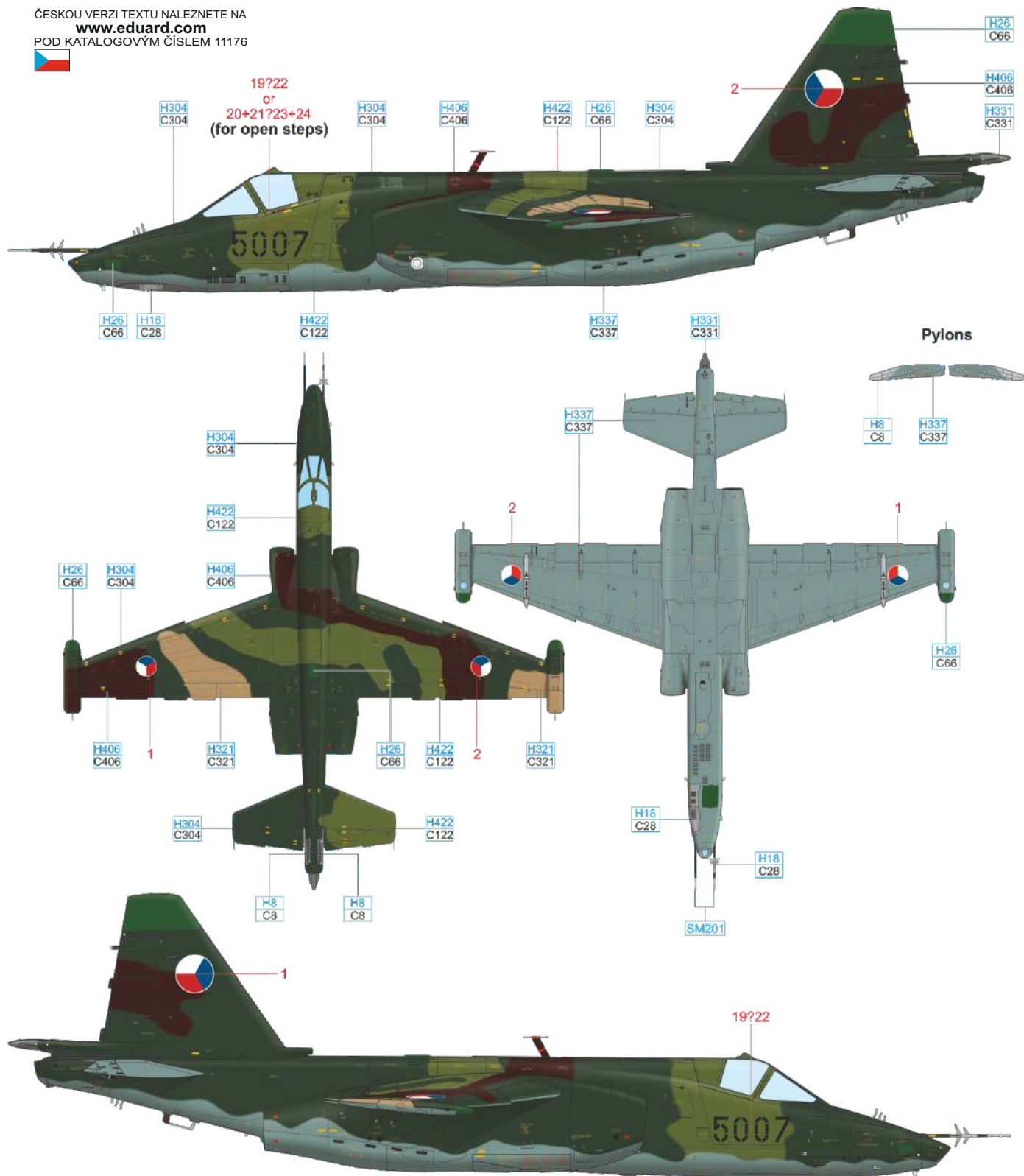

BRIGHT GREEN	H26 C66	STEEL	H18 C28	SILVER	H8 C8	DARK SEAGRAY	H331 C331	SUPER FINE SILVER 2	SM201
GRAYISH BLUE	H337 C337	OLIVE DRAB	H304 C304	GREEN	H422 C122	LIGHT BROWN	H321 C321	BROWN	H406 C406

C 6019, 30 Attack Aviation Regiment, Pardubice, Czechoslovakia, August 1988

Various nose arts appeared on the Czechoslovak Su-25Ks. The first attempts were just quickly and easily removable chalk drawings. Such a drawing, the silhouette of a seated girl with a screwdriver, was sketched on this aircraft as well, and as there were no objections from the commanding officers, it was decided to paint colorful and more durable nose art. Aircraft engineer Antonín Fidranský decided to create a drawing of a girl and a shark's mouth by washable colors. Also, the emblem of the 30 Attack Aviation Regiment, last used on the MiG-15bisSB, appeared on this aircraft. The painting of "Anča" (Annie) as the aircraft was named, probably occurred on the weekend of August 20 and 21, 1988, just before the planned live ammunition gunnery exercise. But the taxiing accident of aircraft No. 1008 dashed any hope of getting the "Anča" into the air, because the incident was followed by the arrival of the AAIC (Aircraft Accident Inquiry Commission). Due to that, the paintwork was quickly washed out to avoid any unwanted interest from the AAIC. This aircraft was manufactured on October 18, 1984, and first flown in Czechoslovakia on January 18, 1985. The last flight was conducted on May 27, 1998. When discharged, the aircraft had 917 hrs logged and 15 mins of flight time. After its retirement it was sold to the USA on April 10, 2004.

ČESKOU VERZI TEXTU NALEZNETE NA
www.eduard.com
 POD KATALOGOVÝM ČÍSLEM 11176

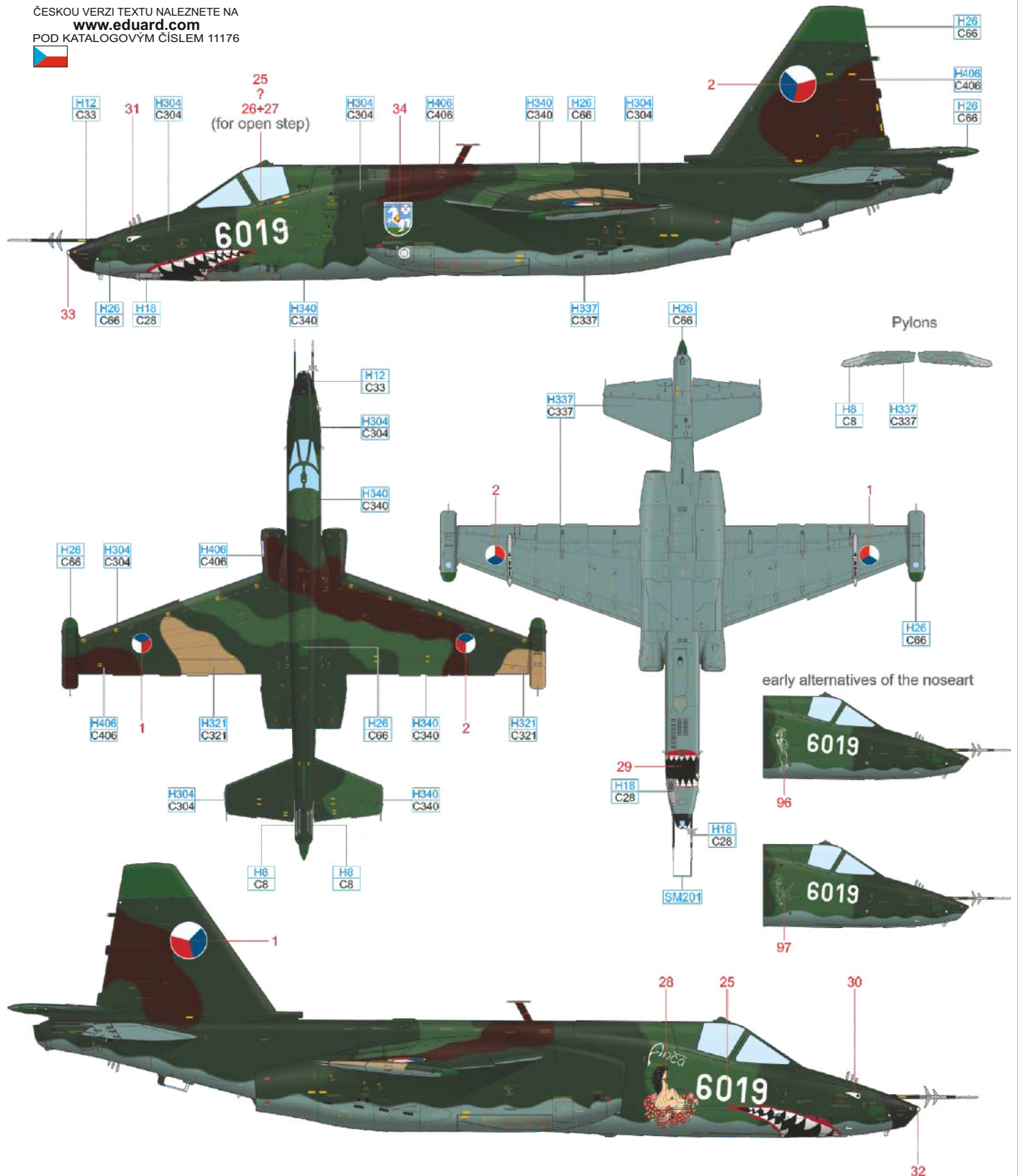

BRIGHT GREEN	H26 C66	STEEL	H18 C28	SILVER	H8 C8	FLAT BLACK	H12 C33	SUPER FINE SILVER 2	SM201
GRAYISH BLUE	H337 C337	OLIVE DRAB	H304 C304	FIELD GREEN	H340 C340	LIGHT BROWN	H321 C321	BROWN	H406 C406

D 1002, 30 Attack Aviation Regiment, Pardubice, Czech Republic, May 1993

Aircraft of fuselage number 1002 changed its camouflage and markings several times. In May 1993, it underwent a revision of R-1 level at the Čáslav Aircraft Repair Base and a distinctive shark's mouth, red trim on the white fuselage number and a large 30 Attack Aviation Regiment inscription on the directional stabilizer were applied. Less than a year later, the entire vertical fin and rudder were painted in tricolor livery with Lubrifilm company advertisement. This Su-25K was manufactured in Tbilisi on May 15, 1987, and landed at the Pardubice base on June 27 of the same year. It was one of the aircraft that were transferred to the air base in Náměšť in 1994. In 1996 it was overhauled and discharged in 2001 after a total flight time of 703 hrs and 43 mins. The aircraft was sold to a new user in 2003.

ČESKOU VERZI TEXTU NALEZNETE NA
www.eduard.com
 POD KATALOGOVÝM ČÍSLEM 11176

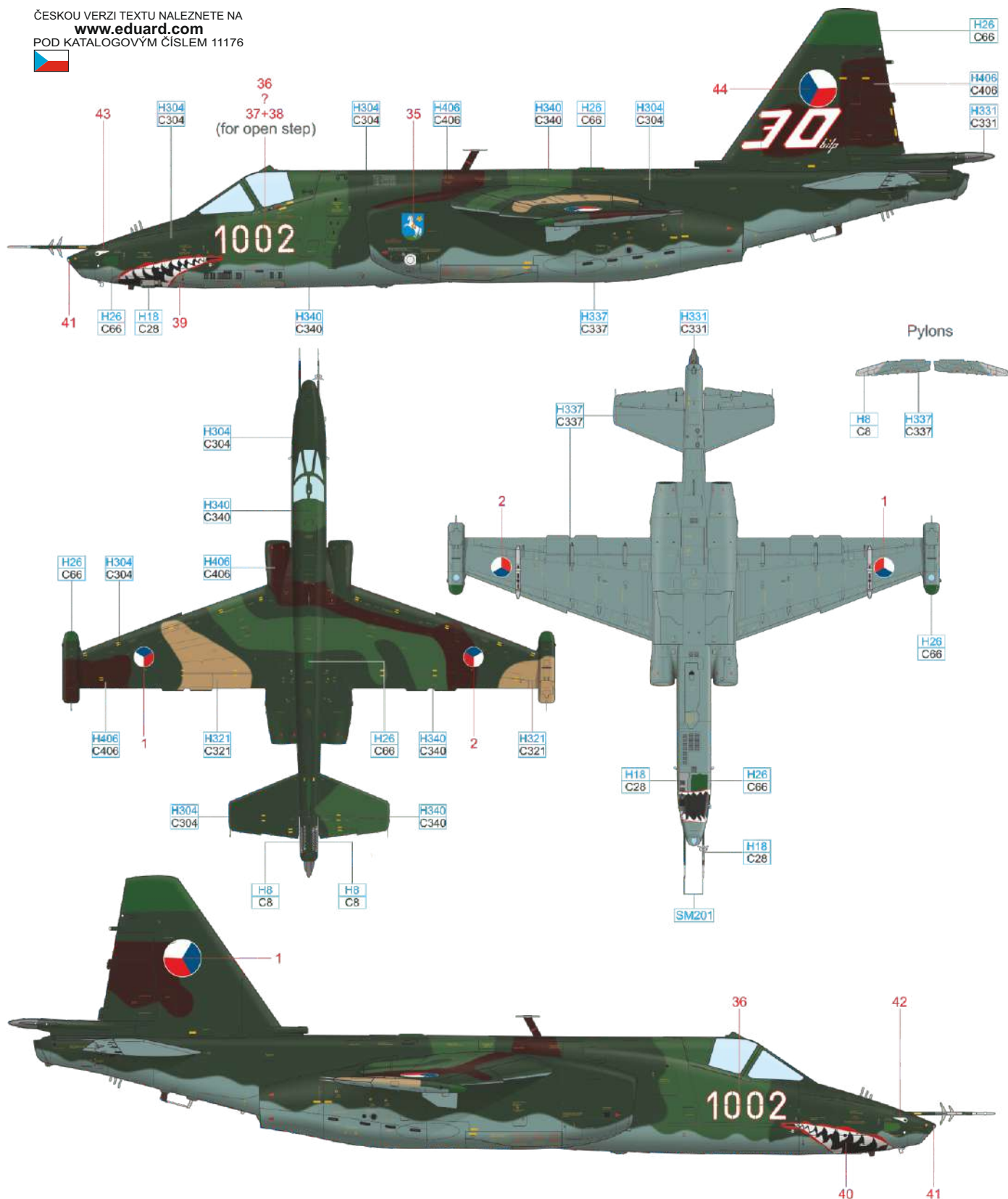

BRIGHT GREEN	H26 C66	STEEL	H18 C28	SILVER	H8 C8	DARK SEAGRAY	H331 C331	SUPER FINE SILVER 2	SM201
GRAYISH BLUE	H337 C337	OLIVE DRAB	H304 C304	FIELD GREEN	H340 C340	LIGHT BROWN	H321 C321	BROWN	H406 C406

The lack of funds for participation on the airshows was solved by the Display Team members by sponsorship. One of the aircraft "decorated" with sponsor's decals was Su-25K No. 1002, whose display "sorties" were supported by Lubrifilm company. The No. 8077 aircraft was similarly modified. The spraying and painting of the 1002 had its premiere during Pardubice airshow on May 21, 1994. The next 1002 appearance took place at the Aviation Days in Náměšť nad Oslavou on June 11 and in České Budějovice a week later, on June 18, 1994. Not everyone liked such a sponsorship and after interpellations from politicians, the Minister of Defense banned all advertising activities on military aircraft. Therefore, in July 1994, the advertising stickers were removed, leaving only the colored SOP. The 1002 flew in this design until the end of 1994. To finish Your model in this state of markings, do not use No. 45 decal and use Nos. 48; 49; 107; 108 for the tail vertical surfaces.

ČESKOU VERZI TEXTU NALEZNETE NA
www.eduard.com
 POD KATALOGOVÝM ČÍSLEM 11176



ATTENTION! Apply No. 45 decals only
 in conjunction with Nos. 46; 47; 105; 106 decals

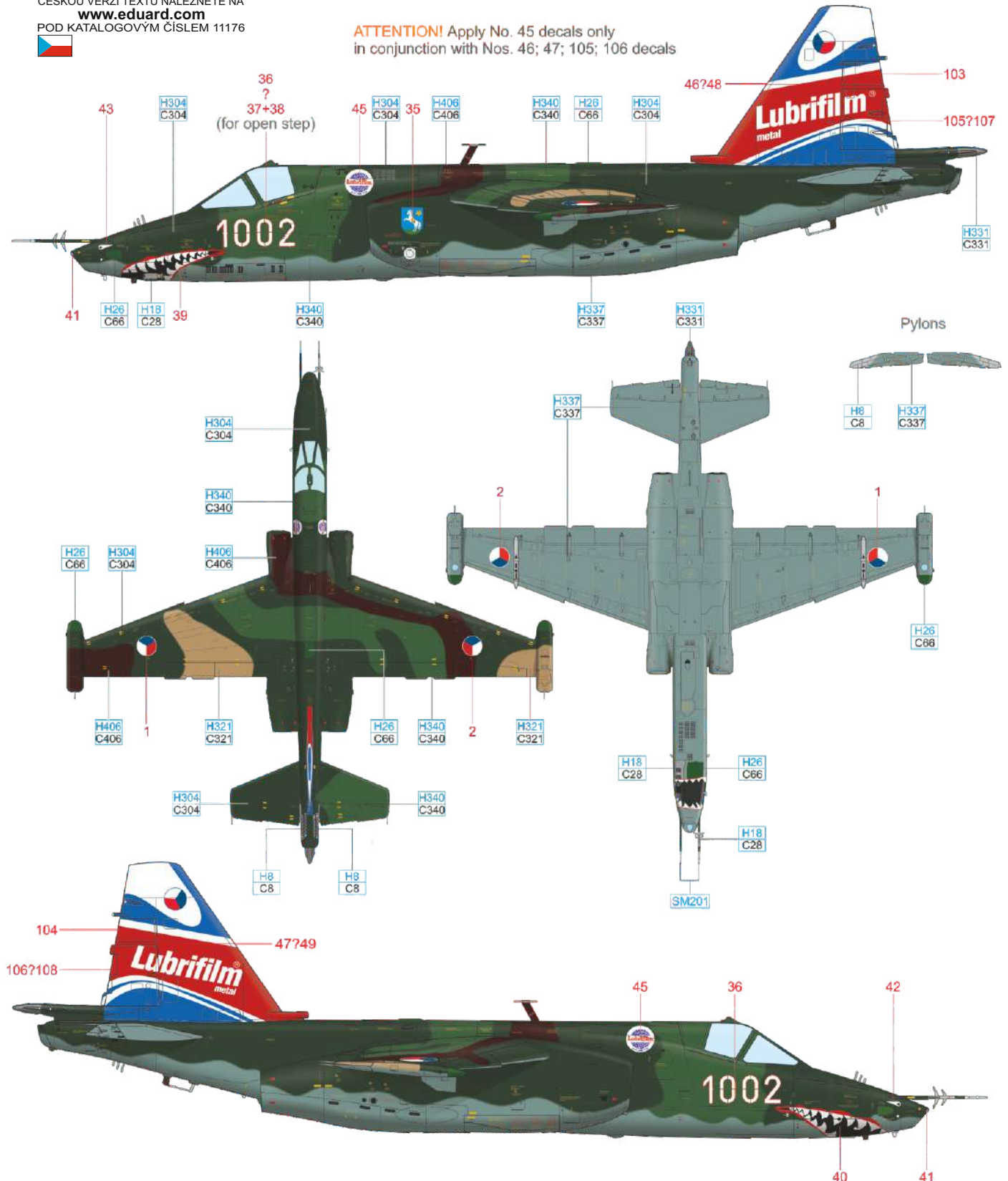

BRIGHT GREEN	H26 C66	STEEL	H18 C28	SILVER	H8 C8	DARK SEAGRAY	H331 C331	SUPER FINE SILVER 2	SM201
GRAYISH BLUE	H337 C337	OLIVE DRAB	H304 C304	FIELD GREEN	H340 C340	LIGHT BROWN	H321 C321	BROWN	H406 C406

The next reincarnation of the Su-25K number 1002 was named "Shark". Already at the end of 1995, the technicians of the 322 Squadron expressed their wish to have the fuselages of the two aircraft painted in a special color scheme, and Jan Martinec began to prepare graphic designs. The painting was carried out in the week from May 13 to 17, 1996, and finally the new coloring was applied on whole aircraft. The ceremonial roll out took place on Friday May 17, 1996 and the aircraft subsequently made number of displays. Kpt. Ladislav Oslanský flew it at CIAF 2000, which was the last display of the aircraft on domestic airshows.

ČESKOU VERZI TEXTU NALEZNETE NA
www.eduard.com
 POD KATALOGOVÝM ČÍSLEM 11176

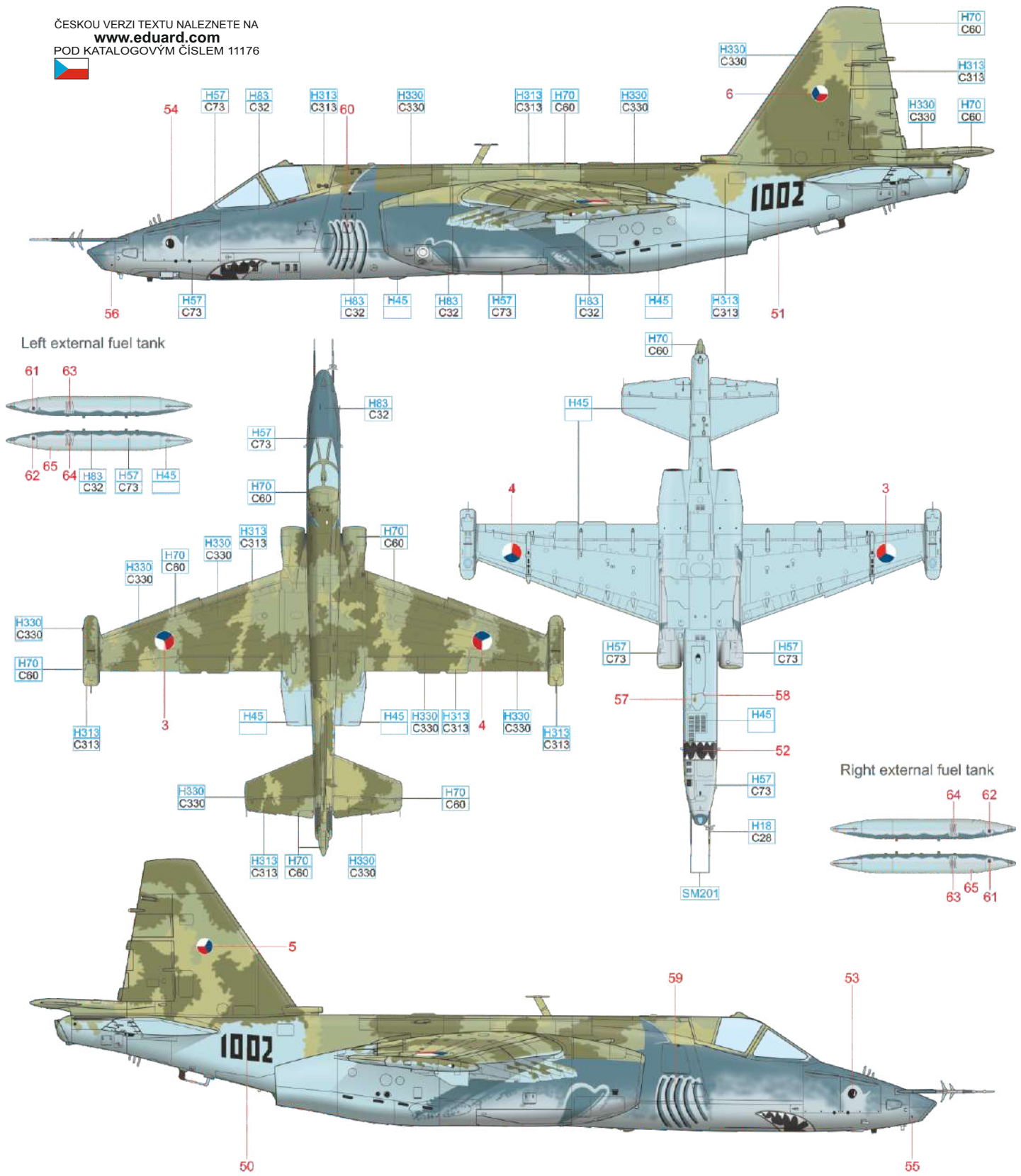

STEEL H18 C28 SUPER FINE SILVER 2 SM201

LIGHT BLUE H45 AIRCRAFT GRAY H57 C73 GRAY DARK H83 C32 RLM 02 H70 C60 YELLOW H313 C313 DARK GREEN H330 C330

Along with the 1002, the 8076 was also painted in a special livery. In its case, it was an application of the eagle motif that the 322 TS had as its emblem. The implementation of this coloring took only three days from May 15 to 17. The aircraft had the original camouflage in good condition and so received only the nose paint job and, as was customary, the auxiliary tanks were also decorated accordingly.

ČESKOU VERZI TEXTU NALEZNETE NA
www.eduard.com
POD KATALOGOVÝM ČÍSLEM 11176

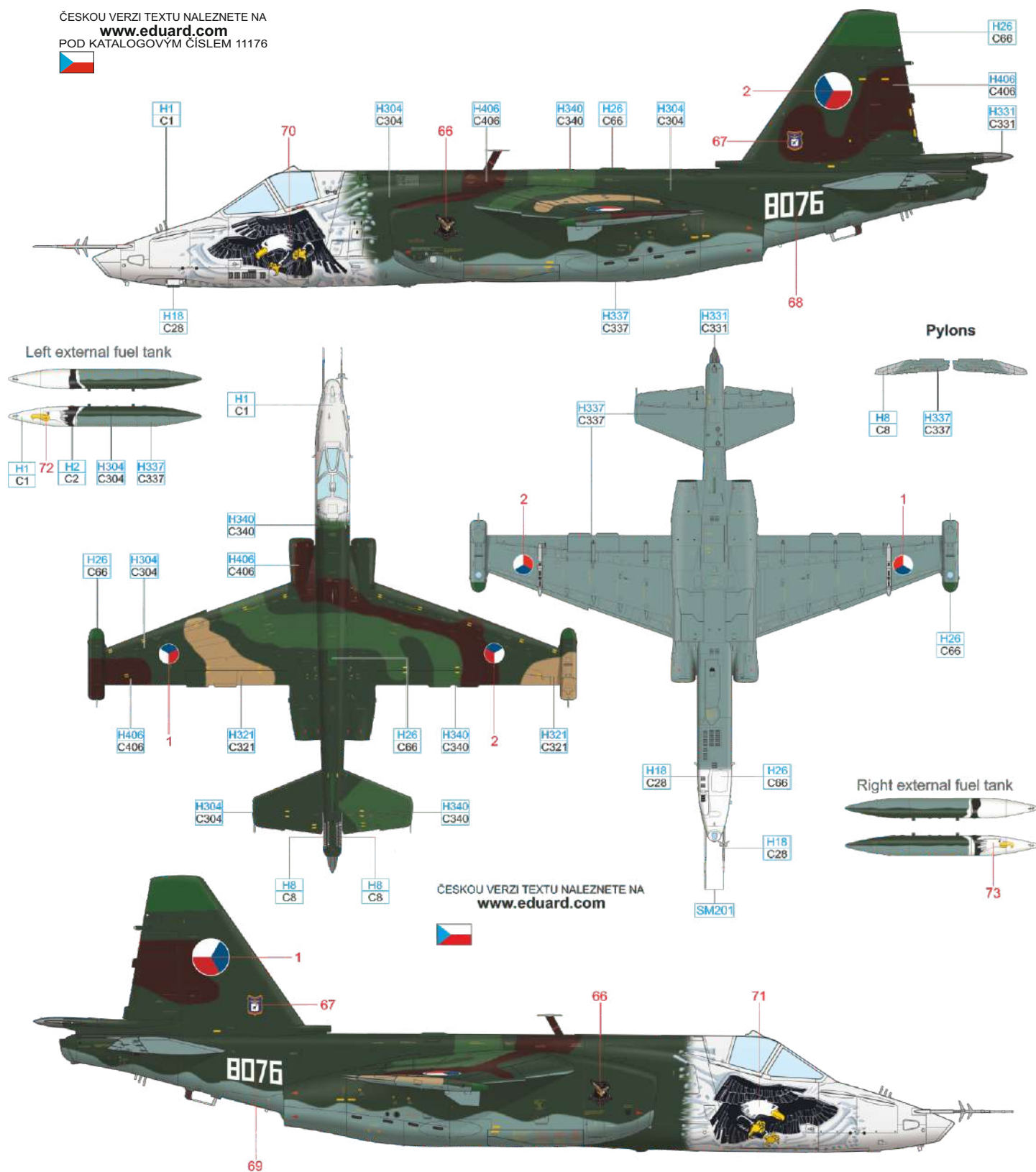

ČESKOU VERZI TEXTU NALEZNETE NA
www.eduard.com



WHITE	H1 C1	BLACK	H2 C2				
BRIGHT GREEN	H26 C66	STEEL	H18 C28	SILVER	H8 C8	DARK SEAGRAY	H331 C331
GRAYISH BLUE	H337 C337	OLIVE DRAB	H304 C304	FIELD GREEN	H340 C340	LIGHT BROWN	H321 C321
						BROWN	H406 C406
							SUPER FINE SILVER 2 SM201

Aircraft of the 322 Tactical Squadron gradually received graphic symbols on their vertical fins, which helped to identify the aircraft quickly even if the fuselage number was not visible. The number 8080 received two crossed white stripes on the green plastic cover of the top of the fin. The front sides of the engine nacelles already sported the squadron insignia with a stylized eagle. The colors were already very weathered.

ČESKOU VERZI TEXTU NALEZNETE NA
www.eduard.com
 POD KATALOGOVÝM ČÍSLEM 11176



Note heavily weathered colors

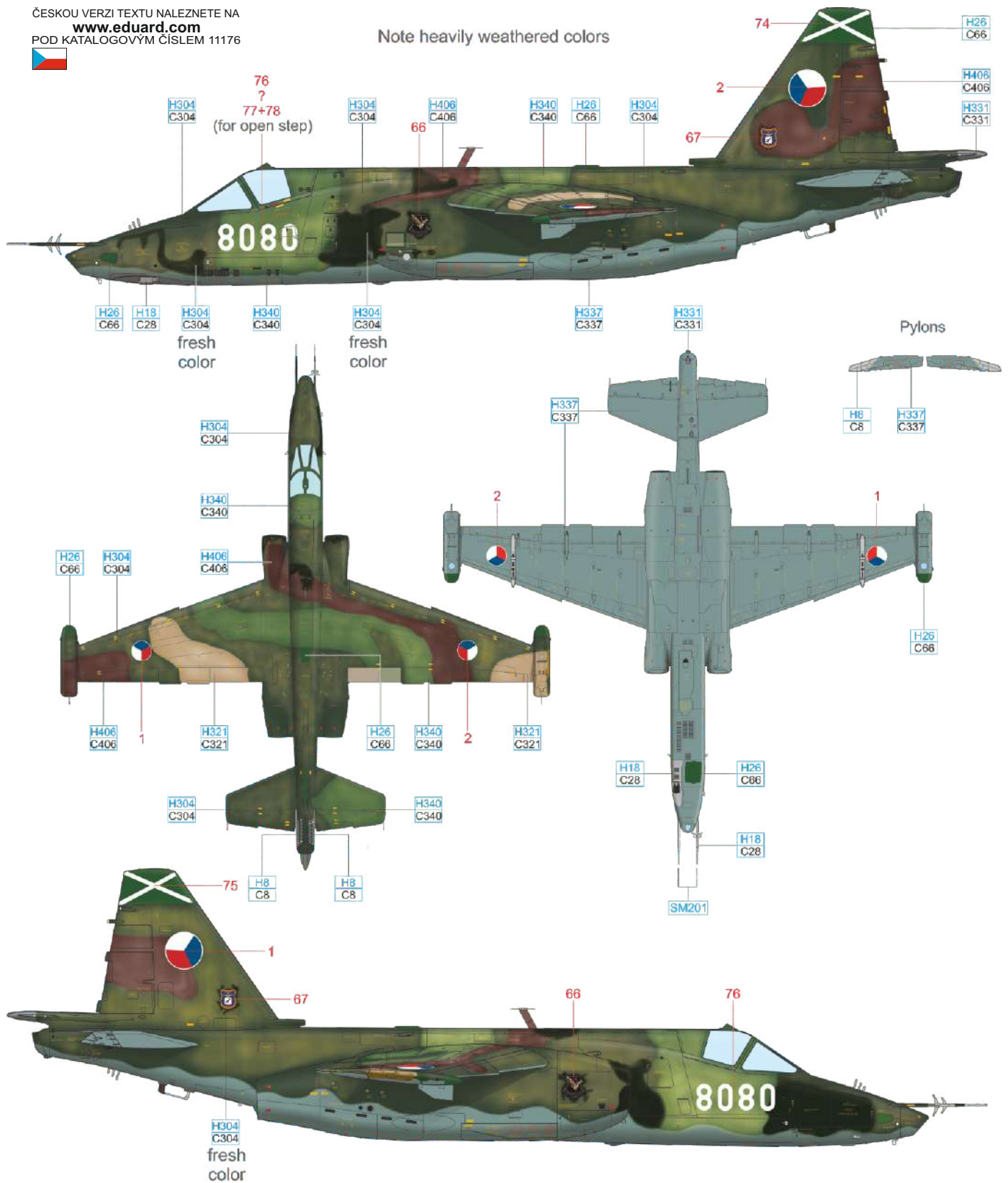

BRIGHT GREEN	H26 C66	STEEL	H18 C28	SILVER	H8 C8	DARK SEAGRAY	H331 C331	SUPER FINE SILVER 2	SM201
GRAYISH BLUE	H337 C337	OLIVE DRAB	H304 C304	FIELD GREEN	H340 C340	LIGHT BROWN	H321 C321	BROWN	H406 C406

In 1993, the 8074 was fitted with a "fire" motif that earned it the nickname "Flamingo". It was first presented to the public in this form at the 1993 SIAF Air Show in Košice. After the division of the Czechoslovakia, the newly formed 3 Fighter Bomber Aviation Regiment of the Slovak Air Force had its base at the Kuchyňa airfield, but since it was already occupied by MiG-21, Su-22 and L-29 aircraft, the Su-25Ks were based at the Trenčín airport, right next to the aircraft repair facilities. On January 1, 1993, the Su-25 squadron was reorganized and transferred to the 2 Combined Aviation Regiment in Piešťany, becoming its 1 squadron. It moved from Trenčín to Kuchyňa airfield on September 27, 1994 and became the 2 squadron of the 33 Fighter Bomber Wing Malacky on January 1, 1995 in the process of the second reorganization.

ČESKOU VERZI TEXTU NALEZNETE NA
www.eduard.com
 POD KATALOGOVÝM ČÍSLEM 11176

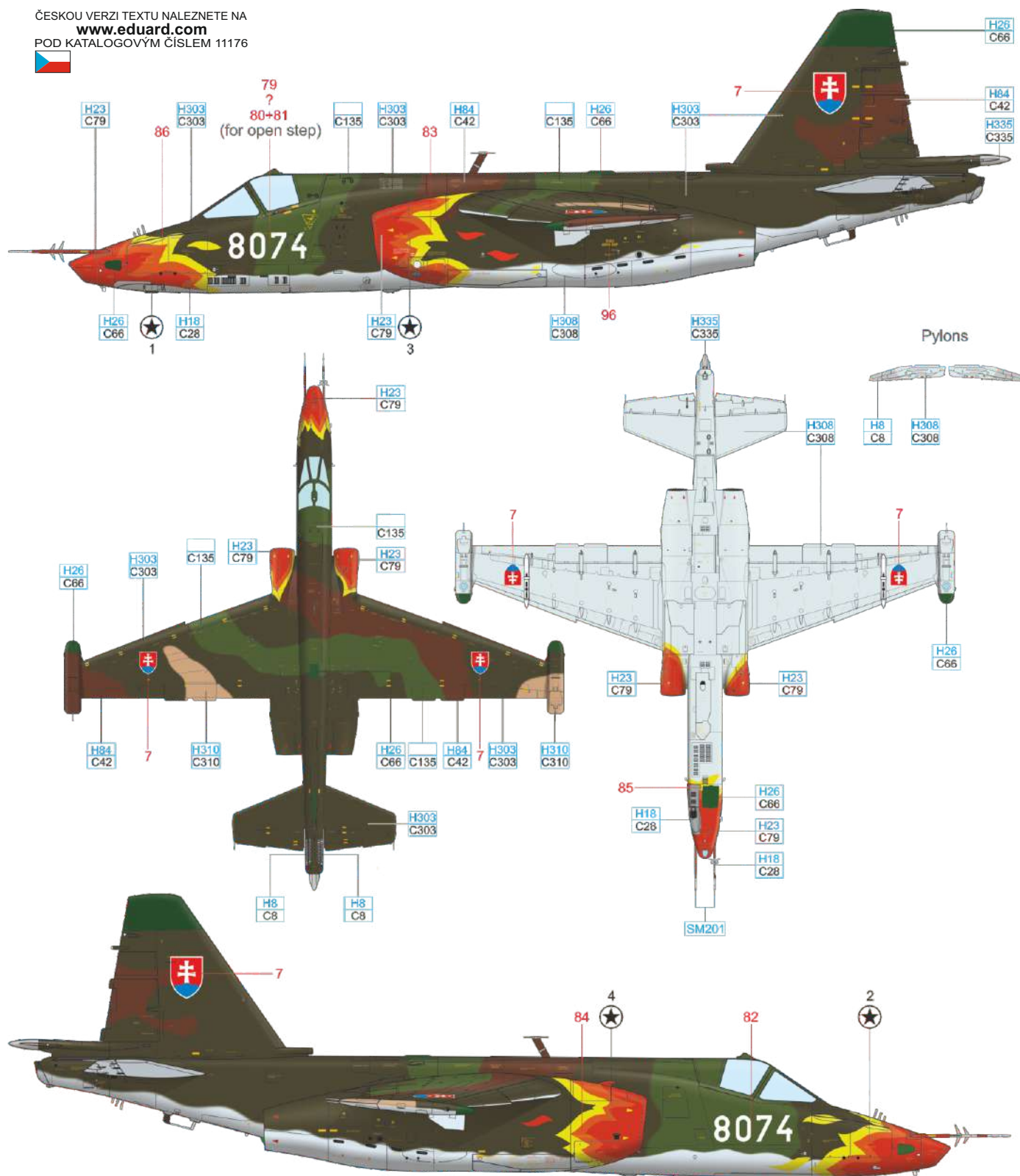

BRIGHT GREEN	H26 C66	STEEL	H18 C28	SILVER	H8 C8	MEDIUM SEAGRAY	H335 C335	SUPER FINE SILVER 2	SM201
SHINE RED	H23 C79	GREEN	C135	GREEN	H303 C303	BROWN	H310 C310	MAHOGANY	H84 C42
								GRAY	H308 C308

J 1027, 3 Fighter Bomber Regiment, Trenčín airfield, Slovakia, August 1994

The Slovak Su-25K named "Bizon" (Buffalo) became the most attractively colored Slovak aircraft of the type. The design was created by Pavol Homer and Jozef Horváth. Preparations started on July 17, 1994 and the "Bizon" flew for the first time on July 28 and 29 with the unfinished paint job. It was completed on August 14 and it was presented in premiere at the SIAF 1994 Air Show on August 21 in Bratislava. The "Bizon" was the only Su-25 that also bore the emblem of the 1 Technical Squadron. After completing its service in the Slovak Air Force, the aircraft was sold in 2004 to Armenia.

ČESKOU VERZI TEXTU NALEZNETE NA
www.eduard.com
 POD KATALOGOVÝM ČÍSLEM 11176

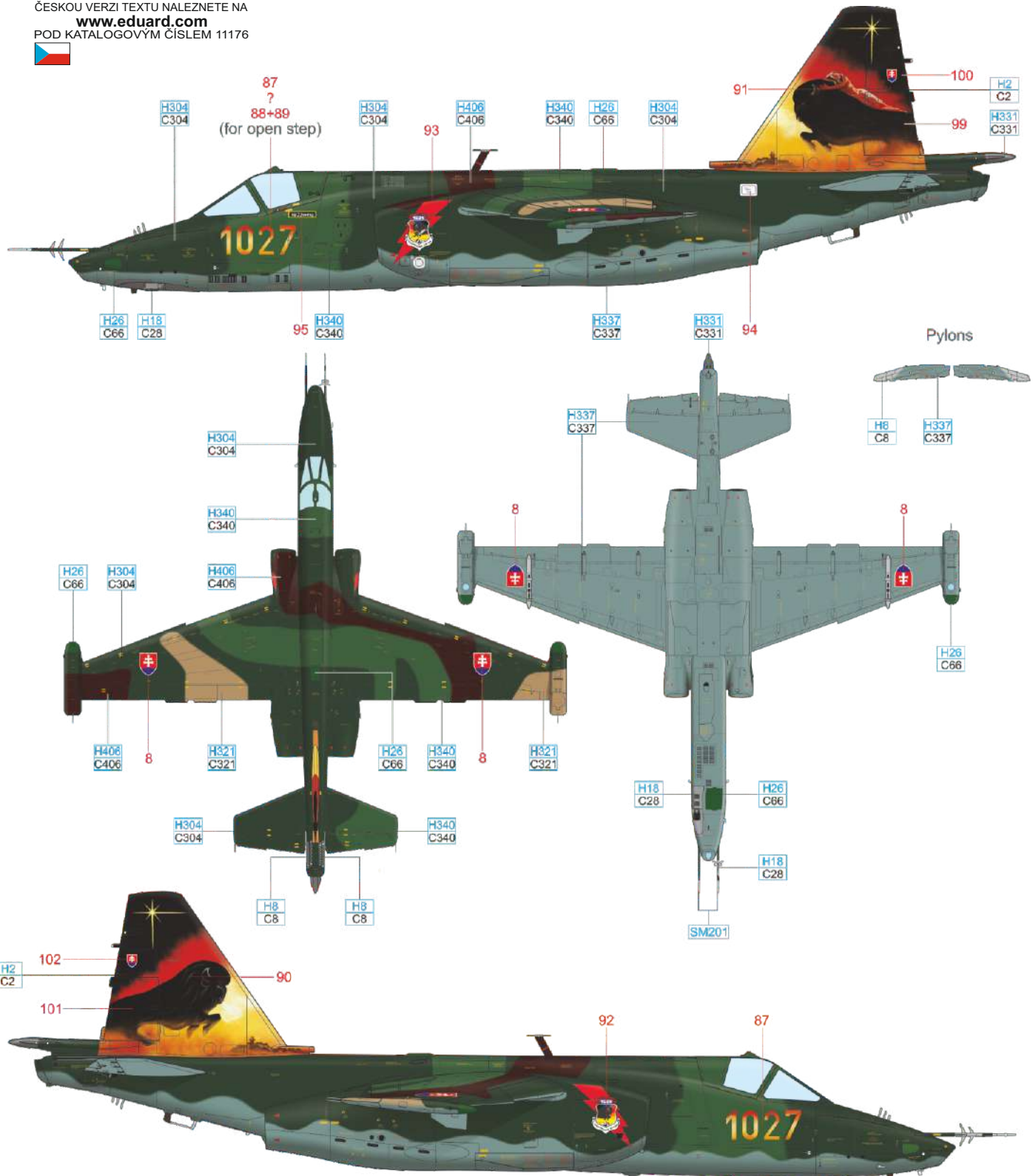

BRIGHT GREEN	H26 C66	STEEL	H18 C28	SILVER	H8 C8	DARK SEAGRAY	H331 C331	SUPER FINE SILVER 2	SM201
GRAYISH BLUE	H337 C337	OLIVE DRAB	H304 C304	FIELD GREEN	H340 C340	LIGHT BROWN	H321 C321	BROWN	H406 C406
								BLACK	H2 C2

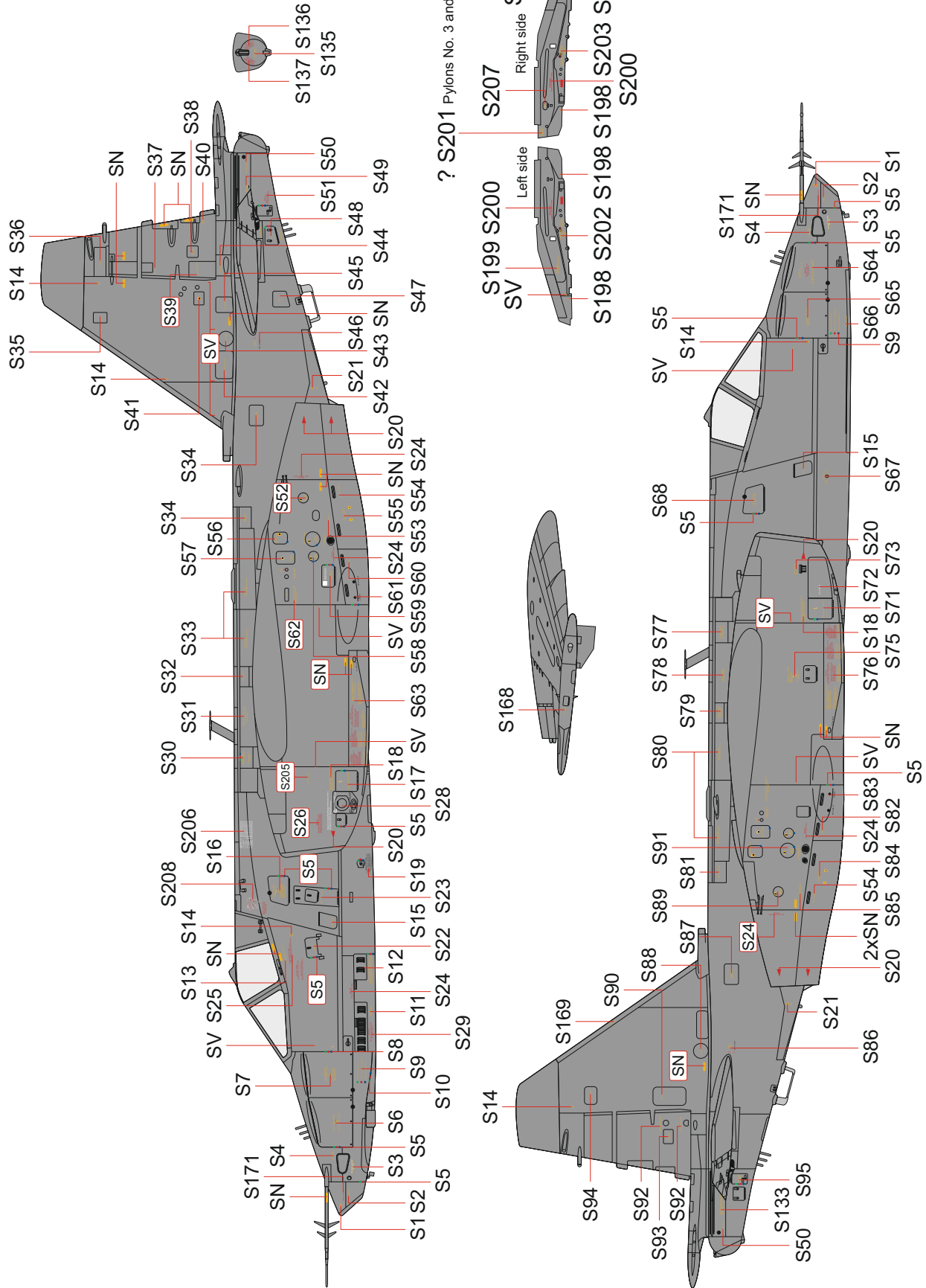

? S201 Pylons No. 3 and 9 only

