

MONOGRAM

KIT5980

85598000200

F4U-5 / 5NL CORSAIR

**PRO
MODELER**

Vought's F4U Corsair was one of the most successful fighter aircraft during World War II. When World War II ended, the jet age began in earnest; the Corsair was one of the very few propeller driven fighters to continue in development and production. The F4U-5 was the first version developed and flown after the war, and several sub-variants were produced. In addition to the basic F4U-5 fighter; these included the F4U-5N radar-equipped night fighter, and the F4U-5NL winterized night fighter. All sub-variants of the F4U-5 were powered by a Pratt & Whitney R-2800-32W radial engine with a two-stage, variable-speed supercharger. The

installation of this more powerful engine required that the forward fuselage be lengthened by ten inches, and two scoops were located in the cowl ring. Armament included four 20-mm cannons mounted in the wings, and eight optional rockets carried on stub pylons under the outer wing panels. Two bombs or external fuel tanks could be loaded on larger pylons under the center wing section. F4U-5s were used extensively in Korea as night fighters and ground attack aircraft. Lt. Guy Bordelon of VC-3 became the Navy's only night fighter ace, and the only ace to fly a propeller driven aircraft to shoot down five communist aircraft in an F4U-5N night fighter. The F4U-5NL differed from the F4U-5N in that it was winterized by the addition of deicing boots on the leading edges of the wings and tail surfaces. F4U-5N's and F4U-5NL's retained full attack capability of the F4U-5, the Navy and Marine squadrons often used them to attack ground targets in Korea. Your Revell-Monogram model comes with optional parts and markings to build an F4U-5NL from VC-4 or a standard F4U-5 from the Naval Reserve squadron at NAS Glenview, Illinois.



* REPEAT SEVERAL TIMES
* A REPETER PLUSIEURS FOIS



* OPTIONAL PARTS
* PIECES EN OPTION



* DECAL
* DECAL COMMANE



* ALTERNATIVE ASSEMBLY
* ENSEMBLAGE ALTERNATIVE



* CEMENT TOGETHER
* A COLLER



* REMOVE AND THROW AWAY
* A RETIRER ET JETER



* DO NOT CEMENT
* NE PAS COLLER

READ THIS BEFORE YOU BEGIN

- * Study the assembly drawings.
- * Each plastic part is identified by a number.
- * For better paint and decal adhesion, wash the plastic parts in a mild detergent solution. Rinse and let air dry.
- * Check the fit of each piece before cementing in place.
- * Use only cement for polystyrene plastic.
- * Scrape and paint from areas to be cemented.
- * Allow paint to dry thoroughly before handling parts.
- * Any unused parts may be discarded.

DECAL APPLICATION INSTRUCTIONS

1. Cut desired decal from sheet.
2. Dip decal in water for a few seconds.
3. Place wet decal on paper towel.
4. Wait until decal is movable on paper backing.
5. Place decal in position on model, face up and slide backing away.
6. Press out air bubbles with a soft damp cloth.
7. Milkiness that may appear is for better decal adhesion and will dry clear. Wipe away any excess adhesive.
8. Do not touch decal until fully dry.
9. Allow the decals 48 hours to dry before applying clear coat.

NOTE: Decals are compatible with setting solutions or solvents.

LIRE CE QUI SUIT AVANT DE COMMENCER

- * Etudier les schémas de montage.
- * Chaque pièce en plastique est identifiée par un numéro.
- * Pour une meilleure prise de la peinture et des autocollants, laver les pièces en plastique avec une solution détergente peu concentrée. Les rincer et les laisser sécher à l'air.
- * Vérifier que chaque pièce s'ajuste bien avant de la coller en place.
- * N'utiliser que de la colle pour polystyrène.
- * Gratter les parties à coller pour enlever la peinture.
- * Laisser la peinture bien sécher avant de manipuler les pièces.
- * Toute pièce inutilisée peut être jetée.

DIRECTIVES D'APPLICATION DES AUTOCOLLANTS

1. Découper l'autocollant désiré de la feuille.
2. Tremper l'autocollant dans de l'eau pendant quelques secondes.
3. Placer l'autocollant mouillé sur une serviette en papier.
4. Attendez que l'autocollant puisse être déplacé sur son support en papier.
5. Mettre l'autocollant en position sur le modèle face sur le dessus et faire glisser le support pour l'enlever.
6. Appuyer avec un chiffon doux humide pour éliminer les bulles d'air.
7. La substance laiteuse qui peut apparaître est destinée à améliorer l'adhésion de l'autocollant et devient incolore au séchage. Essuyer pour enlever tout excédent d'adhésif.
8. Ne pas toucher l'autocollant tant qu'il n'est pas bien sec.
9. Laisser l'autocollant sécher pendant 48 heures avant d'appliquer une couche transparente.

REMARQUE: Les autocollants sont compatibles avec les solutions de fixation ou les solvants.

This optional paint guide is provided if you choose to detail paint your model.

Ce guide de peinture vous sera fourni si vous choisissez de peindre votre modèle en détail.

Aluminum	Aluminum
Flat Black	Noir mat
Flat Lt. Gull Gray FS 36440	Gris clair cendré mat
Flat Sea Blue FS 35042	Bleu de mer mat
Flat White	Blanc mat
Gray	Gris
Gloss Dark Green	Vert foncé lustré
Gloss Dark Red	Rouge foncé lustré
Gloss Sea Blue FS 15042	Bleu mer lustré
Gunmetal	Bronze
Interior Green	Vert intérieur
Leather	Cuir
Military Brown FS 30117	Brun militaire
Olive Drab FS 34102	Olivet
Rubber	Chaotchouc
Silver	Argent
Steel	Acier
Yellow FS 13538	Jaune

If you have any questions or comments, call our hotline at: **(800) 833-3570**
or, please write to:

Revell-Monogram Consumer Service Department, 8601 Waukegan Road, Morton Grove, Illinois 60053
Be sure to include the plan number (85598000200), part number, description, your return address and phone number.

Visit our website: www.revell-monogram.com

1

COCKPIT ASSEMBLY

INSTRUMENT PANEL IS FLAT BLACK WITH GLOSS BLACK INSTRUMENTS AND HAVE WHITE OR PALE YELLOW DETAIL. SWITCHES ARE STEEL.



DECAL 1 IS FOR THE F4U-5N / 5NL VERSION
DECAL 2 IS FOR F4U-5 VERSION

INSTRUMENT PANEL

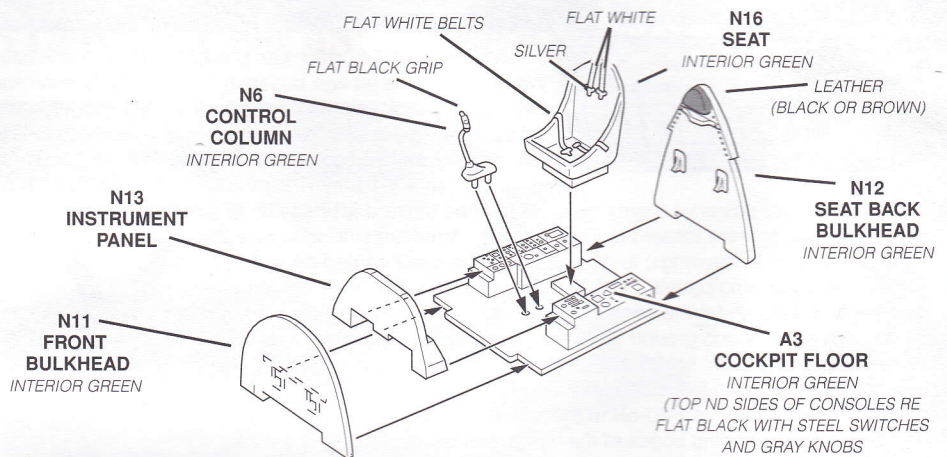

2

FUSELAGE ASSEMBLY

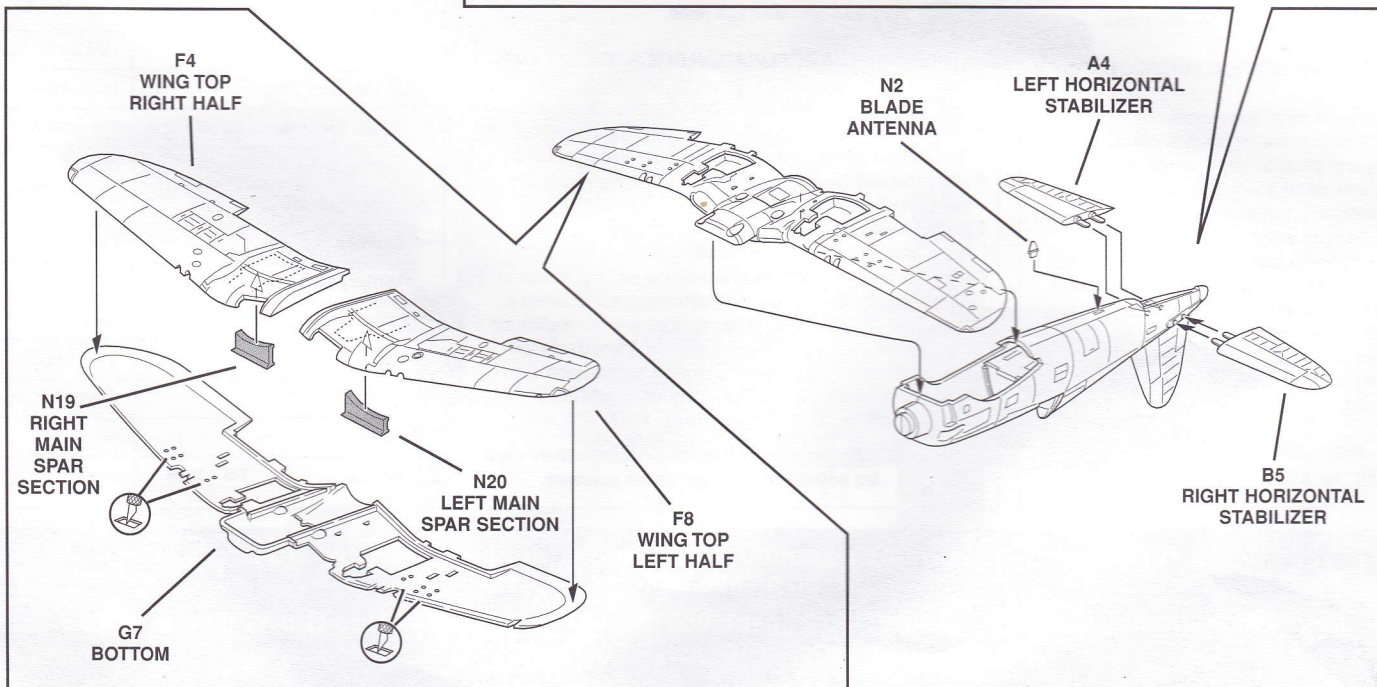
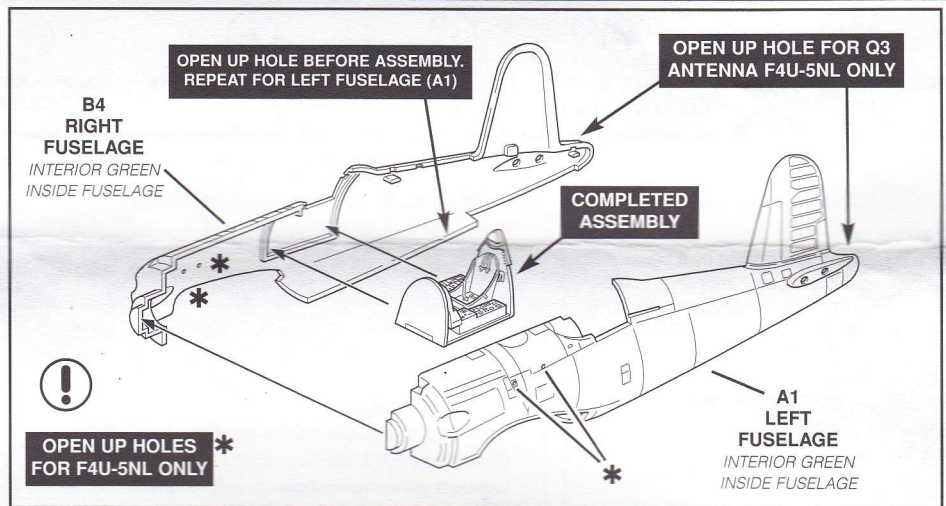

3

ENGINE ASSEMBLY

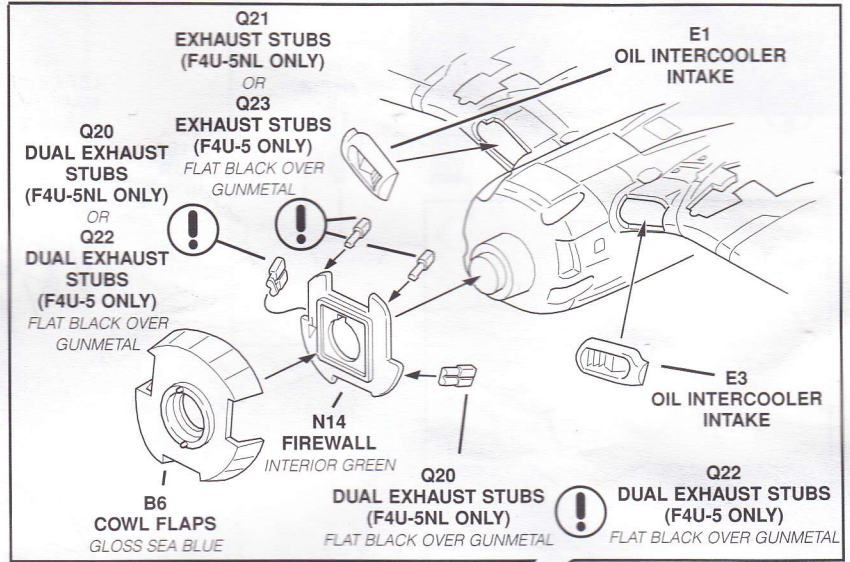
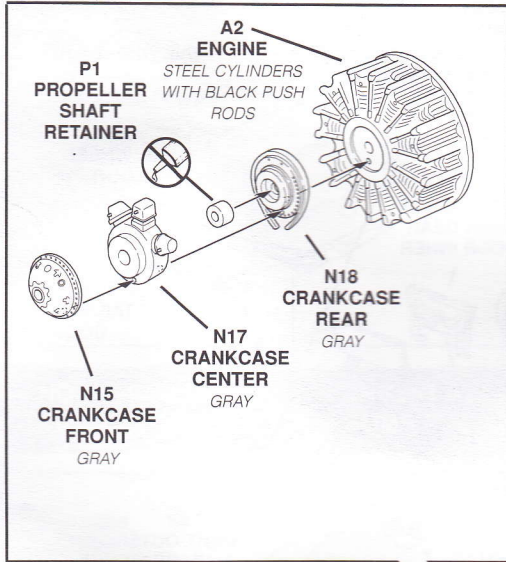

C1 COWLING
INTERIOR GREEN (INSIDE)

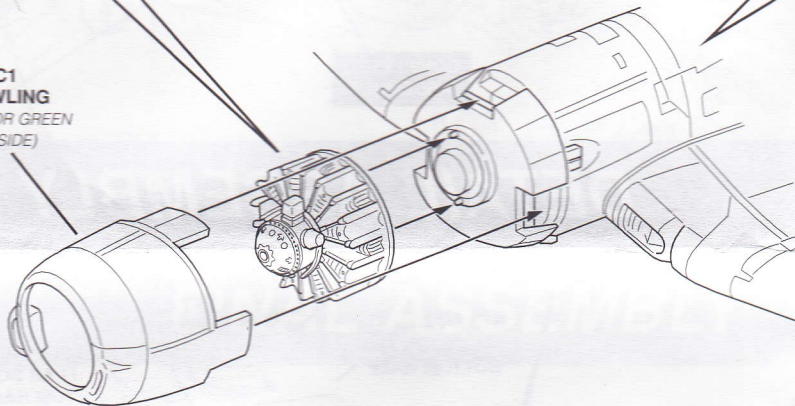

4

MAIN GEAR ASSEMBLY

LEFT MAIN GEAR

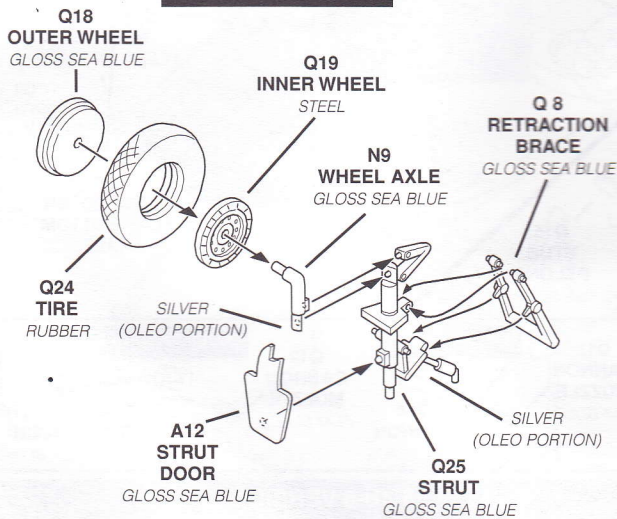

RIGHT MAIN GEAR

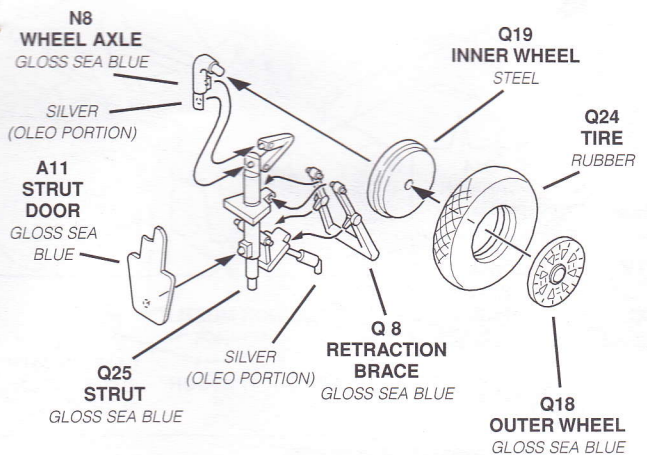

4

MAIN GEAR ASSEMBLY CONTINUED

PAINTING NOTE: BOTH SIDES OF THE GEAR DOORS AND TAIL WHEEL DOORS AS WELL AS THE INTERIOR OF THE GEAR WELLS ARE GLOSS SEA BLUE

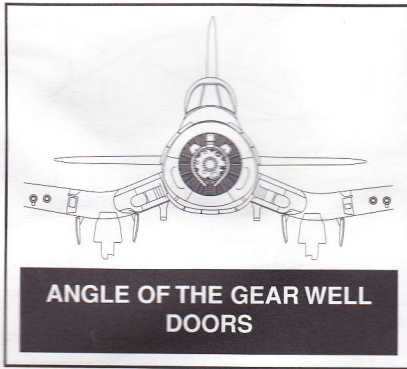

COMPLETED ASSEMBLY

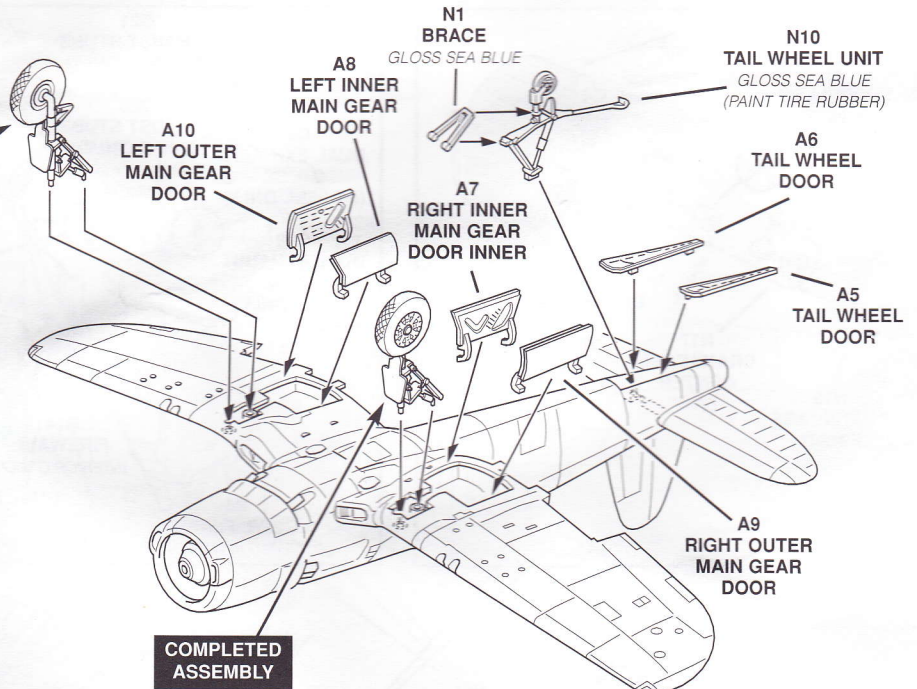

COMPLETED ASSEMBLY

5

DETAIL ASSEMBLY

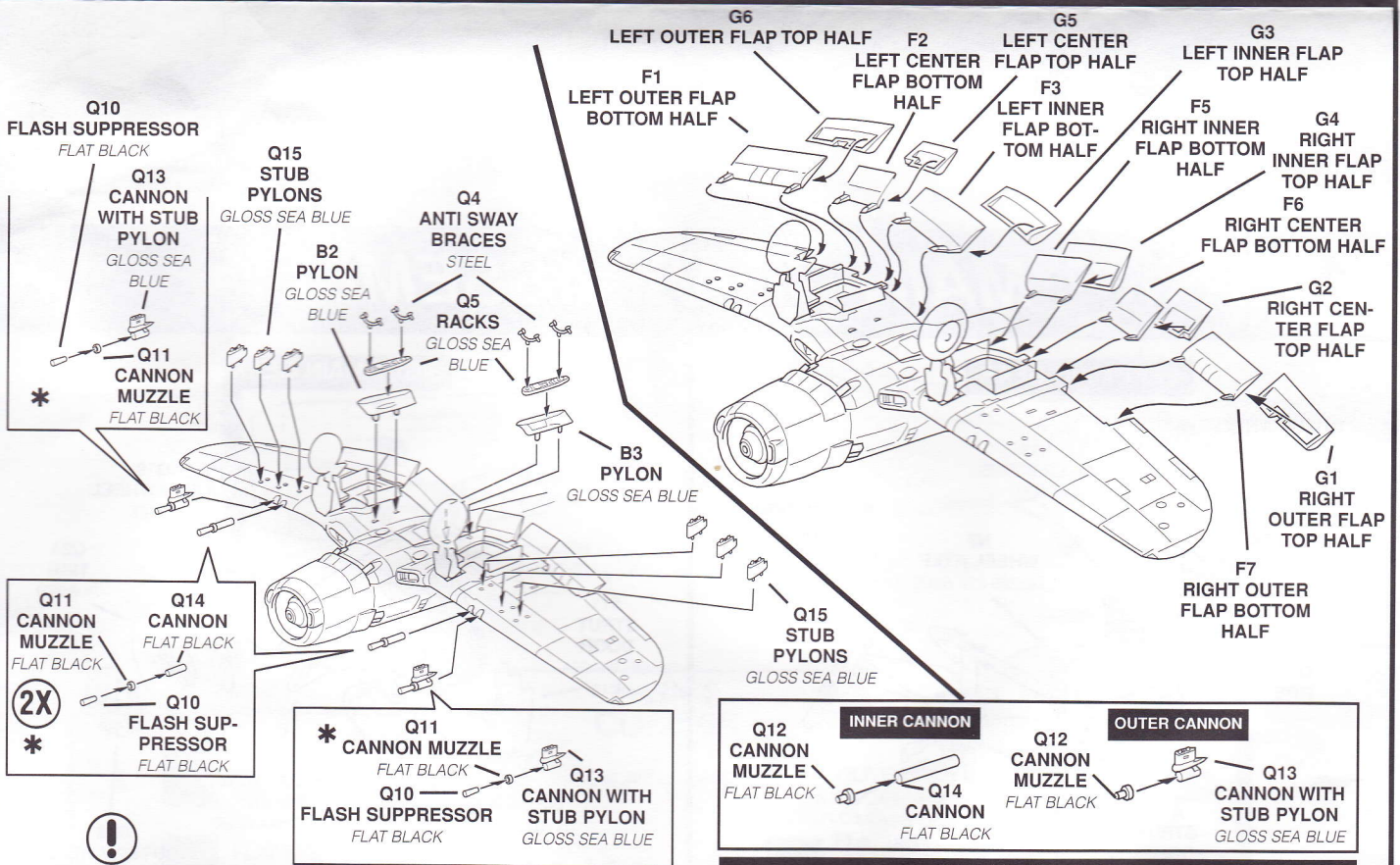

*** F4U-5NL CANNON ONLY**

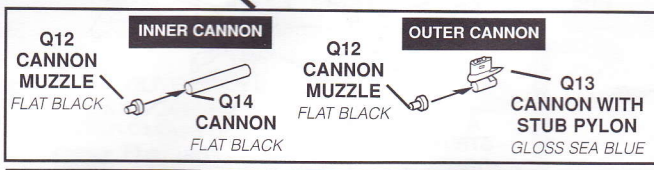

F4U-5 VERSION DOES NOT HAVE FLASH SUPPRESSOR

6

PAYLOAD ASSEMBLY

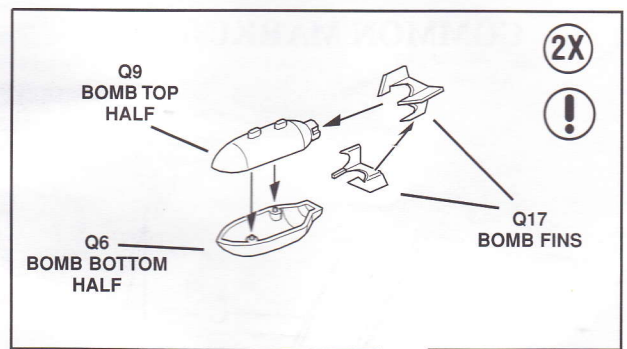
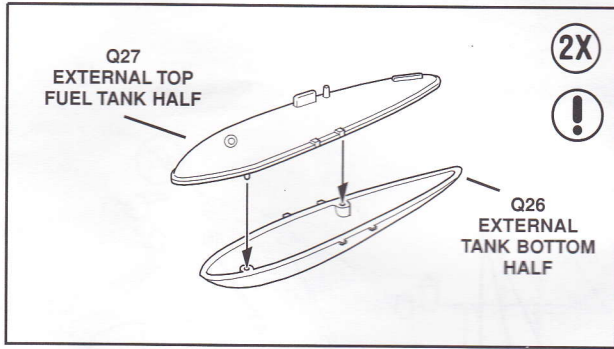

NOTE: TWO FUEL TANKS OR TWO BOMBS OR ONE FUEL TANK AND ONE BOMB MAY BE USED

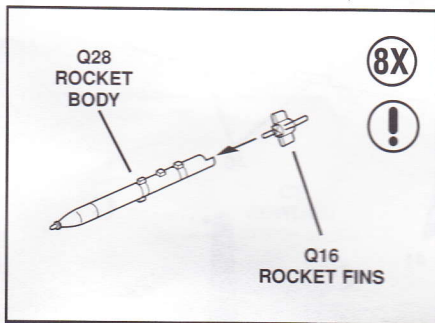

NOTE: SEE DECAL PLACEMENT FOR PAINT DETAILS ON PAYLOAD ASSEMBLY

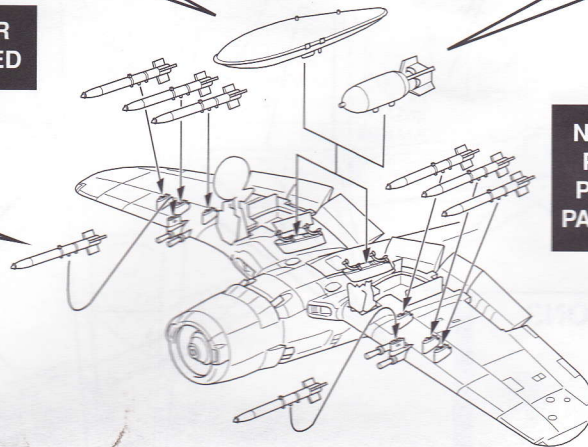

7

FINAL ASSEMBLY

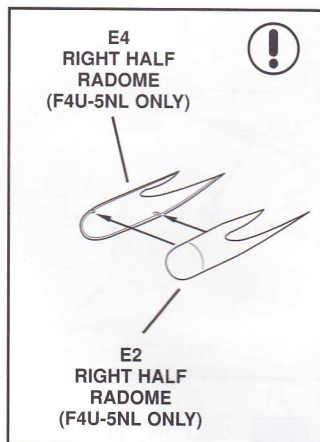



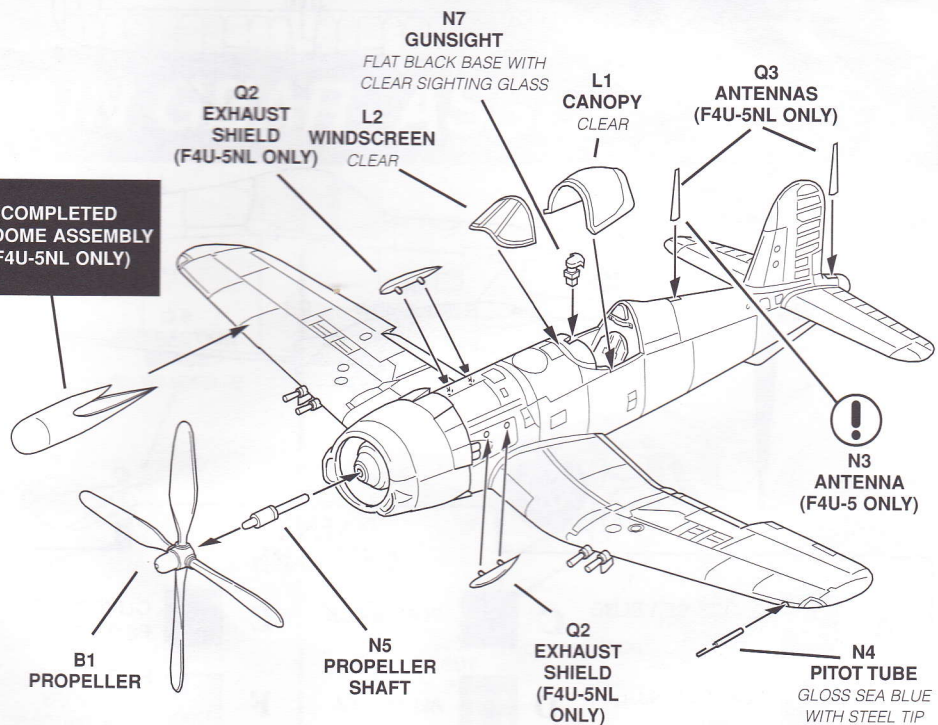



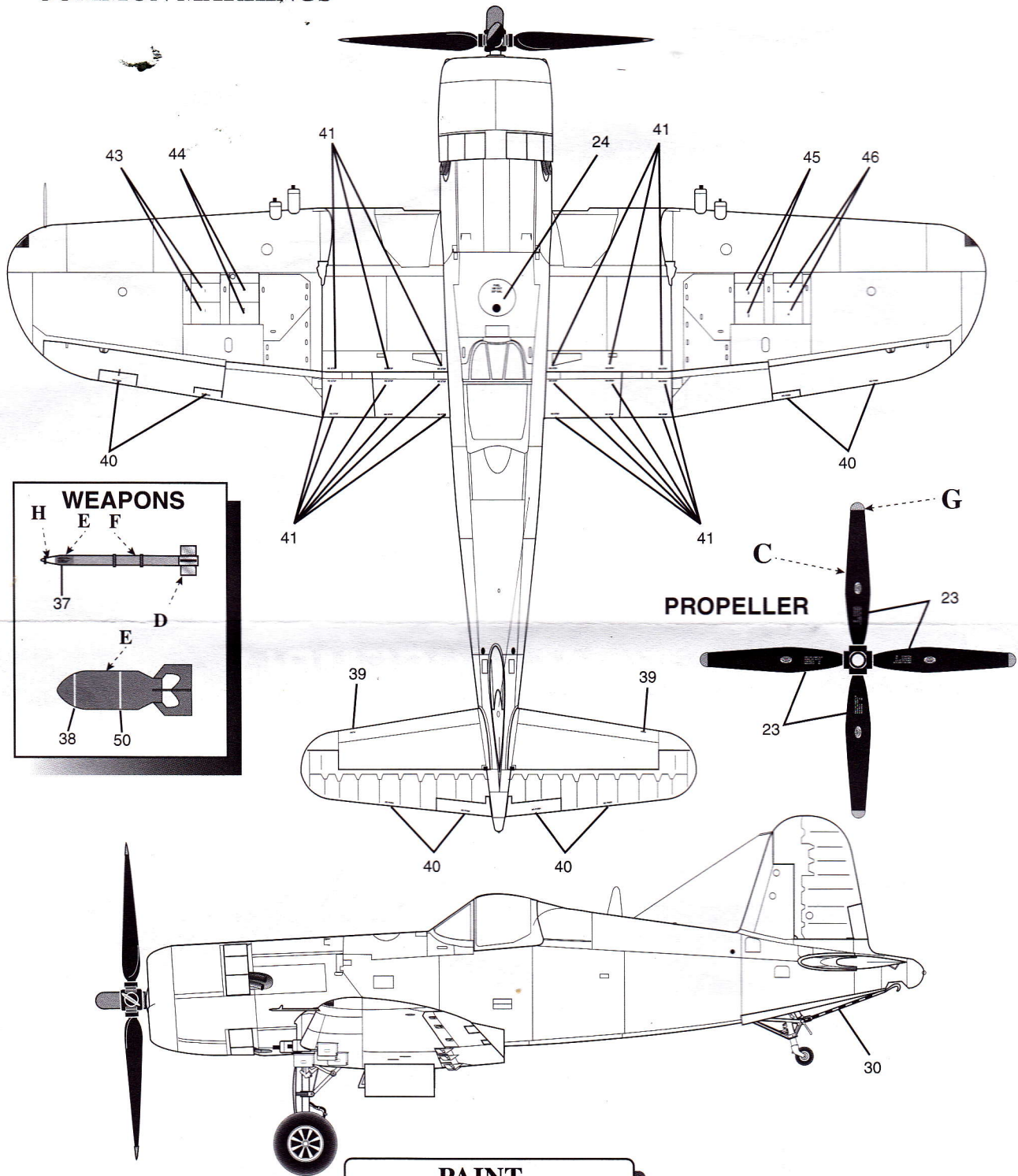

**COMPLETED
RADOME ASSEMBLY
(F4U-5NL ONLY)**



COMMON MARKINGS



PAINT COLORS

A	 GLOSS SEA BLUE FS 15042	C	 FLAT BLACK	E	 OLIVE DRAB FS 34102	G	 YELLOW FS 13538
B	 FLAT SEA BLUE FS 35042	D	 ALUMINUM	F	 FLAT LIGHT GULL GRAY FS 36440	H	 FLAT WHITE

F4U-5NL, VC-4

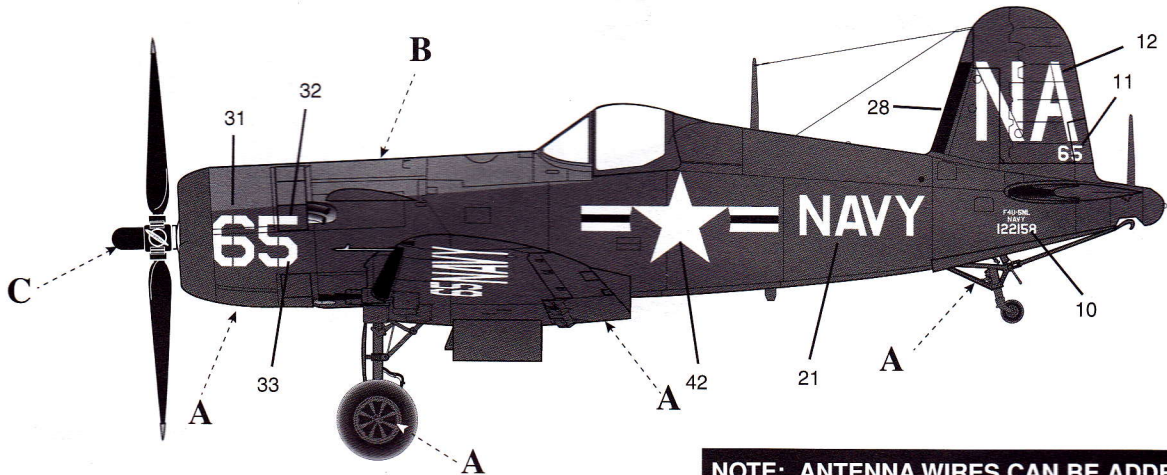

NOTE: ANTENNA WIRES CAN BE ADDED USING STRETCHED SPRUE OR FINE NYLON THREAD

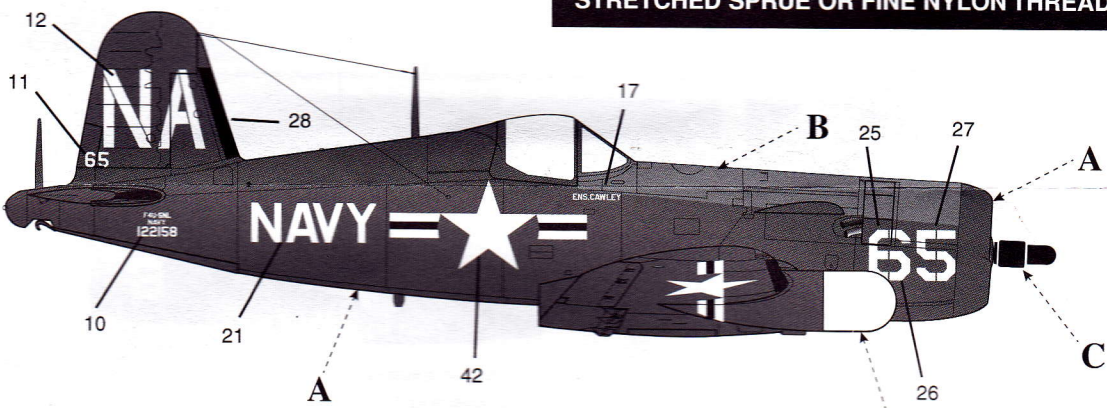

LEFT LIGHT:
DARK RED

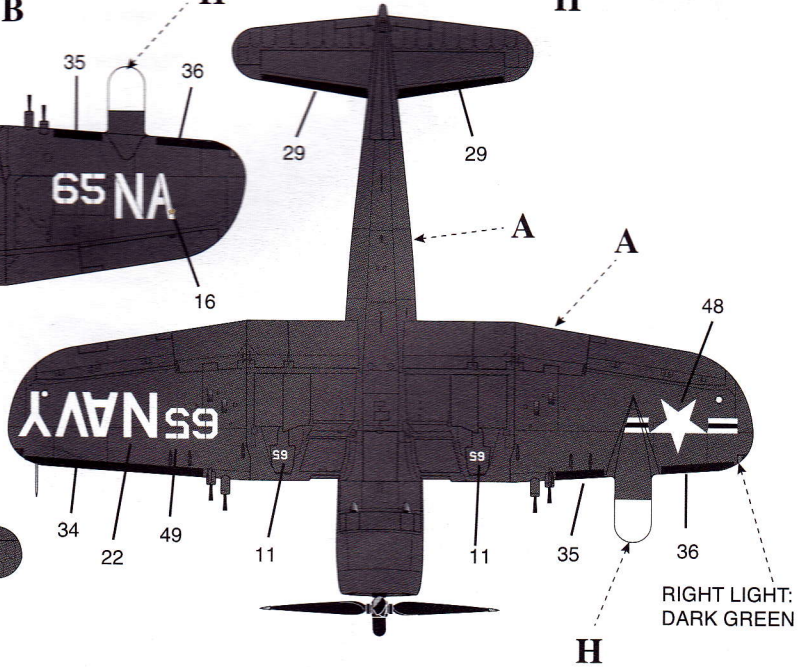
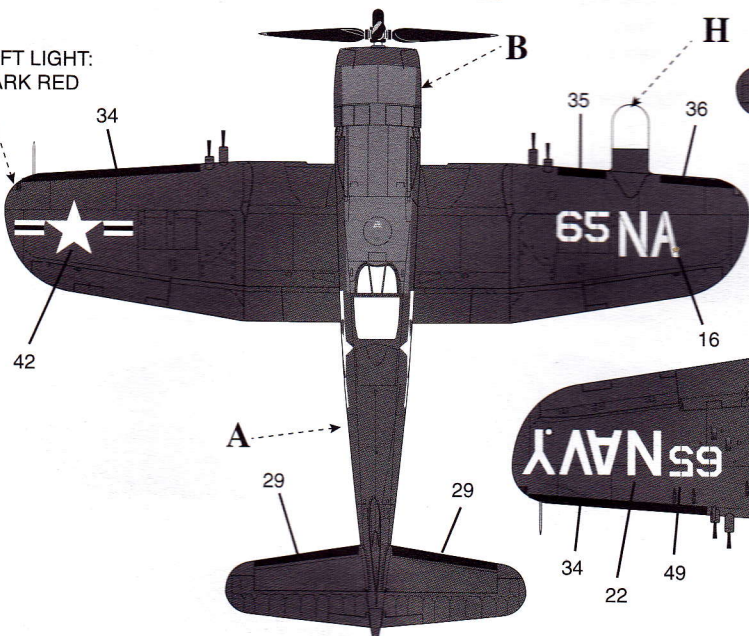

RIGHT LIGHT:
DARK GREEN

F4U-5, NAS GLENVIEW, ILLINOIS, RESERVE SQUADRON

NOTE: ANTENNA WIRES CAN BE ADDED USING STRETCHED SPRUE OR FINE NYLON THREAD

