

1

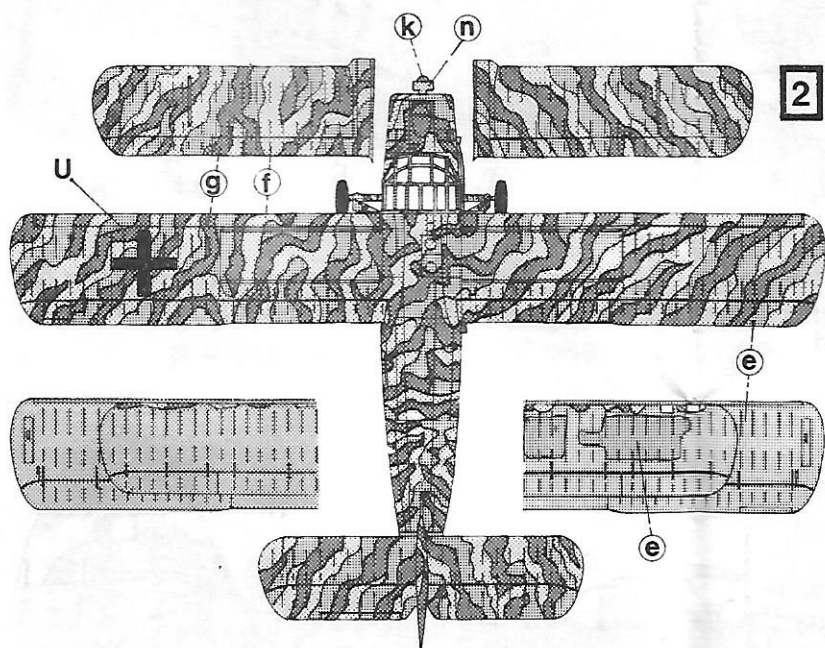

2

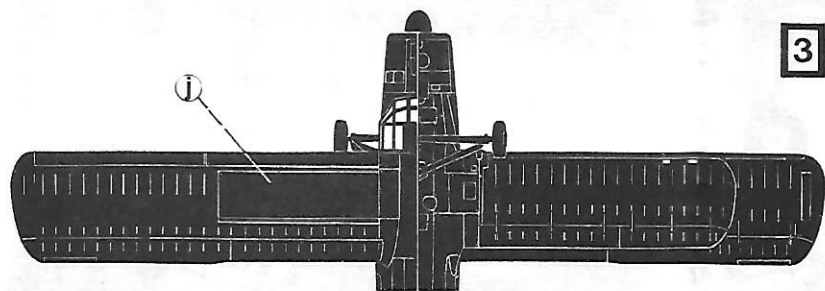

3

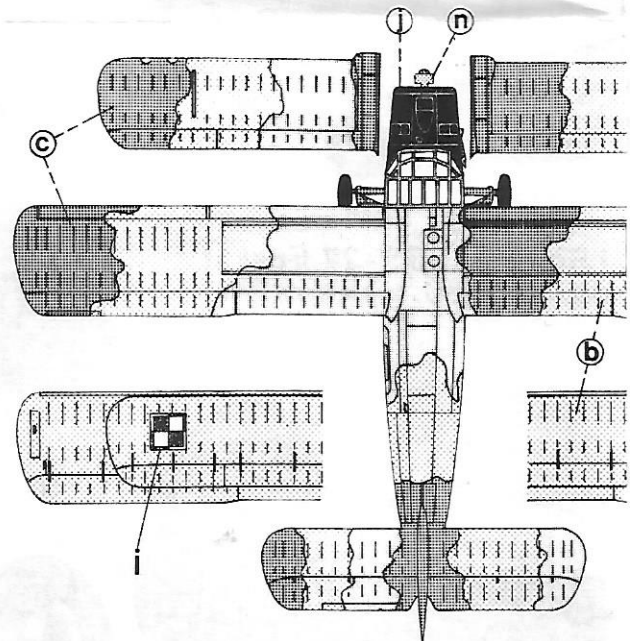
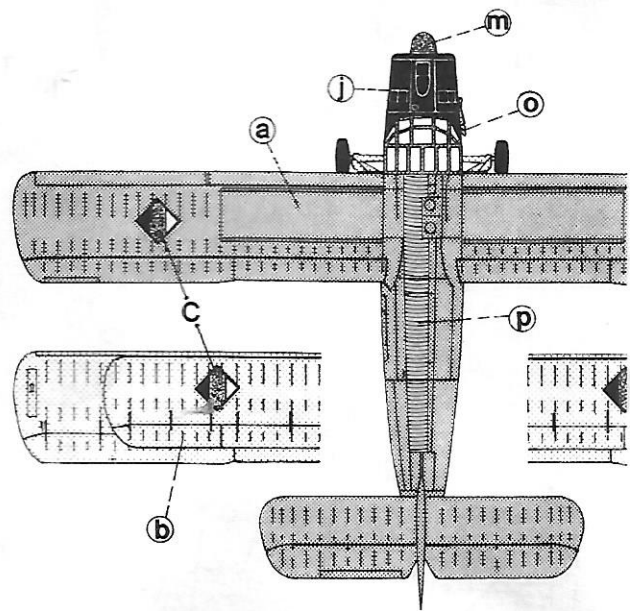
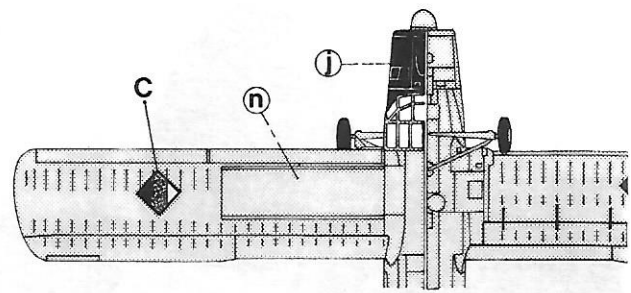

Recommended references:

- * An-2 - Pierwsze 50 lat. Skrzydła w miniaturze N°14
- * "Annas" in Deutschland - Ein Kapitel An-2 Geschichte. Fliegerrevue Edition N°7
- * Air Forces of Former Yugoslavia 1991-97 - Pt.1, Croatia & Bosnia. Insignia Special N°2
- * Aeroplan N°1
- * Replic N°
- * World Air Power Journal Vol.13

Model kits produced by
Bilek and Italeri

AN-2 COLT

72-046

Acknowledgements:

We would like to express our
Jan Hoffmann
Klaus Meissner
and to the Museum of Polish
for the assistance provided
ration of this decal sheet.

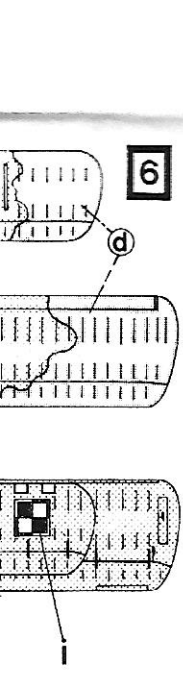
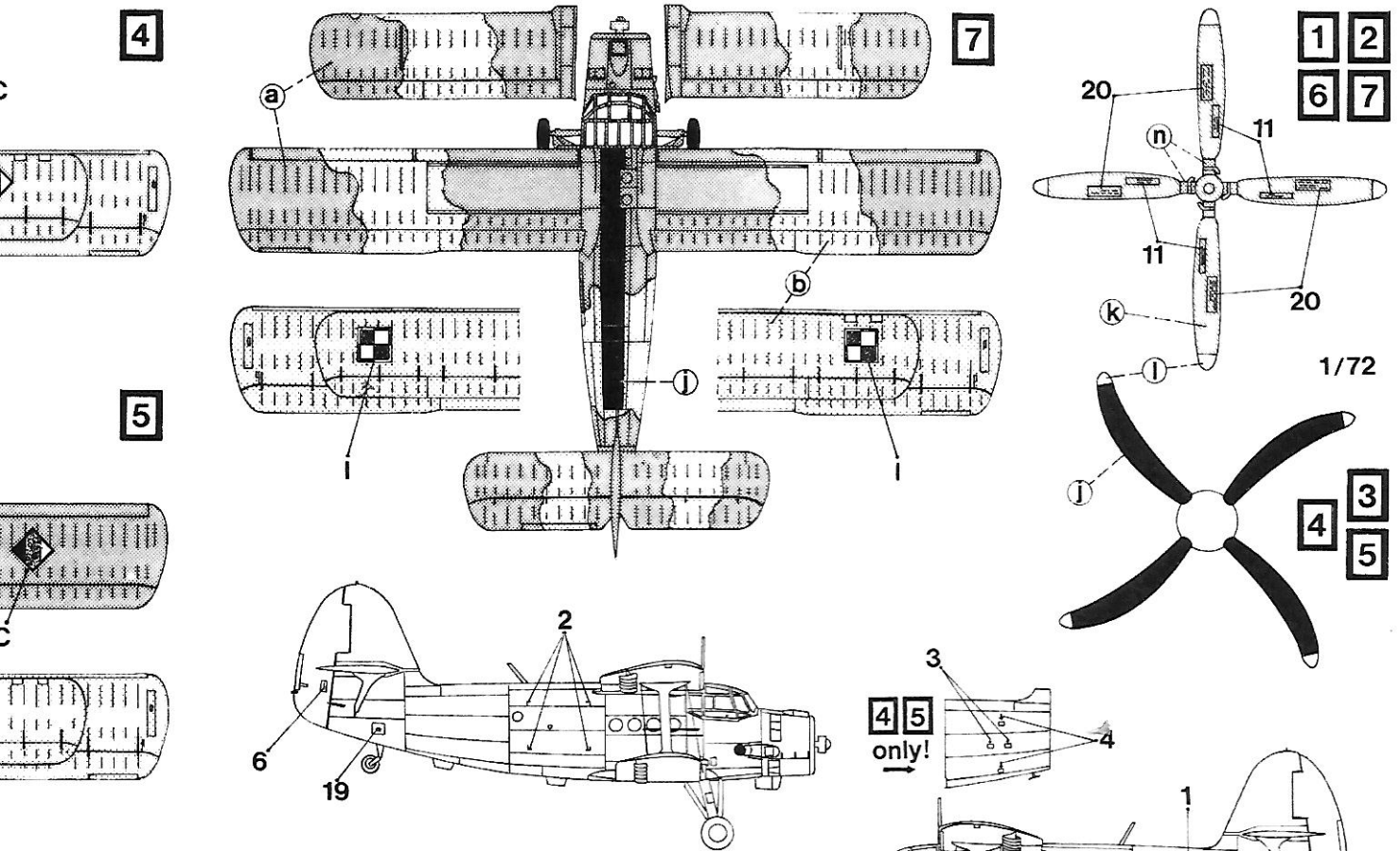

Stencil data for **4 5 6 7**

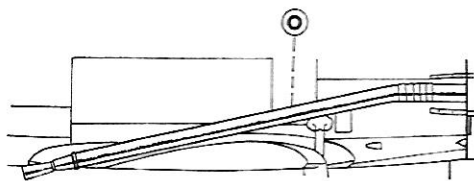
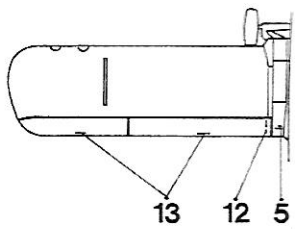
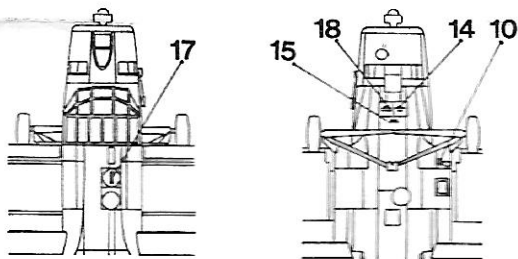

Exhaust pipe
Versions **1 2**
1/72

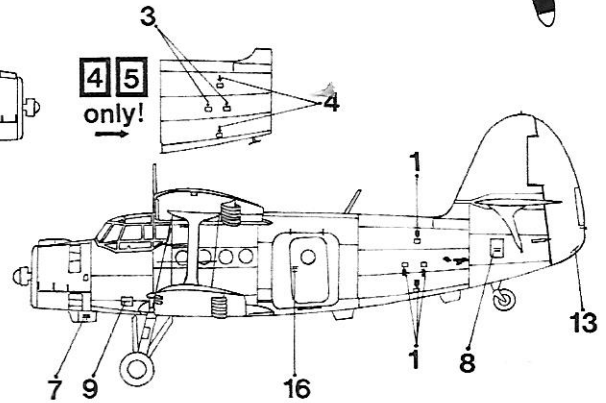

	Humbrol	Model Master
a	Dark Green FS 24102	117 1713
b	Light Blue FS 35526	89 10% 1562 10% 147 +90% 1732 +90%
c	Medium Green FS 34097	105 1712
d	Sand Yellow FS 33481	81 1584
e	Blue Grey FS 34233	115 2123
f	Sand FS 33434	7 2088
g	Olive Drab FS 34086	108 2084
h	Forest Green FS 34127	150 1714
i	Brown FS 30118	110 2054
j	Black FS 37038	33 1583
k	Dark Blue FS 35109	96 10% 2031 109 +90%
l	Yellow FS 23655	69 1569
m	Red FS 21140	19 1503
n	Polished Aluminium	Metalcote 1401
o	Exhaust	56 50% 1781 50% 12 +50% 1551 +50%
p	Khaki Drill FS 30277	72 -

...ratitude to
...iation / Krakow
...ring the prepa-

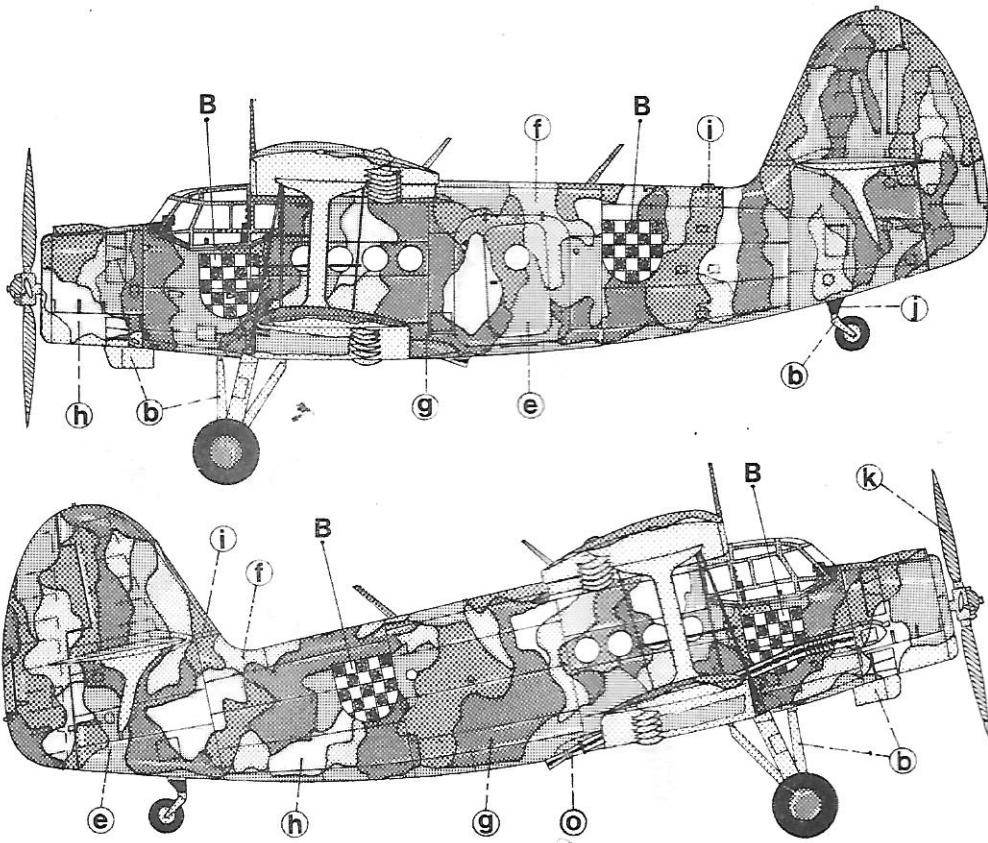

1 An-2 R Colt, Independent Air Unit SZV "Osijek", Croatian Air Force, used as night bomber during the siege of Vukovar in November 1991.

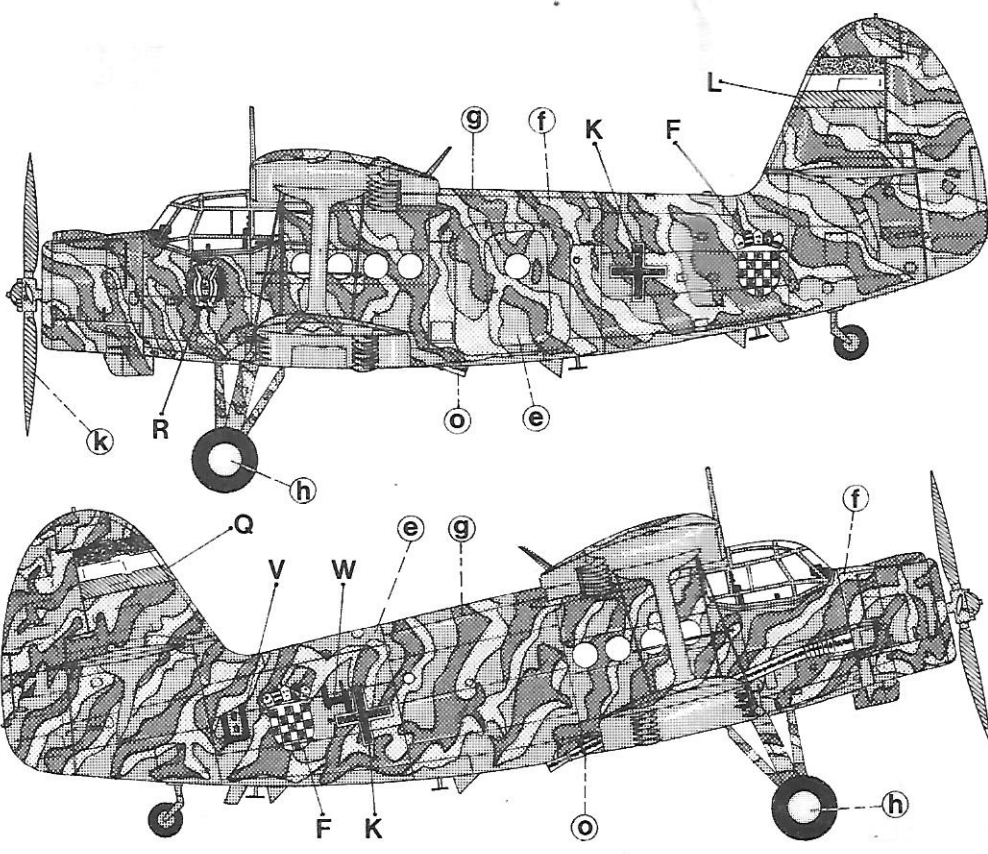

2 An-2 R Colt, medevac aircraft, SZV "Osijek", Croatian Air Force; Osijek AB, Spring 1992.

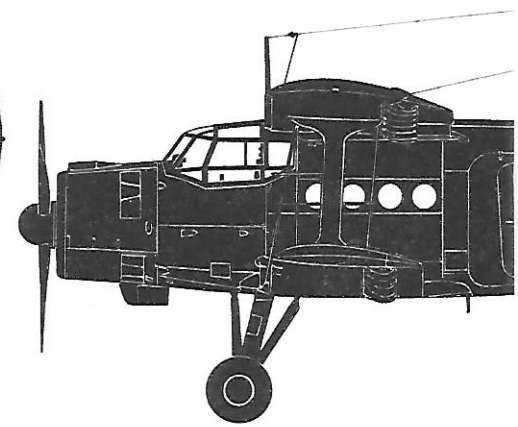

3 An-2TD Colt, North Korean infiltration flights into S

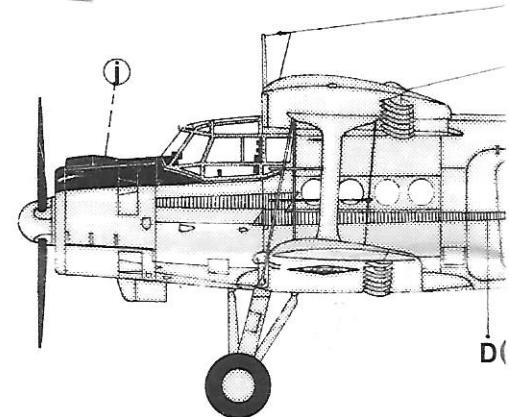

4 An-2P Colt, Air Transport, German Air Force; Dresden

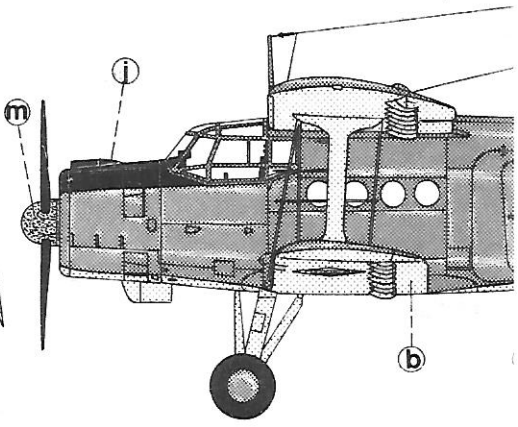

5 An-2T Colt, Air Communication, East German Air Force; Dresden

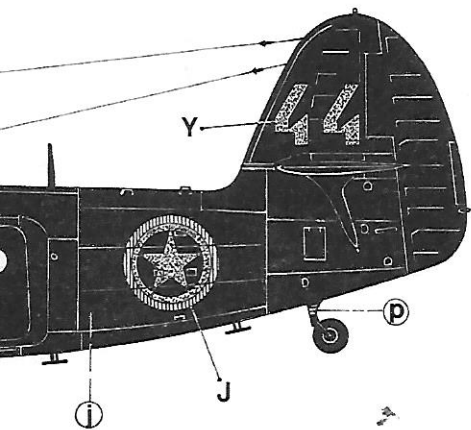

an Air Force, used for
outh Korea; 1984.

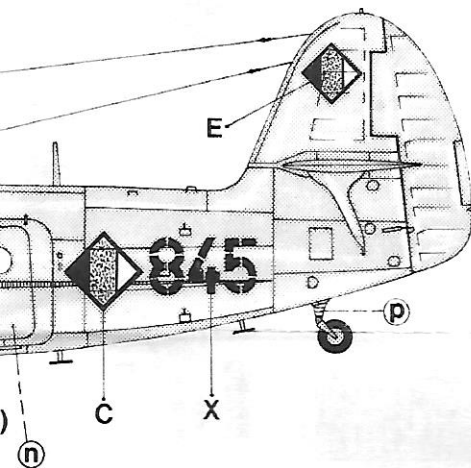

t Squadron TS-27, East
en AB, 1958.

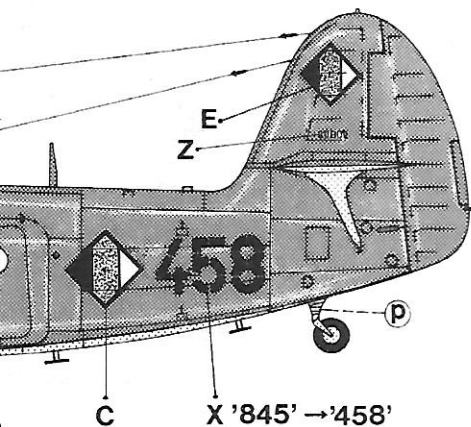

ications Squadron VS-25,
rausberg AB, 1958.

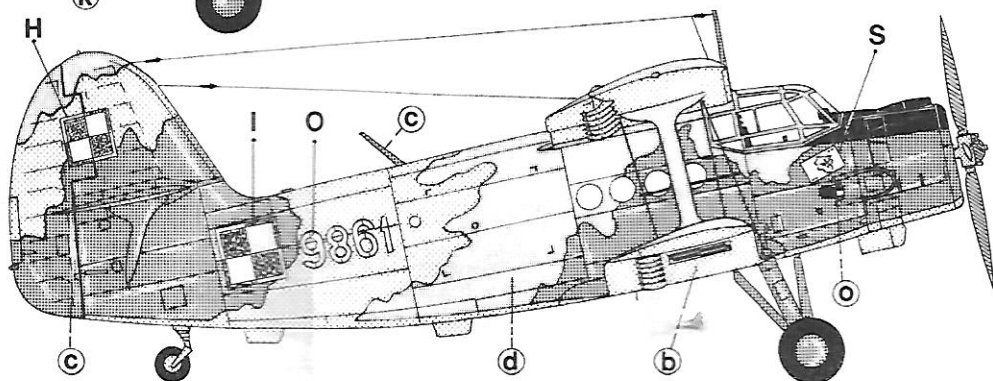
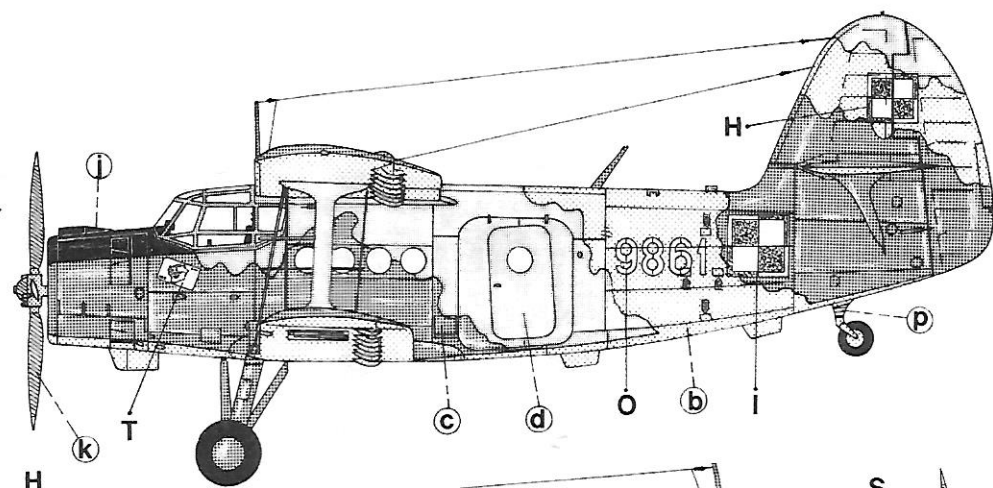

6 An-2T Colt, liaison/utility aircraft from 11th Fighter Air
Regiment, Polish Air Force; Wroclaw-Starachowice AB,
1991.

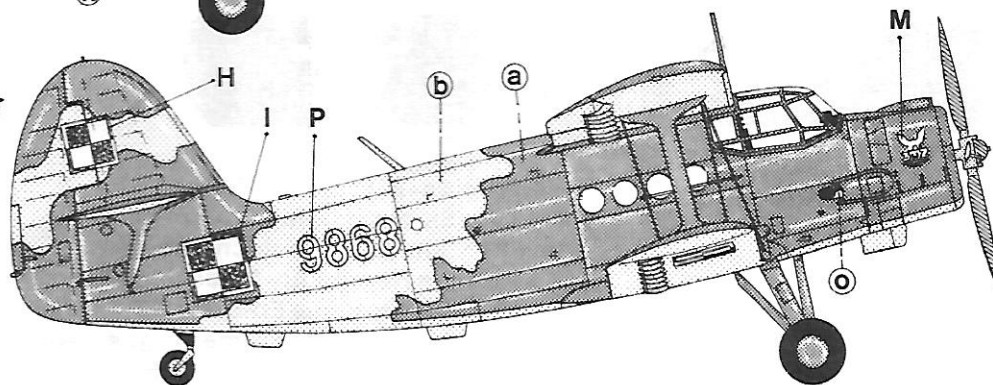
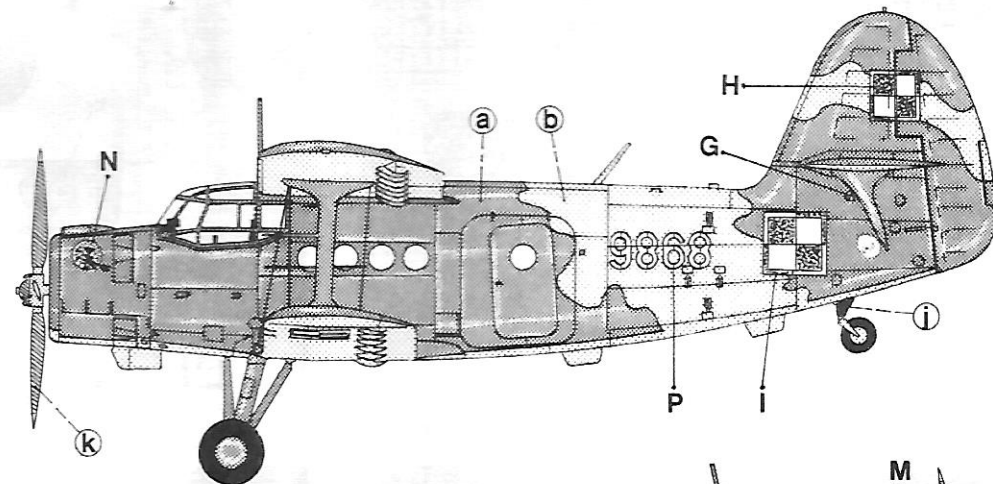

7 An-2T Colt, liaison/utility aircraft from 2nd Squadron,
32nd Tactical Reconnaissance Regiment, Polish Air
Force; Sochaczew-Bielice AB, 1992.