

McDONNELL DOUGLAS F-4E PHANTOM II

1085

1/72 SCALE

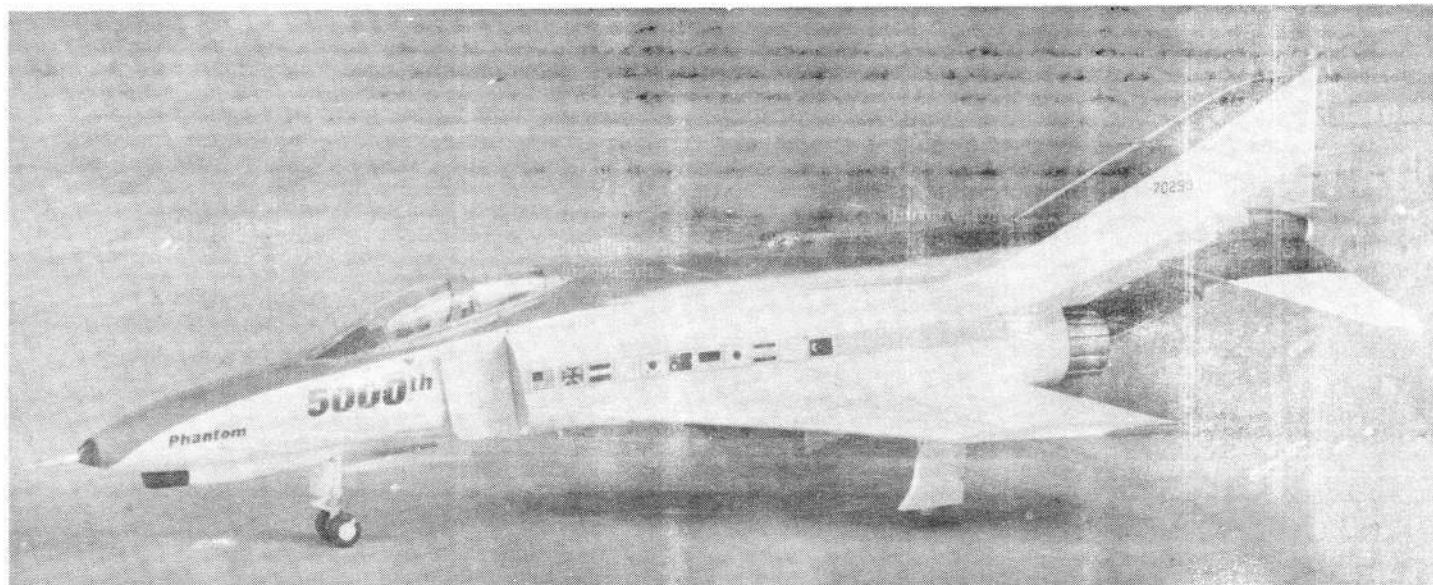

HISTORY

The McDonnell Douglas F-4 Phantom II is possibly the most successful fighter aircraft yet built. Starting its career as a proposed single-seat fighter it grew into a twin-engined, two seat, double sonic fighter capable of nearly all military combat roles. Over 4,500 Phantom II's have been built in more than 12 different subtypes and are being flown by several air arms throughout the world. Among these the F-4E is the only version to have built-in cannon armament. The F-4E was first flown on June 30, 1967 and differed from earlier types in the nose design. This was a modification from the RF-4 photo-reconnaissance model. Surveillance equipment was deleted and an M-61A1 20 mm Vulcan cannon was faired into the new nose. More powerful engines and a larger fuel capacity also distinguish the F-4E from earlier Phantoms. The role of the Phantom in combat has become a classic history. In the far east and the middle east it has shown its superiority over Russian-built Mig fighters. But in addition to its military abilities the Phantom has become the showpiece of precision flying teams. Among the most colorful teams is the U. S. Air Force Thunderbirds. Flying F-4E's, the Thunderbirds have thrilled spectators throughout the world with their tight-formation manoeuvres. Flying only three feet apart the Thunderbird Phantoms perform manoeuvres no other plane is capable of. Their remarkable performance is due to the great margin of extra power available from their afterburning General Electric J79 jet engines. With 17,900 lbs of thrust from each engine the F-4E can climb 28,000 feet in one minute!

In war or peace, the Phantom II has proven itself a champion in all respects.

CHARACTERISTICS

Wingspan: 38 feet 5 inches

Length: 62 feet 11 inches

Powerplant: Two General Electric J79GE-17, 17,900 lbs thrust with afterburner

Maximum Speed: 1,584 mph (Mach 2.4)

Service Ceiling: 70,000 feet

Armament: M-61A1 20mm Vulcan rotary cannon, four AIM-7 Sparrow missiles, a variety of bombs, Sidewinder missiles and laser-guided "Smart Bombs" which are directed precisely to their targets

MINICRAFT MODELS, INC.

1510 W. 228th STREET

TORRANCE, CALIFORNIA 90501

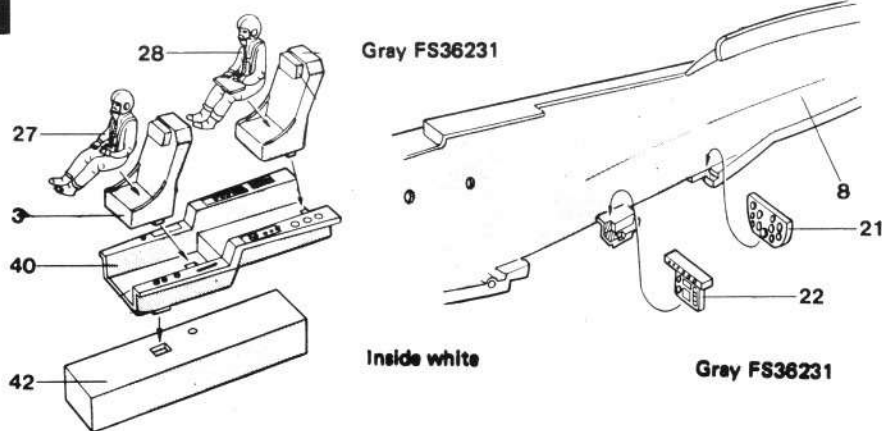

1

Cement pilot (27) and Radar Officer (28) to seats (3) and cement to cockpit floor (40). Cement (40) to nose wheel well (42). Invert right fuselage side (8) and cement front instrument panel (21) and rear panel (22) in place.

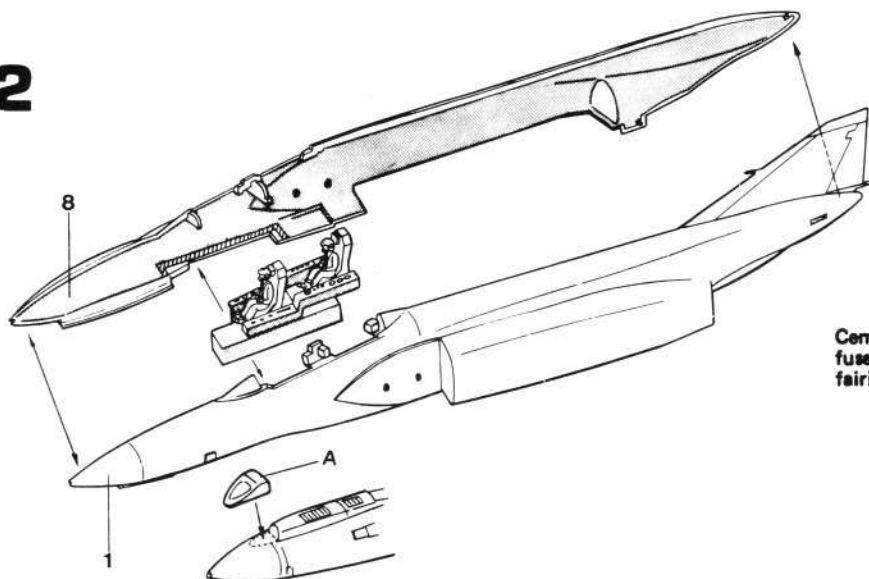
**2**

Cement cockpit assembly to right fuselage side and fuselage halves (1 and 8) together. Cement cannon fairing (A) to underside of nose.

3

Cement small scoop (48) to nose. Cement intake ramps (36 and 37) to fuselage sides and cement air intakes (34 and 35) in place over ramps as shown. Cement lower wing center (14) to fuselage. Cement upper wing sections (15 and 16) to lower wing section and fuselage. Cement stabilizers (17 and 18) in place on fuselage. Make center fuel tank A by cementing together (38 and 39). For wing tanks B cement together (13 and 10) and pylon (5). For wing tanks C use parts (11, 12, and 6).

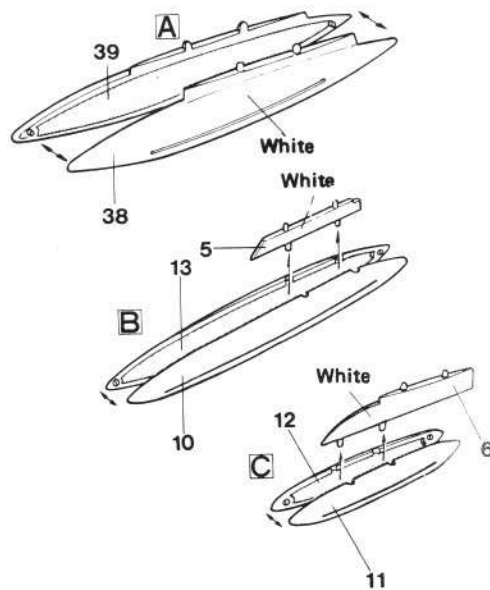
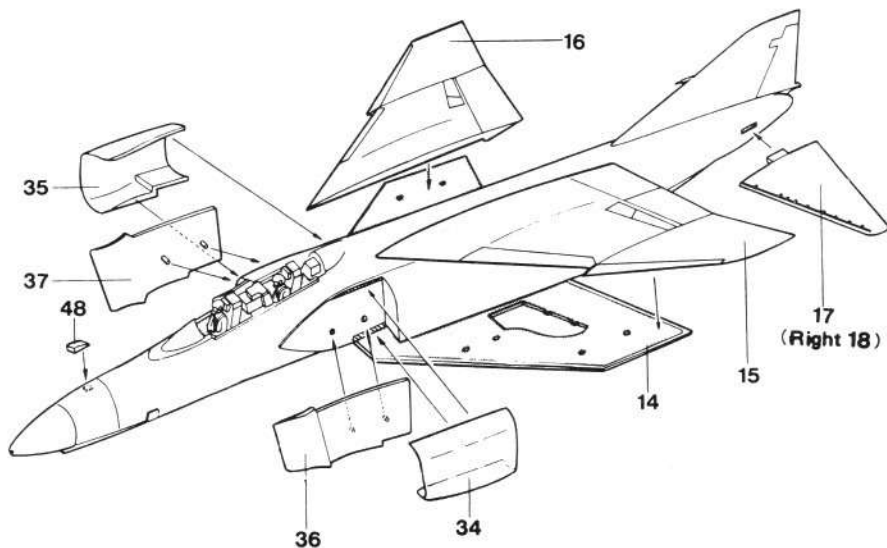

4

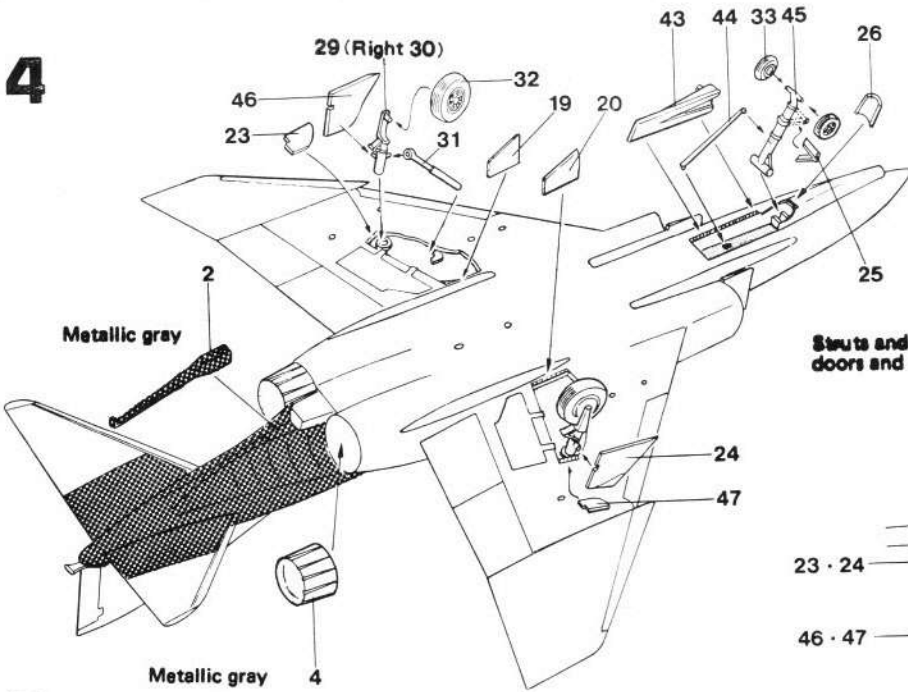

Make right main landing gear by cementing tire (32) to strut (30). Cement retracting arm (31) to strut and cement gear to wing. Cement cover door (23 and 48) to strut. Refer to detail drawing for proper placement. Repeat with parts (29, 31, 32, 24 and 47) for left gear. Cement inner doors (19 and 20) in place as shown. Cement nose shock link (25) to nose strut. Refer to detail for proper angle of link. Cement tires (33) and retracting arm (44) to strut and cement unit into nose well. Cement nose gear doors (26 and 43) in place as shown in detail drawing. Cement tail pipes (4) and arresting hook (2) to fuselage.

Struts and inside all gear doors and wheel wells: White

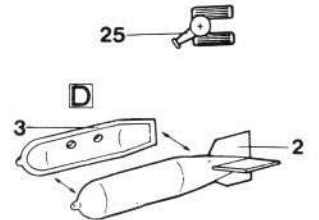
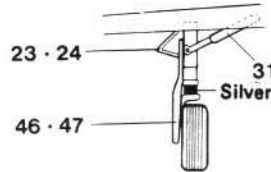
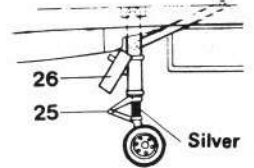

5

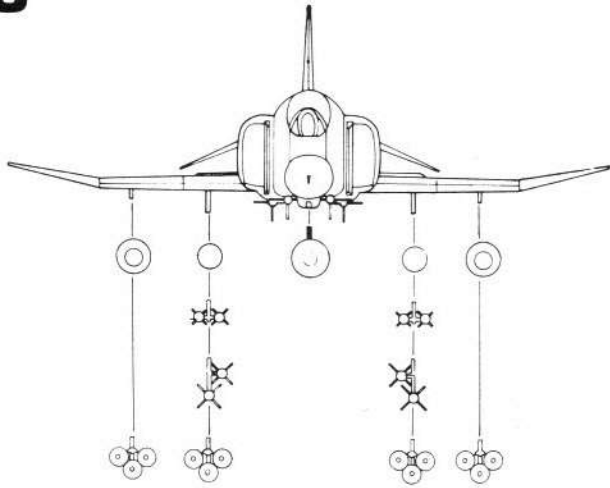

Make bombs D by cementing (2 and 3) together. For bombs E cement (1 and 4) together. Now cement two D's and one E to rack (13) and pylon (7) for assembly F. Make two. Cement clear canopy to cockpit. Cement pitot tube (9) to nose.

Your F-4E model is provided with a wide variety of stores. Refer to front view drawing for possible combinations. Phantoms usually carry four Sparrow missiles under the fuselage in addition to the underwing stores. Letters

(A) and (B) show proper locations for pylons.

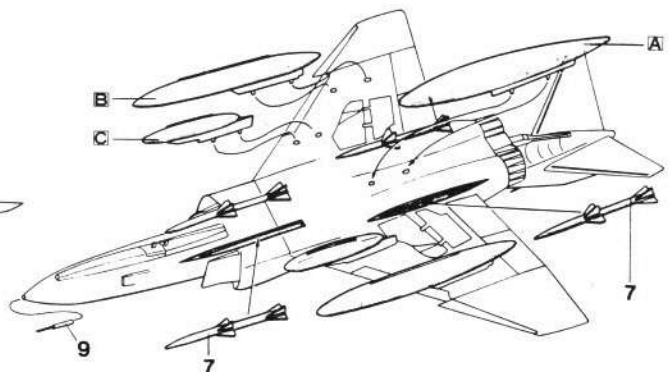
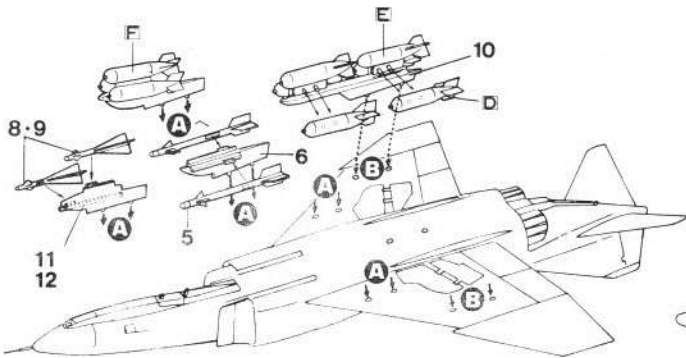
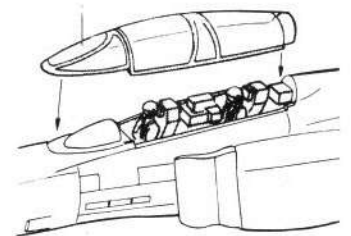
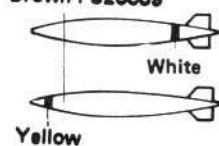
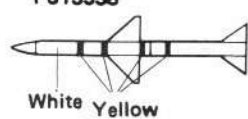
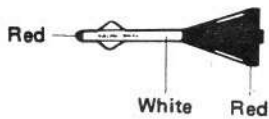
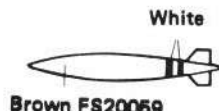
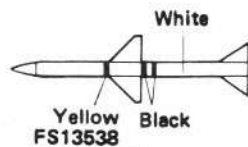
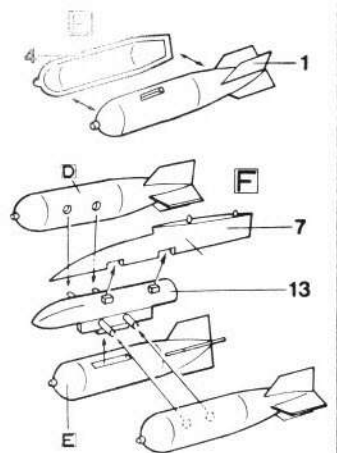

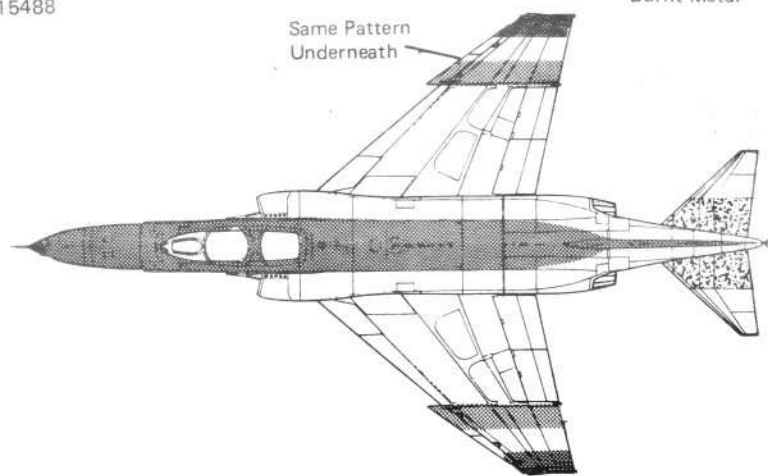
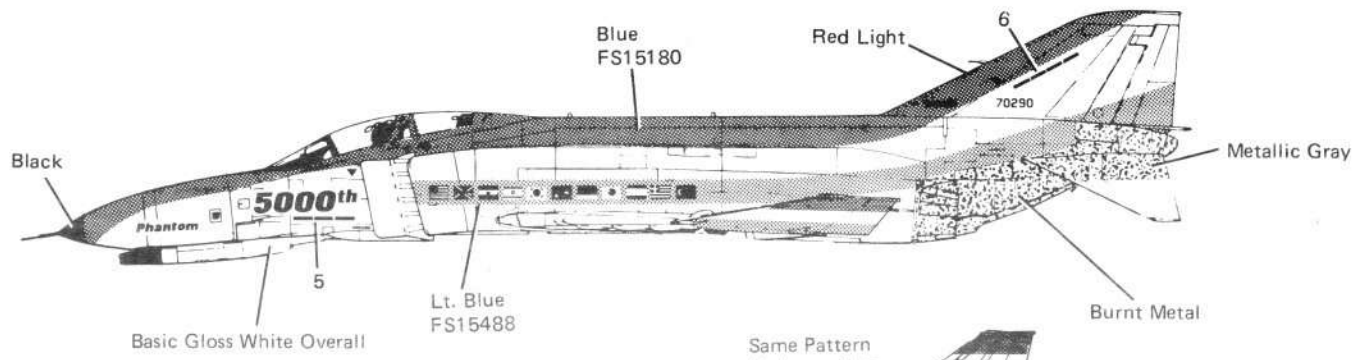

NUMBERS REFER TO DECALS

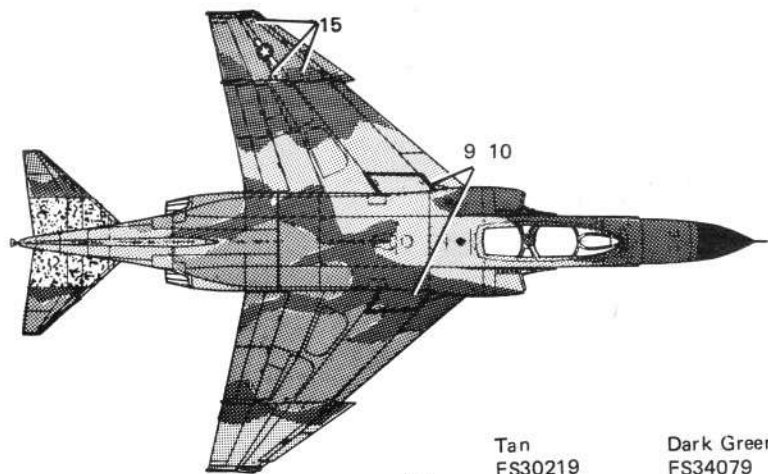

Silver leading edges on all planes

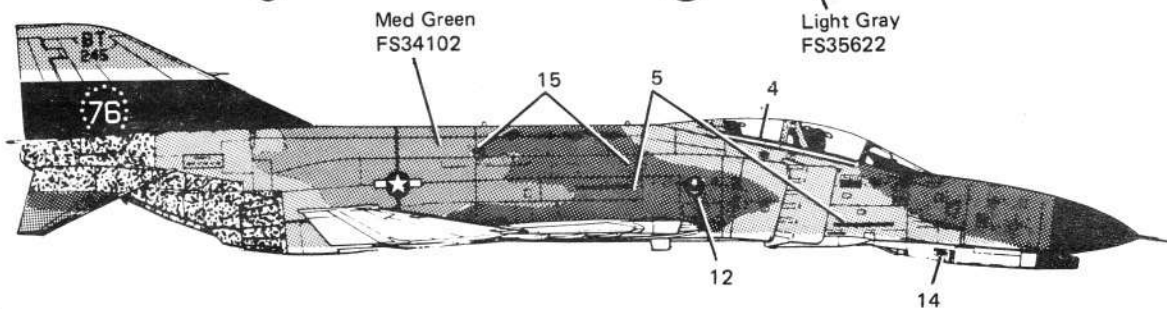
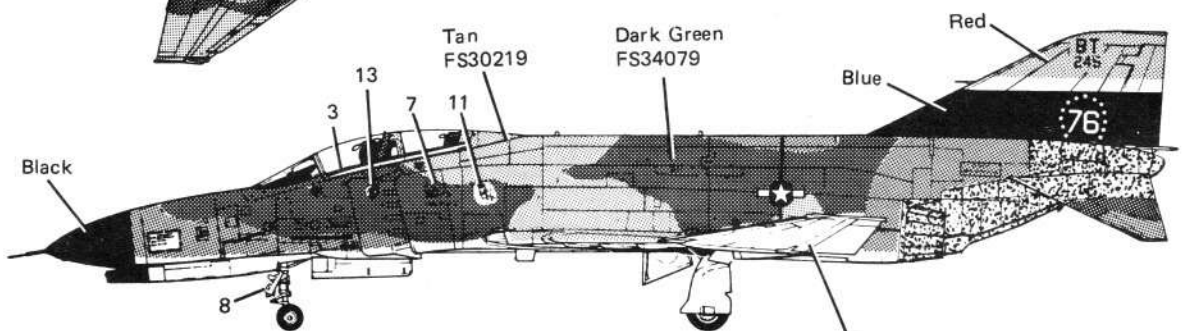



CASHER
ARRESTOR MARK



CASHER
ARRESTOR MARK



F-4E

PHANTOM II



11

12

14

13

8

6

5

3

76

1

BT
245

CAT # 1085

BT
245

2

76

5

4

15

15

70290
70290
Phantom
Phantom
5000th
5000th

CASHER
ARRESTOR MARK

CASHER
ARRESTOR MARK

