



**WAR
EAGLE**[®]
INCORPORATED

MiG-17F/PF (Fresco-C/D) Day/Night-Fighter Camouflage & Markings

- 1) Read the instructions on the back of the decal sheet before proceeding.
- 2) The modeler should check his or her references for the specific aircraft being modeled to aid in exact placement of camouflage and markings.
- 3) The Egyptian and Ugandan markings can also be used for MiG-17PF (Fresco-D) 'night-fighter' versions. Camouflage and markings locations follow the (Fresco-C) 'day-fighter' schemes.
- 4) A MiG-17PF (Fresco-D) 'night-fighter' vacuum-form kit is available from War Eagle® Inc. The kit contains vacuum-form fuselage, wings, etc., Clear-Vax canopy, cast resin radar nose and cockpit tub,

metal detail parts and etched brass wing fences.
Tel.: 313/727-1660. Fax: 313/727-1824.

A	FS?????	natural metal
B	FS33613	tan
C	FS30118	brown
D	FS?????	Soviet pale grey blue
E	FS34102	green
F	FS30117	red brown
G	FS34077	dark green
H	FS34258	light green
I	FS31136	red

© 1989 War Eagle® Inc., P.O. Box 327, Richmond, MI 48062 USA.
All rights reserved.

Egyptian: MiG-17F (Fresco C)

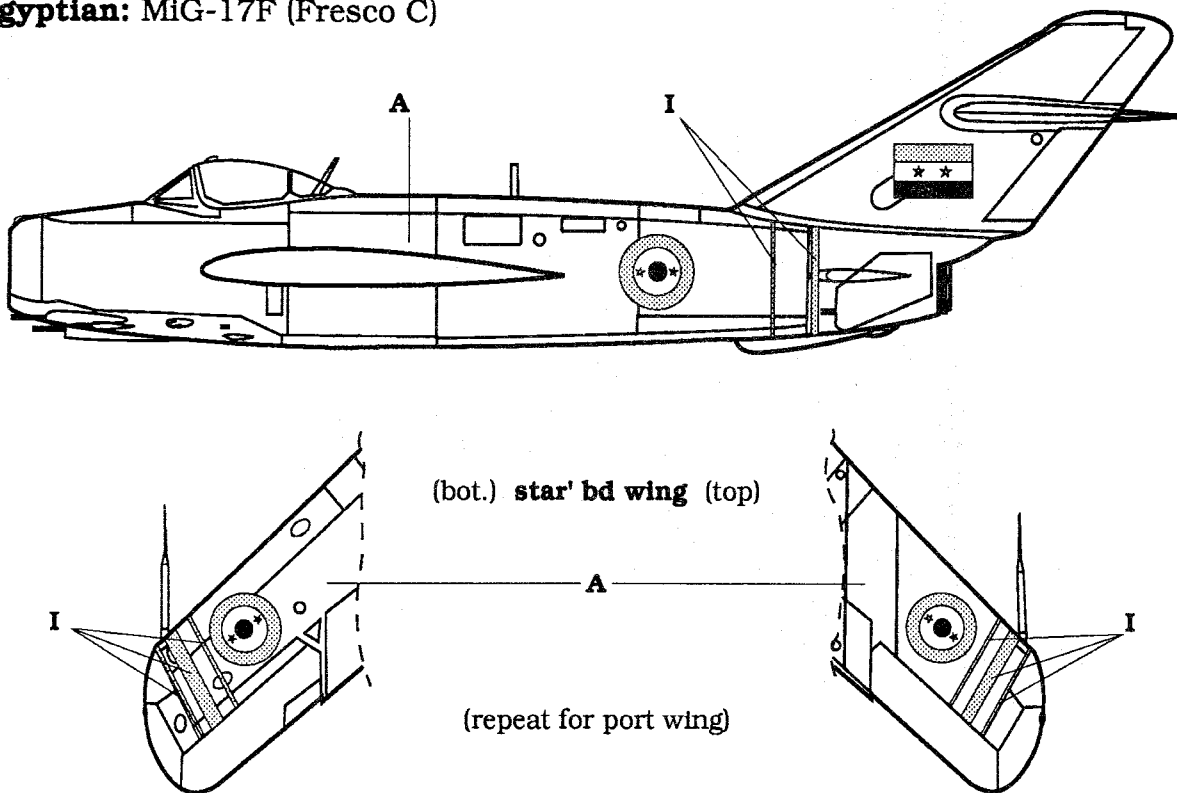

Egyptian: MiG-17F/PF (Fresco C/D)

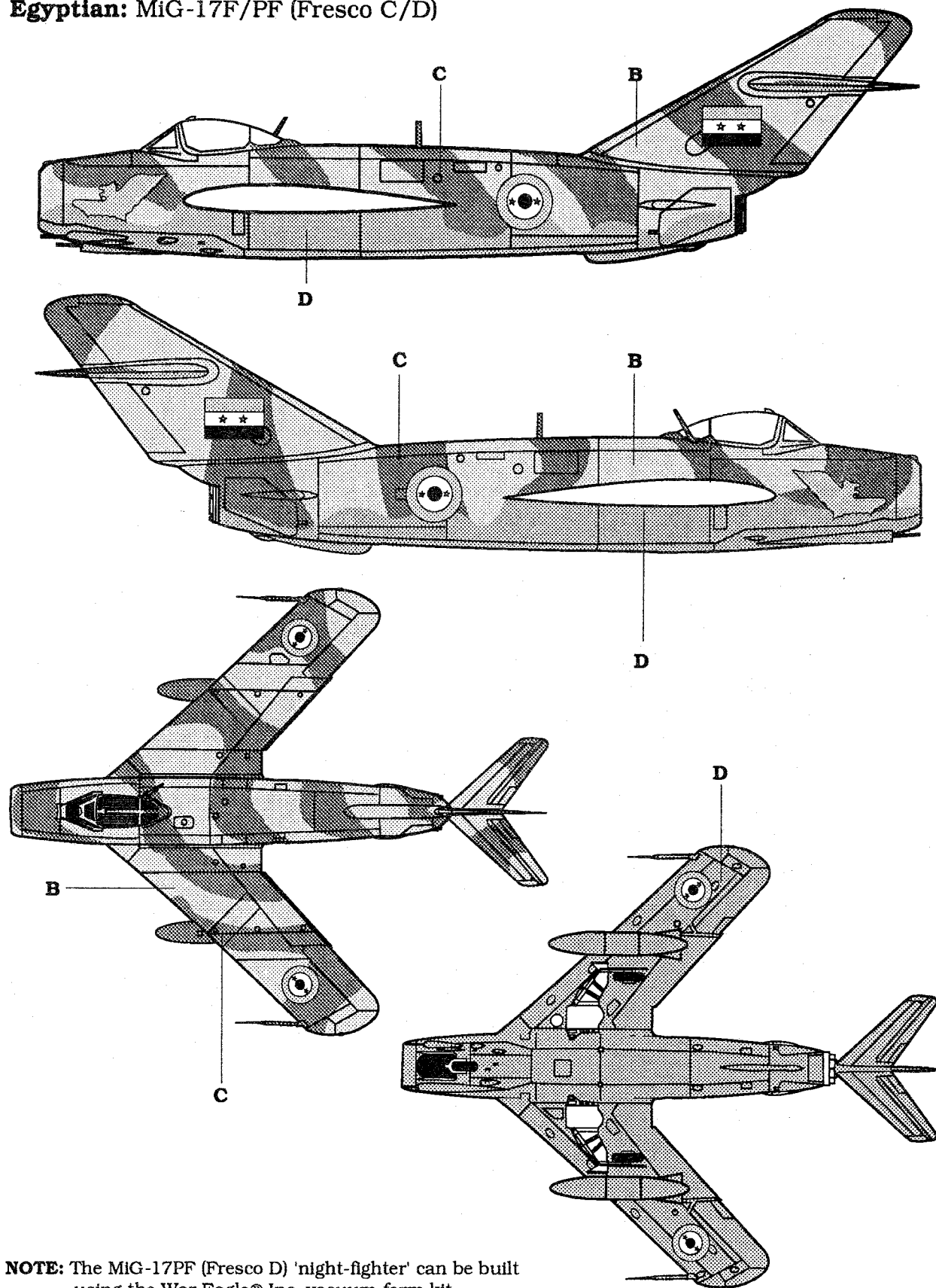

NOTE: The MiG-17PF (Fresco D) 'night-fighter' can be built using the War Eagle® Inc. vacuum-form kit.

North Vietnam: MiG-17F (Fresco C)

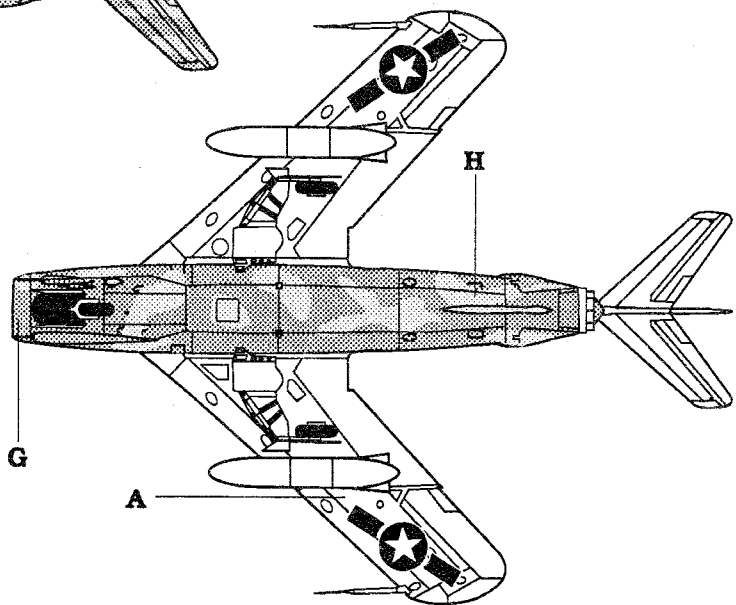
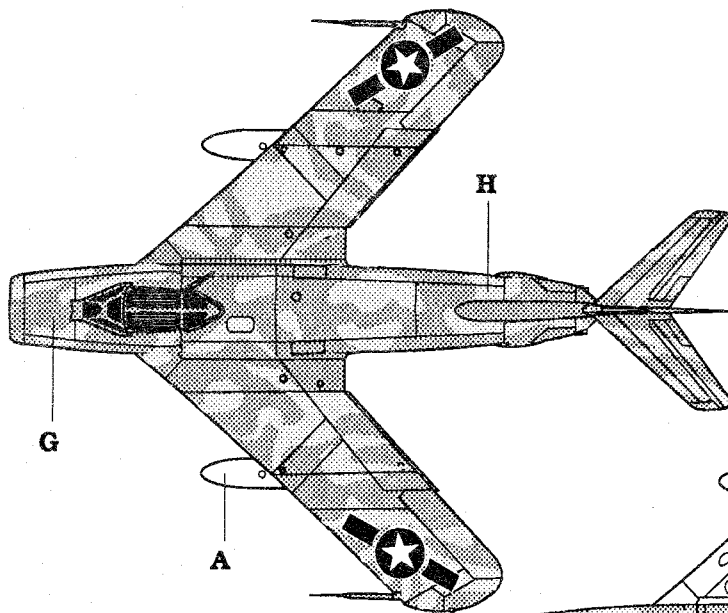
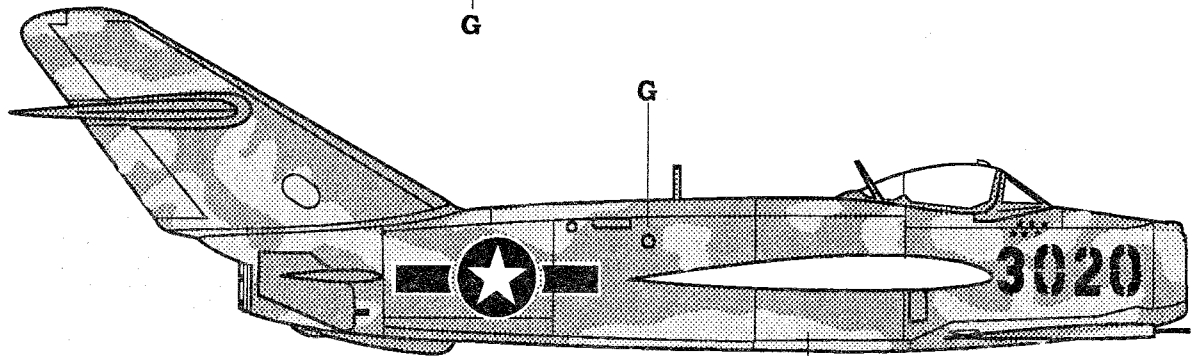
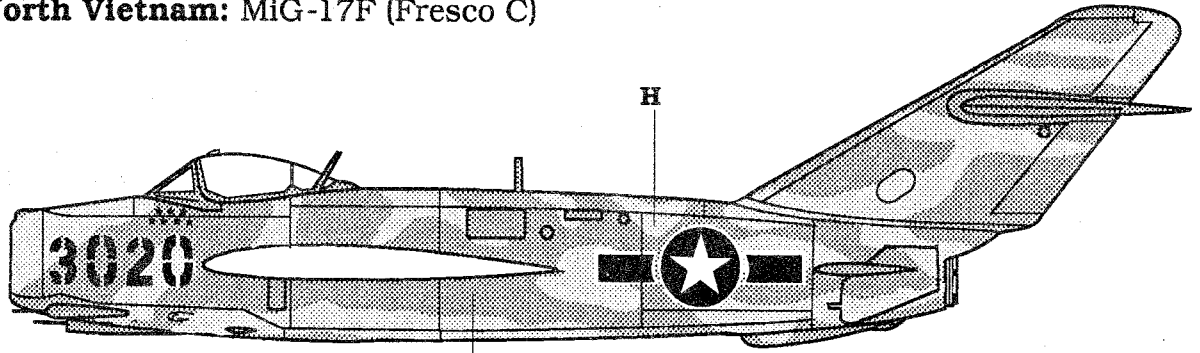

Ugandan: MiG-17F/PF (Fresco C/D)

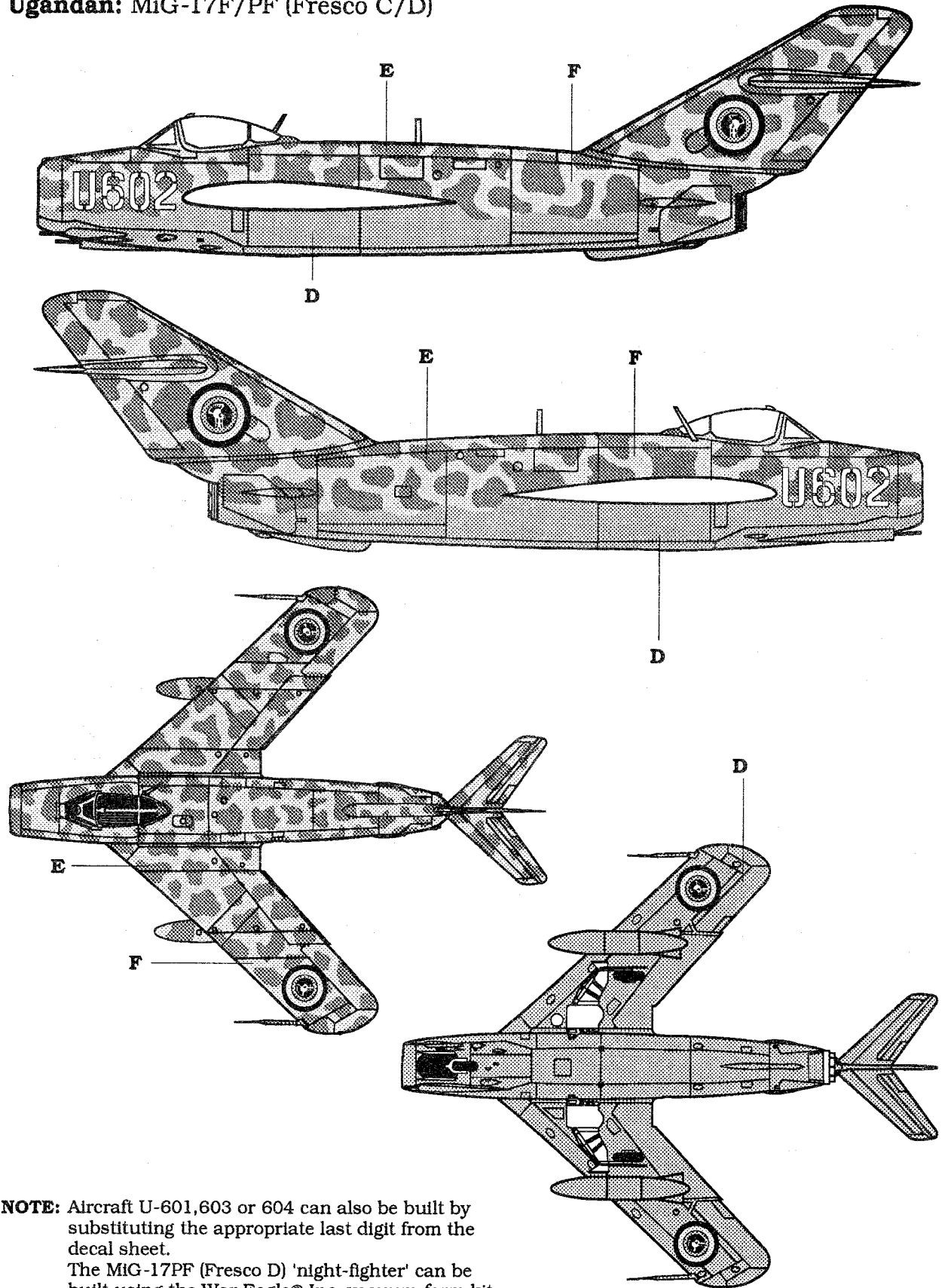

NOTE: Aircraft U-601,603 or 604 can also be built by substituting the appropriate last digit from the decal sheet.
The MiG-17PF (Fresco D) 'night-fighter' can be built using the War Eagle® Inc. vacuum-form kit.

Afganistan: MiG-17F (Fresco C)

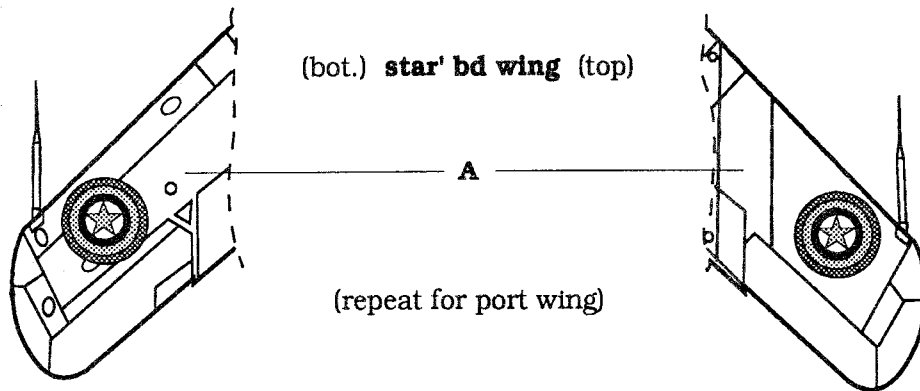
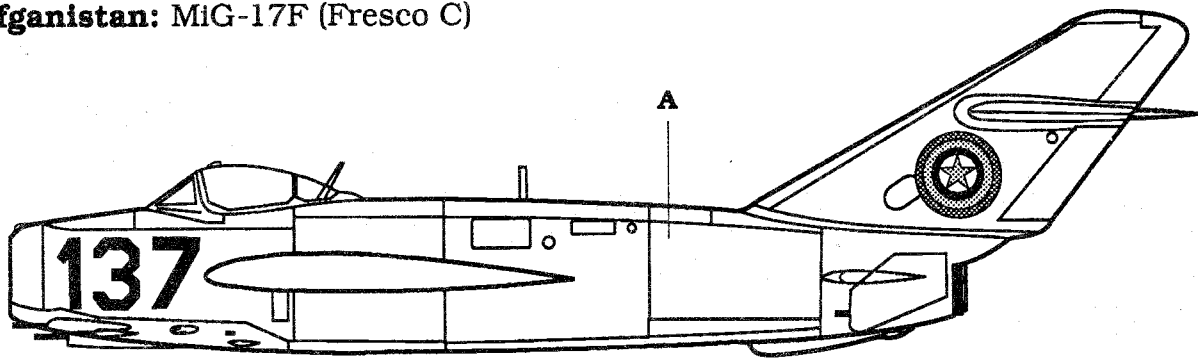

East Germany: MiG-17F/PF (Fresco C/D)

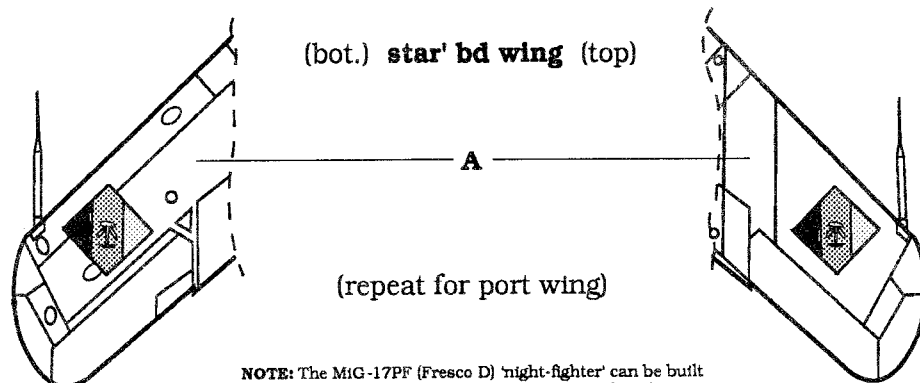
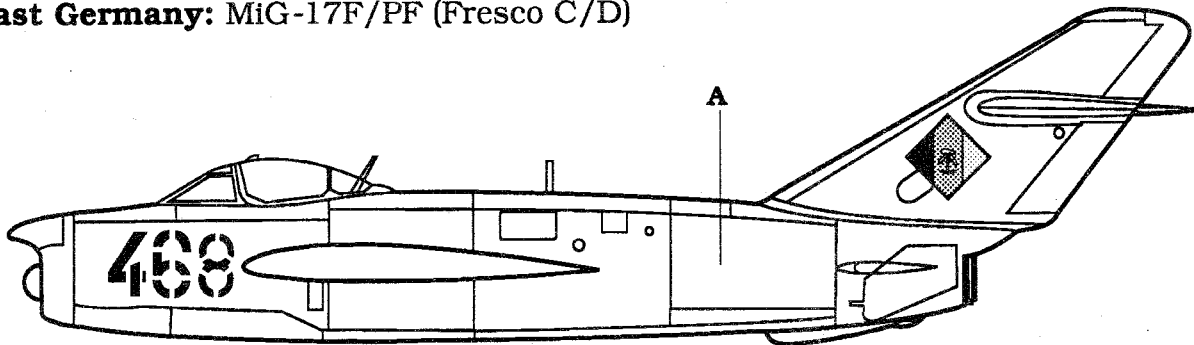

NOTE: The MiG-17PF (Fresco D) 'night-fighter' can be built using the War Eagle® Inc. vacuum-form kit.

Nigeria: MiG-17F (Fresco C)

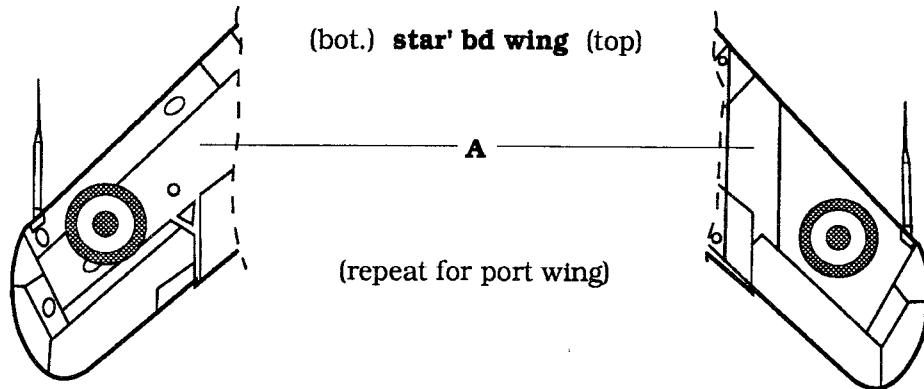
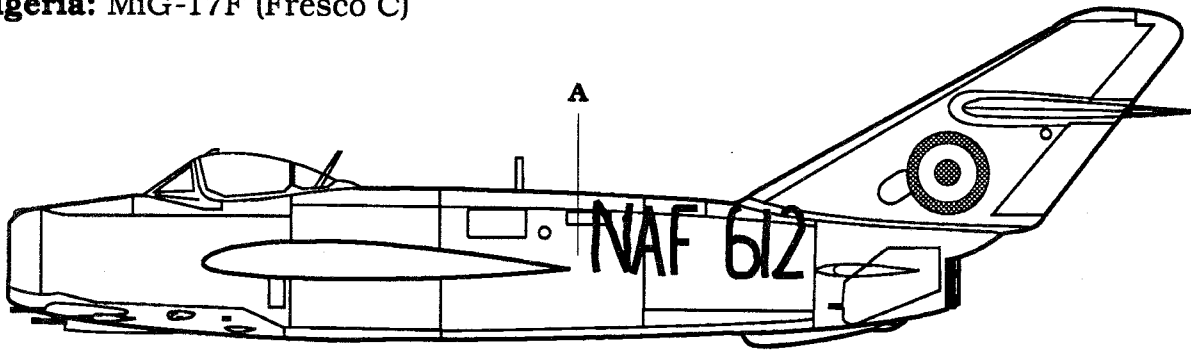

alternate fuselage markings

