

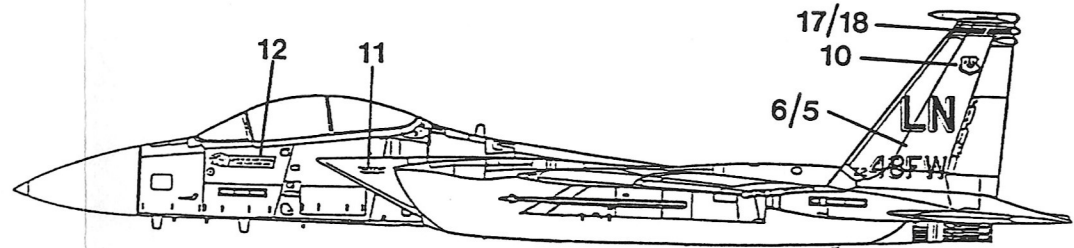

F-15E-50-MC 90-0248/LN 48FW October 1992

Standard FS36118 Gunship Grey overall

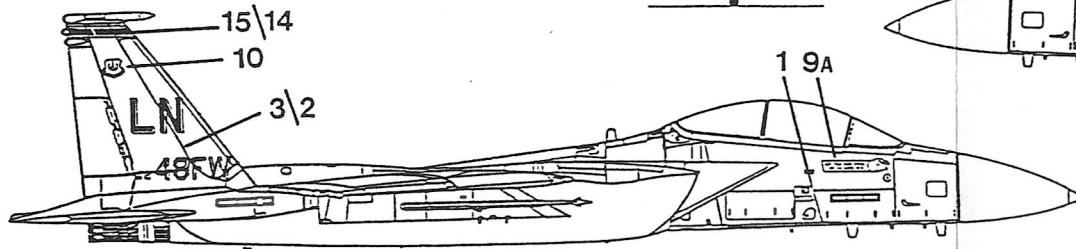
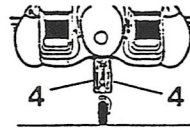

Note: In May 1992 the Commander and Crew Chief names were as decals nos. 8/9 which were located in the positions shown for nos. 12/9A. For a short time no CO name was carried, no. 7 instead of no.8.

F-111F 72-448/LN 48FW May 1992

Standard SEA camouflage of FS30219 Tan, FS34079 Green, FS34102 Green with black undersurfaces and radome.

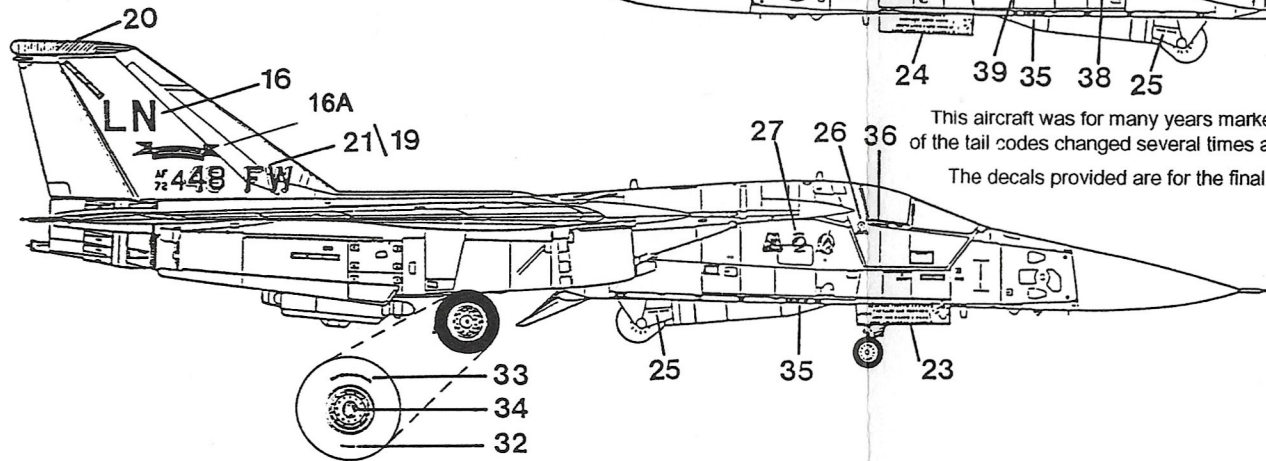
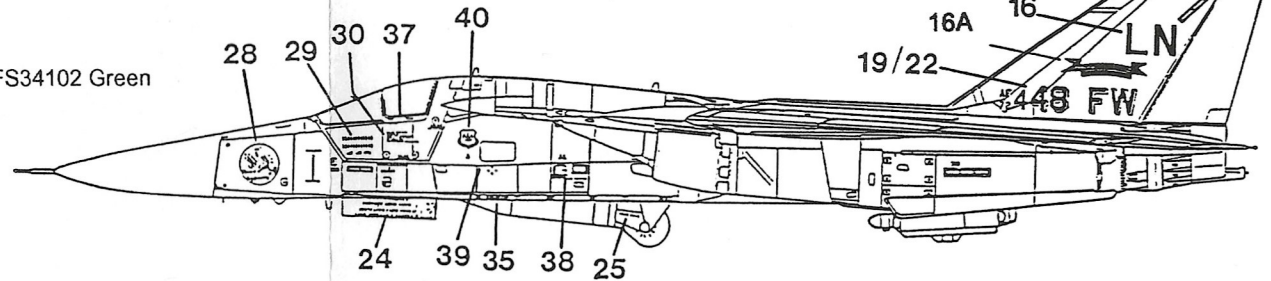

This aircraft was for many years marked with the Wing Commanders name and over these years the style of the tail codes changed several times and the Miss Liberty badge on the nose also varied as it was repainted. The decals provided are for the final markings carried at the end of it's career prior to it's return to USA

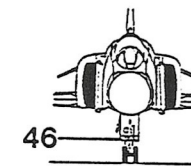

F-4D 65-685/LN 48TFW August 1975
Standard SEA camouflage of FS30219 Tan, FS34079 Green, FS34102 Green with FS36622 Grey undersurfaces.

XTRACOLOR PAINTS FOR THESE AIRCRAFT

- X102 FS10219 Tan X110 FS14079 Forest Green
- X116 FS14102 Green X130 FS16118 Gunship Grey
- X140 FS16622 Light Grey X12 Black X504 Exhaust

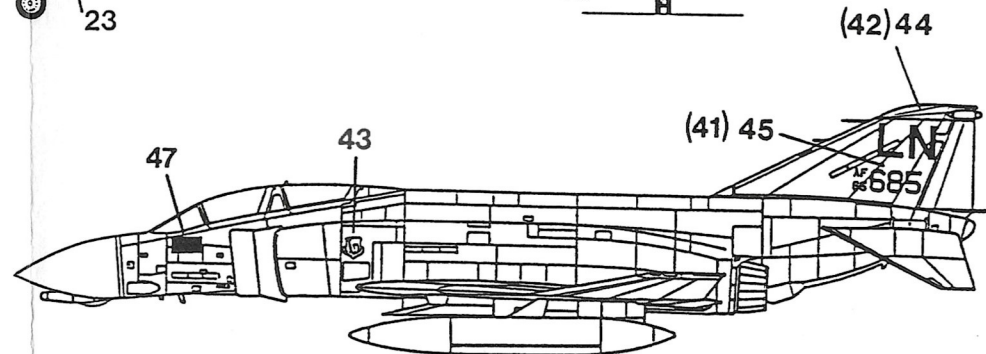

XTRADECAL GRATEFULLY ACKNOWLEDGE THE ASSISTANCE OF GARY WENKO IN THE PREPARATION OF THESE DECALS.

LN

1
11
U.S. AIR FORCE F-15E OR A/C
SERIAL NO. 90-00000
PROPERTY OF THE U.S. AIR FORCE
AF 90-00000

XO15-48
TRADEGAL

9
DEDICATED CREW CHIEF
TS/1 JOHN KINTA

48TH FW COMMANDER 7

8
48TH FW COMMANDER
COLONEL MIKE SMITH

4
0 0
2 2
4 4
8 8

LN

2
AF 90 2
48FW

16
LN

9A
DCO: TSGT JOHN KINTA
ACC: A/C JAMES INCH

12
A/D/C: COL KURT ANDRESEN
NSO: CAPT CHIP LINE

5
AF 90 2
48FW

16
LN



18

22

AF 72 448 FW AF 72 448 FW



24
STAND CLEAR 25 STAND CLEAR



23



20



47

PILOT
CAPT HIGH
CREW CHIEF
SGT LAUTZ

44



29
35
39
30
U.S. AIR FORCE F-15E OR A/C
SERIAL NO. 90-00000
PROPERTY OF THE U.S. AIR FORCE
AF 90-00000



26



36

37



0685

46



38



33



34

40

41

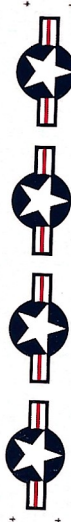

45