

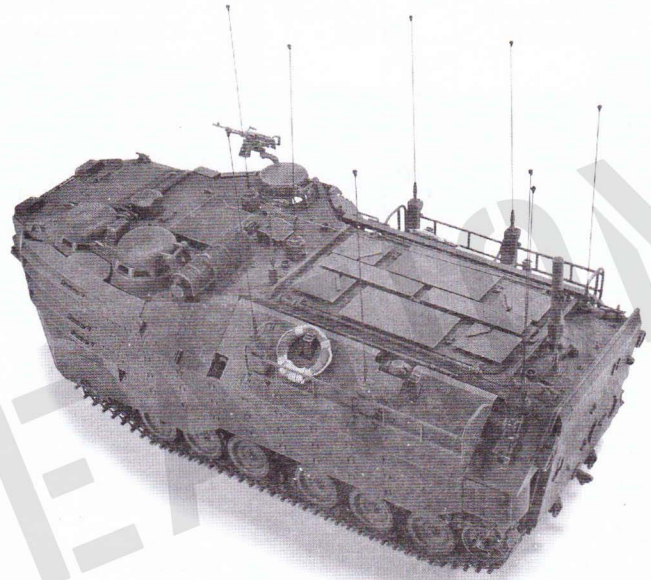

AAV7-C1 RAM/RS w/EAAK



There is only one amphibious vehicle, namely LVTP5, saw service in USMC after WWII up to early 70s. In 1964, USMC required a new amphibious vehicle design to replace LVTP5. By 1966, Food Machinery Corporation's submission was approved, and prototype LVTPX12 was completed in the following year, submitted to USMC for trial. It completed all the tests and was designated as LVTP7 in 1969.

The LVTP7 adopts very different designs than its predecessors, the LVTP5. Firstly, personnel entry is at the rear of the vehicle, reduced concerns on front entry in combat. The main propelling action in the water was by a water jet on either side of the vehicle, outperforms LVTP5 both on land and water. US DoD awarded a contract to FMC for 942 LVTP7s in 1970. They started to enter USMC service since 1972, and replaced all LVTP5s by 1974.

The 2nd wave of upgrade plan for AAV7A1s commenced in 1987, aiming to improve survivability and combat abilities. Newly installed Up-Gunned Weapon Station (UGWS), which was armed with both a 12.7 mm M2HB machine gun and a Mk19 40 mm grenade launcher, to against adversary personnel and soft skin vehicles. In addition, lighter tracks were adopted. Next upgrade program, known as AAV7A1 RAM/RS, saw services in USMC, RoC (Taiwan) Marines and Italian Marines.

二次大戰結束後至七零年代初期，美國海軍陸戰隊僅有一款LVTP5系列的履帶式兩棲登陸車輛進入部隊服役。在1964年陸戰隊要求開發一種新的兩棲車輛來取代LVTP5。1966年此案由FMC公司的設計獲得採用，1967年完成原型車LVTPX12的製作，並交由陸戰隊測試，至1969年車輛通過測試，被正式命名為LVTP7。

LVTP7與LVTP5在配置上有了很大的差異，所搭載的兵員改為由車尾出入，改善了戰鬥時由車首出入安全的顧慮。另外LVTP7在浮渡時採噴水推進器行進，比起LVTP5採用履帶撥水的方式，在水面航速與陸地的機動性能上均超越。1970年國防部與FMC公司簽訂了942輛LVTP7的生產合約，1972年起LVTP7陸續的進入美國海軍陸戰隊服役，至1974年完成合約內容全面汰換LVTP5。1977年FMC公司再為LVTP7著手進行更換發動機等多項的性能提升，升級後的型號為LVTP7A1。同一時間美國海軍陸戰隊又再陸續新購全新的LVTP7A1，至1983年這批經過升級或新購的LVTP7A1被改稱為AAV7A1。

1987年AAV7A1開始第二次升級計畫，目的在增加車輛在作戰時的生存與戰鬥能力。新設計的單人砲塔安裝了Mk 19 40mm榴彈發射器與M2 HB 12.7mm機槍，強化了對人員與輕裝甲車輛的攻擊能力。部分AAV7A1加掛了額外的EAAK間隙裝甲，能有效的抵禦小口徑穿甲彈的攻擊，此外尚更新了輕量化的履帶，經過此第三代升級的車輛被稱為AAV7A1 RAM/RS，除了美國海軍陸戰隊之外，目前並在中華民國與義大利的軍隊中服役。

Illustration:圖示說明



Method For Applying Decals:

1. Clean Model Surface With Wet Cloth.
2. Cut Out Of Decal Sheet And Dip Them In Warm Water For 15 Seconds.
3. Place it on proper position on model.
4. Slide off base paper leaving decals On Model With Wet Finger Tip.
5. Move Decals To Exact Position, Push Out Excess Water Under Decal With Soft Cotton Cloth.
6. When Decals Get Dry Then Complete.

水貼紙使用說明:

1. 將模型表面擦乾淨
2. 將貼紙剪下泡入溫水中浸泡約15秒
3. 將泡濕之貼紙取出置於欲貼處旁
4. 用指尖輕推貼紙表面使其滑出底紙
5. 將貼紙調整至適當位置並輕擦拭水份
6. 待其自然乾燥後即完成

Color list: 塗料表

Color	Brand	Gunze Sangyo			Humbrol	Revell	Lifecolor
		Hobby Color	Mr.Color	Mr.Color Spray			
Bronze green	青銅綠		TC10				
Leather brown	皮革棕		TC11				
Red	紅	H3	C3	J3	19	31	UA90
RLM79 Sandy brown	黃褐	H66	C119		62	85	UA81
Steel	黑鐵	H18	C28	J28	53	91	LC65
Tar black	瀝青	H12	TC12	J33	33	8	LC02
Tire black	輪胎黑	H77	C33+C62		85	302	LC02

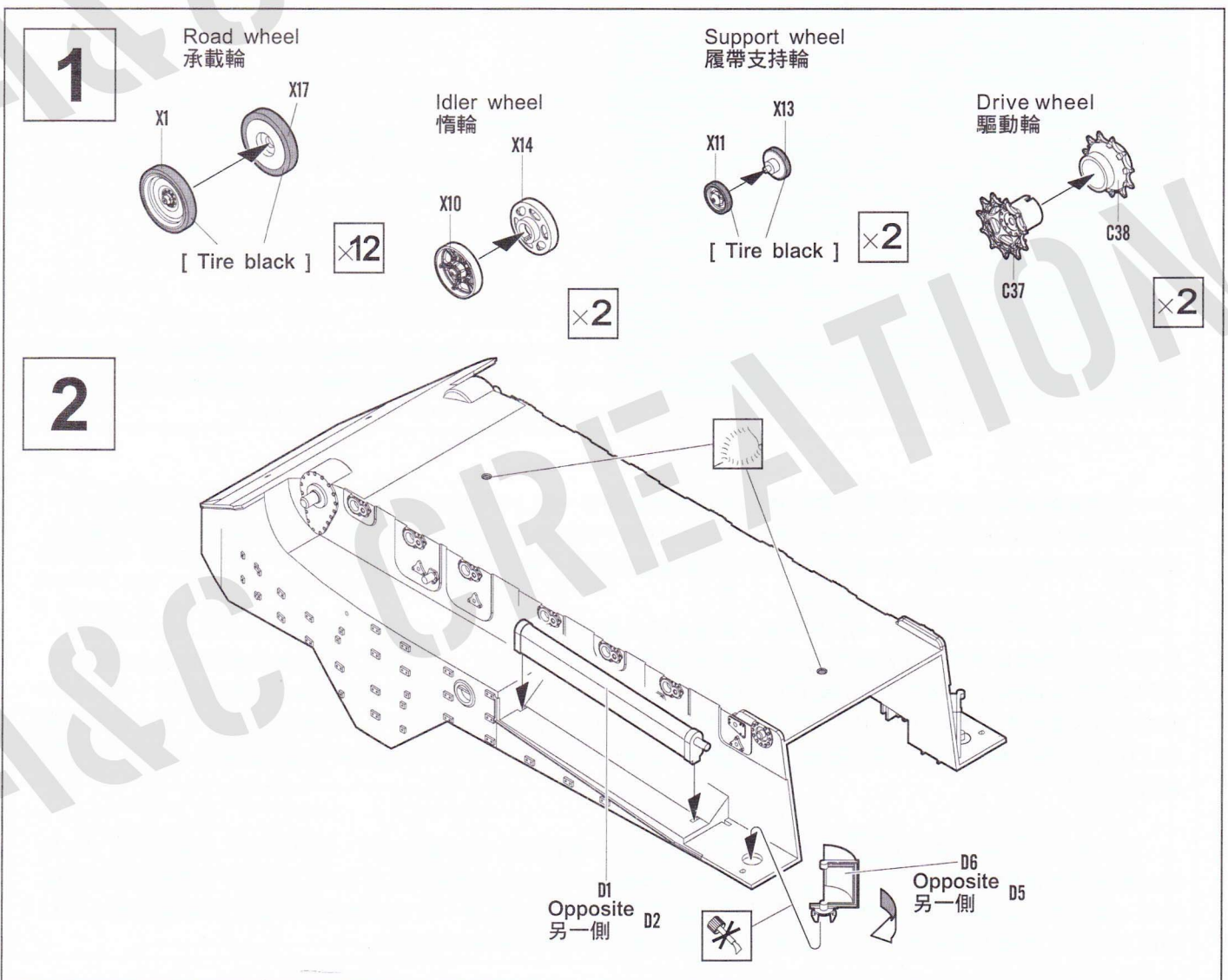

3

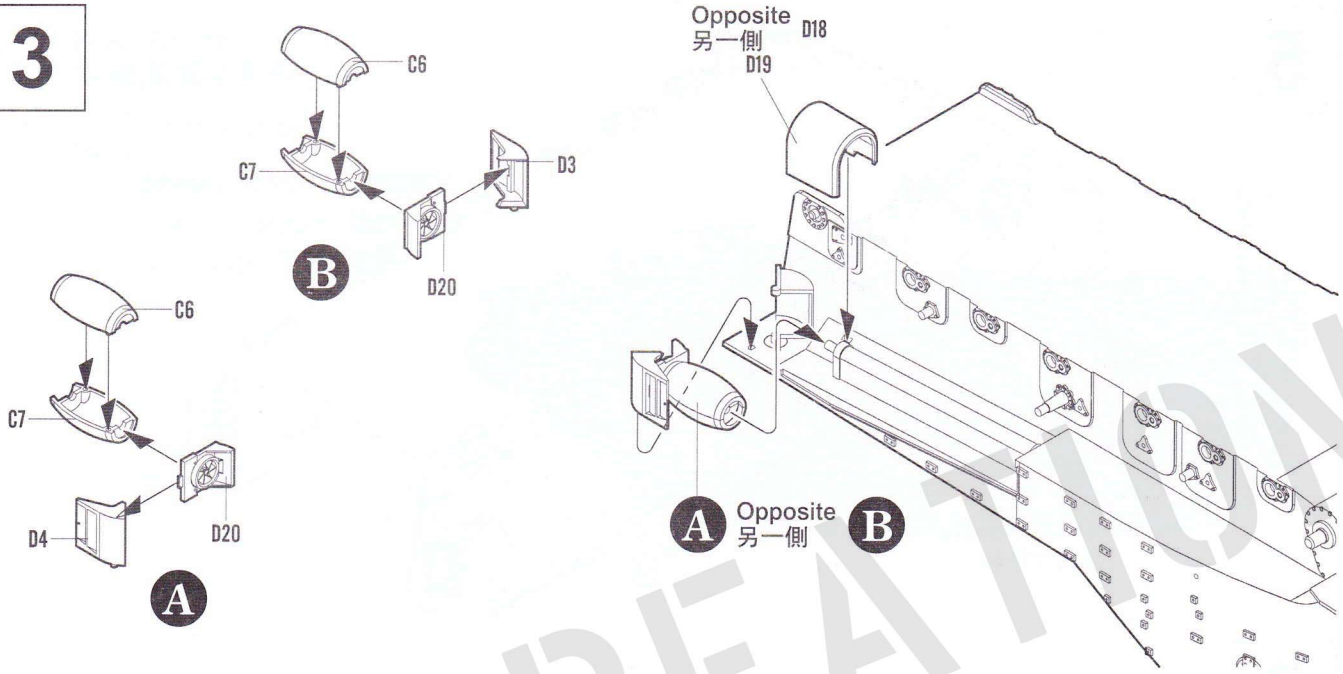

4

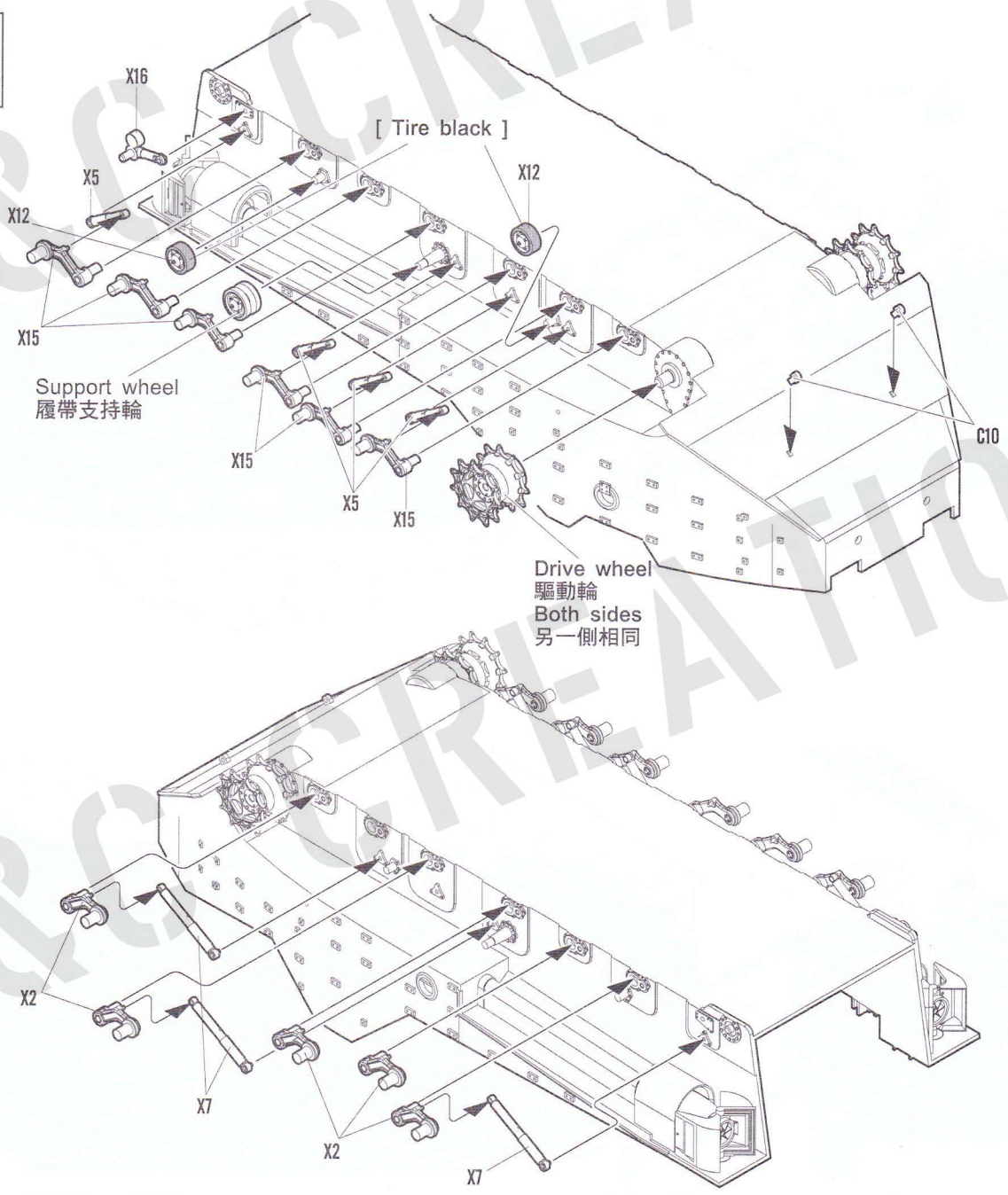

5

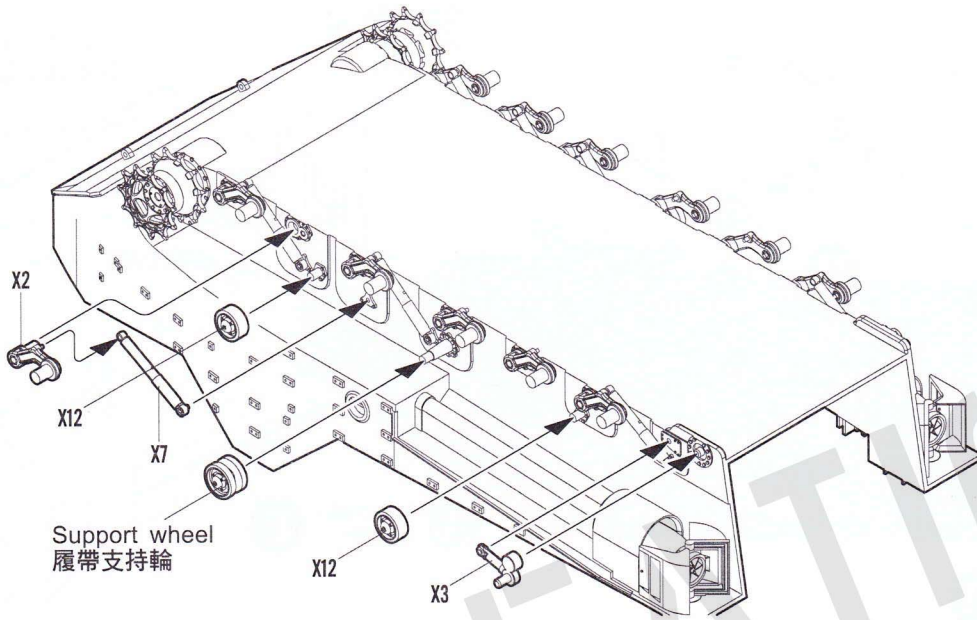

6

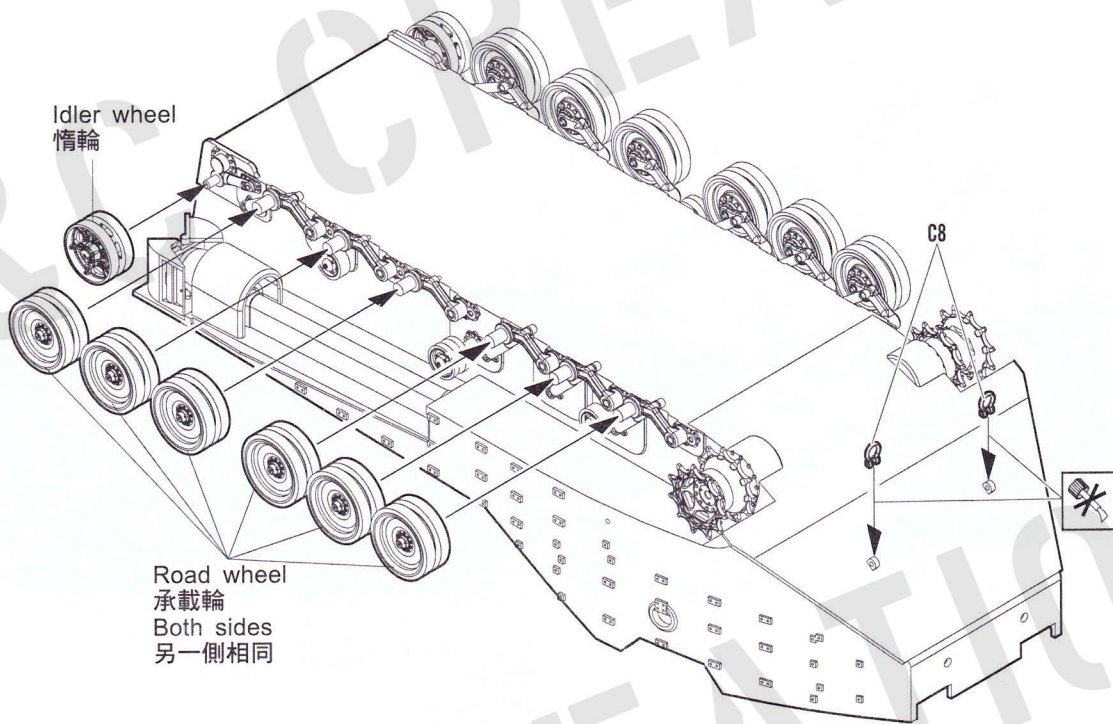

7

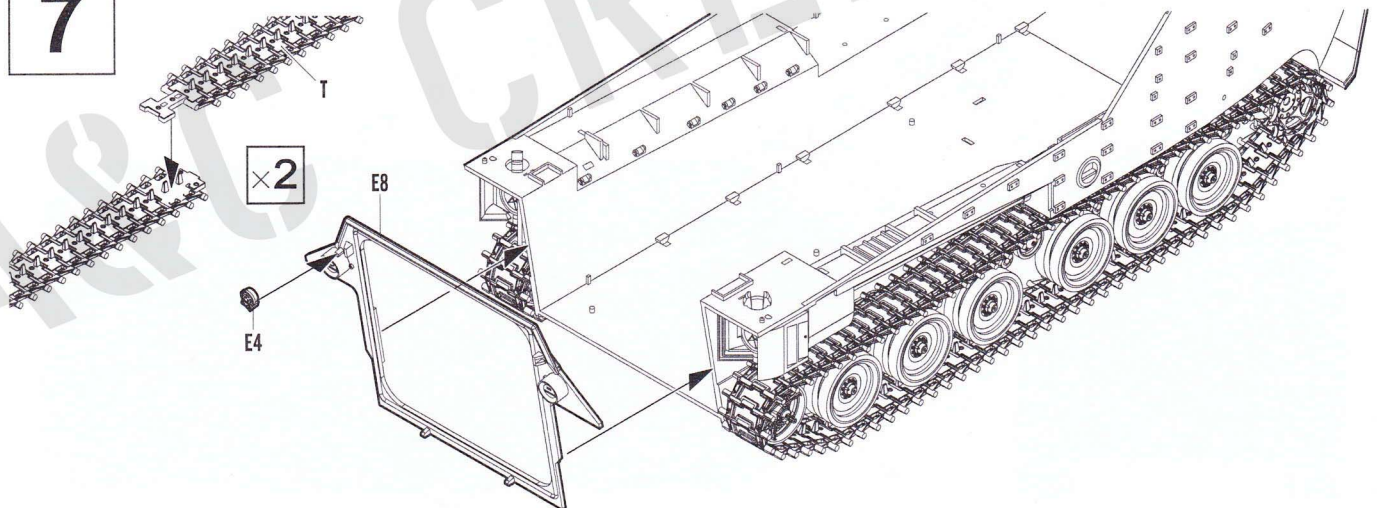

8

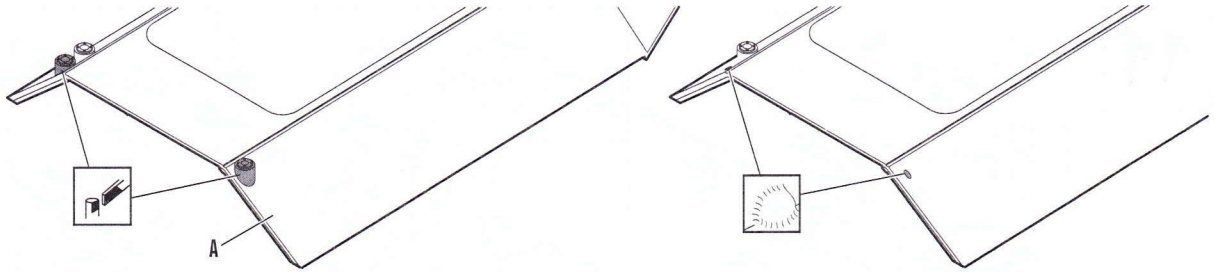

9

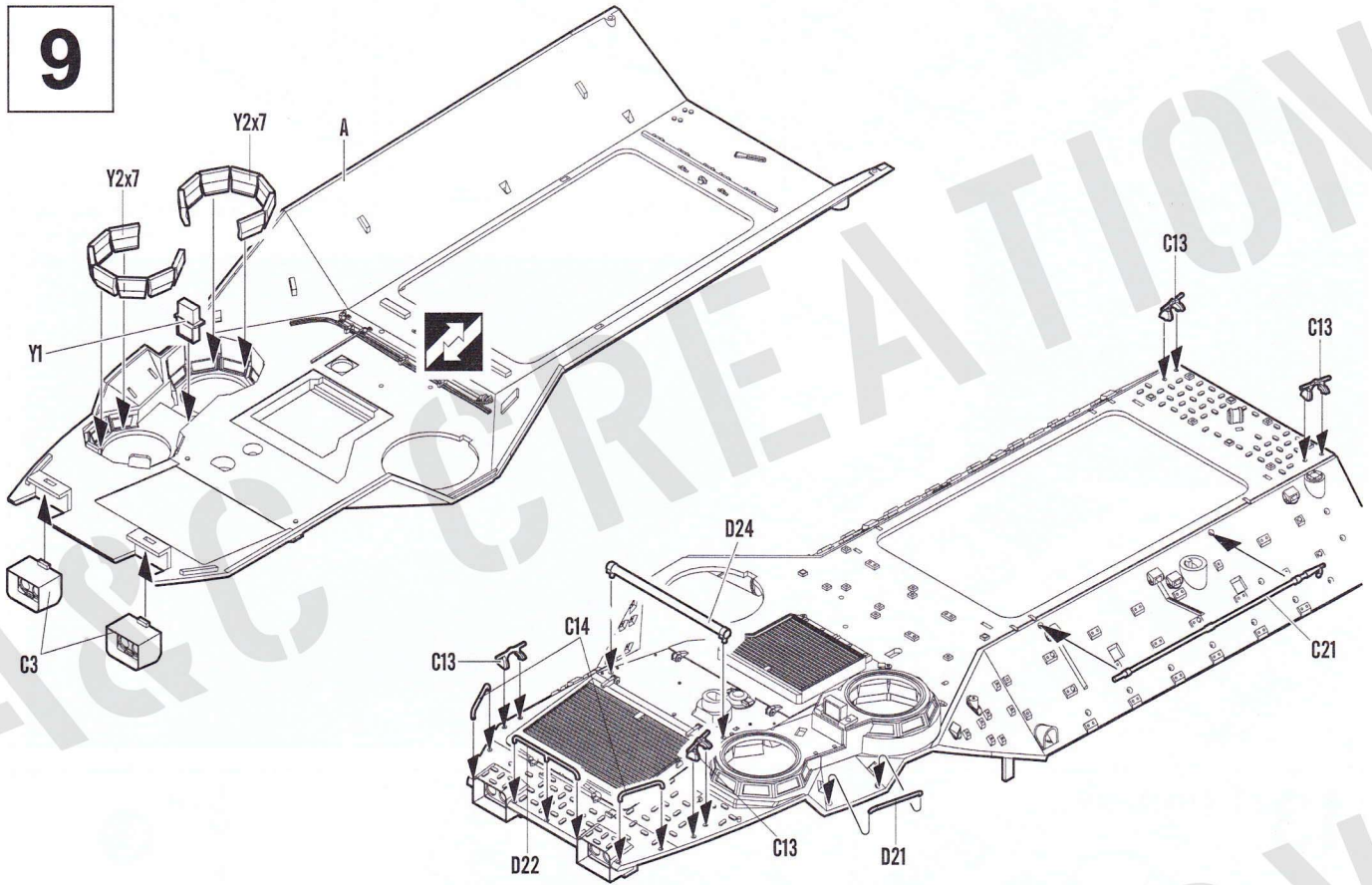

10

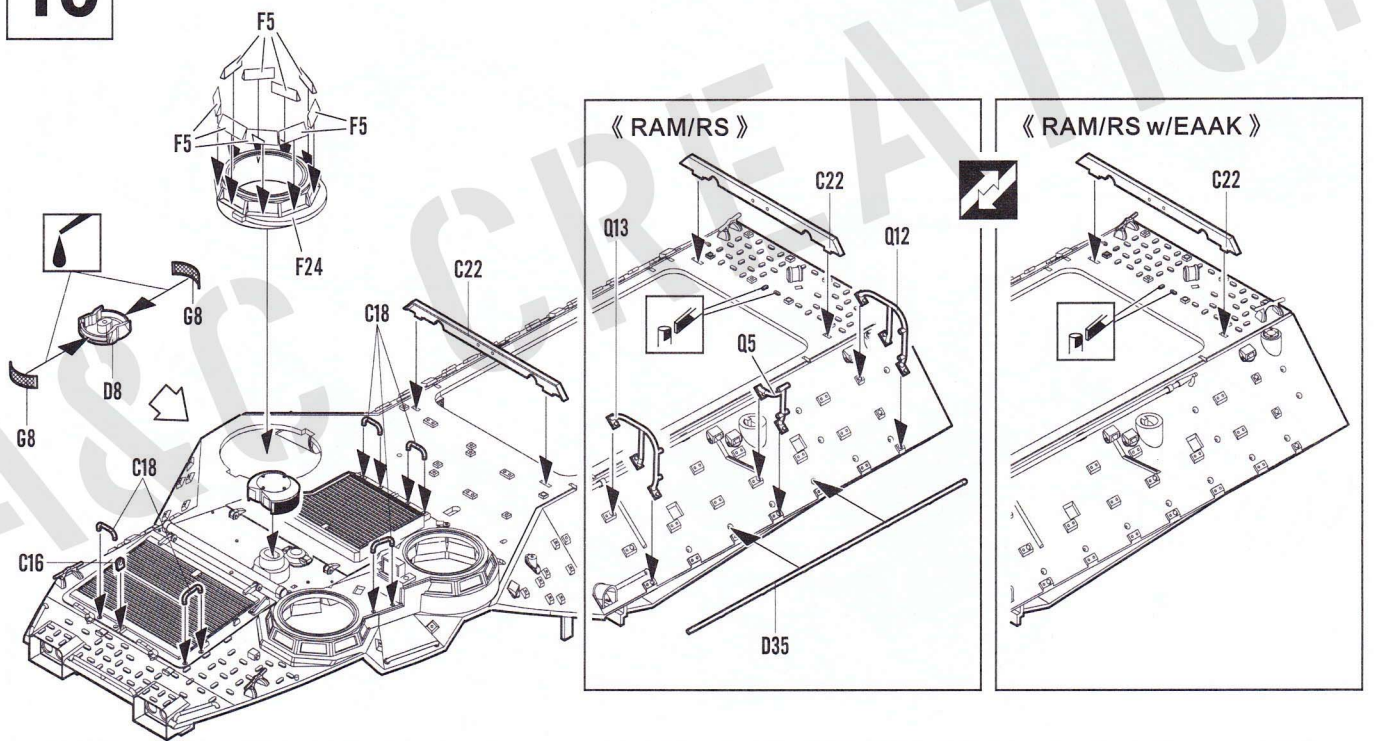

11

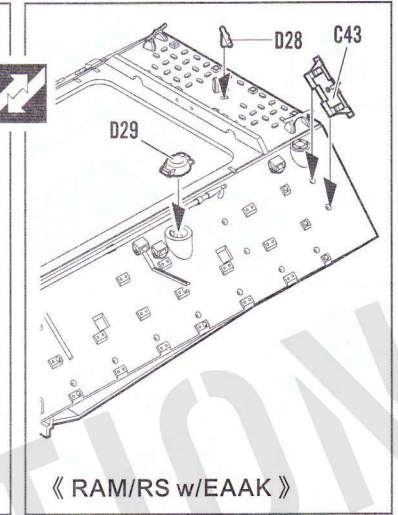
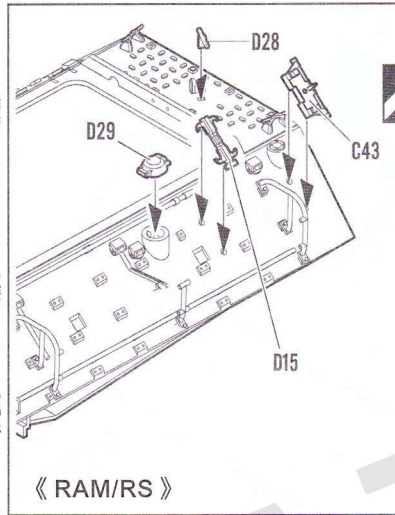
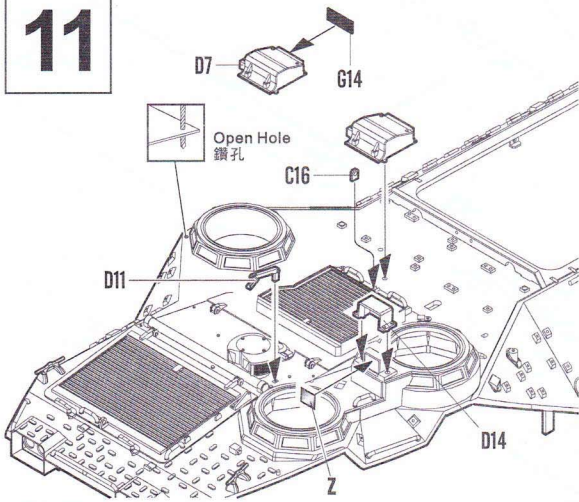

12

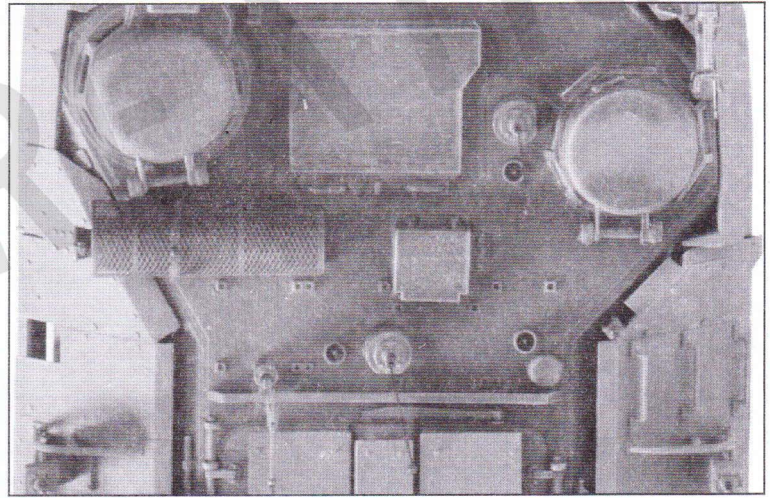
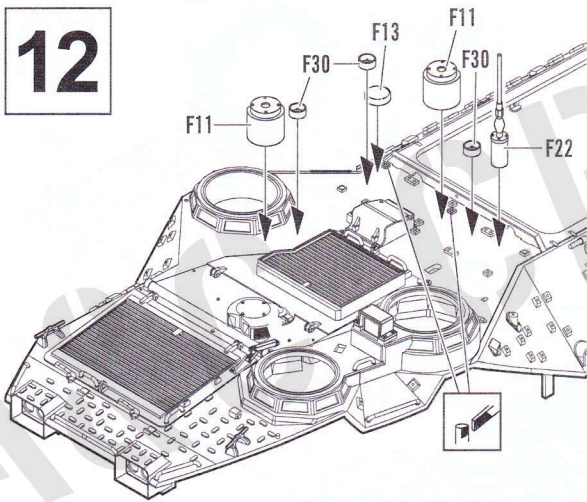

13

《 RAM/RS 》

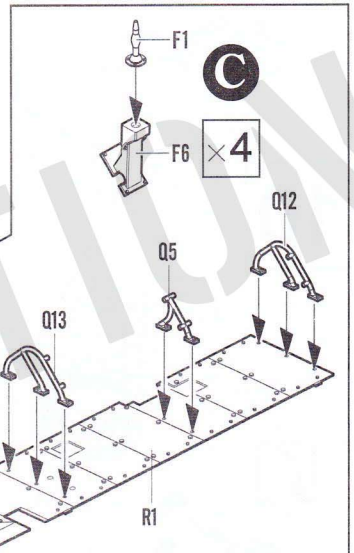
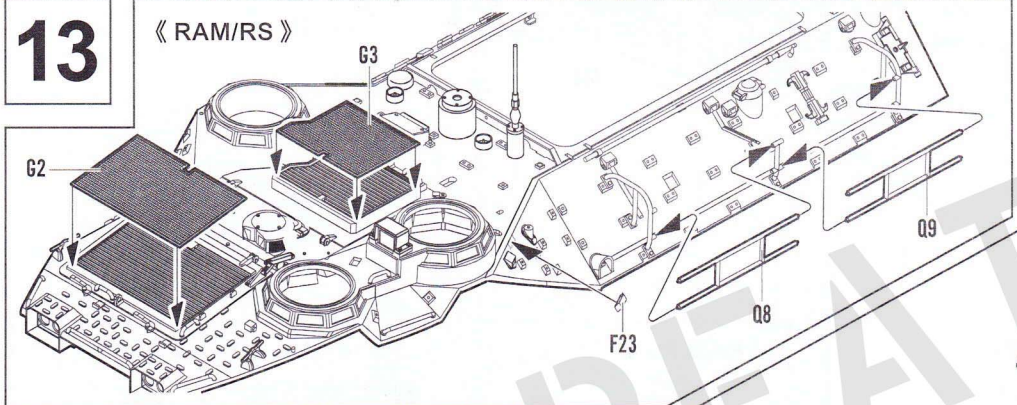

《 RAM/RS w/EAAK 》

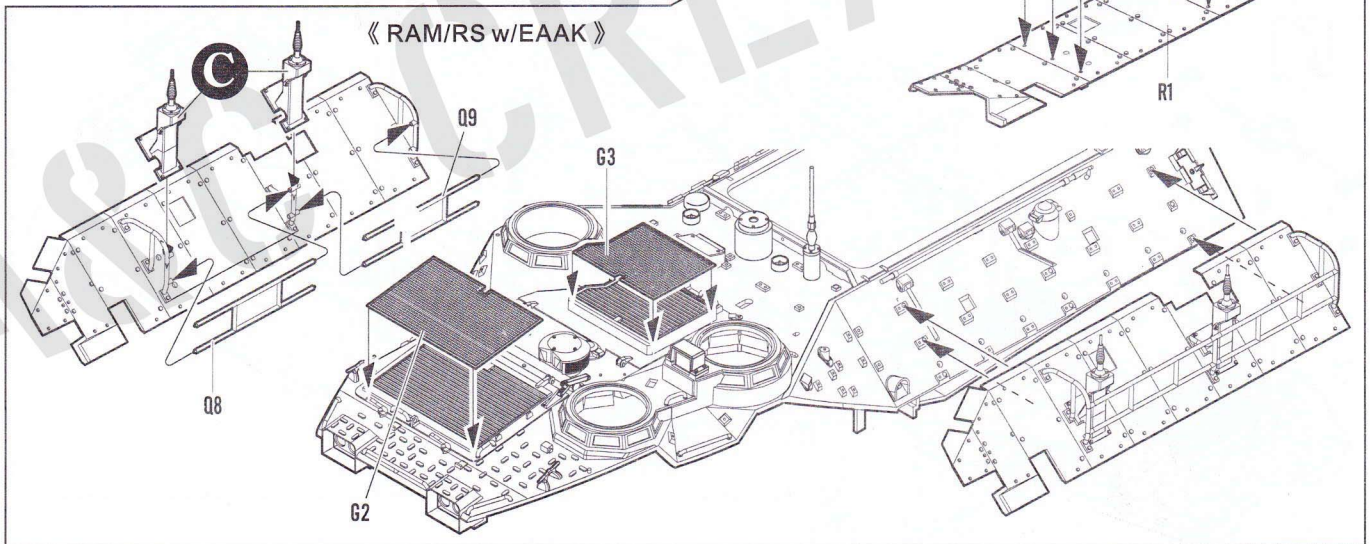

14

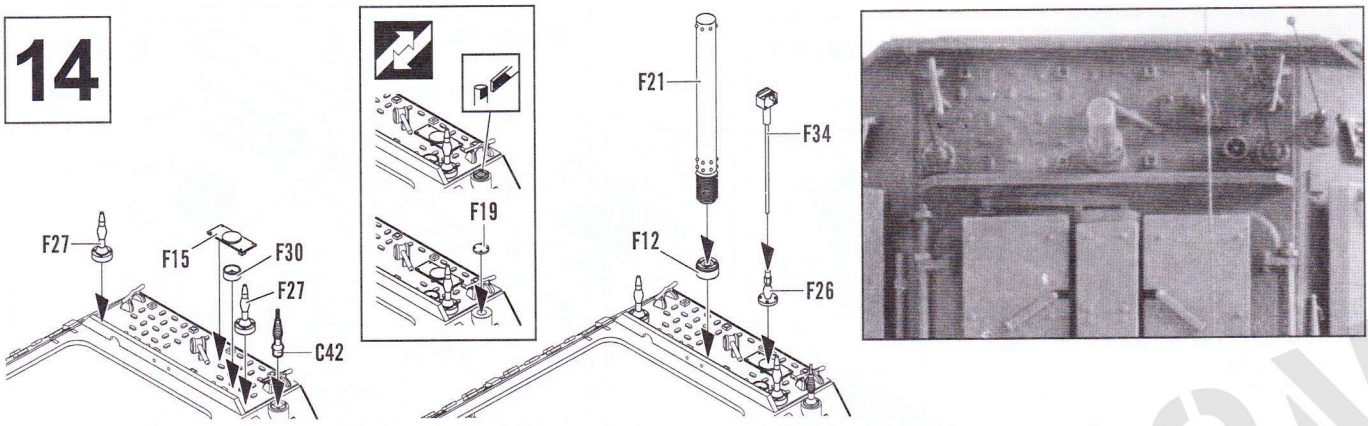

15

« RAM/RS »

D

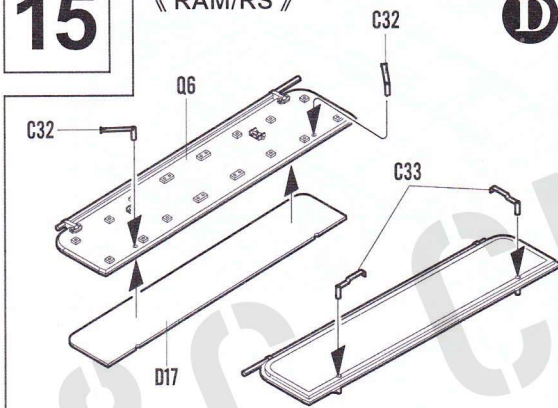

« RAM/RS w/EAAK »

E

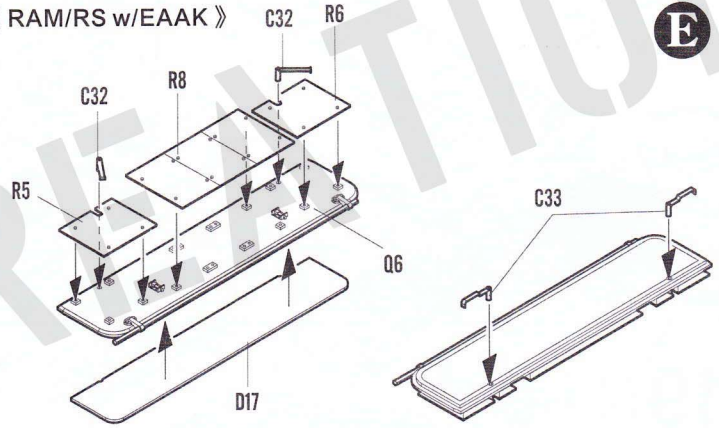

16

« RAM/RS »

D

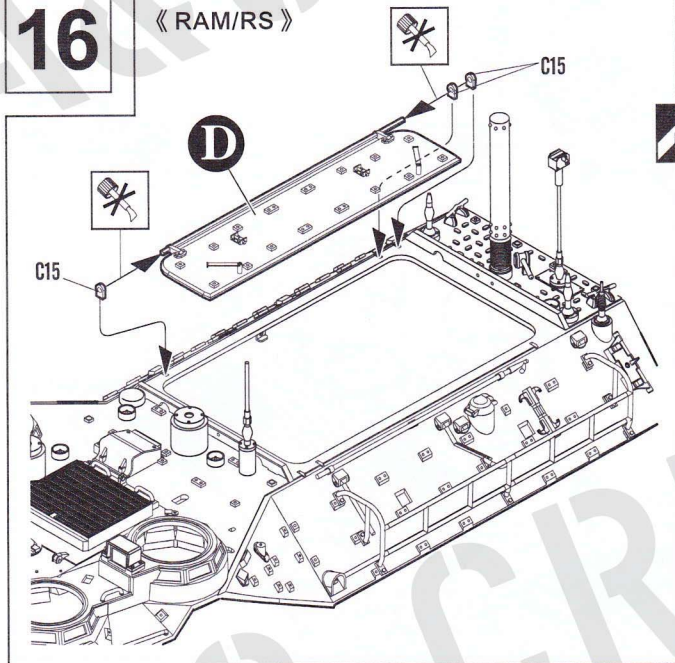

« RAM/RS w/EAAK »

E

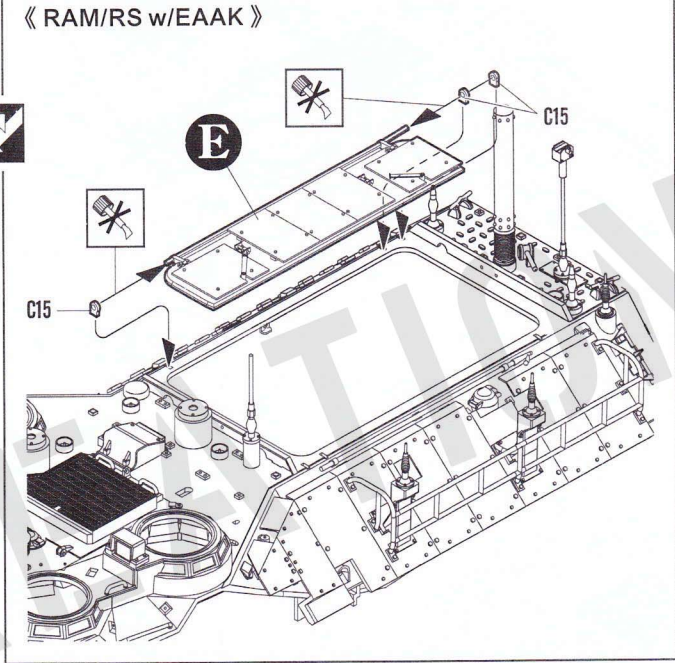

17

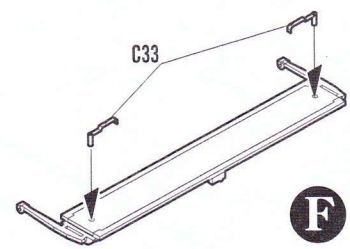
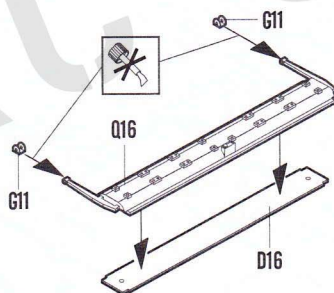

F

18

« RAM/RS »

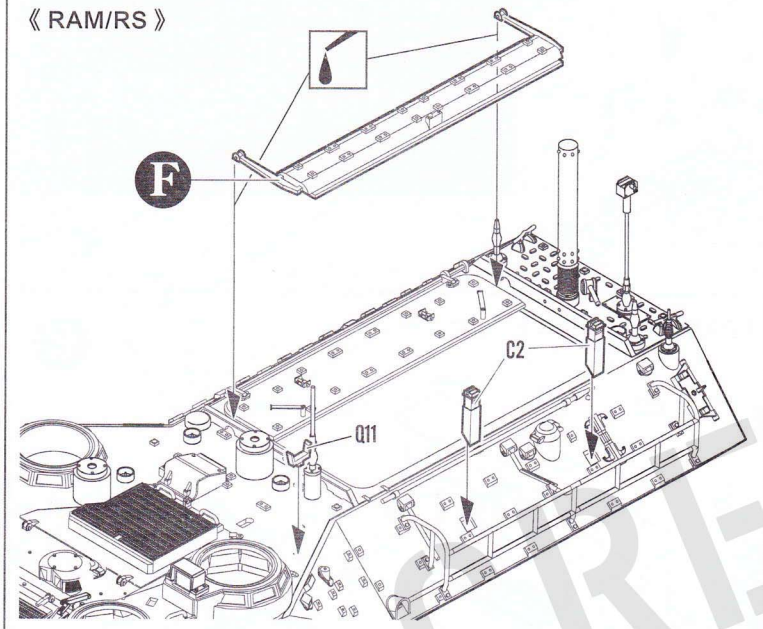

« RAM/RS w/EAAK »

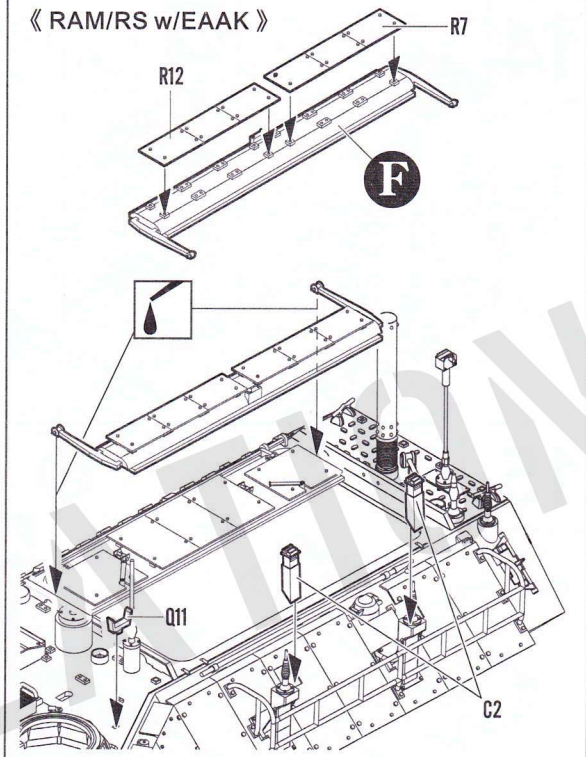

19

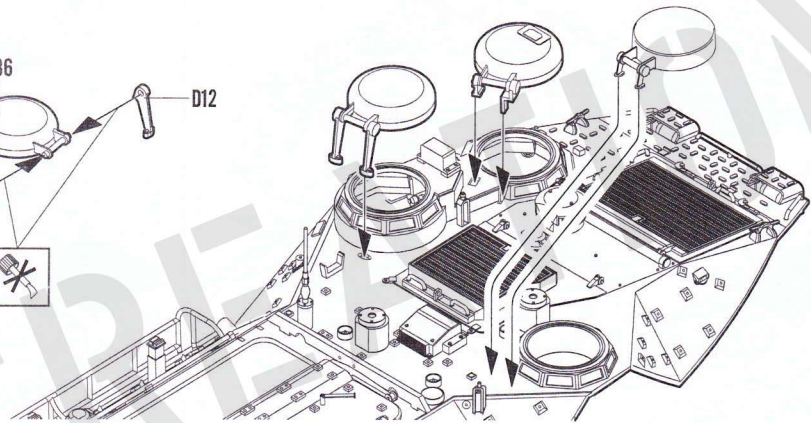
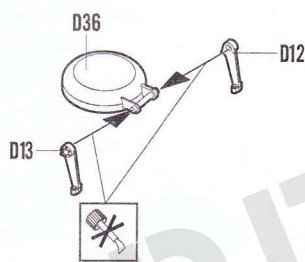
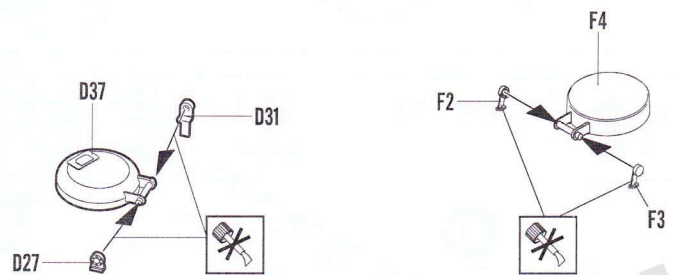
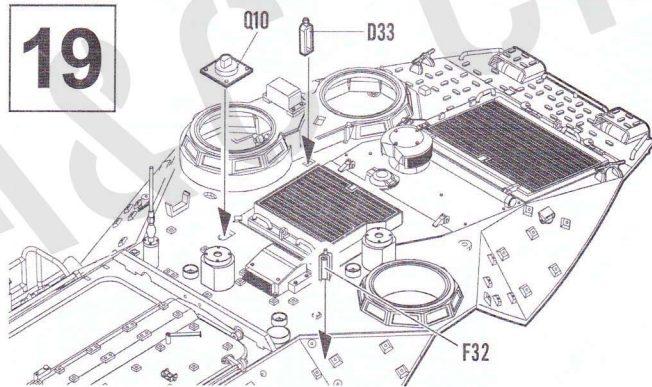

20

« RAM/RS »

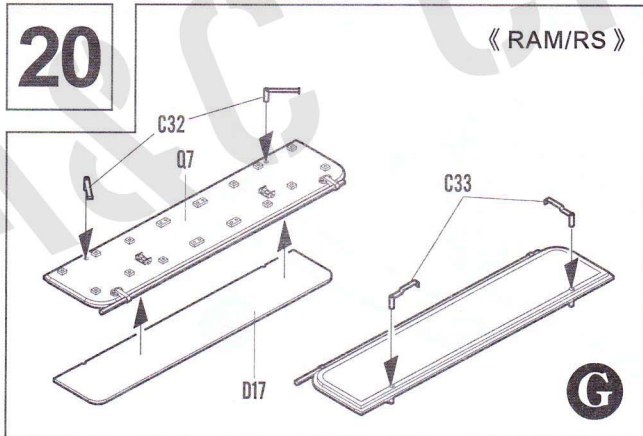

« RAM/RS w/EAAK »

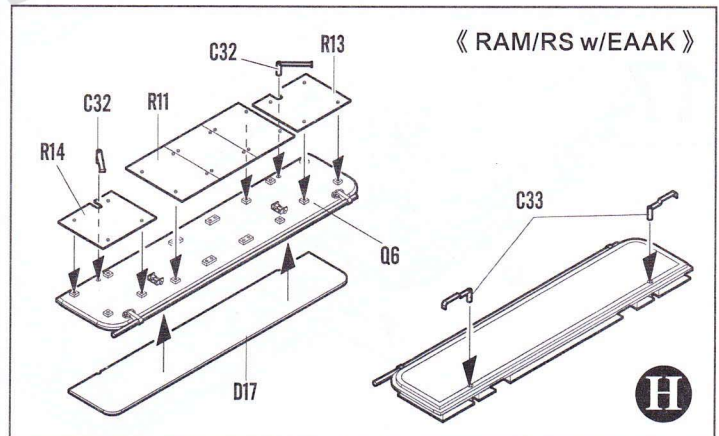

21

« RAM/RS »

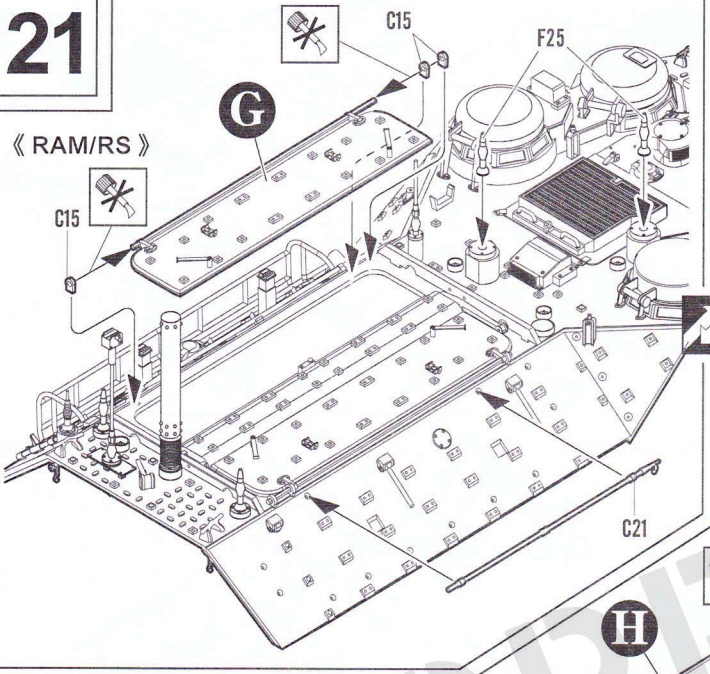

« RAM/RS w/EAAK »

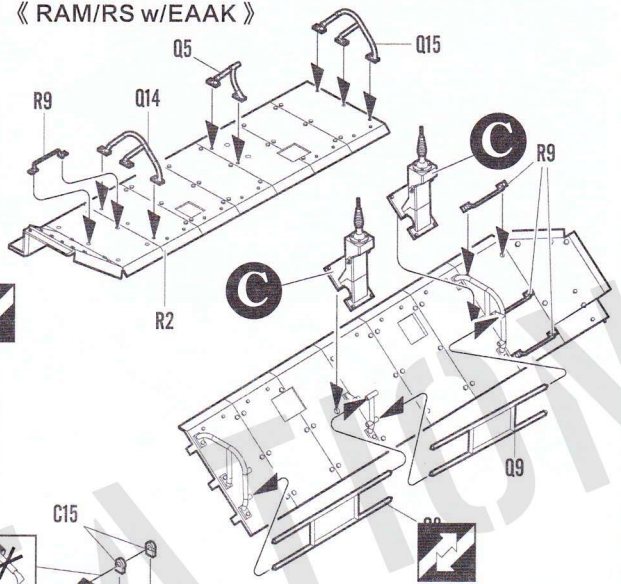

22

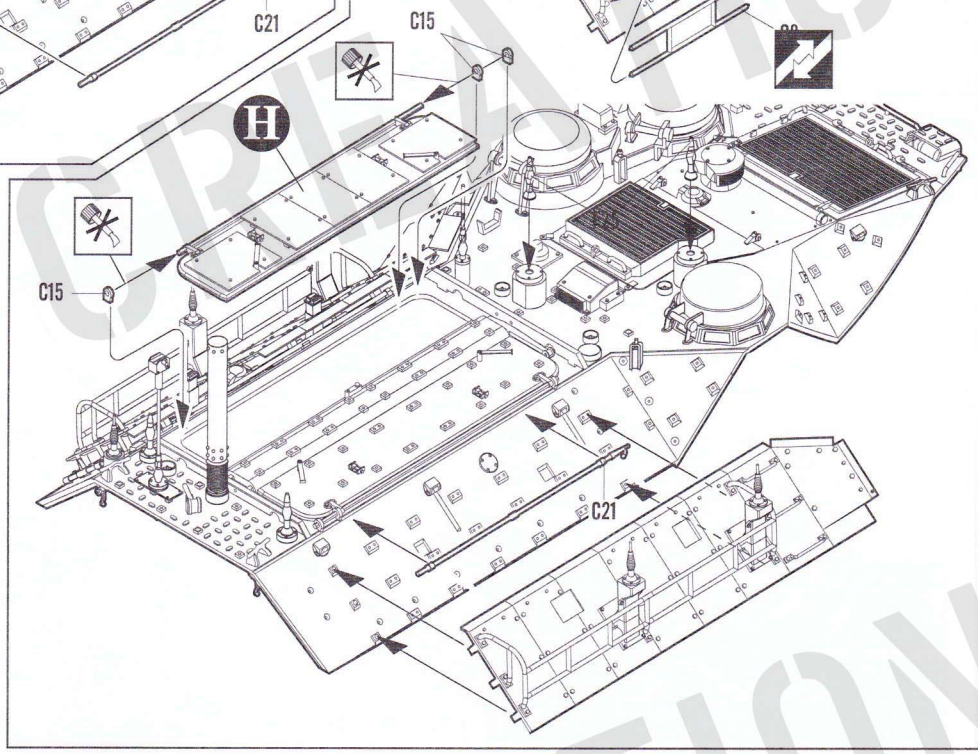
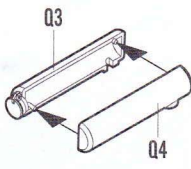

« RAM/RS »

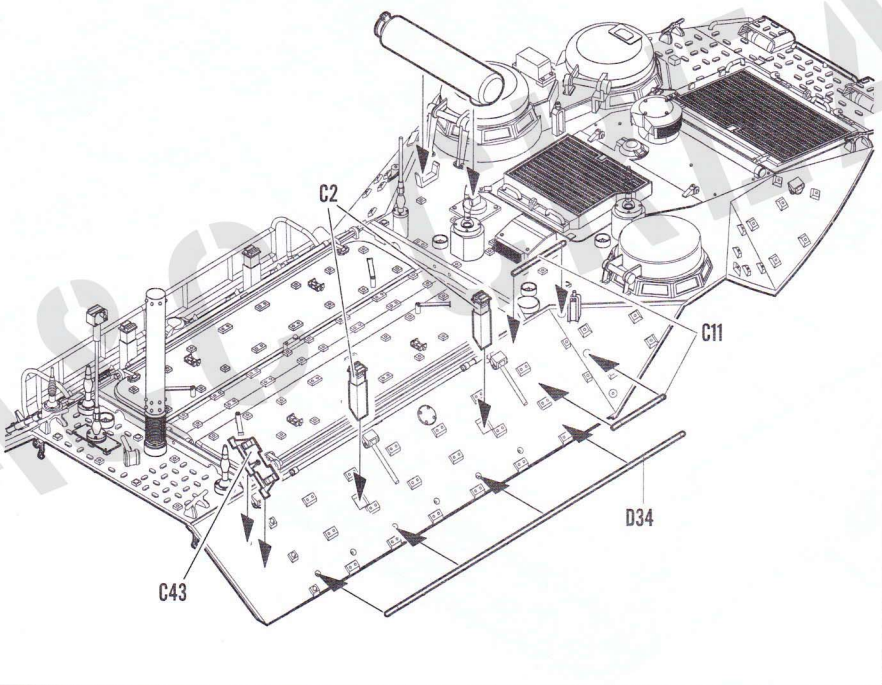

« RAM/RS w/EAAK »

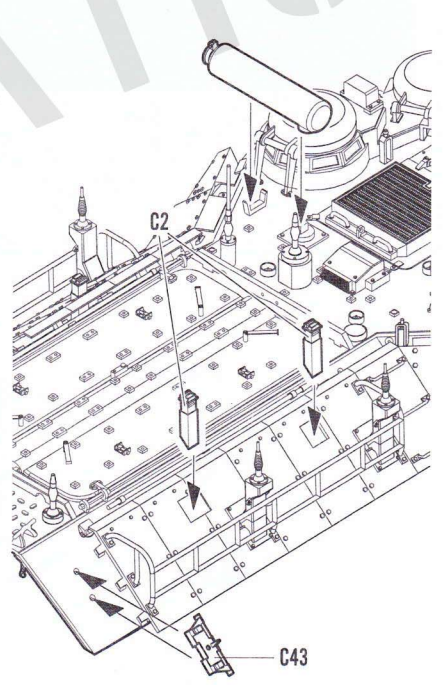

23

《 RAM/RS 》

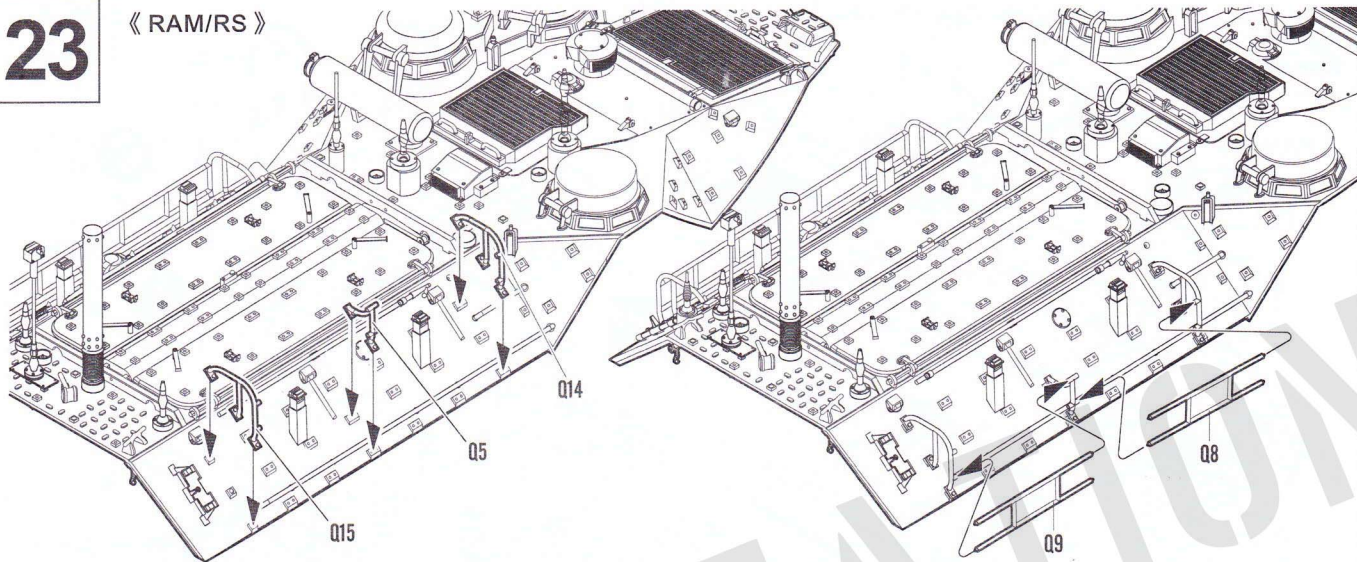

24

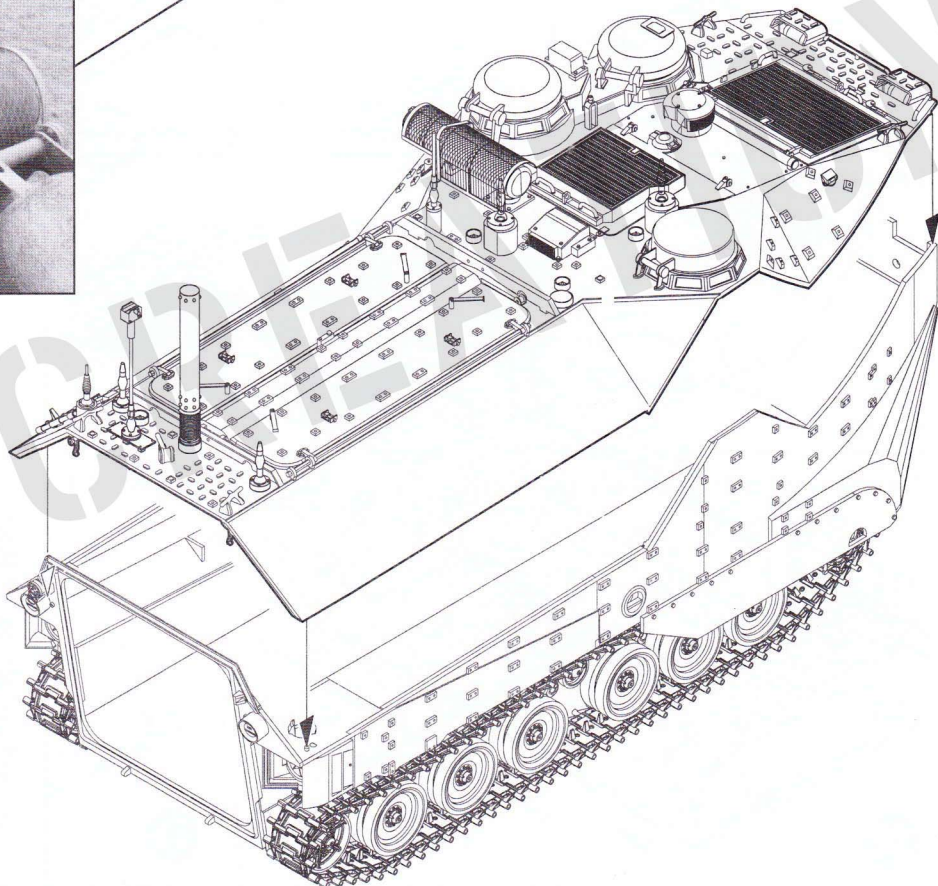
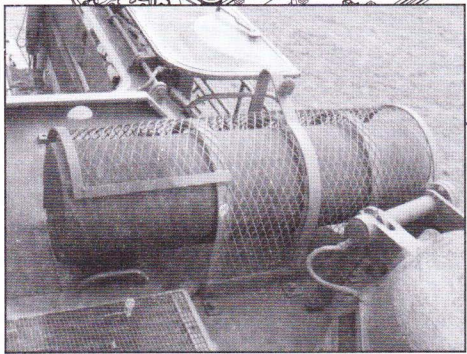
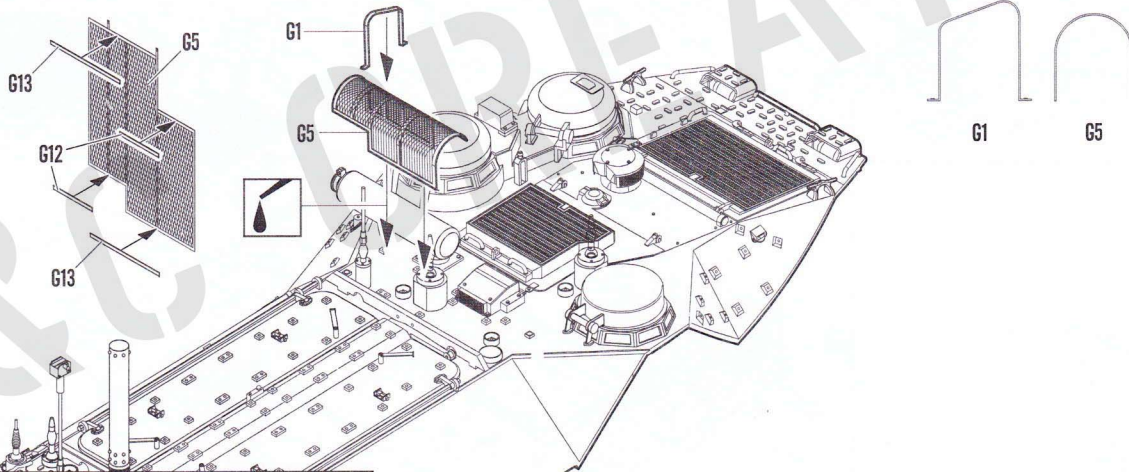

25

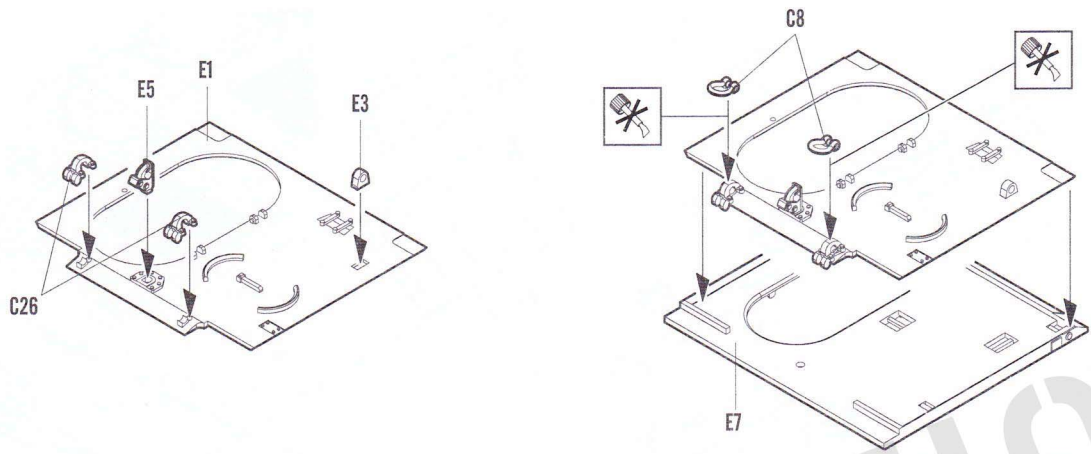

26

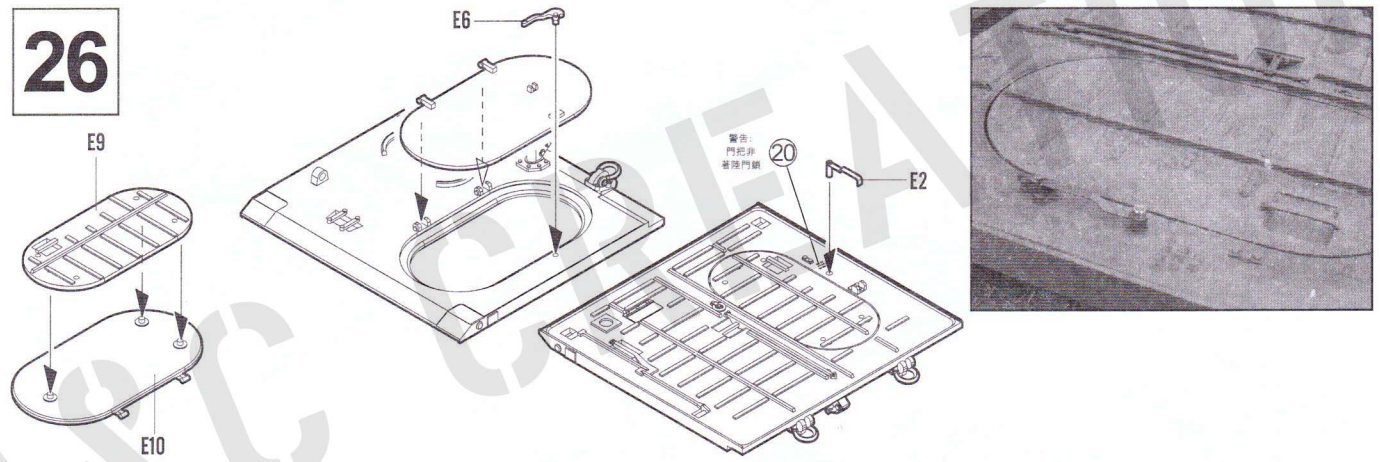

27

《 RAM/RS w/EAAC 》

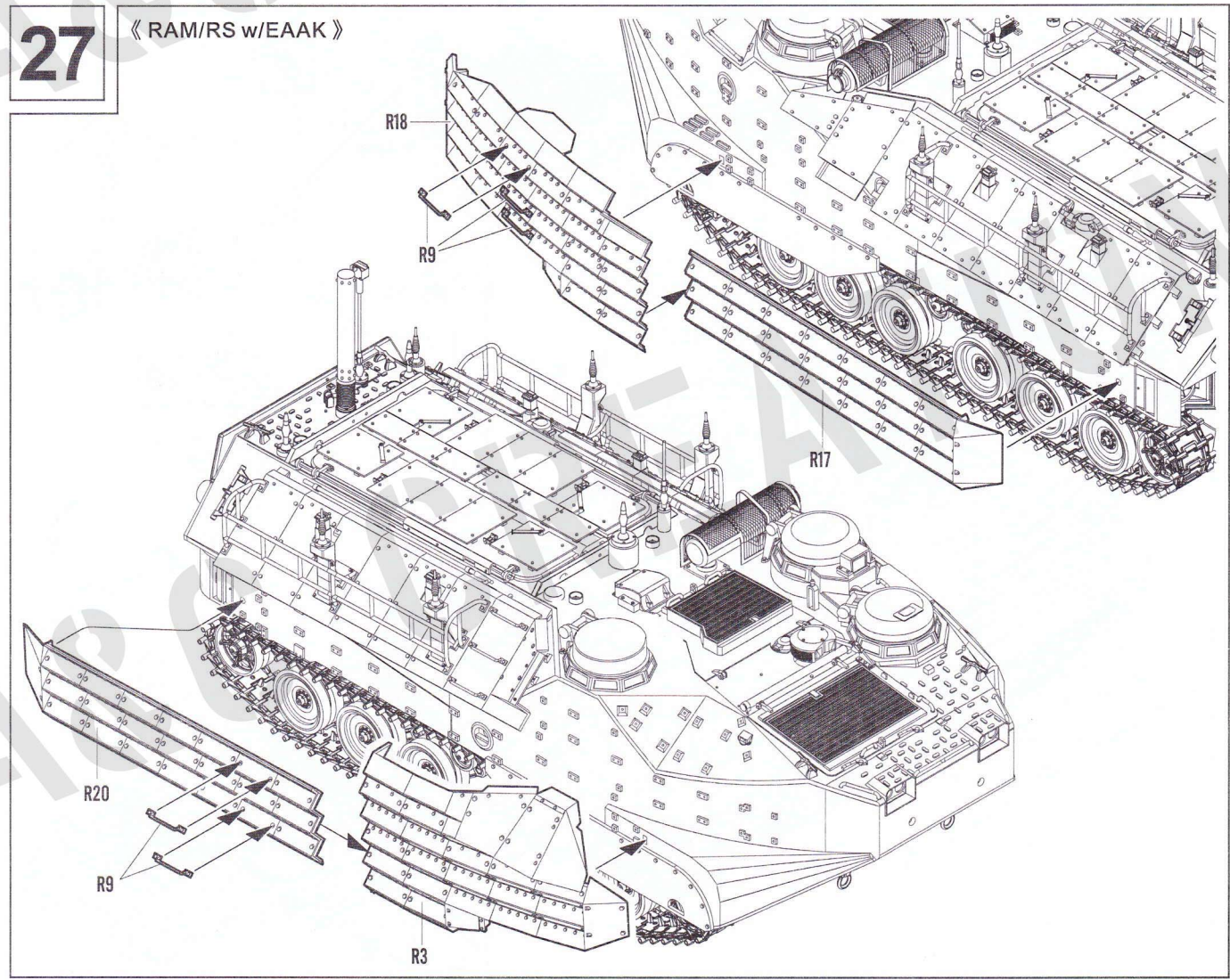

28

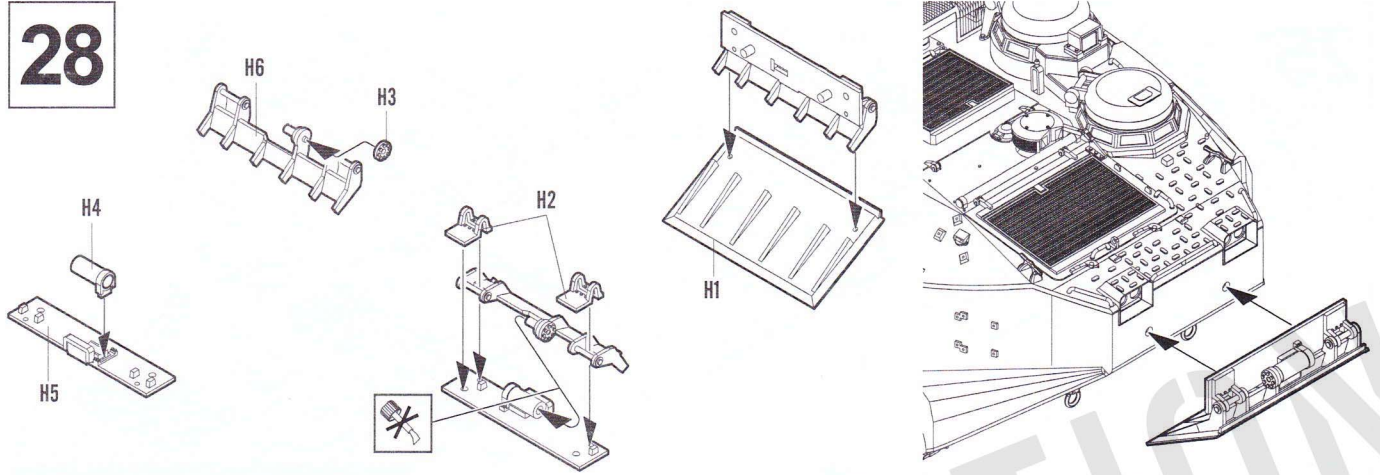

29

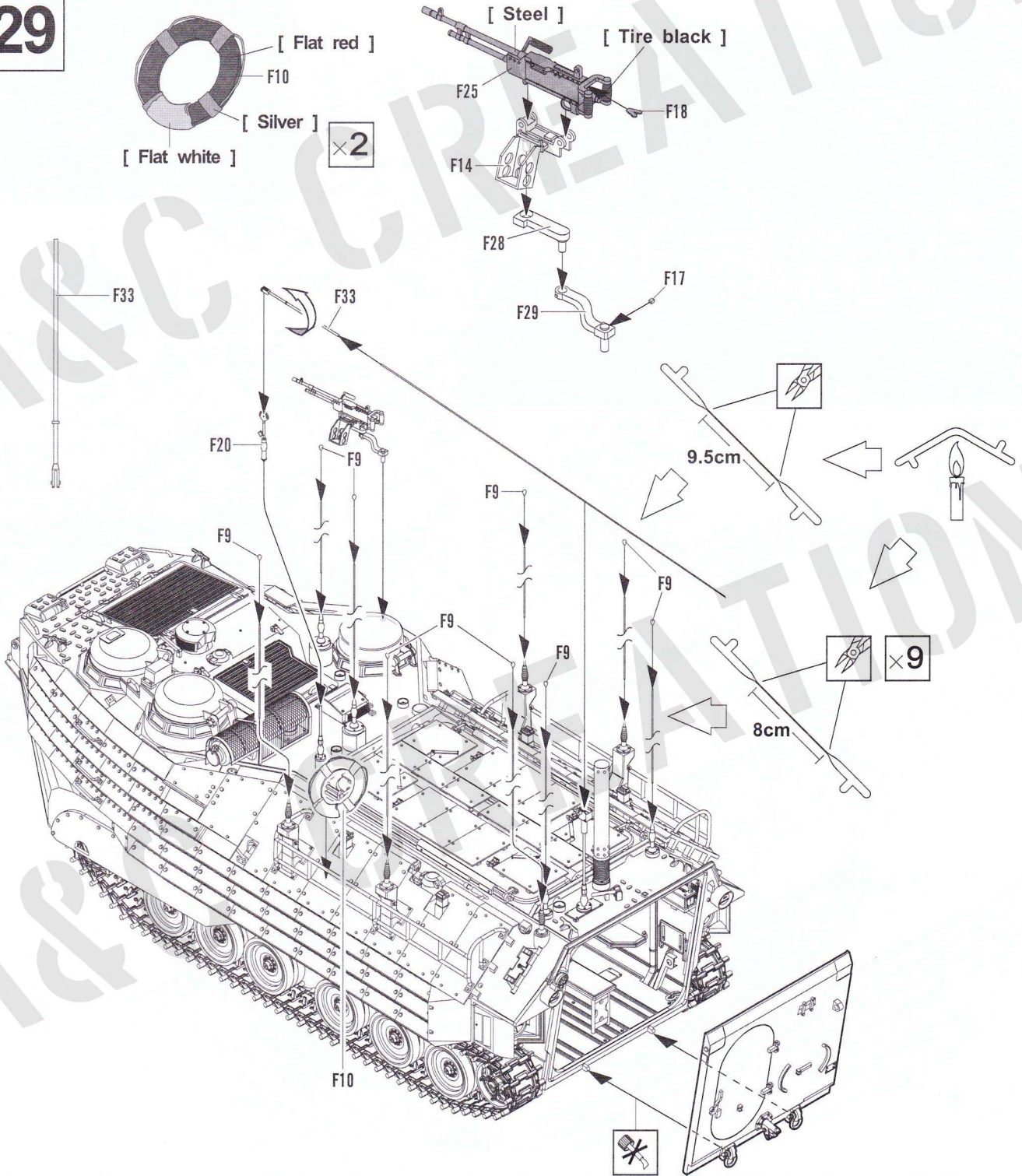

A U.S. Marines
美國海軍陸戰隊

 Body Color:

Bronze green 

Leather brown 

Tar black 

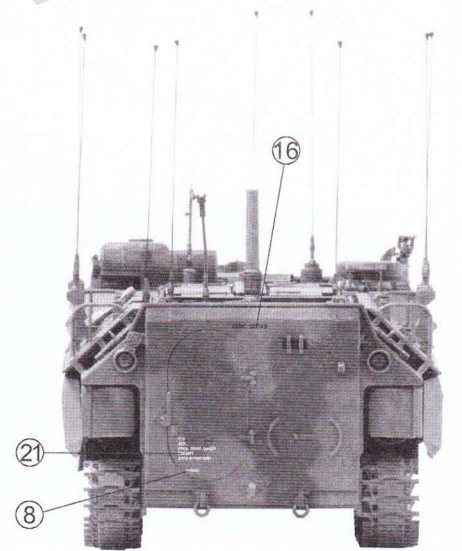
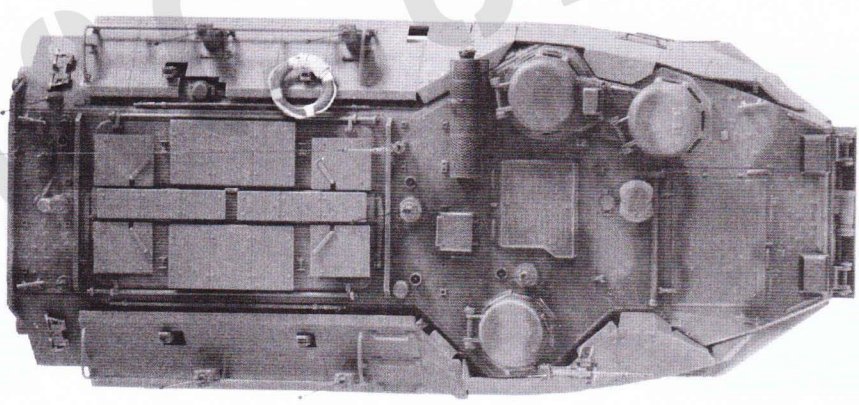
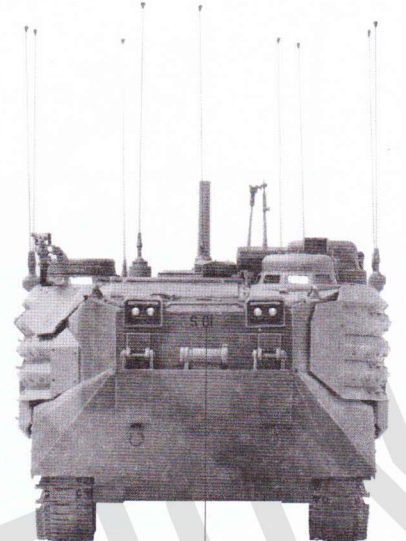
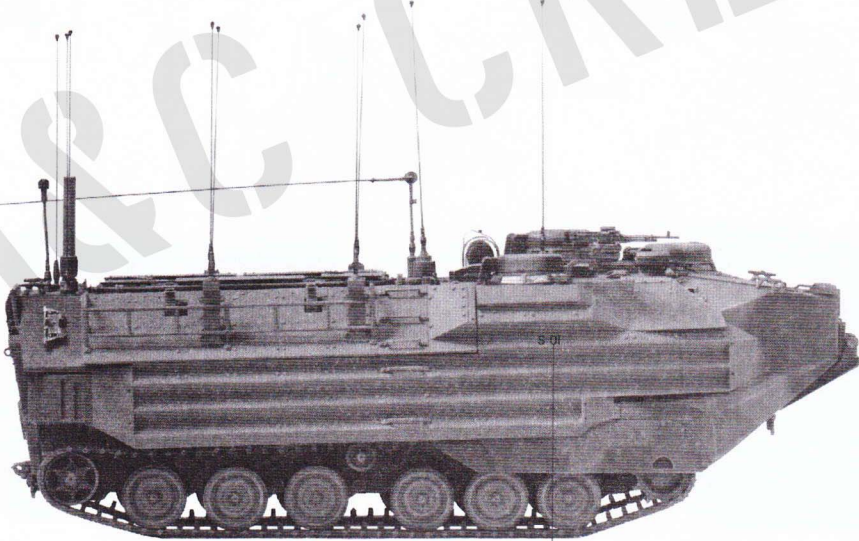
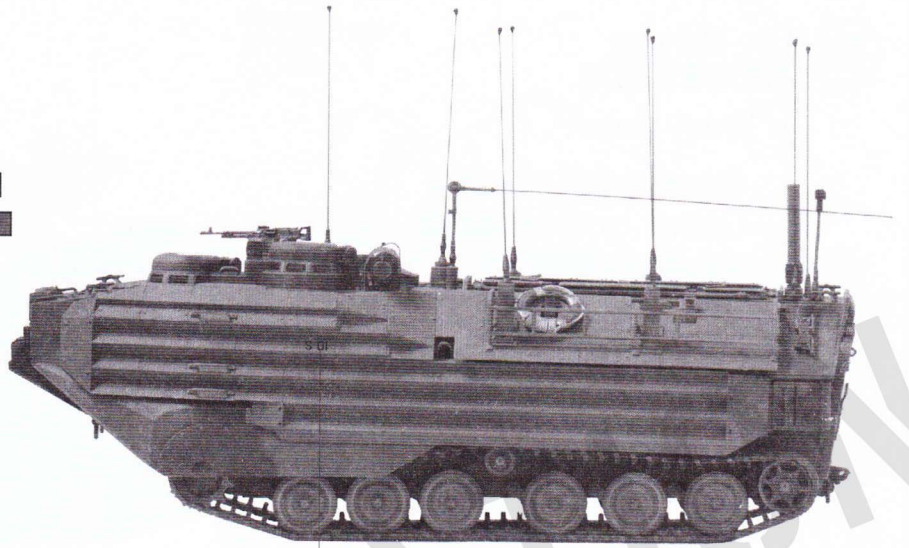

B U.S. Marines
美國海軍陸戰隊

 Body Color:

Bronze green 

Leather brown 

Tar black 

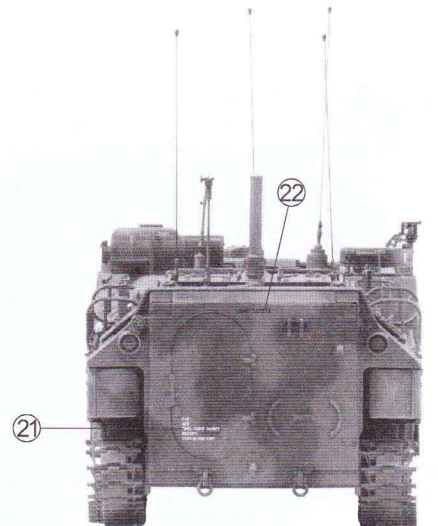
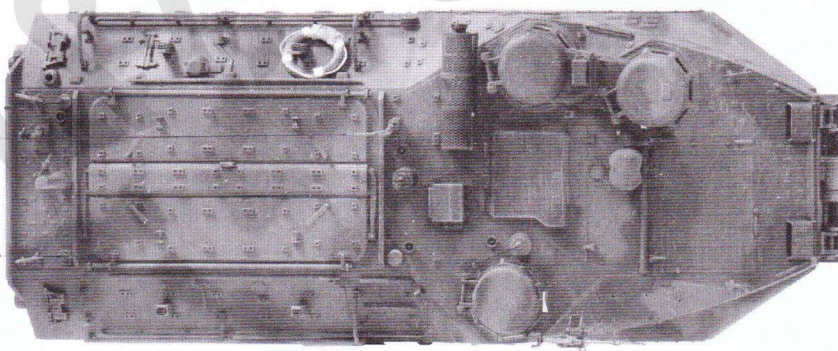
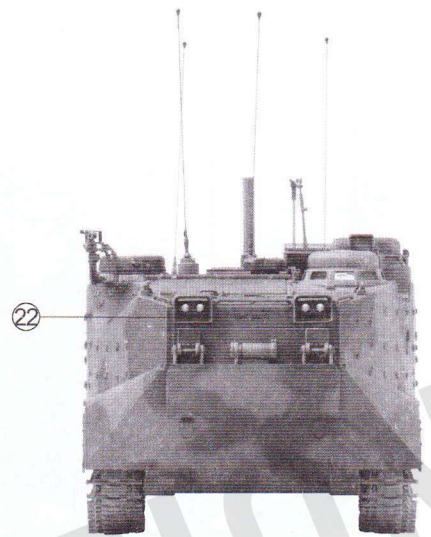
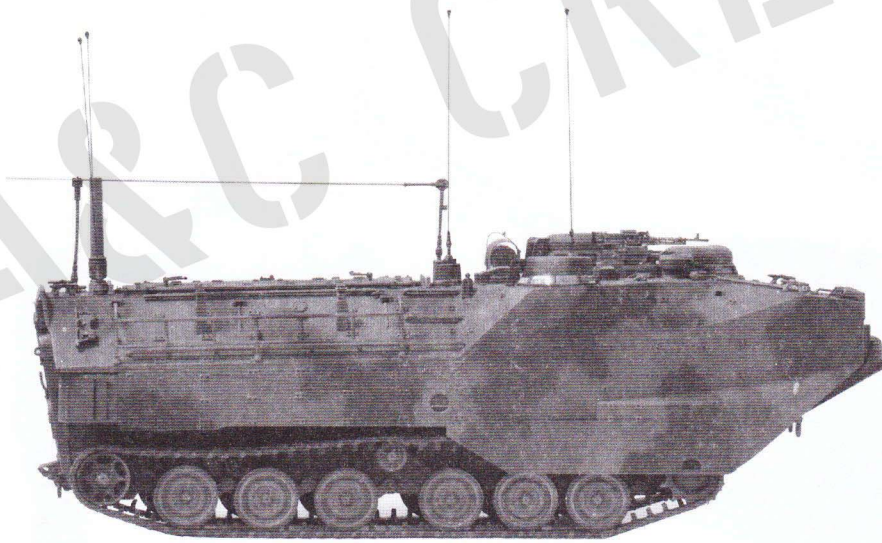
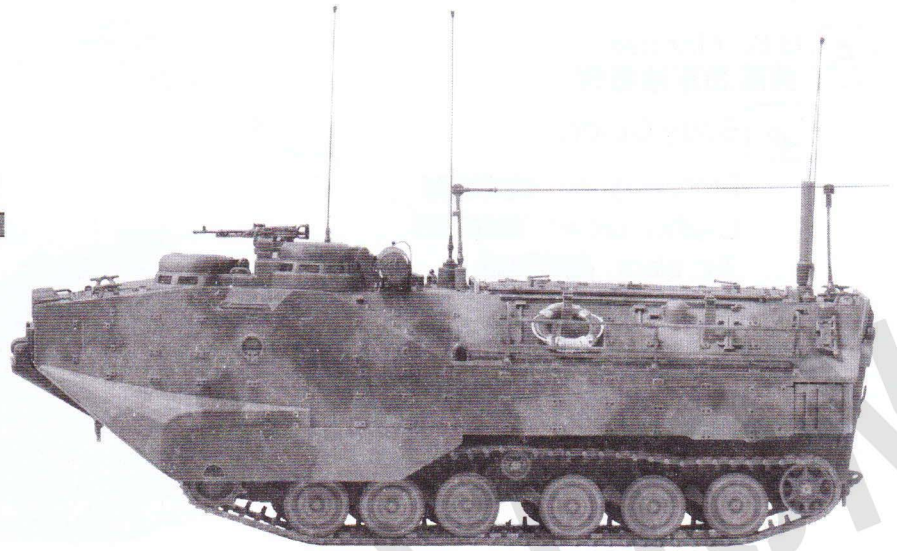

© R.O.C. Marine Corps
中華民國海軍陸戰隊

 Body Color:

Bronze green 

Leather brown 

Tar black 

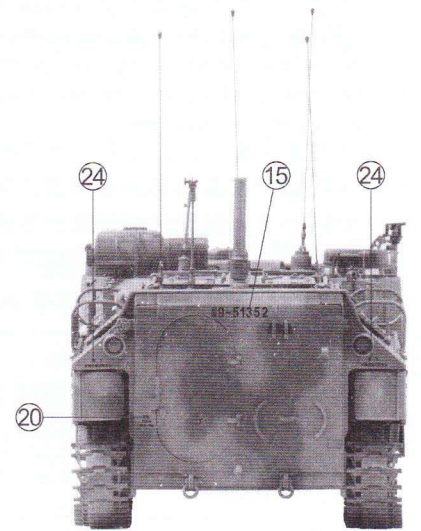
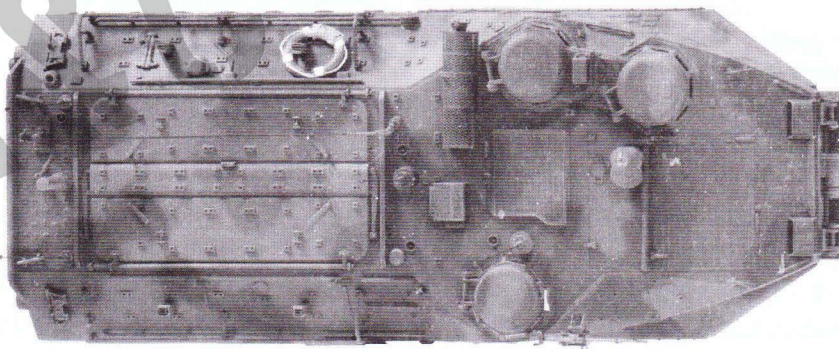
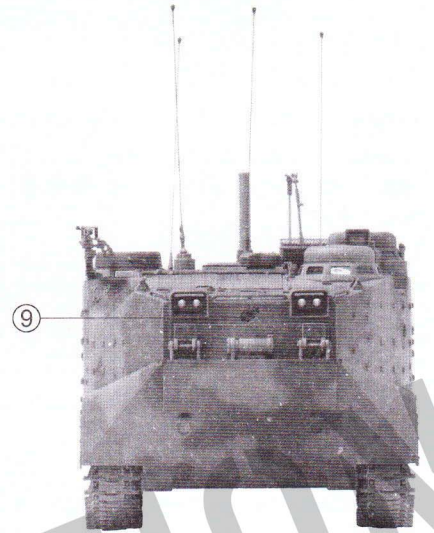
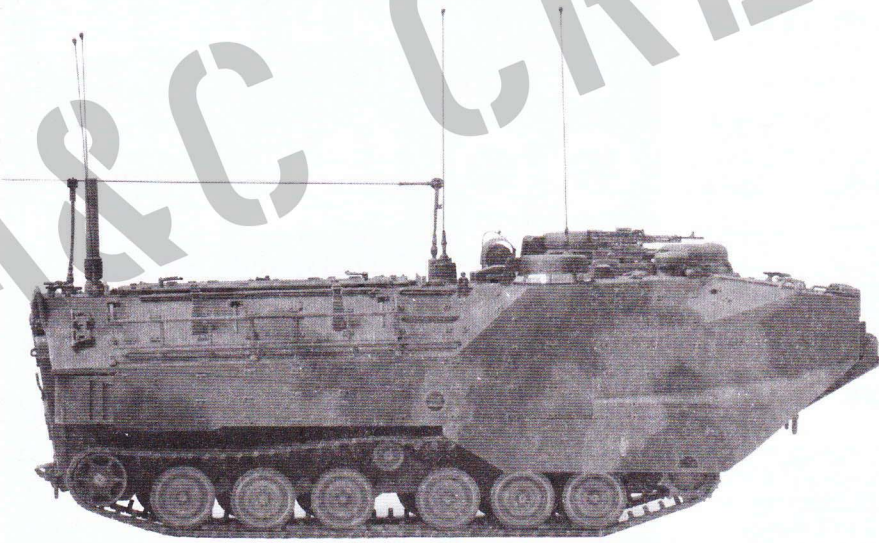
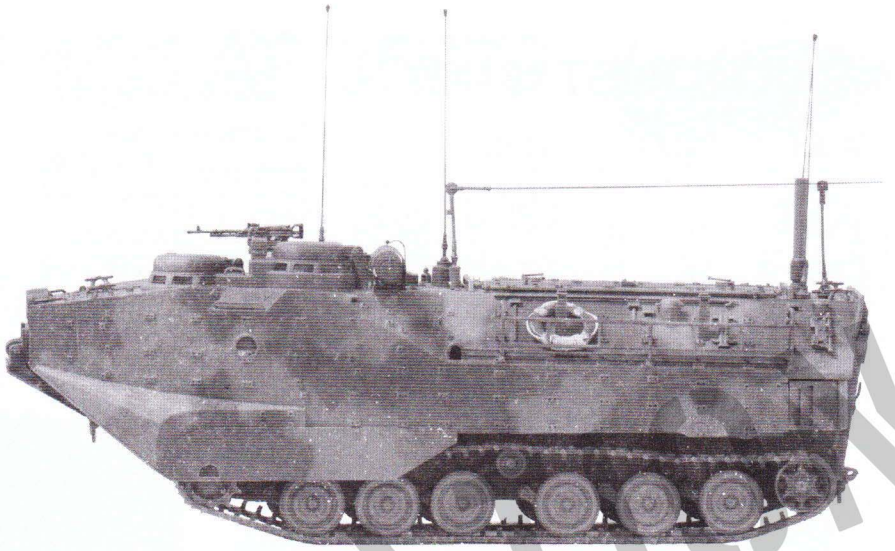

PARTS LIST 零件表

A X1

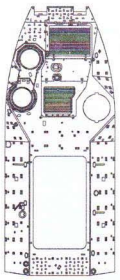

B X1

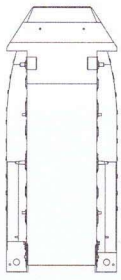

C X2

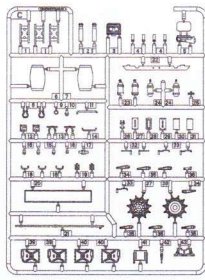

D X1

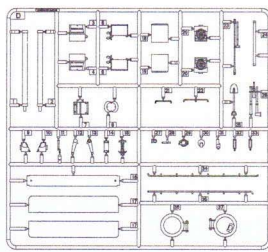

E X1

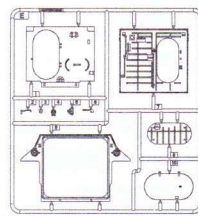

H X1

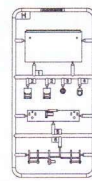

G X1

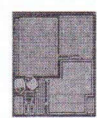

Z X1



Q X1

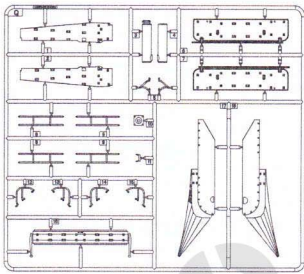

R X1

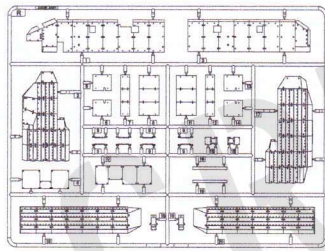

P X1

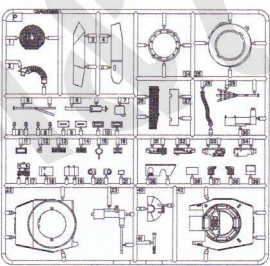

X X2

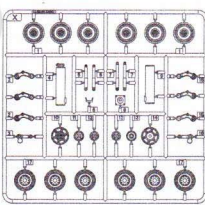

Y X1

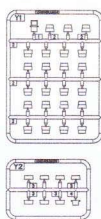

J X1



T X1

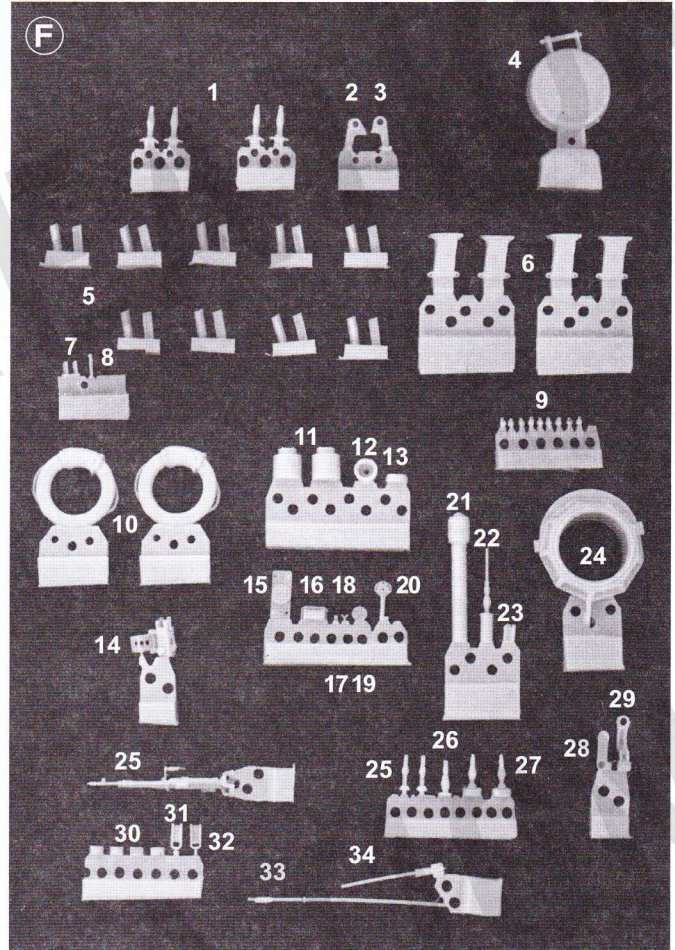
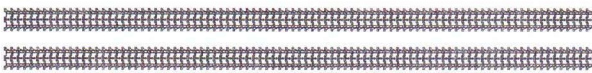

Instructions:

If for some reason, you are not fully satisfied or have questions concerning our product; Please use the form provide, and send it to our nearest representative or mail it directly to our office.

We will deal with that A.S.A.P.

AFV CLUB		
AF 35S70		
Parts Replacement Form		
<input type="checkbox"/> AF35S70-F	<input type="checkbox"/> AF35S70-J	<input type="checkbox"/> AF35S70-Z
<input type="checkbox"/> AF35S70-G	<input type="checkbox"/> AF35S70-T	
Reason for replacement:	<input type="checkbox"/> Missing	
	<input type="checkbox"/> Broken	
Signature: _____		

限臺灣地區使用 For Taiwanese use only!

總代理戰鷹企業 服務部收本公司將儘速為您處理。
請將本表與該部品相同金額之郵政匯票一同寄至

AFV CLUB		AF 35S70		申請人 姓名 地址 電話
零件補充申請表				
<input type="checkbox"/>	AF35S70-F	NT\$	750	
<input type="checkbox"/>	AF35S70-G	NT\$	200	
<input type="checkbox"/>	AF35S70-J	NT\$	160	
<input type="checkbox"/>	AF35S70-T	NT\$	280	
<input type="checkbox"/>	AF35S70-Z	NT\$	120	
		+郵寄費	NT\$ 80	
		(請填)總計NT\$ _____		
零件補充原因:(請於 <input type="checkbox"/> 打√)				
原包裝即 <input type="checkbox"/> 遺失或 <input type="checkbox"/> 毀損,				
製作途中 <input type="checkbox"/> 遺失或 <input type="checkbox"/> 毀損,				
其他原因 _____				