

## PLASTIC PARTS

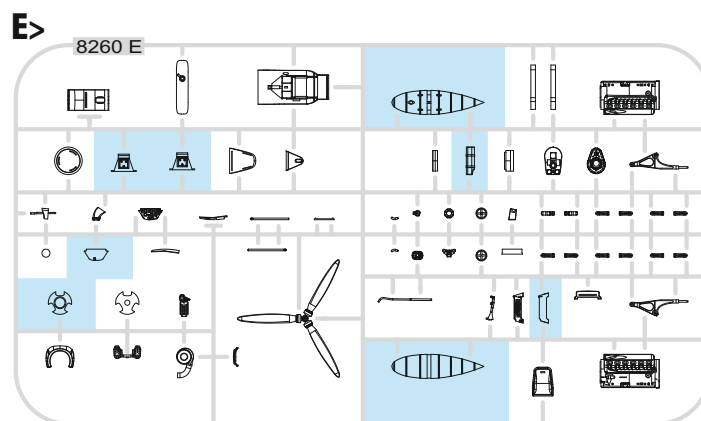
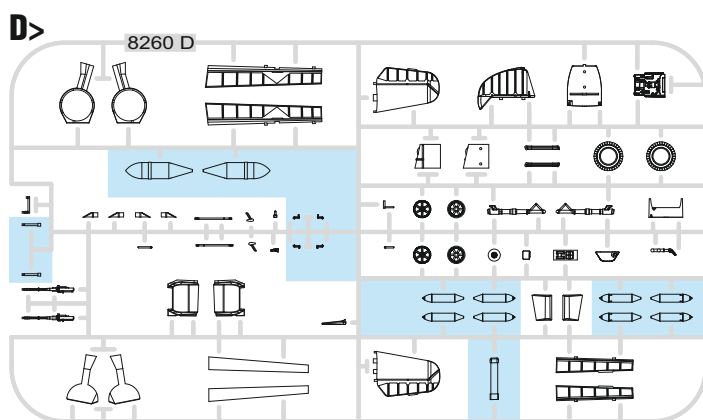
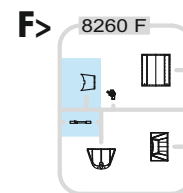
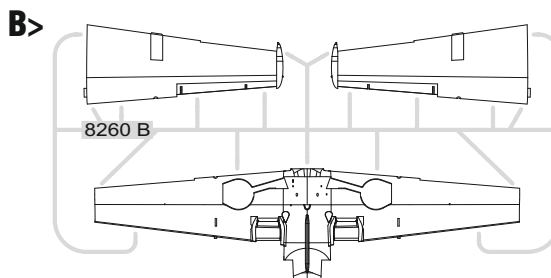
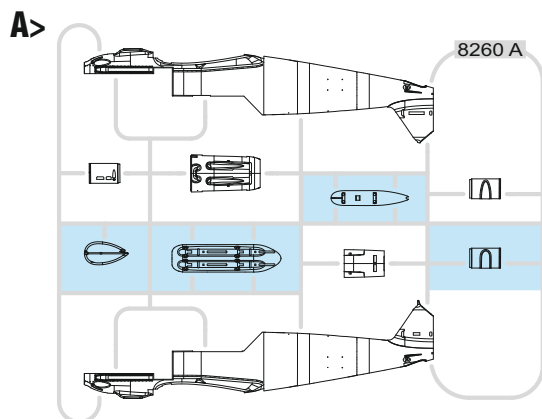

GSI Creos (GUNZE)		MISSION MODELS	
AQUEOUS	Mr.COLOR	PAINTS	
H2	C2	MMP-047	BLACK
H12	C33	MMP-047	FLAT BLACK
H47	C41	MMP-012	RED BROWN
H64	C17	MMP-087	RLM71 DARK GREEN
H65	C18	MMP-088	RLM70 BLACK GREEN
H67	C115	MMP-057	RLM65 LIGHT BLUE
H70	C60	MMP-056	RLM02 GRAY
H77	C137	MMP-040	TIRE BLACK
H90	C47		CLEAR RED

GSI Creos (GUNZE)		MISSION MODELS	
AQUEOUS	Mr.COLOR	PAINTS	
H94	C138		CLEAR GREEN
H414	C114	MMP-003	RLM23 RED
H416	C116	MMP-089	RLM66 BLACK GRAY
Mr.METAL COLOR		METALLICS	
MC214		MMM-001	DARK IRON
MC218		MMM-003	ALUMINIUM
Mr.COLOR SUPER METALLIC		METALLICS	
SM201		MMC-001	SUPER FINE SILVER

## ATTENTION \* UPOZORNĚNÍ \* ACHTUNG \* ATTENTION

- (GB)** Carefully read instruction sheet before assembling. When you use glue or paint, do not use near open flame and use in well ventilated room. Keep out of reach of small children. Children must not be allowed to suck any part, or pull vinyl bag over the head.
- (CZ)** Před započatím stavby si pečlivě prostudujte stavební návod. Při používání barev a lepidel pracujte v dobře větrané místnosti. Lepidla ani barvy nepoužívejte v blízkosti otevřeného ohně. Model není určen malým dětem, mohlo by dojít k požití drobných dílů.
- (D)** Vor dem Zusammenbau die Bauanleitung gut durchlesen. Kleber und Farben nicht in der Nähe von offenem Feuer verwenden und für eine ausreichende Belüftung sorgen. Den Bausatz von kleinen Kindern fernhalten. Vermeiden Sie, dass Kinder Bauteile in den Mund nehmen oder sich Plastiktüten über den Kopf ziehen.
- (F)** Lire soigneusement la fiche d'instructions avant d'assembler. Ne pas utiliser de colle ou de peinture à proximité d'une flamme nue, et aérer la pièce de temps en temps. Garder hors de portée des enfants en bas âge. Ne pas laisser les enfants mettre en bouche ou sucer les pièces, ou passer un sachet vinyl sur la tête.

## INSTRUCTION SIGNS \* INSTR. SYMBOLS \* INSTRUKTION SINNBILDEN \* SYMBOLES

- (?)** OPTIONAL VOLBA
- (↑)** BEND OHNOUT
- (/)** SAND BROUSIT
- (○)** OPEN HOLE VYVRTAT OTVOR
- (↔)** SYMETRICAL ASSEMBLY SYMETRICKÁ MONTÁŽ
- (✂)** REMOVE ODŘÍZNOUT
- (↺)** REVERSE SIDE OTOČIT
- (★)** APPLY EDUARD MASK AND PAINT POUŽIT EDUARD MASK NABARVIT

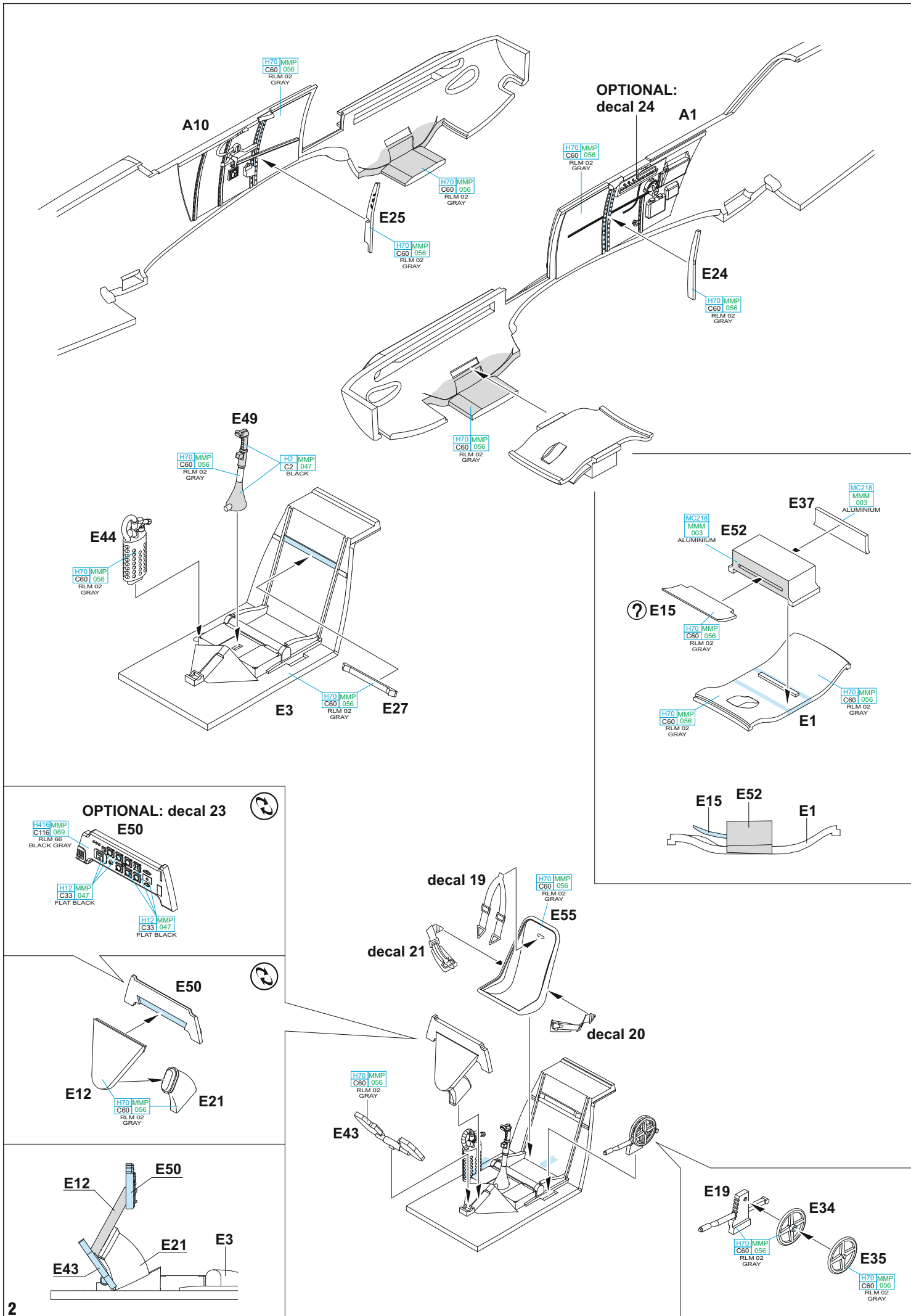

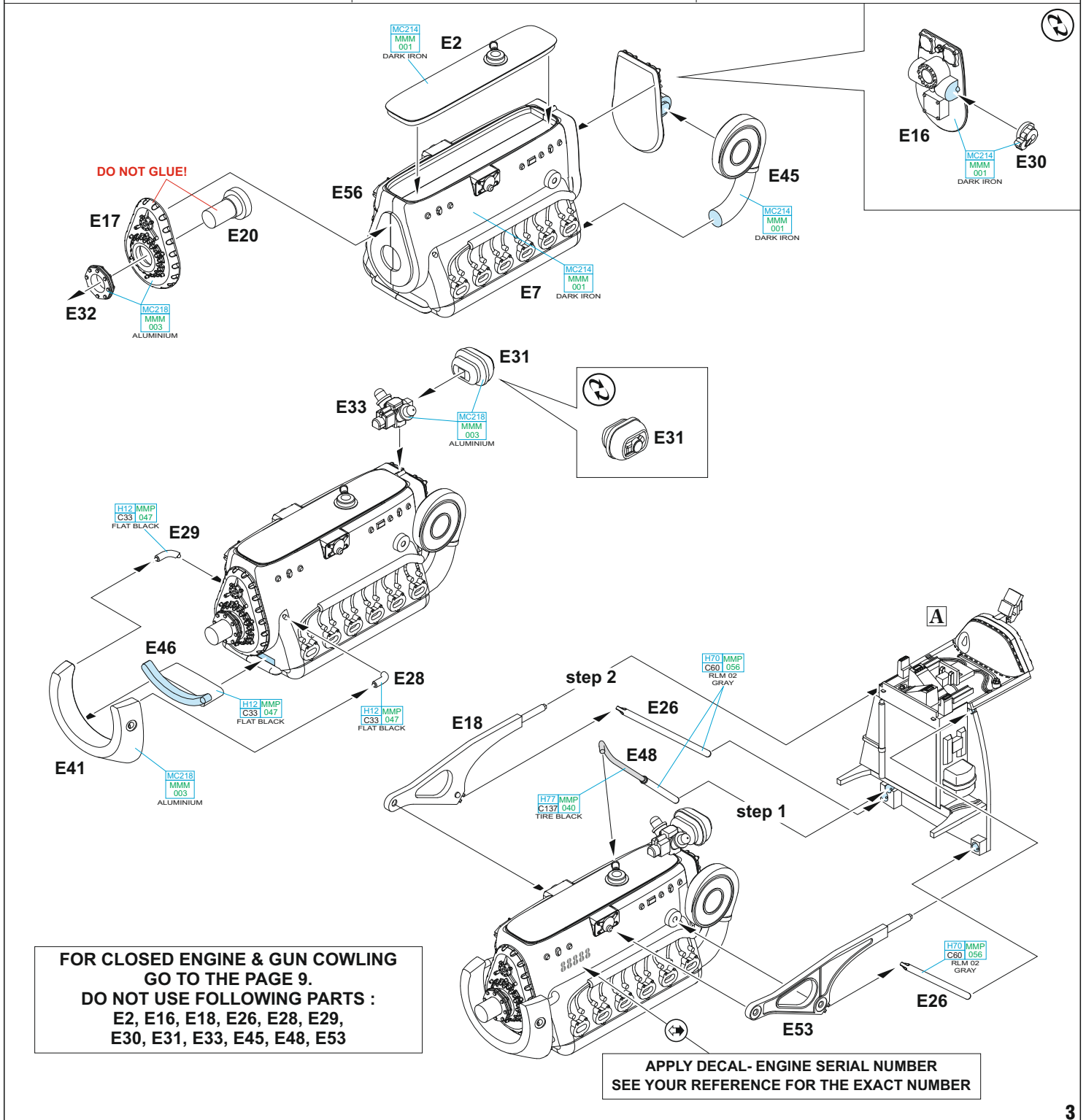
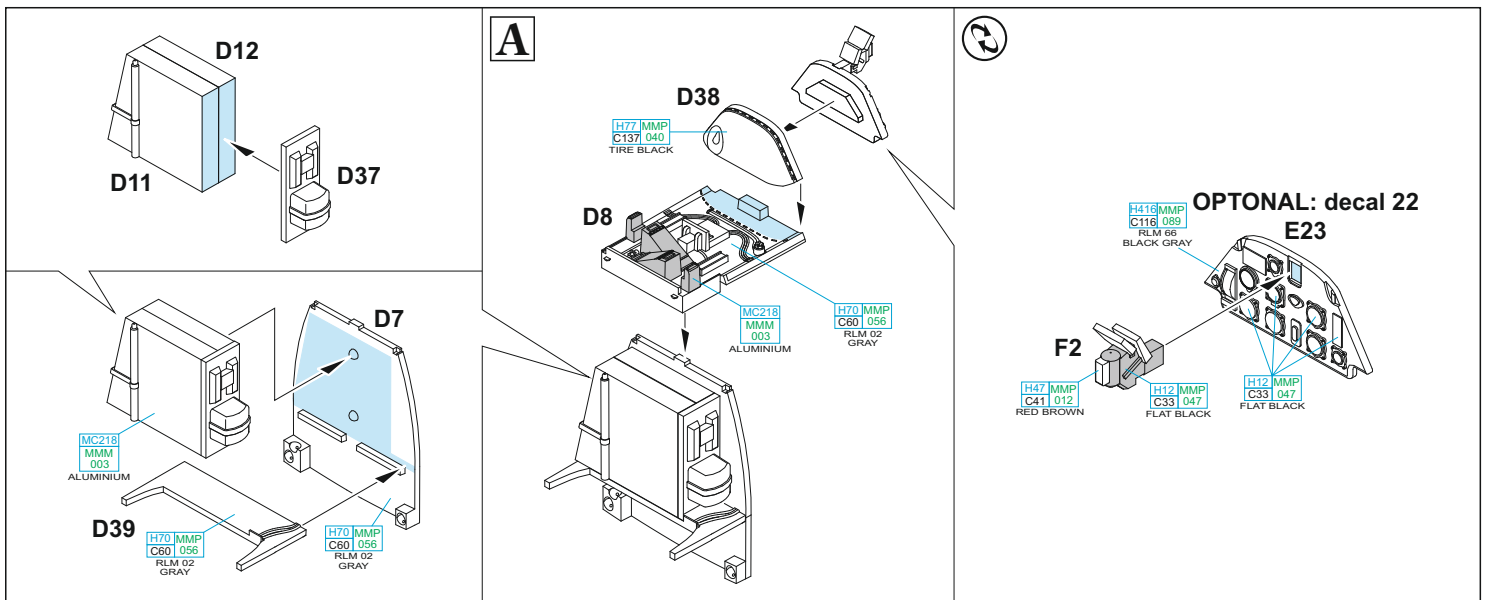

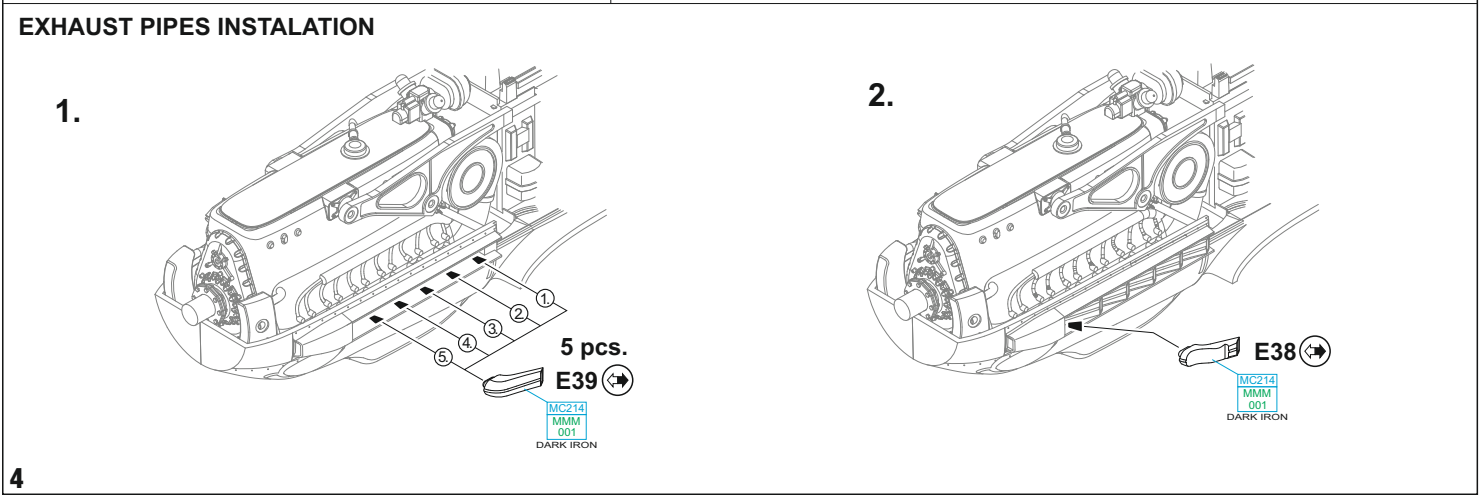
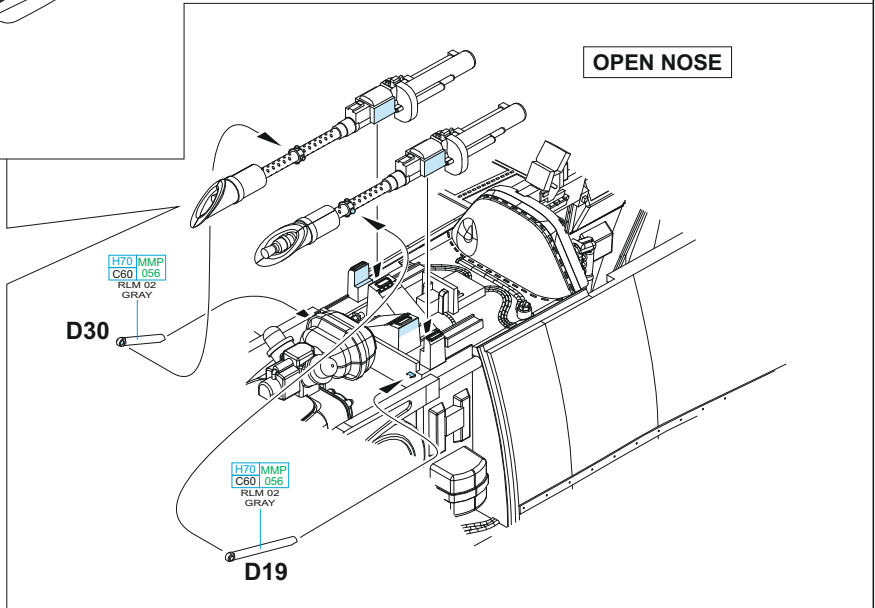
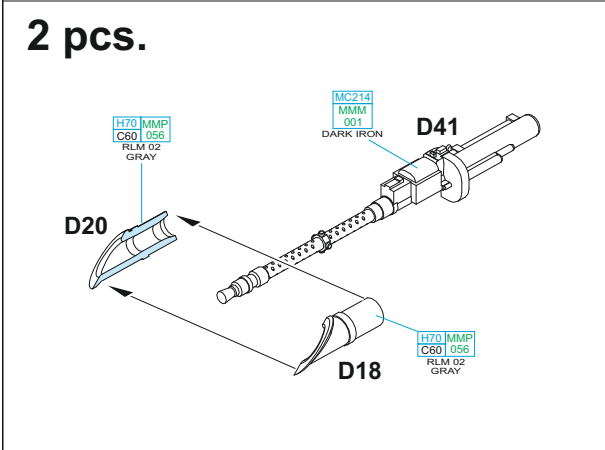
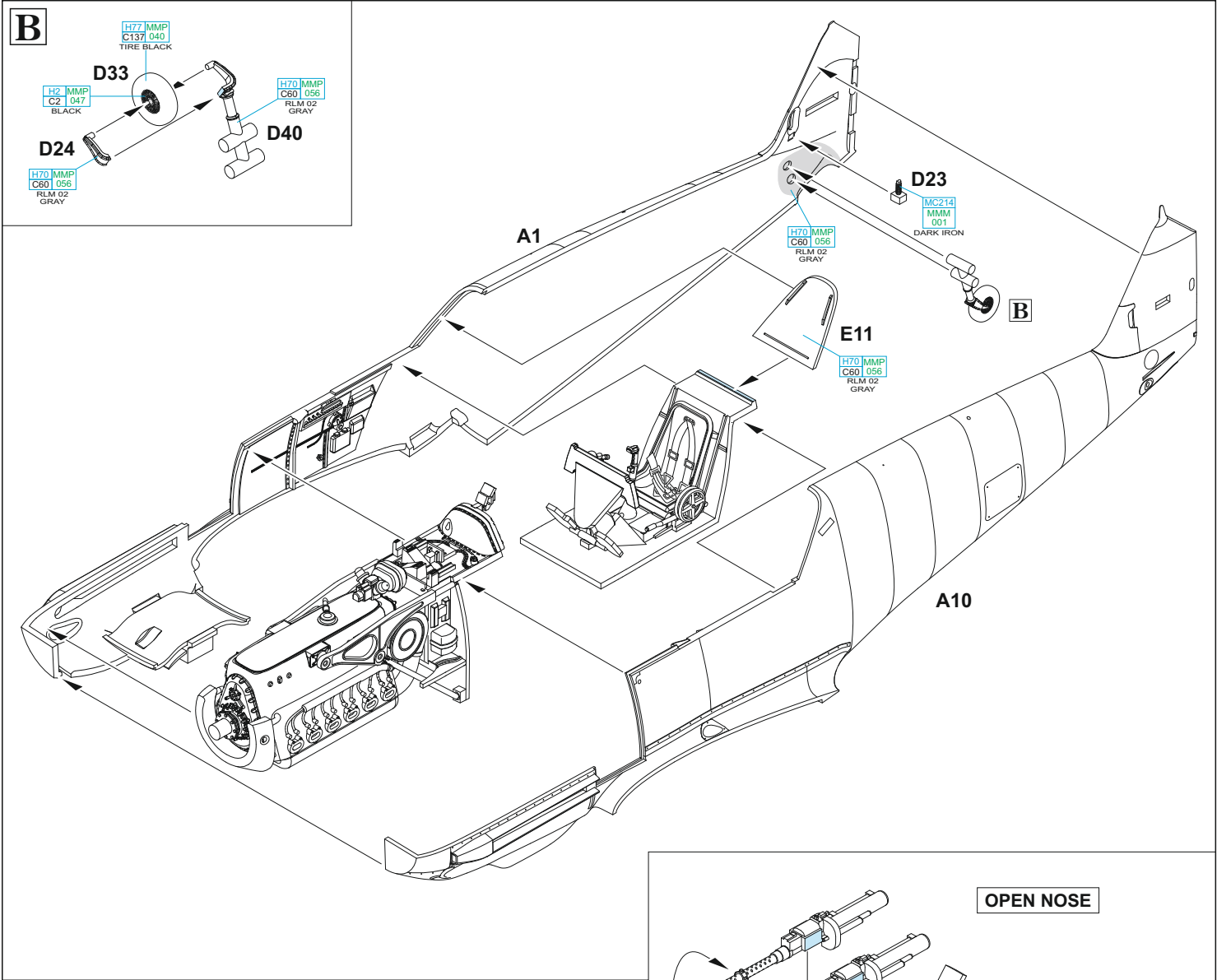

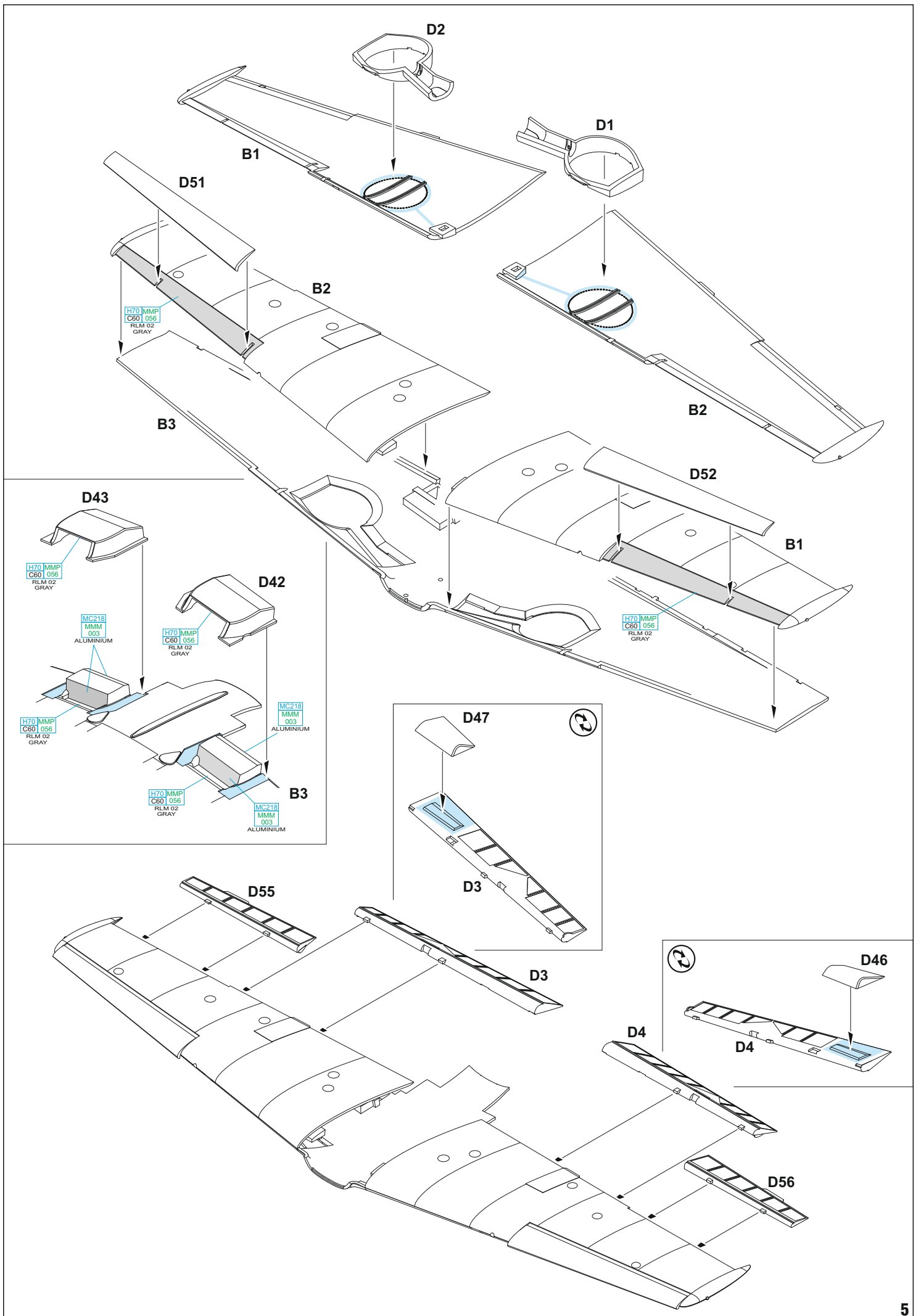



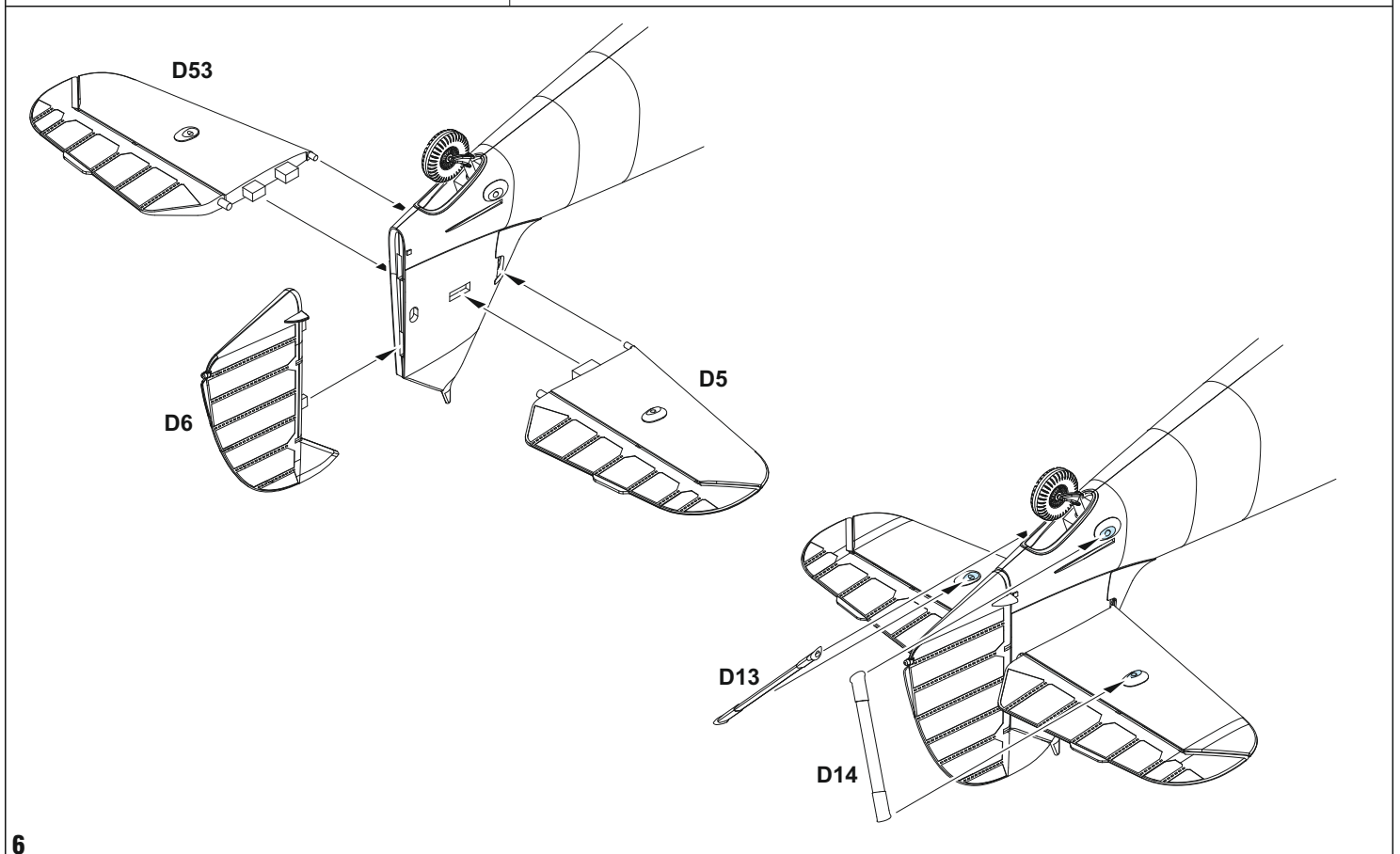
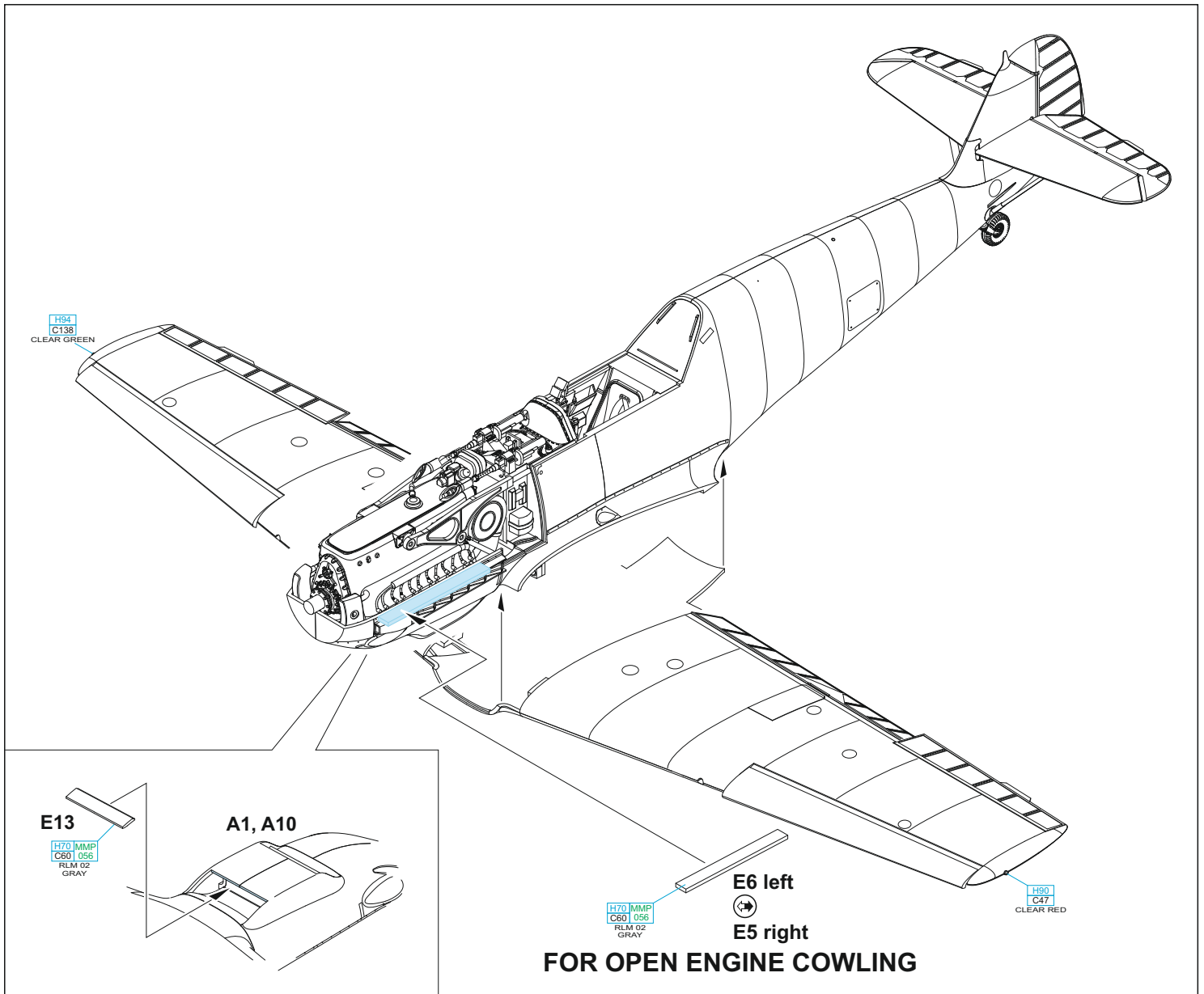

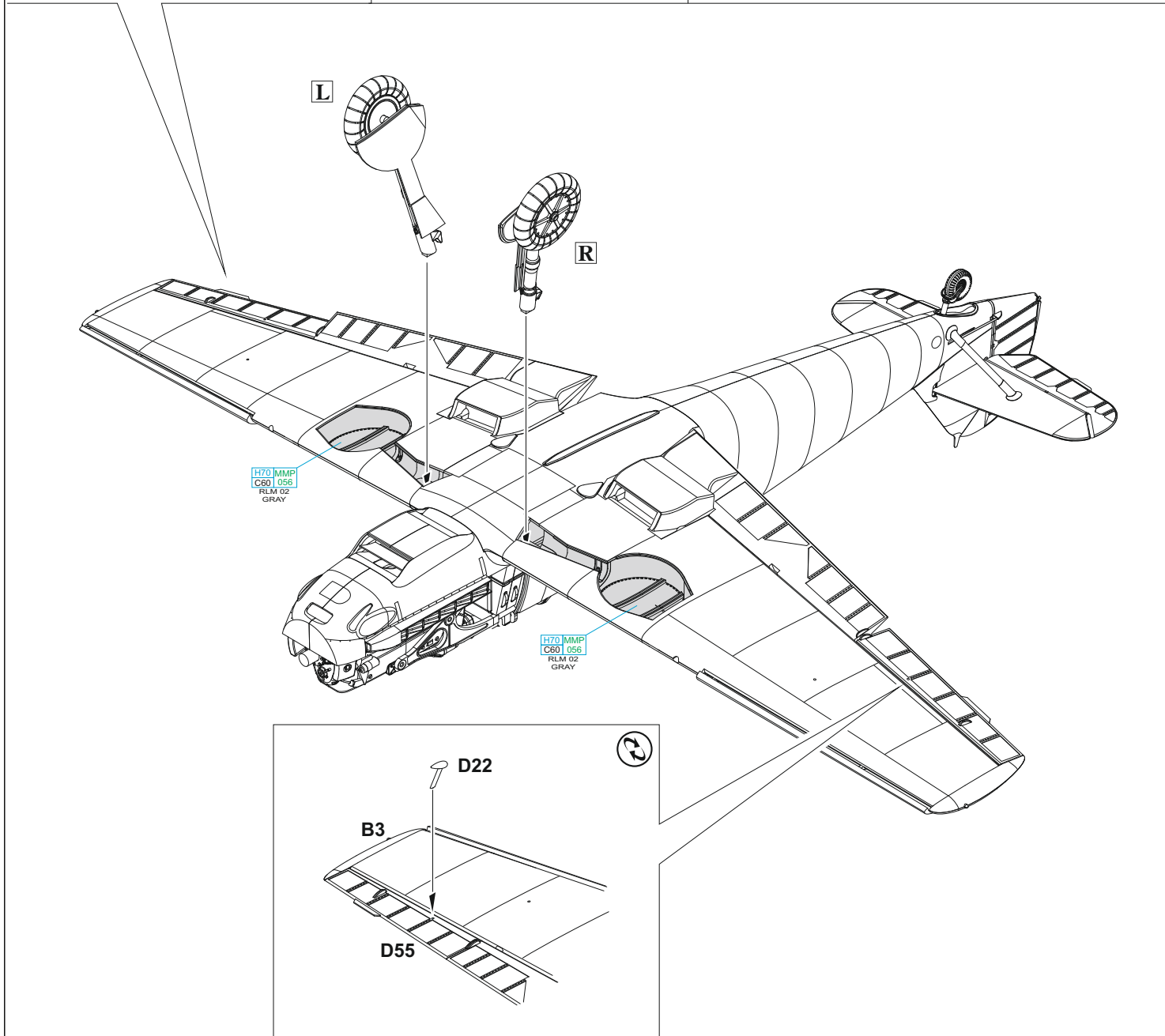
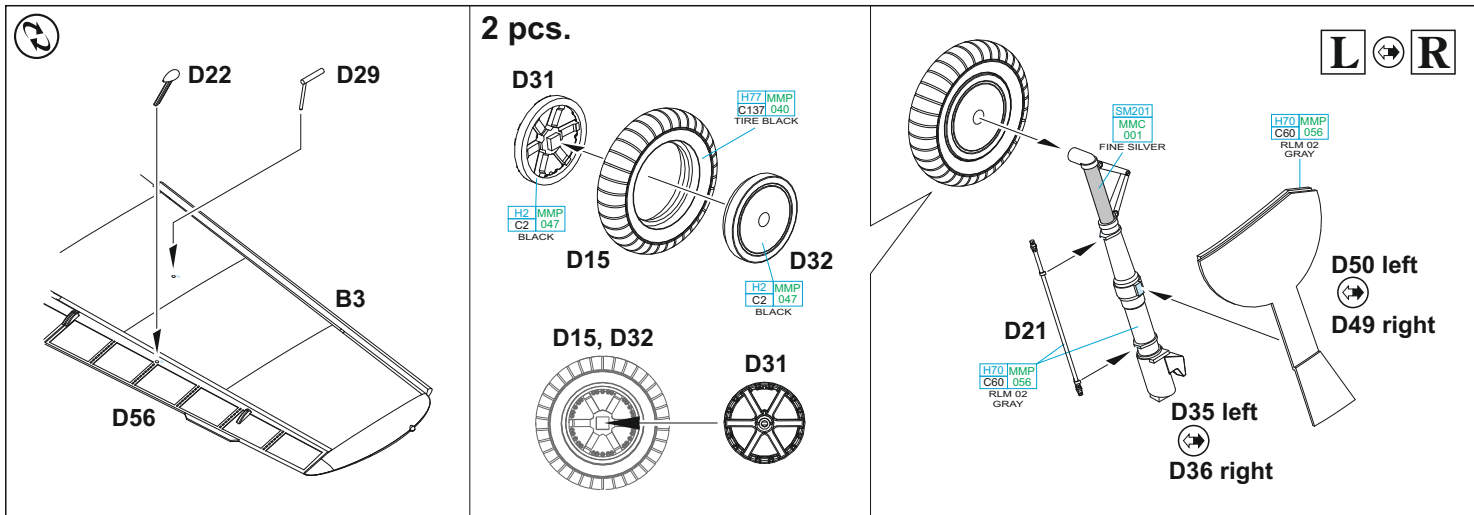

**THE CORRECT POSITION OF THE UNDERCARRIAGE LEGS**

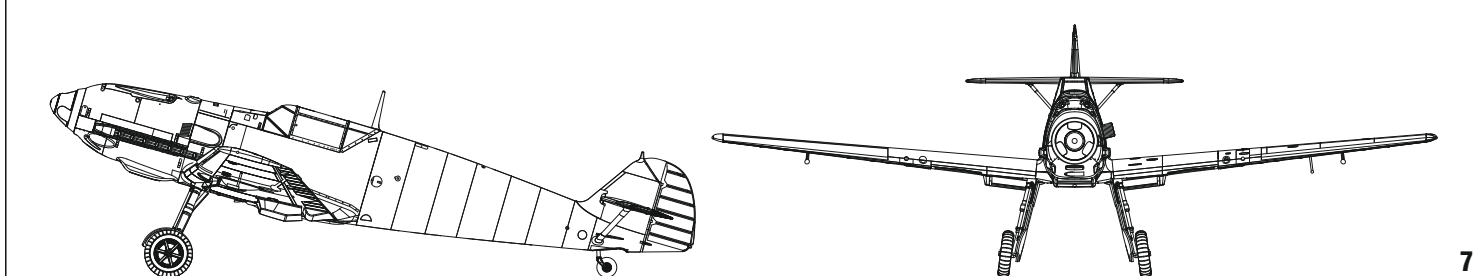

**C**

**FOR CLOSED NOSE  
SEE PAGE 9**

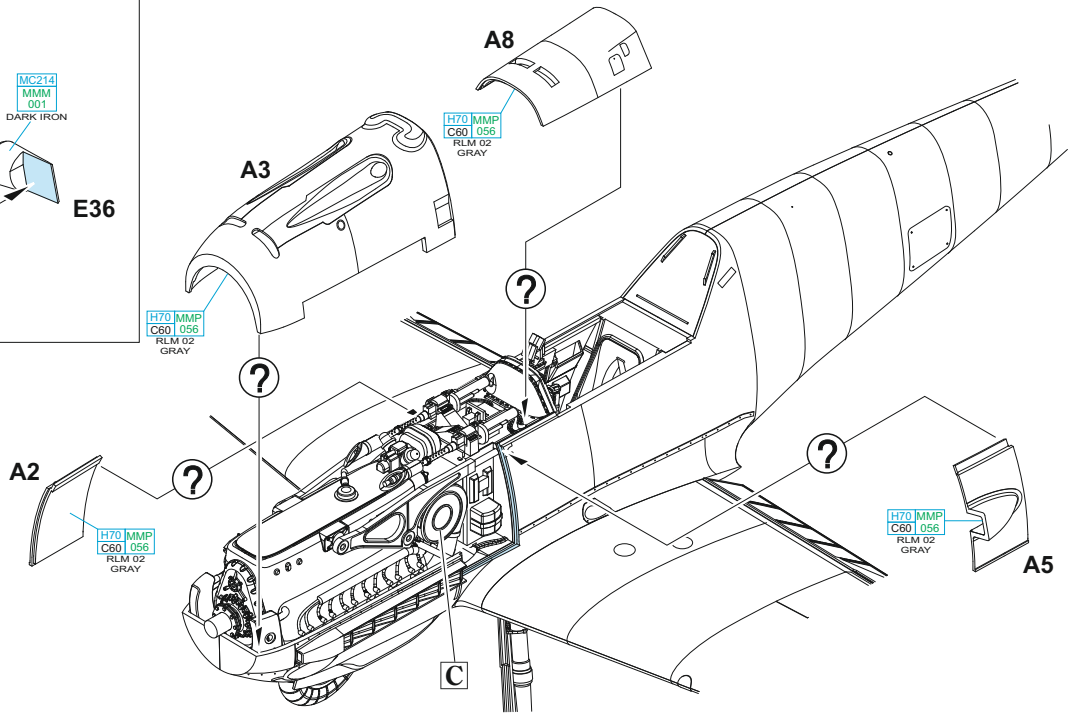
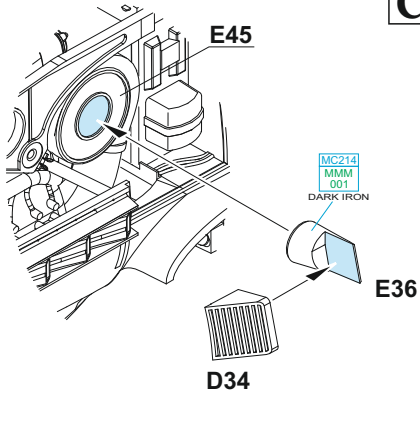

**OPEN CANOPY  
F3**

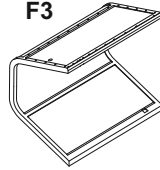

**CLOSED CANOPY  
F3**

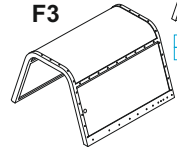

**D44**

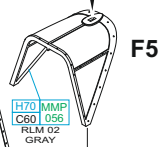

**F6**

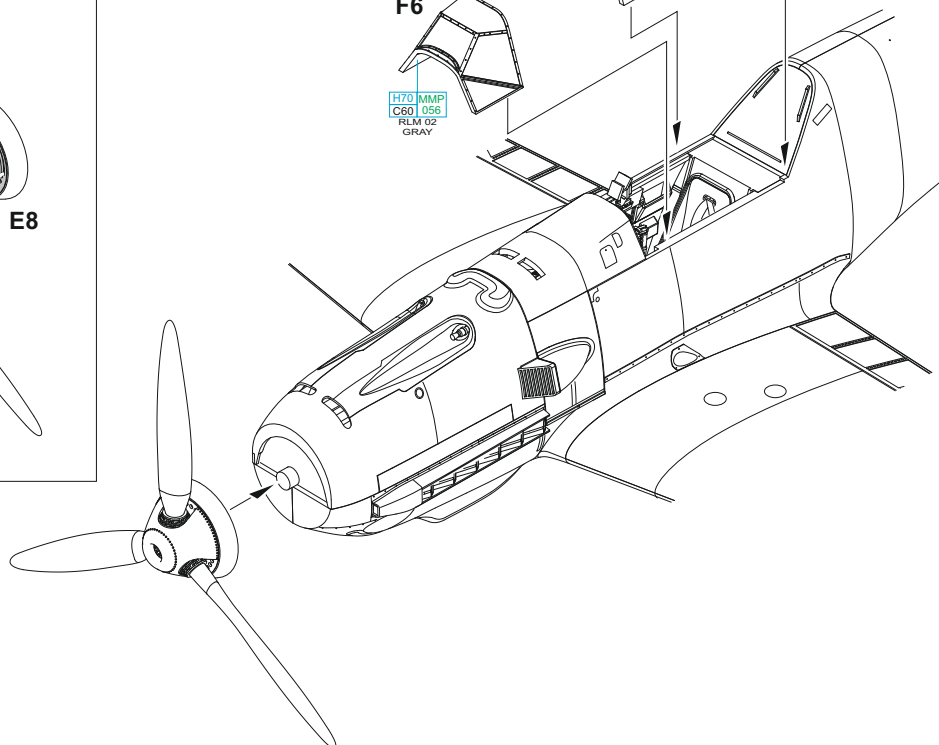
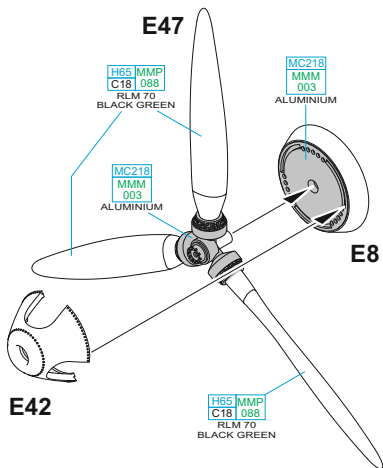



**FOR CLOSED ENGINE COMPARTMENT ONLY**

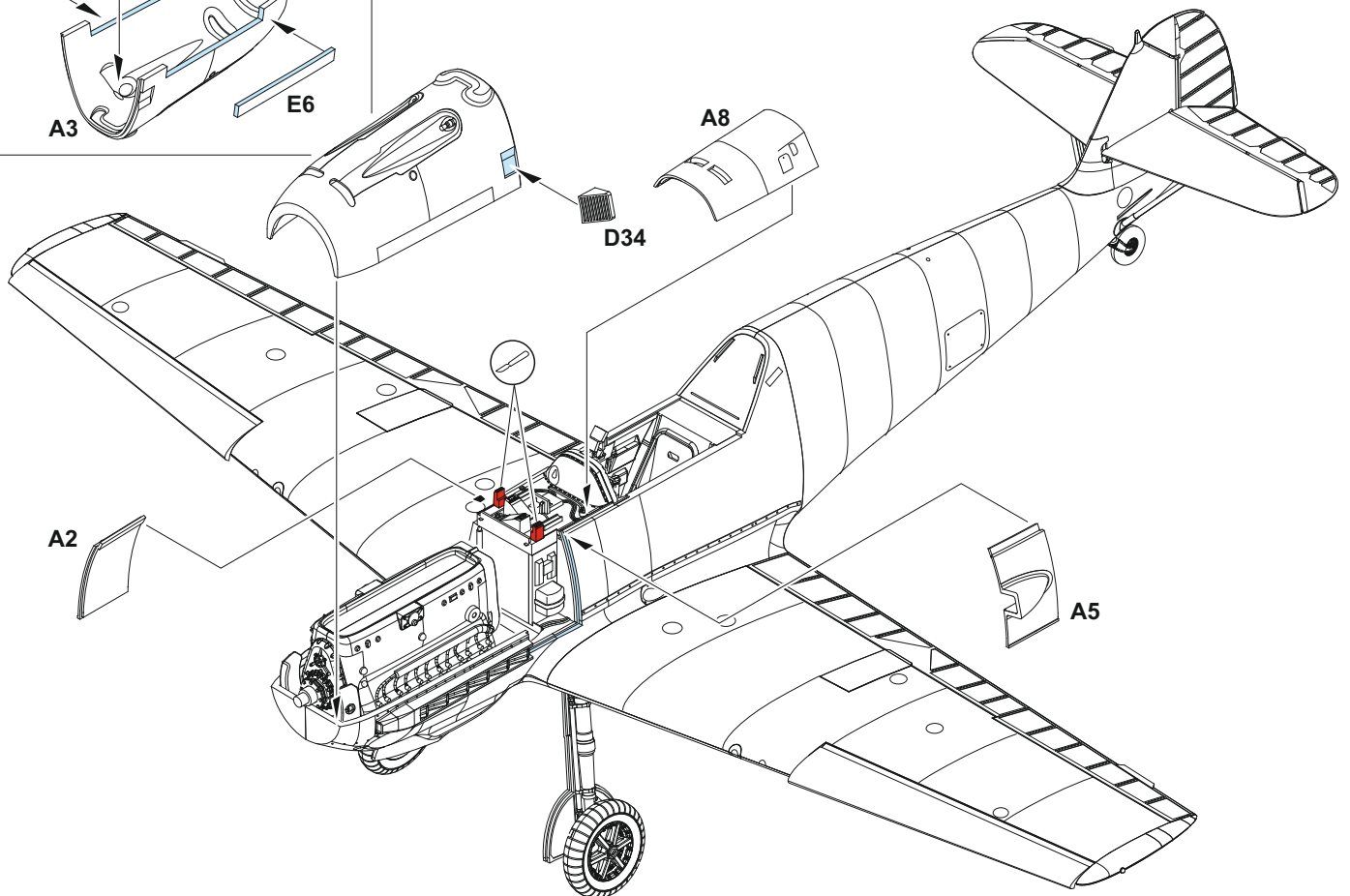
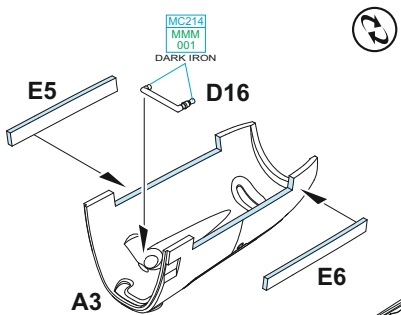
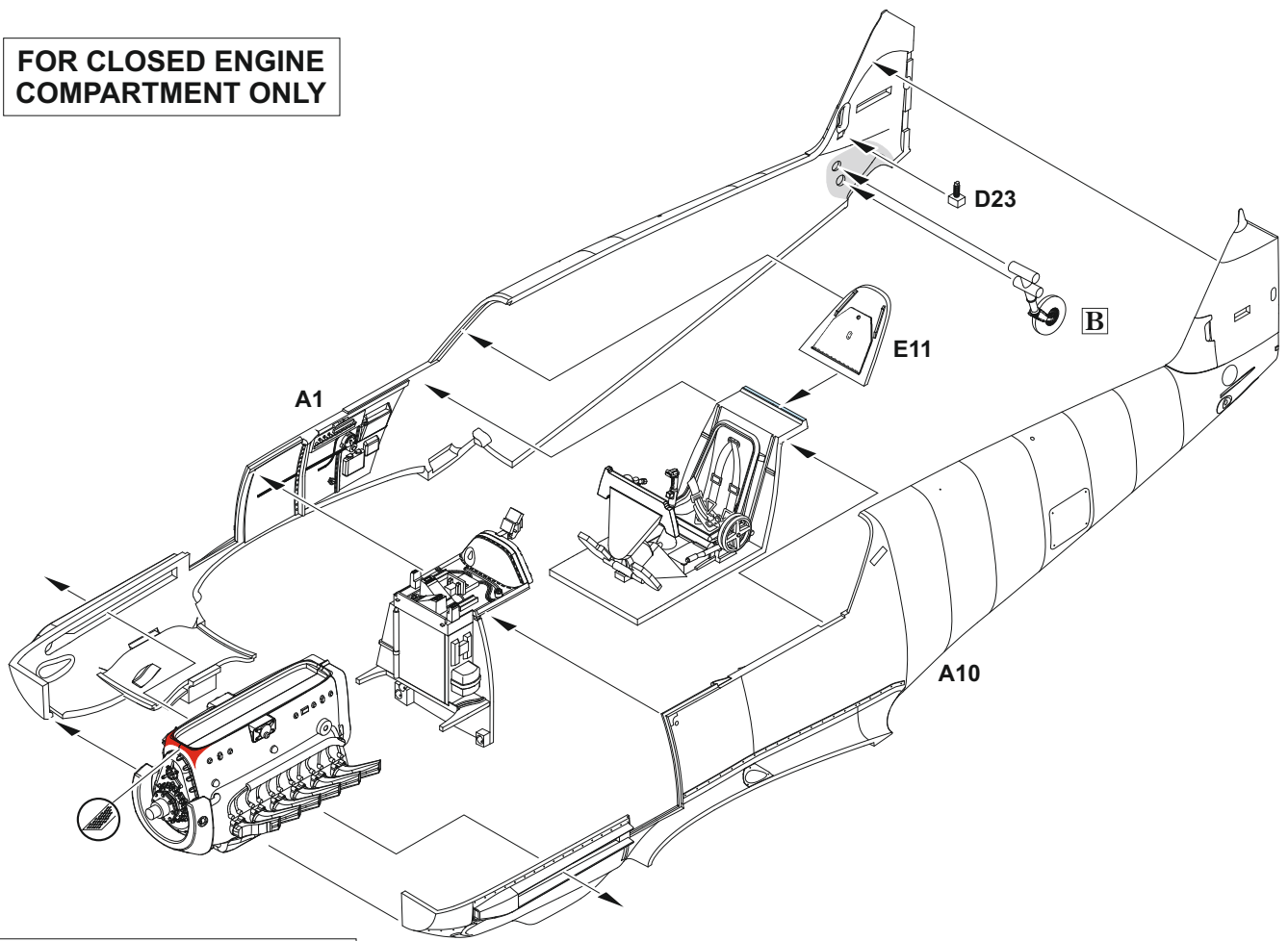

# A W.Nr. 3250, flown by Hptm. Johannes Janke, CO of I./JG 77, Juliusburg, Germany, August 1939

In June 1938 Capt. Johannes Janke assumed the command of IV. Gruppe JG 132, equipped with Bf 109D aircraft, succeeding the WWI ace Obstlt. Theo Osterkamp. At that time the unit was based at Werneuchen airfield and before the attack on Poland on September 1st, 1939 the Gruppe personnel moved five times to different airfields and even the unit was re-designed twice, first to I./JG 331 (on November 1st, 1938) and second to I./JG 77 (on May 1st, 1939). No wonder that this unit was nicknamed Wanderzirkus Janke (Janke's Traveling Circus). In May 1939 Bf 109E aircraft were added to its inventory. Janke commanded I./JG 77 until August 25th, 1940 when he was given command of IV./JG 51. At that time Bf 109E-1 fighters were camouflaged in RLM 70/71 on the upper and side surfaces sprayed in the prescribed splinter pattern. The lower surfaces were coated in RLM 65. The unit's marking can be found on the both sides of the aircraft nose.

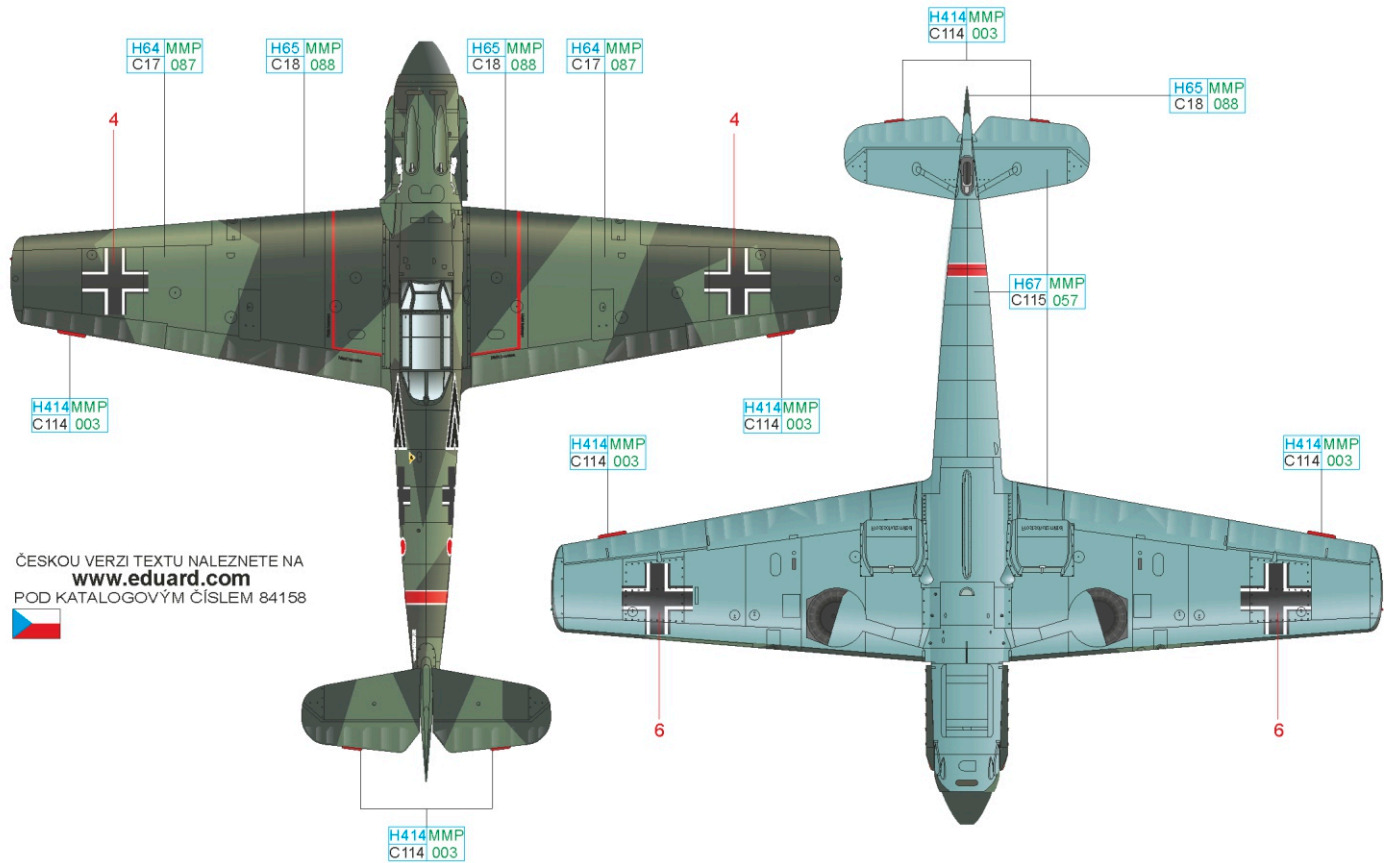
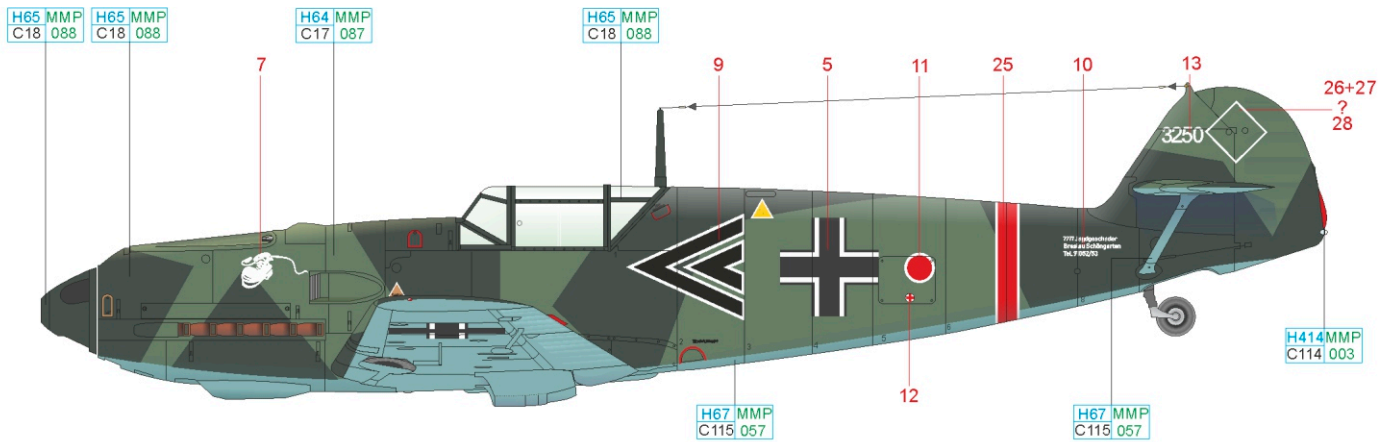

ČESKOU VERZI TEXTU NALEZNETE NA  
[www.eduard.com](http://www.eduard.com)  
 POD KATALOGOVÝM ČÍSLEM 84158

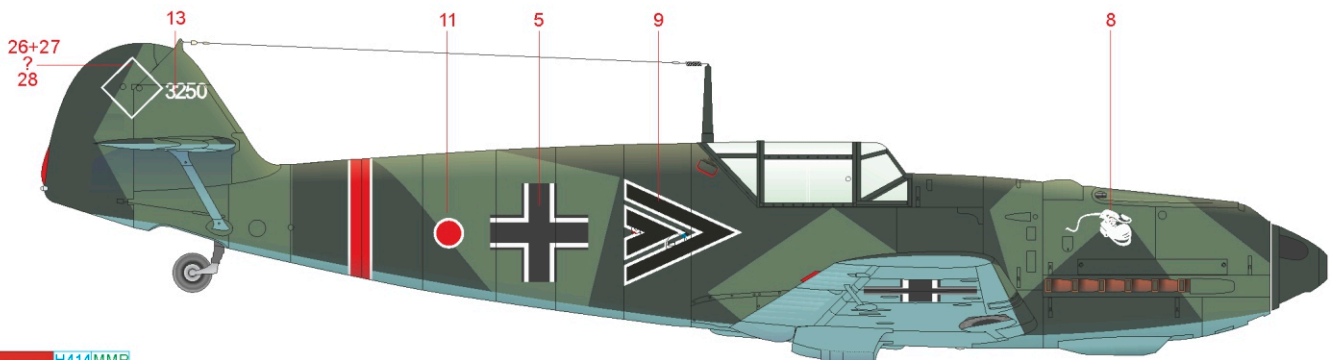

RLM 23	H414 MMP C114 003	RLM 71	H64 MMP C17 087	RLM 65	H67 MMP C115 057
RLM 70	H65 MMP C18 088				



