

Exhaust covers for Tiger I Ausf.E (Early/Late version)

Ostony rur wydechowych do Tygrysa
wczesna / późna wersja

1/16 scale update for Tamiya, Hobby Boss model

ABER® **16 007**

WWW.ABER.NET.PL

Made in Poland © 2001

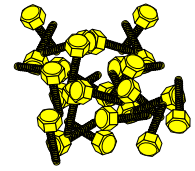
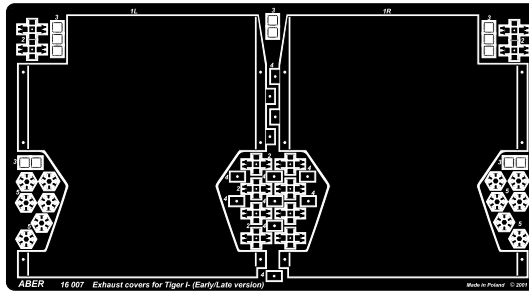

WARNING

Any unauthorized copying, producing and reproducing of ABER company products, or any part thereof, is strictly prohibited and any such action establishes liability for a civil action and may give rise to criminal prosecution.

Please note that, for purpose of improvement ABER sets designs are subjects to change without notice. Proszę mieć na uwadze fakt, że zestawy ABER mogą ulec zmianie ze względu na ulepszenia, bez powiadomienia.

Use Cyanoacryl glue (kleić klejami cyjanoakrylowymi)

We advise that better method to join metal to metal is soldering. Use ABER soldering solution AF20 (doradzamy łączenie części metalowych za pomocą lutownicy. Zastosuj nasz topnik AF20)

OSTRZEŻENIE

Jakiegokolwiek kopiowanie, produkowanie i reprodukcja wyrobów firmy ABER bez zezwolenia, w całości lub części jest surowo zabronione. Powyższe działania powodują powstanie odpowiedzialności cywilnej oraz mogą spowodować wszczęcie postępowania karnego.

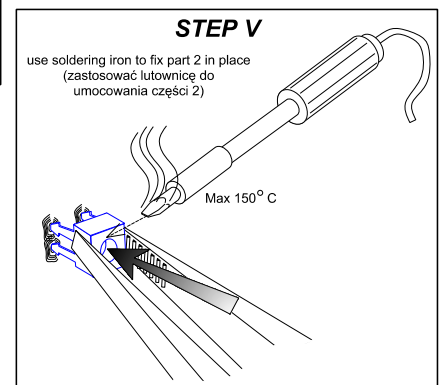
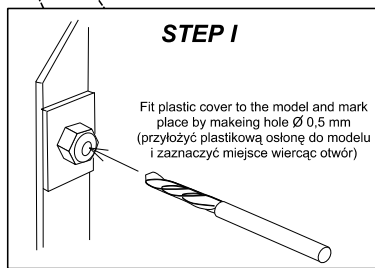
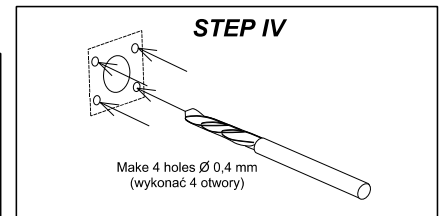
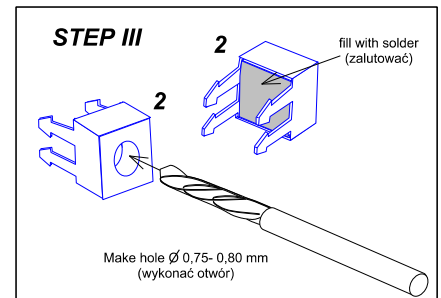
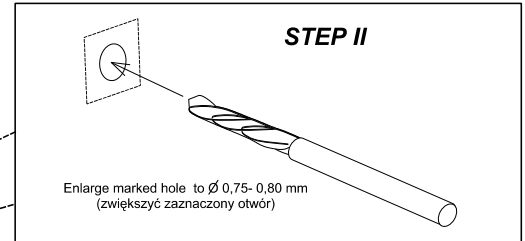
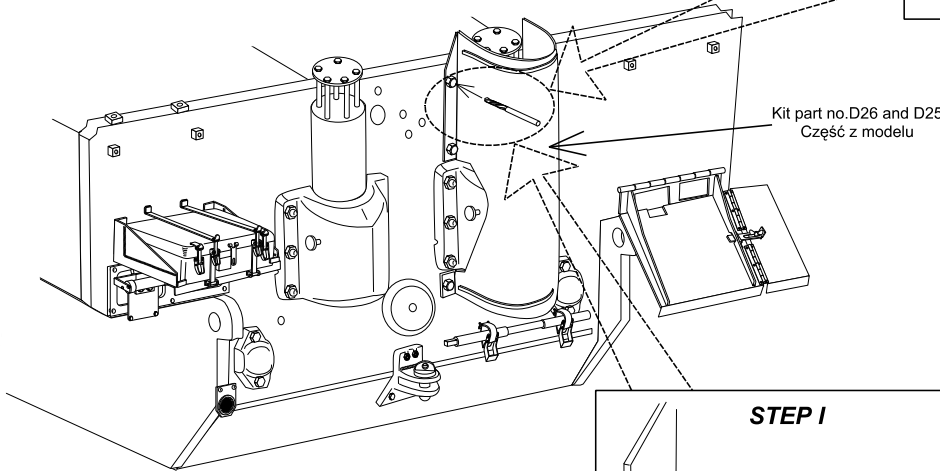

Separately sold (oddzielnie w sprzedaży):

- 16 002 -TIGER I, Ausf.E - Early vesion (Basic set)
- 16 003 -TIGER I, Ausf.E - Grilles (Early vesion)
- 16 004 -Front fenders Tiger I, Ausf.E (Early/Late vesion)
- 16 005 -Rear fenders Tiger I, Ausf.E (Early vesion)
- 16 006 -Side fenders Tiger I, Ausf.E (Early/Late vesion)
- 16 007 -Exhaust covers Tiger I, Ausf.E (Early/Late vesion)
- 16 008 -TIGER I, Ausf.E - Early vesion (Additional set)
- 16 009 -Commander's cupola interior for Tiger I, Ausf.E early vesion
- 16 010 -Driver's hatch details for Tiger I, Ausf.E (for all vesions)
- 16 012 8,8 cm Tiger I A/T Ammo with box
- 16 032 German 2 meter standard Antenna
- 16 L-03 - German barrel for tank machine gun MG 34 with Panzermantel

